

# **JWTS<sup>®</sup>** Power and free conveyor chains

The new-generation iwis power and free conveyor chains L 88SF and M 120SF combine an optimized load distribution with a more gentle and even transport of the conveyed goods. The synthetic chain guides are capable of carrying up to a double of the weight because the offset roller arrangement on which the chains run reduces the load on the guides by 50 %.

iwis power and free conveyor chains allow easy positioning of the transported material at any point along the transport path and remove the need to start and stop the chain, thereby unsettling the conveyed material. The normal chain speed is 0.1 to 0.5 m/s.

By fitting a simple acceleration rail, the conveying speed can be doubled (at locations in which material is not accumulated) without changing the chain speed. This is often used to separate goods.

Thanks to a special wax lubricant, the chains are low-maintenance. Applied only to the actual links during the assembly of the chains, the conveying rollers – and therefore the conveyed material – remain clean and have no contact with the lubricant. A special-purpose initial lubrication can be used for special-purpose applications. Conveying rollers made from hardened steel or antistatic plastic are available.





## **Iwis® Power and free conveyor chains**

### PROBLEM/INITIAL SITUATION

- Simple and reliable transport of a very wide range of workpieces and workpiece carriers
- Continuous conveying, accumulating, singling out and acceleration

### OUR SOLUTION

High performance power and free chains in accordance to the high iwis standard in a very wide range of designs.

- L 88 SF and M 120 SF, the exclusive new iwis generation of power and free conveyor chains.

### ++ EXCLUSIVE ++

- All 1/2" and 3/4" power and free conveyor chains are equipped with **"light running rollers"**.

### HIGHLIGHTS

- Gentle transportation and optimum support for the material being conveyed
- In accumulating operation, roller friction only (see figure below)
- The newly developed **"light running rollers"** lead to a high reduction of drive power.
- Please refer to diagram friction force on page 50.

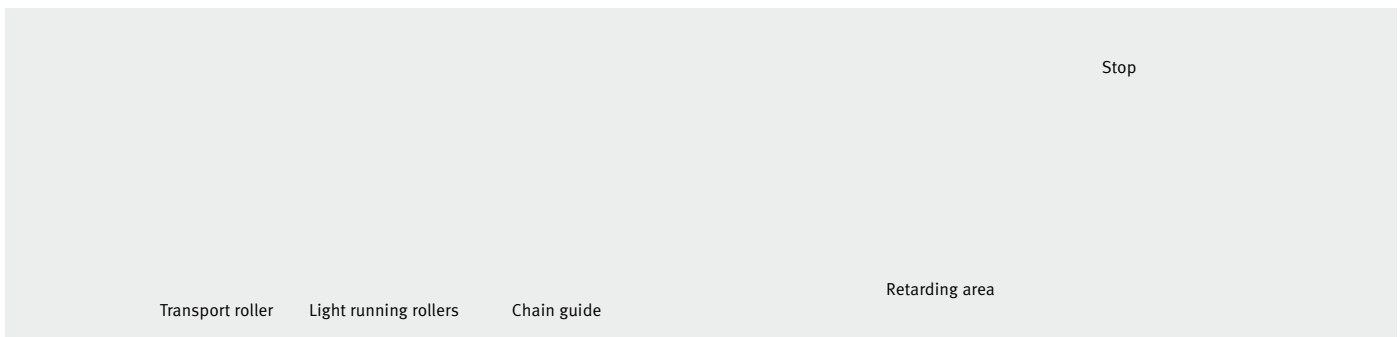

- Positioning the material transported with ease due to simple mounting points
- Chain no longer starts and stops jerkily
- Twice the transport speed is possible due to a simple acceleration rail (see figure below)
- Transport rollers made of either hardened steel or plastic (also antistatic)
- The outside of the chain is clean because only the articulated points are lubricated
- Low-maintenance due to special wax lubrication (standard)
- Other initial lubrication for special applications on request
- Fully compatible with existing guides, deflector units and chain wheels



## **Iwis® Power and free conveyor chains**

### Additional advantages

#### ADDITIONAL ADVANTAGES OF THE NEW POWER AND FREE CONVEYOR CHAINS L 88 SF AND M 120 SF

- Optimum load distribution – each pin bears load  
→ figure ① and ②
- Better support and smoother running of the conveyed material due to the transport rollers having an offset arrangement  
→ figures ③ and ④

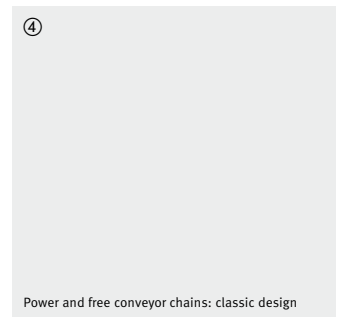
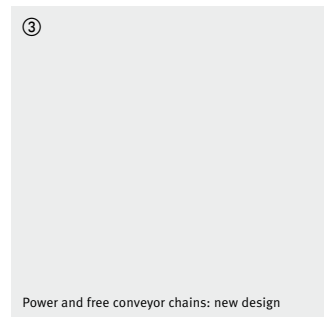
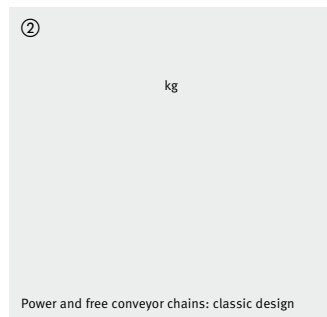
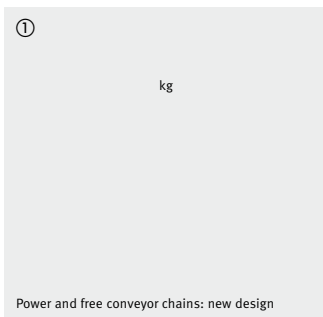

Power and free conveyor chains

### Dimensions - new power and free chains

Ref. no. iwis	Pitch p (mm)	Chain width				Diameter (mm)	Transport roller	
		B (mm)	b (mm)	b <sub>¼</sub> (mm)	e (mm)		Loading capacity per roller (kg)	Weight (kg/m)
L 88 SFK	12,70	27	9,2	14,50	18,70	16,00 <sup>1)</sup>	6	0,85
L 88 SFS	12,70	27	9,2	14,50	18,70	16,00	8	1,40
M 120 SFK	19,05	40	11,70	19,55	29,0	24,0 <sup>1)</sup> / 26,0 / 27,0 <sup>1)</sup> / 28,0	10	1,8
M 120 SFK	19,05	45	11,70	19,55	31,5	24,0 / 26,0 / 27,0 / 28,0	10	1,8
M 120 SFS	19,05	40	11,70	19,55	29,0	24,0 <sup>1)</sup> / 26,0 / 27,0 <sup>1)</sup> / 28,0	15	2,8
M 120 SFS	19,05	45	11,70	19,55	31,5	24,0 / 26,0 / 27,0 / 28,0	15	2,8



<sup>1)</sup> Supplied ex stock

SFK - with plastic transport rollers SFS - with hardened steel transport rollers

# Iwis® Power and free conveyor chains

## Side bow power and free conveyor chains

### OUR SOLUTION

L 88 SF SB and M 120 SF-SB design – **the solution** for modular changes of direction in conveyor systems

### HIGHLIGHTS

- Extremely small minimum radius for curves 300 mm L 88 SF-SB and 350 mm for M 120 SF-SB

Optimum contact between bush and pin (bearing surface) in curve area (see illustration „our solution“ below)

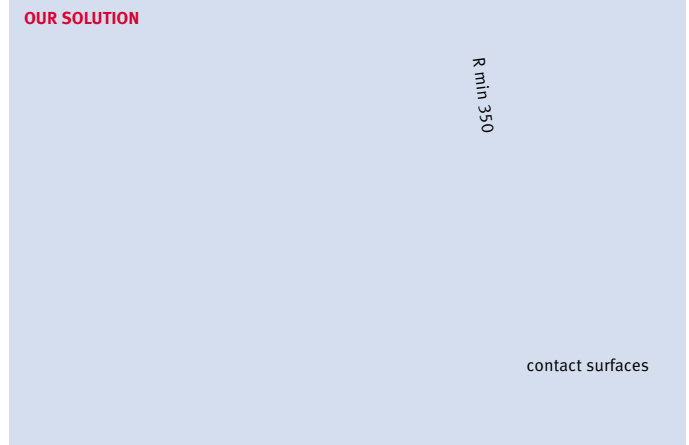
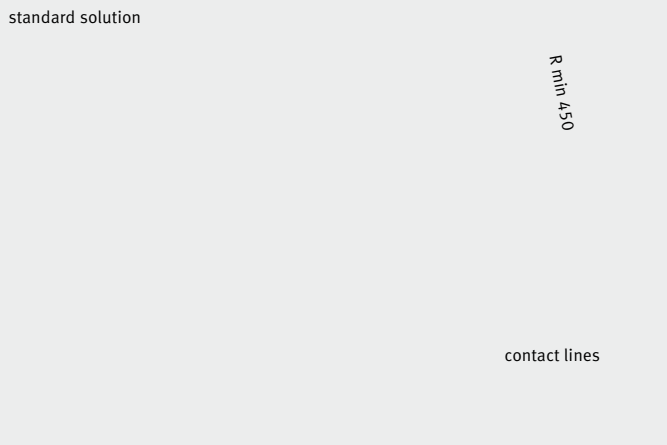

Ref. no. iwis	Pitch p (mm)	Chain width				e (mm)	Transport roller		
		B (mm)	b (mm)	b <sub>4</sub> (mm)	Diameter D (mm)		Loading capacity per roller (kg)	Weight (kg)	
L 88 SFS-SB	12,70	27	9,2	15,0	18,70	16,00	8	1,40	
M 120 SFK-SB	19,05	40	11,70	20,10	29,0	24,0 / 26,0 / 27,0 / 28,0	10	1,8	
M 120 SFS-SB	19,05	40	11,70	20,10	29,0	24,0 / 26,0 / 27,0 / 28,0	15	2,8	

Connecting link dimensions vary

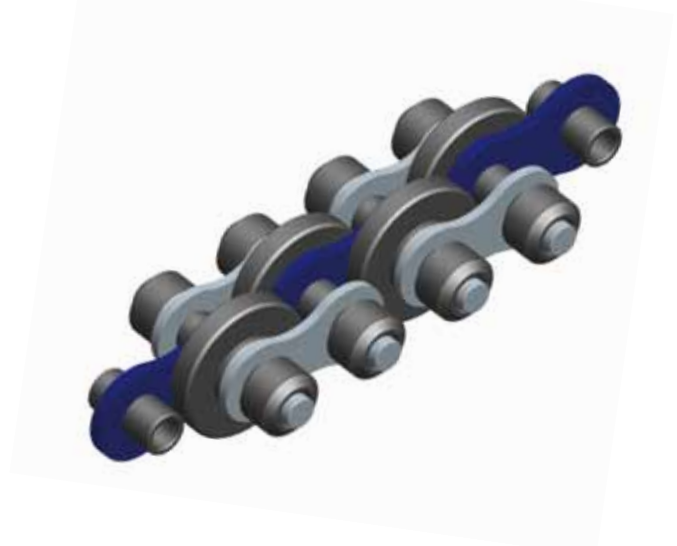

## IWIS® Power and free conveyor chains

Dimensions - classic power and free conveyor chains (also available devoid of washers)

Ref. no. iwis	Pitch p (mm)	Chain width B (mm)	e (mm)	b <sub>1</sub> (mm)	b <sub>2</sub> (mm)	b <sub>4</sub> (mm)	Width b (mm)	Transport roller			Diameter			
								Diameter	Loading capacity per roller (kg)	Roller d <sub>1</sub> (mm)	Pin d <sub>2</sub> (mm)	Weight (kg/m)		
<b>Design OS</b>														
L85 SFK	12,7	27	18,7	7,75	11,35	14,5	7,55	-	16	-	6	8,51	4,45	0,802
L85 SFS	12,7	27	18,7	7,75	11,35	14,5	7,55	-	16	-	8	8,51	4,45	1,223
M 127 SFK	19,05	40	27,5	11,75	15,62	19,55	11,0	24,0	26,0	28,0	10	12,07	5,72	1,550
M 127 SFS	19,05	40	27,5	11,75	15,62	19,55	11,0	24,0	26,0	28,0	-	12,07	5,72	2,592
<b>Design M</b>														
M 127 SFK	19,05	40	27,5	11,75	15,62	19,55	11,0	24,0	26,0	28,0	10	12,07	5,72	1,742
M 127 SFK	19,05	43	29,0	11,75	15,62	19,55	11,0	24,0	26,0 <sup>1)</sup>	28,0	10	12,07	5,72	1,646
M 127 SFK	19,05	48	31,5	11,75	15,62	19,55	11,0	24,0	26,0	28,0	10	12,07	5,72	1,920
M 127 SFS	19,05	40	27,5	11,75	15,62	19,55	11,0	24,0	26,0	28,0	15	12,07	5,72	2,688
M 127 SFS	19,05	43	29,0	11,75	15,62	19,55	11,0	24,0	26,0	28,0	15	12,07	5,72	2,688
M 127 SFS	19,05	48	31,5	11,75	15,62	19,55	11,0	24,0 <sup>1)</sup>	26,0	28,0	15	12,07	5,72	2,880
M 1611 SFK <sup>2)</sup>	25,4	65	44,9	17,02	25,45	32,0	16,5	38,5	-	-	25	15,88	8,28	4,104
M 1611 SFS <sup>2)</sup>	25,4	65	44,9	17,02	25,45	32,0	16,5	38,5	-	-	30	15,88	8,28	6,552
D 1611 SFS	25,4	99	76,9	17,02	25,45	63,4	16,5	38,5	-	-	30	15,88	8,28	11,584
<b>Design LR</b>														
LR 165 SFK <sup>2)</sup>	25,4	30,7	20,0	7,75	11,30	14,65	7,5	24,0	-	-	6	8,52	4,45	0,792
LR 247 SFK	38,1	48	31,5	11,75	15,62	19,55	11,0	24,0	35	-	10	12,07	5,72	1,200
LR 247 SFS	38,1	48	31,5	11,75	15,62	19,55	11,0	24,0	35	-	15	12,07	5,72	2,016
LR 3211 SFK <sup>2)</sup>	50,8	67,9	44,9	17,02	25,45	32,0	16,5	50,0	38,5	-	25	15,88	8,28	2,764
LR 3211 SFS <sup>2)</sup>	50,8	67,9	44,9	17,02	25,45	32,0	16,5	50,0	38,5	-	30	15,88	8,28	5,236

<sup>1)</sup> Supplied ex stock <sup>2)</sup> Chains without light running rollers  
 SFK - with plastic conveyor rollers SFS - with hardened steel conveyor rollers

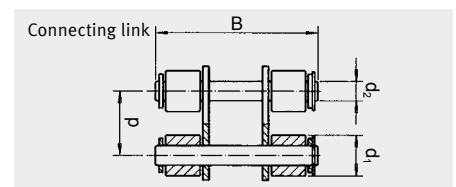

Design OS devoid of washers

Design M normal pitch

Design LR double pitch

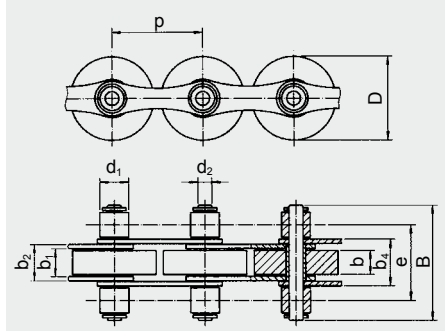
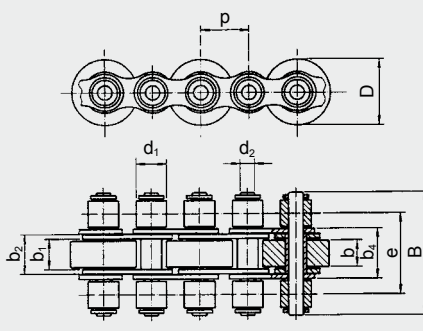

## **iwis® MEGAlife SFK & SFS – maintenance free iwis power & free conveyor chains**

### PROBLEM/INITIAL SITUATION

- Lubrication is not at all or only partly possible
- Clean & dry surroundings required
- Difficult/obstructed lubrication passage
- Contamination of installation and material to be conveyed due to chain lubrication

### OUR SOLUTION

Maintenance power and free conveyor chain with special redesigned joint and transport rollers made of sintered metal – a technical innovation – **the first genuine maintenance free power and free conveyor chains with light running rollers.**

### HIGHLIGHTS

- Excellent wear resistance – also under extreme environmental conditions
- Easy to dismantle
- Reduced overall maintenance cost
- Less production stop and machine downtime
- Environmentally-friendly due to lubrication free chain surface
- Chains suitable for clean rooms

### TECHNICAL FEATURES

- Dry chain surface and transport rollers
- Corrosion resistant
- Transport rollers optional as plastic material or steel (stainless steel or nickel-plated)
- Temperature range for use –40 °C up to +160 °C (for transport rollers made of steel)
- iwis MEGAlife power and free conveyor chains are available in the new iwis or classic design in 1/2 inch and 3/4 inch pitch
- Transport rollers made of sintered metal reduce friction. This leads to reduction of driving power and strain on the chain

### AREAS OF APPLICATION

- Electronic Industry & Circuit Board Manufacture
- Packaging & Food Industry
- Conveyor-Equipment
- Wood, Glass & Ceramic Industry
- Medical Technology

... and of course in all areas where relubrication is not at all or only partly possible.

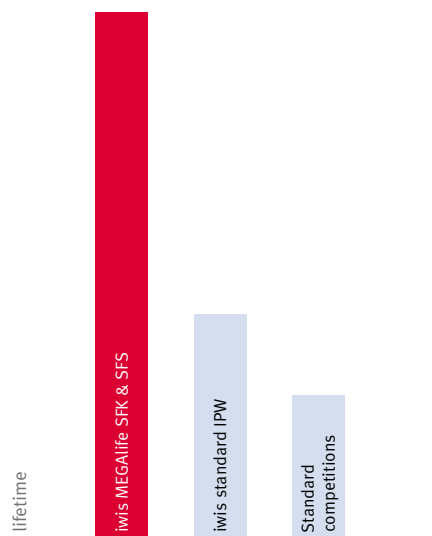

Comparison: lifetime operating time of power and free conveyor chains – without relubrication

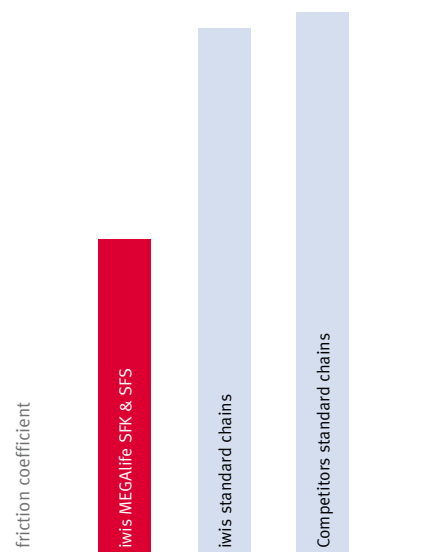

Comparison: coefficient of friction

## IWIS® MEGAlife SFK & SFS

### Dimensions - new power and free conveyor chains

Ref. no. iwis	Pitch p (mm)	Chain width				Transport Roller			
		B (mm)	b (mm)	b <sub>¼</sub> (mm)	e (mm)	Diameter (mm)	Loading capacity per roller (kg)	Weight (kg/m)	
L 88 SFK-ML	12,70	27	9,2	14,50	18,70	16,00	6	0,85	
L 88 SFS-ML	12,70	27	9,2	14,50	18,70	16,00	8	1,40	
M 120 SFK-ML	19,05	40	11,70	19,55	29,0	24,0 / 26,0 / 27,0 / 28,0	10	1,8	
M 120 SFK-ML	19,05	45	11,70	19,55	31,5	24,0 / 26,0 / 27,0 / 28,0	10	1,8	
M 120 SFS-ML	19,05	40	11,70	19,55	29,0	24,0 / 26,0 / 27,0 / 28,0	15	2,8	
M 120 SFS-ML	19,05	45	11,70	19,55	31,5	24,0 / 26,0 / 27,0 / 28,0	15	2,8	

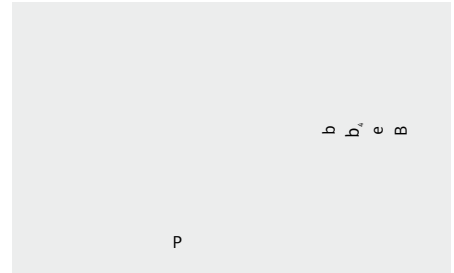

SFK – with plastic conveyor rollers SFS – with hardened steel conveyor rollers

### Dimensions - classic power and free conveyor chains

Ref. no. iwis	Pitch p (mm)	Chain width B (mm)	e (mm)	b <sub>1</sub> (mm)	b <sub>2</sub> (mm) max.	b <sub>3</sub> (mm) max.	Width b (mm)	Transport Roller			Diameter			
								Diameter	Loading capacity per roller (kg)	Roller d <sub>1</sub> (mm)	Pin d <sub>2</sub> (mm)	weight (kg/m)		
<b>Design OS</b>														
L85 SFK-ML	12,7	27	18,7	7,75	11,3	14,5	7,55	-	-	16	6	8,51	4,45	0,802
L85 SFS-ML	12,7	27	18,7	7,75	11,3	14,5	7,55	-	-	16	8	8,51	4,45	1,223
M 127 SFK-ML	19,05	40	27,5	11,75	15,62	19,55	11,0	24,0	26,0	28,0	10	12,07	5,72	2,3
M 127 SFS-ML	19,05	40	27,5	11,75	15,62	19,55	11,0	24,0	26,0	28,0	15	12,07	5,72	3,1
<b>Design M</b>														
M 127 SFK-ML	19,05	40	27,5	11,75	15,62	19,55	11,0	24,0	26,0	28,0	10	12,07	5,72	2,3
M 127 SFK-ML	19,05	43	29,0	11,75	15,62	19,55	11,0	24,0	26,0	28,0	10	12,07	5,72	2,3
M 127 SFK-ML	19,05	48	31,5	11,75	15,62	19,55	11,0	24,0	26,0	28,0	10	12,07	5,72	2,3
M 127 SFS-ML	19,05	40	27,5	11,75	15,62	19,55	11,0	24,0	26,0	28,0	15	12,07	5,72	3,1
M 127 SFS-ML	19,05	43	29,0	11,75	15,62	19,55	11,0	24,0	26,0	28,0	15	12,07	5,72	3,1
M 127 SFS-ML	19,05	48	31,5	11,75	15,62	19,55	11,0	24,0	26,0	28,0	15	12,07	5,72	3,1

Design OS devoid of washers

Design M normal pitch

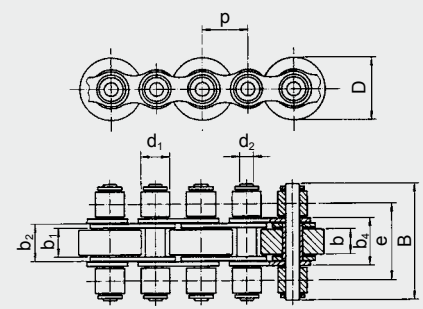

Connecting link

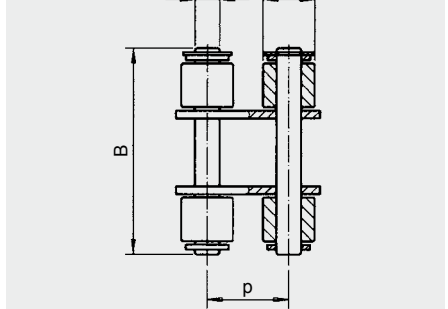



## Iwis® Power and free conveyor chains

### Accessories

#### COMPARISON FRICTION FORCE

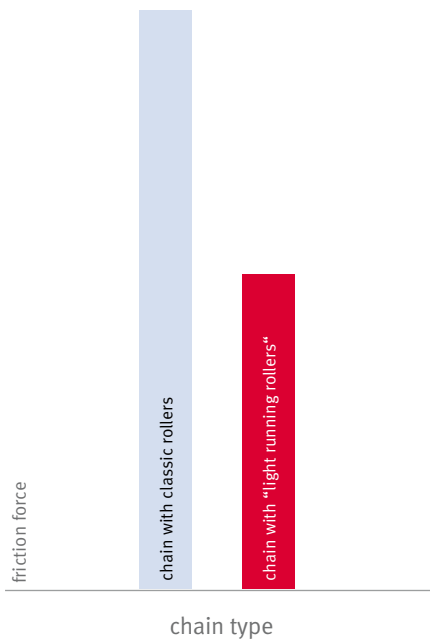

The highly reduced friction force results in a substantial reduction of drive power for the complete unit.

#### ATTACHMENTS

Guide plates and filler pieces on request.

#### CHAIN WHEELS

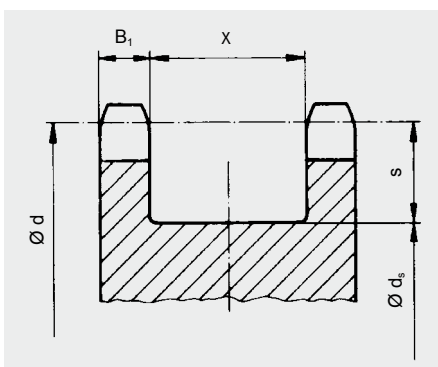

Ref. no. iwis	Pitch p (mm)	B <sub>1</sub> (mm)	X (mm)	s (mm)
L 88 SF	12,7	4	15,5	10
M 120 SF-B40	19,05	8,3	20,7	15,0
M 127 SF-B40/B43	19,05	8,3	20,7	15,0
M 120 SF-B45	19,05	10,8	20,7	15,0
M 127 SF-B48	19,05	10,8	20,7	15,0
M 1611 SF	25,4	11,6	33,3	20,5

$d_s = d - 2s$   $d = p : (\sin 180^\circ : z)$  Recommended number of teeth minimum  $z = 15$

## **Iwis® Power and free conveyor chains** Accessories

### CHAIN GUIDE/EXAMPLE

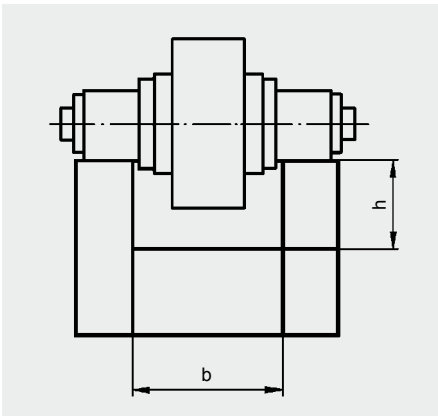

iwis chain	b (mm)	h (mm)
L 88 SF	15	10
L 88 SF SB	15,5	10
M 120 SF	20	15
M 120 SF SB	21	15
M 127 SF	20	15
M 1611 SF	33	20

### TOOL



Tool for dismantling power and free conveyor chain M 120 SF and M 127 SF with 3/4 inch pitch

### CLEANING BRUSH FOR PROFILES

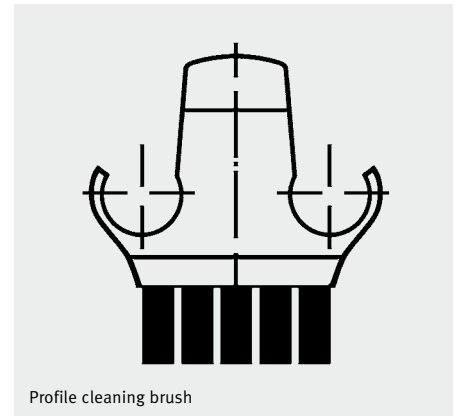

Profile cleaning brush

Multipurpose brush especially designed to clean conveying profile for most stringent conditions (for example: chips, welding drops, dust etc.). Brush only available for the new power and free conveyor chain generation of M 120 SF.

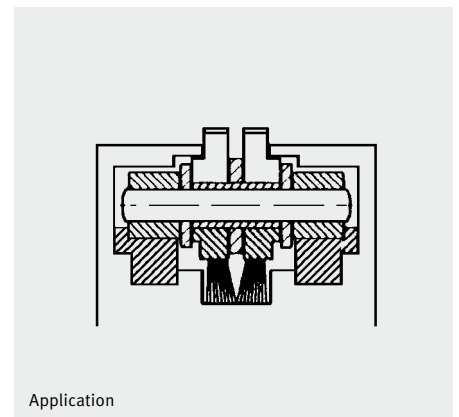

Application

## Iwis® Power and free conveyor chains

### MAINTENANCE GUIDE FOR POWER AND FREE CONVEYOR CHAINS

As for every roller chain, the „bearing points“ of the power and free chain are also subject to natural wear. The correct tension, good guidance and effective relubrication are needed to reduce this and therefore increase the service life of the chain.

A power and free conveyor chain works perfectly at up to 2% extension caused by wear with the provision that it is constantly retensioned. Approximately 5% of the actual chain tensioning force occurring can be used as a guide value for pretensioning.

Power and free conveyor chains are given extremely effective initial lubrication in the works. The lubricant is used up in the course of time and effective and regular relubrication is necessary. During this process, care must be taken that the lubrication is undertaken at the correct points (= bearing points) and that the lubricant is able to creep.

### INFORMATION ON THE DESIGN OF POWER AND FREE CONVEYOR CHAINS

Important criteria when selecting a power and free chain are:

- Loading on the transport rollers from the weight of the material being conveyed on them. The load-bearing strength per roller is stated in the tables. If the contact surface for the material being conveyed is uneven, it is necessary to estimate how many free rollers are actually load-bearing.
- Loading on the chain from tensile forces occurring in operation. The most important influencing dimensions are the weight of the material conveyed and the friction factors. The following tensile forces occur in power and free chains:
  - from friction resistance between roller and chain pin
  - from friction resistance between transport rollers and chain bush when in accumulating operation
  - from roller resistance when rolling the runners on to the chain guides and when rolling the conveyed materials on to the transport rollers.

Rough determination of the chain tensioning force  $F$  per chain strand:

$$F = \frac{\mu \cdot 9,81 \cdot Q \cdot 1,4}{n} \text{ [N]}$$

$\mu$  = friction value 0.08-0.3 depending on:

- material pairing  
Steel/steel or plastic/steel
- Condition of the friction surfaces:  
dry or lubricated
- Degree of contamination of the friction surfaces

$Q$  = Total weight conveyed [kg]  
 $n$  = Number of chain strands

The formula is valid for even distribution of the weight loading over the chain strands. If the conveyed material is not in full contact because of unevenness, an estimate has to be made as to what percentage of the length in contact is actually effective. The tensile strength per chain strand is correspondingly higher.

### MAX. CONVEYOR LENGTH

Depending on loading 25–30 m, parallel and exact guidance must be ensured.

### AREA OF USE...

... of power and free conveyor chains:

- In many areas of conveyor engineering
- Where there are links in processing and assembly lines
- In warehouse engineering
- In a wide range of material flow systems

... and everywhere where work-pieces, components for storage, pallets, containers, crates etc. have to be conveyed, accumulated, accelerated and singled out in a simple way.

### RECOMMENDED WORKING LOAD

iwis chain	Recommended max. working load [N]
L 88 SF	1500
L 85 SF	2300
M 120 SF	2500
M 127 SF	4000
M 1611 SF	5000
D 1611 SF	10000

## Notes

