

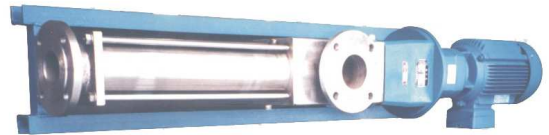

G 型



LG 型

螺杆泵的性能参数

型号	压力 (Mpa)	转速				电机功率 (KW)
		100 转/时 (升)	200 转/时 (升)	300 转/时 (升)	400 转/时 (升)	
G15-1	0.6	89	178	267	356	0.55
G25-1	0.6	356	712	1069	1424	0.75
G35-1	0.6	591	1182	1773	2364	1.5
G40-1	0.6	1059	2118	3177	4236	2.2
G50-1	0.6	2587	5174	7761	1348	4
G70-1	0.6	4733	9466	14199	18932	7.5
G85-1	0.6	8678	17356	26034	34712	11
G105-1	0.6	18100	35200	54300	70400	22
LG20	0.6	356	712	1068	1424	0.75
LG27-1	0.6	666	1332	1998	2664	1.5
LG44-1	0.6	1620	3240	4860	6480	3
LG53-1	0.6	5300	10600	15900	21200	7.5
LG60-1	0.6	7300	14600	21900	29200	11
LG80-1	0.6	15120	30240	45360	60480	22

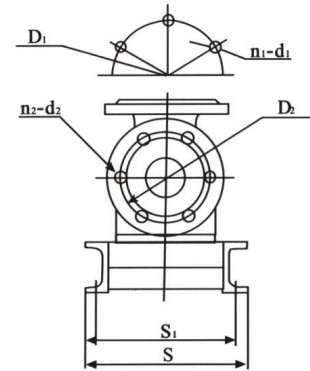
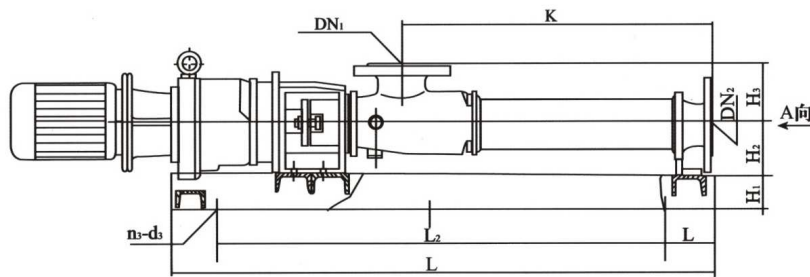

尺寸表:

型号	DN1	D1	n1-d1	DN2	D2	n2-d2	H1	H2	L	L1	L2	S	S1	n3-d3	K
G15-1	32	90	4-12	25	75	4-12	60	90	550	100	350	230	180	4-10	214
G20-1	50	110	4-13	40	98.5	4-16	60	90	856	108	640	240	185	4-12	324
G25-1	50	125	4-18	40	110	4-18	60	90	816	108	600	240	185	4-16	282
G35-1	65	145	4-18	50	125	4-18	80	100	980	115	750	260	224	4-16	367
G40-1	80	160	4-18	65	145	4-18	80	125	1425	115	1195	260	224	4-48	439
G50-1	100	215	8-18	80	160	8-18	80	140	1750	115	1520	370	338	4-48	560
G70-1	125	210	8-18	100	215	8-18	80	160	1970	60	1850	370	338	6-18	689
G85-1	150	240	8-18	125	210	8-18	80	160	2190	60	2070	386	348	6-18	754
G105-1	200	295	8-18	150	240	8-18	100	180	2536	100	2336	469	456	6-18	118
LG20-1	50	110	4-13	40	98.5	4-16	60	90	740	100	540	200	164	4-13	324
LG-27-1	50	125	4-18	40	110	4-18	60	90	840	150	540	240	204	4-16	425
LG44-1	80	160	8-18	65	150	4-18	80	100	1110	100	910	350	214	4-18	630
LG53-1	100	190	8-18	80	160	8-18	80	125	1340	60	1220	260	224	6-18	768
LG60-1	100	190	8-18	100	160	8-18	80	130	1470	60	1350	280	244	6-18	927
LG80-1	150	240	8-18	125	210	8-18	100	150	2130	60	2010	350	314	6-18	1320