



# **JWTS**<sup>®</sup> Chain guide

Regular maintenance and lubrication are preconditions for low wear and long service life of the chain drive. The maintenance and lubrication frequency, as well as the related re-lubrication, are determined by the operating conditions of the application. The iwis chain guide outlines the choice of possible chain lubrications and recommended re-lubricants. All initial lubricants are developed especially for iwis and their composition is tailored to be the best possible for the product chain. Please contact our Technical Service Team for more information regarding the maintenance and handling of chains. We will happily advise you!



## Lubricating the **iwis**® chains iwis chain lubricants

### OUR CHAIN LUBRICANTS - THE BEST POSSIBLE SOLUTION FOR EVERY APPLICATION.

Sufficient and effective lubrication increases the length of life of the chains several times over. The selection of the correct lubricant and the appropriate method of lubrication guarantee good reduction of wear, sufficient protection from corrosion and optional damping characteristics. Countless trials on specially developed test equipment and close collaboration with well known lubricant manufacturers make iwis your competent partner for all questions relating to chain lubrication.

All iwis chains are provided with sufficient, reliable, high quality initial lubrication in accordance with precisely stipulated procedures, which are the subject of constant monitoring, and delivered ready for installation. All the initial lubricants are developed especially for iwis and their composition is tailored to be the best possible for the chain product.

### A SUMMARY OF OUR INITIAL LUBRICANTS

**IP2** the proven standard lubricant with a good lubricating effect and excellent corrosion protection for applications of all kinds from -10° to +80°C.

**IP3** long-lasting lubrication at higher speeds, loads and temperatures. As a consequence of its high viscosity, it is absolutely resistant to spinning off over the entire temperature range from -5° to +150°C.

**IPW** the handling-resistant high performance lubricating wax with very high wear protection permits significantly longer intervals between applications of lubricant. Problem-free use as a „barrier grease“ in all environments where dust and powder are present. Temperature range from -10° to +80°C.

**IP4** thermally stable high temperature lubricant with good wear- and corrosion-resistance. Low evaporation rate in the temperature range from 0° to +250°C. Forms no residue at temperatures above 250°C.

**IP9** the corrosion-protection for preservative use with a very low lubricant effect. Temperature range from 0° to +70°C.

**IP14** dry lubricant for slow-running chain drives and low to medium loads. Stove enamel with built-in lubricant for applications from -70° to +250°C.

**IP16** the lubricant for food use with good wear- and corrosion-resistance. Meets the requirements of USDA-H1 and LMBG - authorised for contact with food. Temperature range from -20° to +130°C.

**IPO** low temperature lubricant with optimum lubricating effect. Able to flow in the entire temperature range from -45° to +150°C.

## Re-lubrication of the **iwis**® chains Re-lubricants

### RE-LUBRICATION

The life of a chain is dependent to a decisive extent on correct and adequate topping up of the lubricant. As a consequence of the oscillating movements of the chain link, the initial lubricant is used up in the course of time depending on the operating conditions. If the lubricant is topped up regularly, the chain is mainly within the range of fluid and mixed friction. An absence of lubricant or badly selected re-lubricants cause dry friction, which leads to the formation of fretting corrosion and increased wear of the chain.

The selection of the lubricant and the correct lubrication technique is decisive for effective re-lubrication.

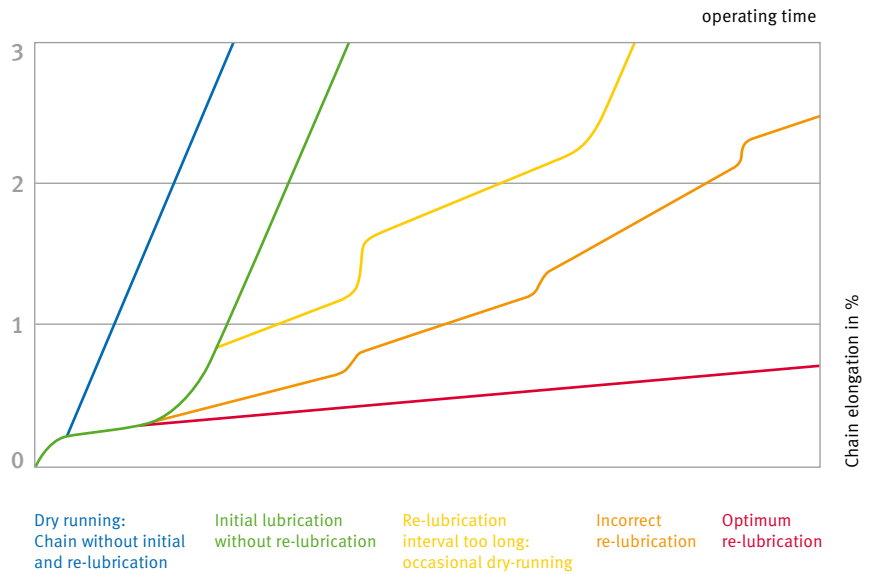

Chain guide

### RECOMMENDED RE-LUBRICANTS FOR OUR INITIAL LUBRICANTS

- IP2** iwis VP6 Kombi superplus (spray)  
All standard commercial chain oils
- IP3** iwis VP6 Kombi superplus (spray)  
High performance chain oils from various manufacturers, e.g. STRUCTOVIS HD-series from Klüber Lubrication
- IPW** iwis VP6-Kombi superplus (spray)  
High performance chain oils from various manufacturers, e.g. STRUCTOVIS HD-series from Klüber Lubrication
- IP4** iwis VP6-Kombi superplus (spray)  
High temperature chain oils from various manufacturers, for temperatures above 250°C with proportions of solid lubricant

- IP9** iwis VP6-Kombi superplus (spray)  
All conventional chain oils
- IP14** iwis VP6-Kombi superplus (spray)  
Chain oils containing a proportion of solid lubricant such as graphite, MOS2
- IP16** chain oils approved for food use, e.g. Klüberoil UH 1-series
- IPO** low temperature chain oils from various manufacturers

### RE-LUBRICANTS

should possess the following characteristics - depending on the application:

- Adhesiveness
- Compatibility with initial lubricant
- Corrosion protection
- Load-bearing capacity of lubricant film
- Ability to creep
- Lubrication of emergency running
- High viscosity and simultaneous ability to flow
- High temperature stability
- Water-repellent
- Resistance to media etc.

■ Designation initial lubricant  
 ■ Recommendation re-lubricant

## Lubricating the **IWIS**® chains

### Lubrication techniques

#### MANUAL LUBRICATION

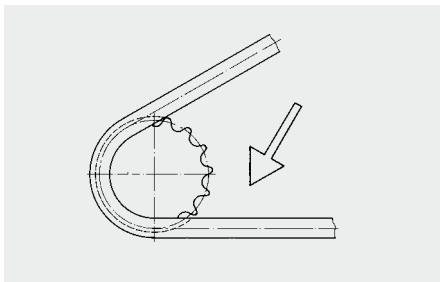

Using a paint brush, oil can or spray can for slow-running chain drives. The proven VP6-Kombi superplus (spray) is distinguished by the following characteristics:

- Synthetic high performance chain lubricant
- Optimum lubricating effect and adhesion
- Excellent ability to creep
- For normal and high temperature use up to +250°C
- Excellent corrosion protection
- Also well suited to O-seal chains

#### RECOMMENDATIONS

The chain drive should be cleaned with a brush before the lubricant is topped up to enable the lubricant to enter. In addition the surface of the chain can be cleaned with cleaner's naphtha or petroleum. Full submersion and washing out is not recommended.

Connecting elements (for example, connecting links), when supplied separately, have only been immersion-protected against rust and must be greased upon installation. If the connecting links are supplied together with the chains, they will have been greased with the same lubricant as the chains.

#### DRIP LUBRICATION

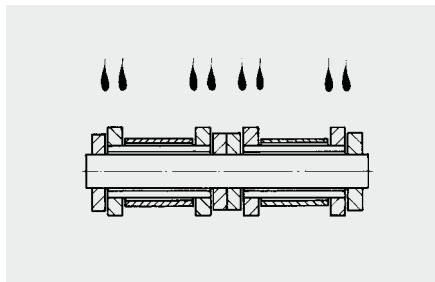

Using drip oilers, automatic lubricant feed or central lubrication units at medium chain speeds.

#### OIL BATH LUBRICATION

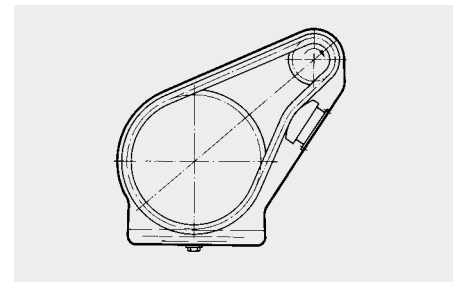

Using enclosed chain boxes and, if necessary, additional centrifugal disc for fast-running chain drives

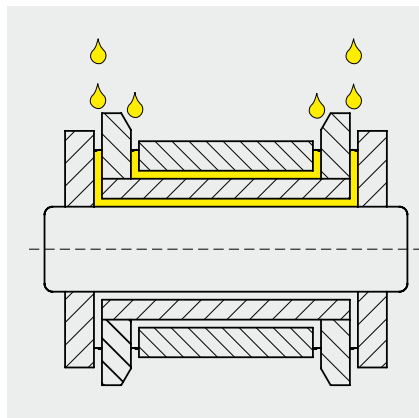

The lubricant product must be able to penetrate into the bearing area of the chain. To guarantee this the lubricant must be applied deliberately to the gap between the inner and outer plates.

## Efficient chain maintenance

Regular maintenance and lubrication are preconditions for low wear and long service life of the chain drive. Maintenance and lubrication frequency, as well as the related re-lubrication, is determined by operating conditions (tensile forces, temperature, contamination, aggressive media).

### MEASUREMENT OF STRETCHING DUE TO WEAR

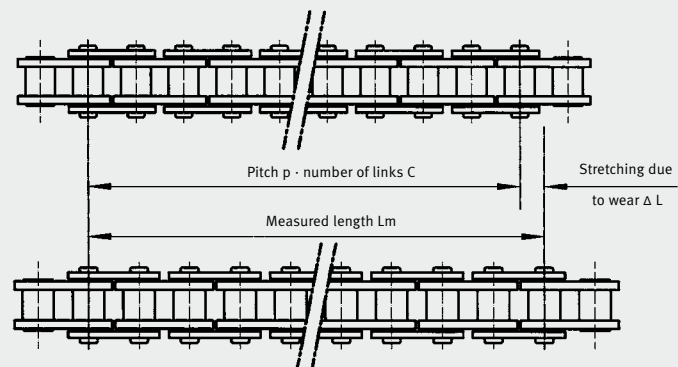

$$\Delta L = \frac{L_m - (p \cdot X)}{p \cdot X} \cdot 100 [\%]$$

### MAINTENANCE

During **regular visual inspections** special attention should be paid to **stretching due to wear, tension, lubrication condition, and evidence of wear due to tracking errors.**

#### Checking the maximum permissible stretching due to wear:

The length of a chain is defined by the pitch  $p$  and the number of links  $X$ . In the course of time stretching due to wear occurs, and usually this can be measured without removing the chain. The difference from precise measurement with a specified measurement load is slight if measurements are conducted over the highest possible number of chain links, approximately 20 to 40.

The **chain should be replaced** at:

- max. 3 % for simple drives
- max. 2 % for high-performance drives
- max. 1 % for special applications (synchronous operation, positioning)

Controlled **retensioning** of the chains has a very positive effect on the chain life. Extreme retensioning should be avoided just as much as excessive slack. A guideline figure would be a tension load of approx. 5 % of the actual chain pulling force. In the case of chains running in parallel both strands must be tensioned equally, at best by a common shaft for both sprockets. If no automatic chain tensioning device is available, the chain must be adjusted by hand by altering the distance between the sprocket shafts. A further possibility with long drives is to shorten the chain by removing individual links, provided that wear is relatively light. Various tools are available for dismantling and reassembling the chain. These tools are available for parallel pin and shouldered pin chains.

Before **re-lubrication** the chains and sprockets should be **cleaned** to remove obstinate contamination and to permit the lubricant to penetrate via the back of the plates. The surface of the chain can also be cleaned using an appropriate solvent.

Complete immersion and washing is not recommended as the cleaning agent does not evaporate completely from within the chain and thus the penetration of the fresh lubricant is obstructed.

During **visual inspection** attention should be paid to evidence of chain linkplate marking and wear due to tracking errors. These are caused by misaligned sprockets or guides or by chains which are not in parallel.

Guide for alignment deviations per 100 mm axle separation:

- 0.1 mm with fast-running drives and close axle spacing;
- 0.2 mm with slow-running drives.

The sprockets should be constantly inspected and if necessary replaced. We do not recommend that new chains are used with worn sprockets.

# Iwis® chain guideline

## Which application demands which chain type?

Chain guide

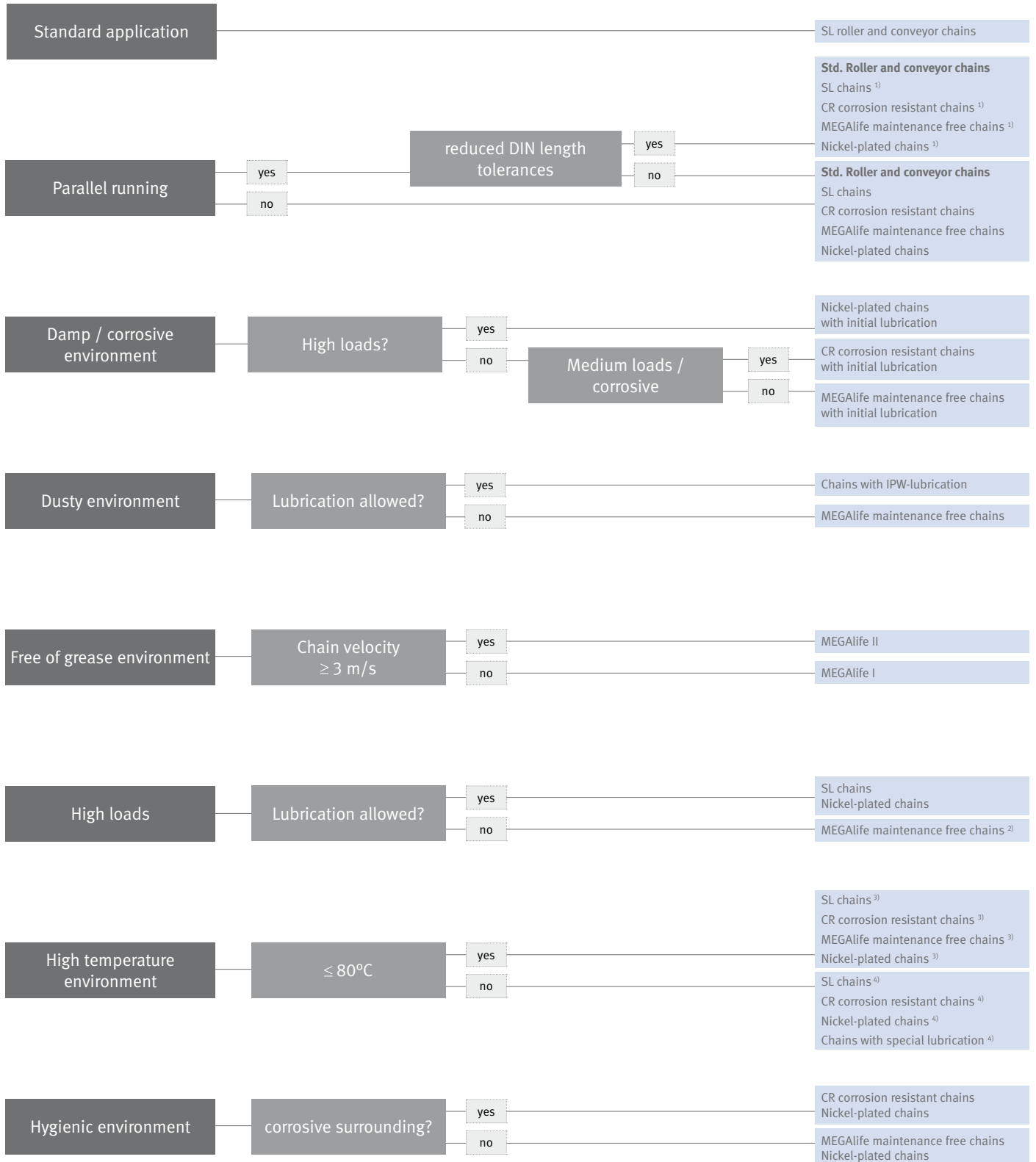

1) with reduced tolerances

2) application limited 3) with standard lubrication or IPW 4) IP up to 150°C and IP4 up to 240°C

## **iwis® chain guideline**

### Important information and notes

#### IMPORTANT DETAIL

The following guidelines support you in choosing the right chain. However, please note that each application is individual. The result should in no case serve as a basis for your order. Therefore please refer to our professional employees who are happy to submit an individual order to you. We do not assume any guarantee or liability.

#### CHAIN ENGINEERING PROGRAM

iwis provides you with a special PC-Software serving as support for the specification of the individual chain drive design or rather the preselection of the appropriate chain. Please ask our Customer Service Team!

#### FOR MORE INFORMATION TO

- SL chains  
→ Page **12** and **18**
- Nickel-plated chains  
→ Page **12**
- MEGAlife maintenance free chains  
→ Page **30**
- CR corrosion resistant chains  
→ Page **40**

#### CHAIN FABRICATION LENGTHS

- 5 m
- 10 m
- 10 Fuß

Adjusted lengths can either be supplied open or closed. Special lengths (e.g. on coils) are available on request and depending on chain type.

#### OUR CONVEYOR CHAINS

If a parallel run is necessary, iwis can manufacture and supply chain strands with precisely harmonised lengths, bundled together and marked accordingly. This is in particular important for chains with opposite cam or angle side plates.

#### PRICE SUPPLEMENTS:

Price supplements will be calculated for:

- adjusted lengths
- special lubrications
- reduced tolerances
- short lengths
- special coatings
- nickel-plated chains and single parts  
Prices on enquiry.

#### CUSTOM-MADE CHAINS

Special chains made according to customer drawings are possible. Prices on enquiry. Minimum order quantity is 50 m.

#### MINIMUM ORDER QUANTITIES FOR CONNECTORS AND CRANKED LINKS

Chain dimensions	Inner link / Outer link / Connecting link	Cottered Link
6 mm – 3/4"	20 ea	10 ea
1" – 1 1/4"	10 ea	10 ea
Duplex – Triplex	5 ea	5 ea
Parts over 1 1/4"	1 ea	1 ea



## IWIS® Questionnaire for chain drives

Enquiry from: \_\_\_\_\_ Date: \_\_\_\_\_  
 Address: \_\_\_\_\_ Dealt with by: \_\_\_\_\_  
 Telephone: \_\_\_\_\_

### DRIVE (INPUT)

Electric, hydraulic, pneumatic combustion engines/motors (2, 4 or 6 cyls)?  
 Power output? kW  
 RPM? min<sup>-1</sup>  
 Max. torque? at n = min<sup>-1</sup> Nm  
 Continuous power or peak power?  
 Speed constant, varying or impulsive?  
 Operating time, cyclic operation?  
 Are shock absorbing transmission-elements present (friction clutch)?

### OUTPUT

Type of driven machine?  
 RPM? min<sup>-1</sup>  
 Power requirement? for starting - normal running - max. kW  
 Load even, varying or impulsive?  
 Direction of rotation continuous or alternating? (show in diagram)

### CHAIN DRIVE

Centre distance mm  
 Does the design allow the centre distance to be modified? ±  
 Possibility to provide tensioner? (adjustability, idler, chain guide)  
 Could the centre distance alter in service? e.g. rear wheel suspension on a motorcycle  
 Required or current ratio respectively?  
 Shafts horizontal or vertical?  
 Can the drive be protected against dirt and dust or can it be enclosed?  
 What type of lubrication is possible? (manual, drip, oil bath, pressure)  
 External factors? (temperature in °C, dust, moisture, fibres)

### CHAIN

Chains planned or existing drive?  
 Is the chain replacing an existing drive?  
 Max. permissible chain width? mm

### CHAIN WHEELS

No. of teeth? z<sub>1</sub> = z<sub>2</sub> =  
 Max. permissible outside diameter, incl. chain? mm  
 Chain wheel as a disc or with hub, predrilled or with finished bore?



# Our subsidiaries

## Germany

iwis antriebssysteme GmbH & Co. KG  
Albert-Roßhaupter-Straße 53  
81369 München  
Tel. +49 89 76909-1500  
Fax +49 89 76909-1198  
sales@iwis.com

## Germany

iwis antriebssysteme GmbH  
Essener Straße 23  
57234 Wilnsdorf  
Tel. +49 2739 86-0  
Fax +49 2739 86-22  
sales-wilnsdorf@iwis.com

## Germany

iwis agrisystems  
Schützenweg 5  
36205 Sontra  
Tel. +49 5653 9778-0  
Fax +49 5653 9778-26  
agrisystems@iwis.com

## UK

iwis drive systems Ltd.  
Unit 8c Bloomfield Park  
Bloomfield Road, Tipton  
West Midlands, DY4 9AP  
Tel. +44 12 15213600  
Fax +44 12 15200822  
salesuk@iwis.com

## France

iwis systèmes de transmission  
10, rue du Luxembourg  
69330 Meyzieu  
Tel. +33 4374515-70  
Fax +33 4374515-71  
salesfr@iwis.com

## Switzerland

iwis AG Kettentechnik  
Bahnweg 4 (Postfach)  
5504 Othmarsingen  
Tel. +41 62 8898999  
Fax +41 62 8898990  
info@iwis-ketten.ch

## Italy

iwis antriebssysteme Italia  
Tel. +39 340 9296142  
Fax +49 89 76909 491647  
salesit@iwis.com

## China

iwis drive systems Co. Ltd.  
Lu Yuan Industrial Park Nanhui  
Building NO. 8, Liuzhao Town  
No. 369 Luji Road, 201322 Shanghai  
Tel. +86 21 338964-21  
Fax +86 21 338964-20  
sales@iwis.com

## USA

iwis drive systems, LLC  
Building 100, 8266 Zionsville Road  
Indianapolis, IN 46268 USA  
Tel. +1 317 821-3539  
Fax +1 317 821-3569  
sales@iwisusa.com

## Canada

iwis drive systems, Inc.  
#1- 19349- 94th ave  
Surrey B.C. V4E 4E6  
Tel. +1 778-298-3622  
Fax +1 778-298-7219  
salesca@iwisusa.com

## Brazil

iwis Sistemas de Transmissão  
de Energia Mecânica Ltda.  
R. Bento Rosa, 776  
Bairro Hidráulica  
95.900-000 Lajeado, RS  
salesbrazil@iwis.com

## South Africa

iwis drive systems (Pty) Ltd  
unit 3, 127 Koornhof Road  
Meadowdale 1614  
Phone(011) 392- 2306/7  
Fax (011) 392-3295  
salessa@iwis.com

## Turkey

iwis antriebssysteme GmbH & Co. KG  
Türkiye Istanbul İrtibat Bürosu  
Kozyatağı Mah. Bayar Cad. Gülbahar Sok. No: 17  
Perdem Sac Plaza Kat: 5 Daire: 57-58  
34742 Kadıköy-İstanbul  
Tel. +90 216 545 25 97  
Faks +90 216 545 25 98  
salestr@iwis.com

[www.iwis.com](http://www.iwis.com)

**iwis**  
antriebssysteme  
wir bewegen die welt

Your sales representative

