

## CUSTOM ENGINEERED SOLUTIONS

This catalog contains over 100,000 possible combinations of joystick products suitable for many applications. We also offer full design services to help produce a joystick product to your unique specifications.

Whether your requirements call for a custom design or a joystick modified for your application, our technical staff will work with you to fit a device to your particular needs. Customization features offered: cables, connectors, unique packaging, pushbutton switches, proportional thumbwheels, rocker switches, proximity sensors, custom colors, special marking, and custom handles.

Contact the factory for assistance.



# Contents

## FINGER OPERATED JOYSTICKS



### POTENTIOMETER JOYSTICKS

		Print	Web
M Series	Miniature resistive joysticks	5	7
4000 Series	Industrial resistive joysticks	10	12



### HALL EFFECT JOYSTICKS

HF Series	Hall effect joysticks	17	19
3000 Series	Premium Hall effect joysticks	27	29
HT series	Ruggedized Hall effect joysticks	36	38
BF Series	Paddle controllers	50	52



### SWITCHING JOYSTICKS

1000 Series	Compact switch joysticks	57	59
8000 Series	Ruggedized switch joysticks	63	65



### DESKTOP JOYSTICKS

IPD Launch	USB desktop controllers	70	72
IP Desktop	Professional USB desktop controllers	73	75
IPD Ultima	Premium USB desktop controllers	76	78
VM Desktop	USB multifunction controller	79	81



### THUMB CONTROLS

TS Series	Proportional Hall effect thumbsticks	82	84
TW Series	Hall effect thumbwheels	88	90



### INDUCTIVE JOYSTICKS

9000 Series	Inductive sensing joysticks	92	94
-------------	-----------------------------	----	----

# Contents

## HAND OPERATED JOYSTICKS



### MULTI-AXES HALL EFFECT JOYSTICKS

		Print	Web
MS Series	Mid-size Hall effect joysticks	99	101
HG Series	Hand grip Hall effect joysticks	113	115
FG Series	Fixed grip hand controllers	128	130



### SINGLE AXIS THROTTLE JOYSTICKS

TH Series	Single axis throttle joysticks	135	137
-----------	--------------------------------	-----	-----





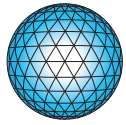

# APEM

## M series

Miniature resistive joysticks



The M Series miniature joystick is a low profile potentiometric controller providing precision multi-axes finger-positioning control. Available with up to three axes and two pushbuttons, the M Series joystick is ideal for applications requiring a compact low operating force controller. Featuring 17 ergonomically designed handles, typical applications include CCTV, robotics, electric wheelchairs, and measurement systems. The M Series is the de facto standard industrial joystick for the CCTV professional.



### KEY FEATURES

- World's #1 selling joystick for CCTV applications
- Potentiometric sensing
- One, two or three axes
- Low profile design with 17 handle options





# M series

## Miniature resistive joysticks

### OPTION SELECTION



**SERIES**

**MOUNTING BEZEL**  
**C** Split Bezel  
**F** Square Bezel  
**L** Rubber Boot Kit

**MODEL**

<b>1</b>	2 Axes
<b>2</b>	2 Axes with Pushbuttons
<b>3</b>	3 Axes
<b>4</b>	3 Axes with Pushbuttons

**CENTERING**

<b>0</b>	Spring Centering
<b>6</b>	Torque Set (Friction)

**HANDLE**

<b>0</b>	Tapered Convex
<b>1</b>	Concave Tip
<b>2</b>	Flat Tipped
<b>3</b>	Concave Tip - Long
<b>5</b>	Pushbutton
<b>6</b>	Straight Tip - Short
<b>8</b>	3 Axes
<b>9</b>	3 Axes with Pushbutton
<b>A</b>	Straight Tip - Mid
<b>B</b>	Straight Tip - Long
<b>C</b>	Ball Tip
<b>E</b>	Pushbutton
<b>G</b>	Pushbutton
<b>H</b>	Pushbutton
<b>M</b>	3 Axes No Button
<b>N</b>	3 Axes with 1 Button
<b>Q</b>	3 Axes with 2 Buttons

**OUTPUT OPTIONS**

Potentiometers<sup>3</sup> :

<b>P</b>	5KΩ, 220°
<b>M</b>	5KΩ, 56°
<b>R</b>	5KΩ, 50°

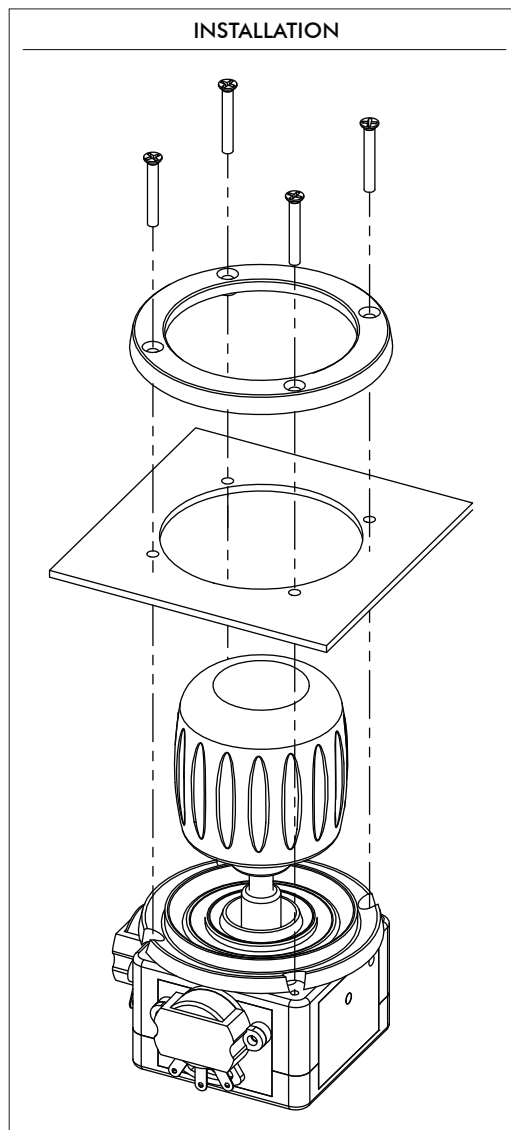

**NOTES**

1. Front Mounting Bezels (FM)

**C = Split Bezel**  
 Cutout dimensions = 39.70mm(1.562in)

**L = Rubber Boot**  
 Cutout dimensions = 39.70mm(1.1.562in)

2. Rear mounting bezels (RM)

**F = Square Bezel**  
 Cutout dimensions = 30.15mm(1.187in)

3. Potentiometer specifications are located on the next page.



Mounting accessories. Standard hardware includes:

- C = Ring, cup, and 4 black screws 2-56x1/2in
- L = Ring and 4 black screws 2-56x1/2in
- F = Square bezel, 4 screws 2-56x1/2in, and 4 screws 2-56x1/4in

# M series

## Miniature resistive joysticks

### SPECIFICATIONS

MECHANICAL (FOR X AND Y AXES)		
Break Out Force	-	0.7N (0.16lbf)
Operating Force	-	1.3N (0.29lbf)
Maximum Applied Force	-	100N (22.48lbf)
Mechanical Angle of Movement	-	56°
Expected Life	-	See potentiometer options
Mass/weight	-	Varies
Package Size (mm) (L x W x H) or (Dia x H)	-	Varies
Lever Action (Centering)	-	Spring or Friction

MECHANICAL (FOR Z AXIS)		
Break Out Torque	-	0.022N·m (0.19lbf·in)
Operating Torque	-	0.040N·m (0.35lbf·in)
Maximum Allowable Torque	-	0.049N·m (0.43lbf·in)
Mechanical Angle	-	90°
Handle Action	-	Spring

ENVIRONMENTAL		
Operating Temperature	-	-25°C to 70°C (-13°F to 158°F)
Storage Temperature	-	-40°C to 70°C (-40°F to 158°F)

POTENTIOMETER OPTIONS			
Potentiometer	P	M	R
Electrical Element	Conductive Plastic	Conductive Plastic	Conductive Plastic
Track Resistance	5K	5K	5K
Linearity	±1.0%	±5.0%	±1.0%
Track Operating Angle	220°	56°	50°
CRV	±1.5%	±1.5%	±1.0%
Power Dissipation	0.25W @ 40°C	0.5W @ 70°C	1W
Rotational Life	1,000,000	1,000,000	10,000,000

CENTERING OPTIONS	
<ul style="list-style-type: none"> <li>• <b>SPRING CENTERING</b> The joystick returns to center when the handle is released.</li> <li>• <b>TORQUE SET</b> Torque set provides absolute positioning with uniform friction applied to "X" and "Y" axes.</li> </ul>	

**NOTES:**

- All values are nominal
- Specifications are subject to the joystick configuration. Contact Technical Support for the performance of your specific configuration
- The M Series is intended for internal applications



# M series

## Miniature resistive joysticks

### DIMENSIONAL DRAWINGS

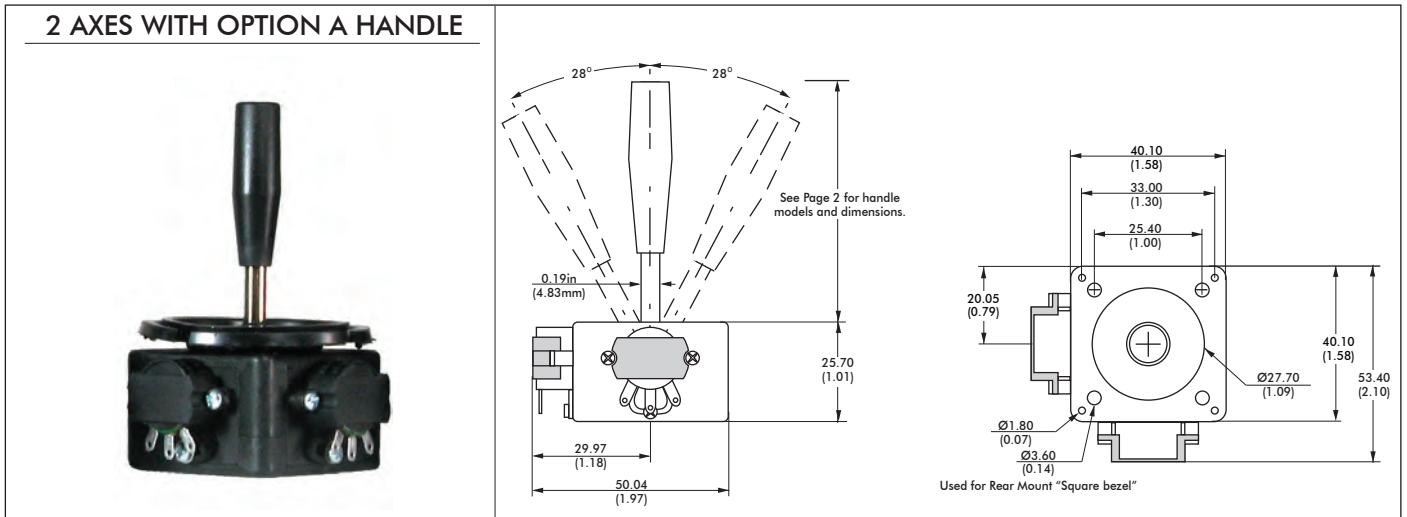

**NOTES:**

- Mechanical dimensions represent a joystick with the largest potentiometer option.
- Potentiometer size will vary according to selected option.

### HANDLES

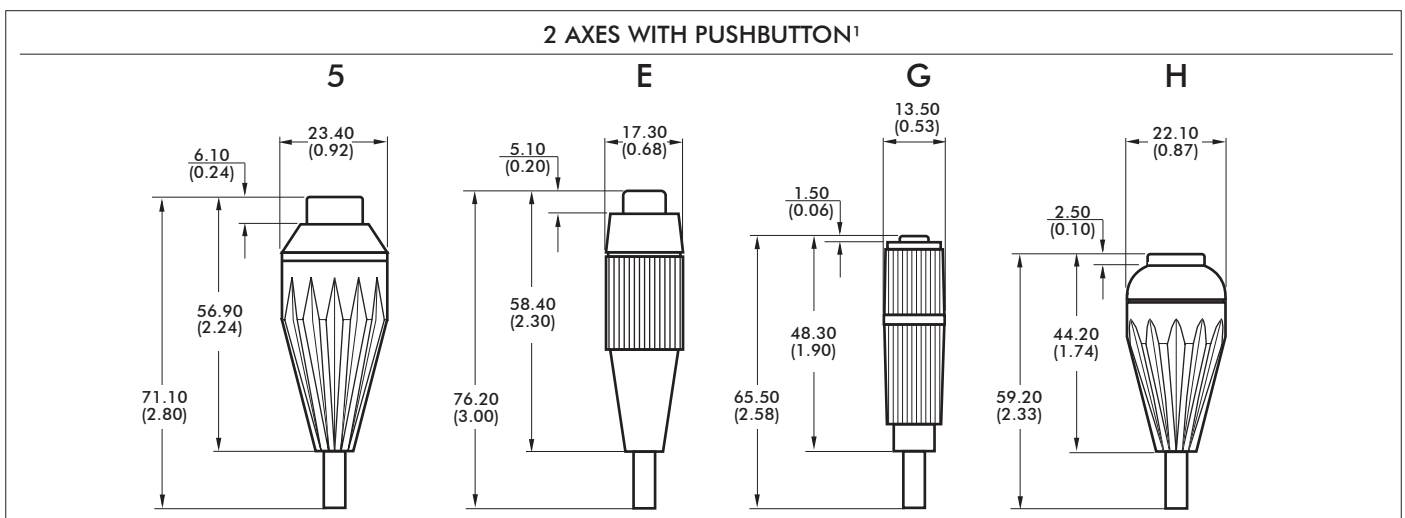
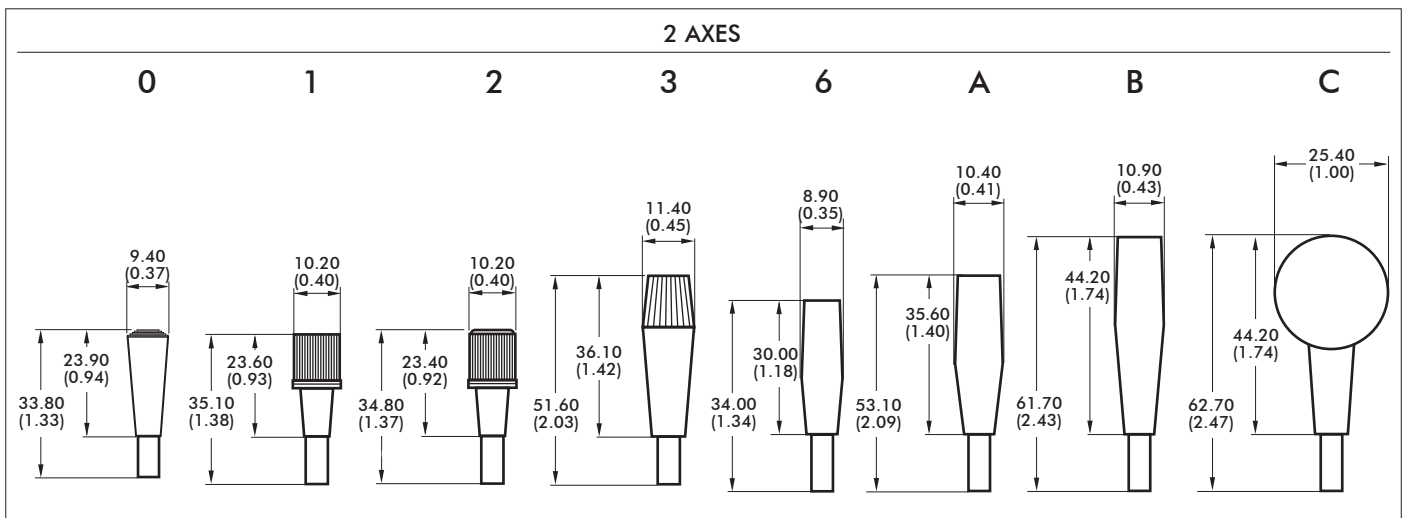

**NOTES:**

- Pushbuttons are not sealed. Joysticks are intended for internal applications only.

# M series

## Miniature resistive joysticks

### DIMENSIONAL DRAWINGS - continued

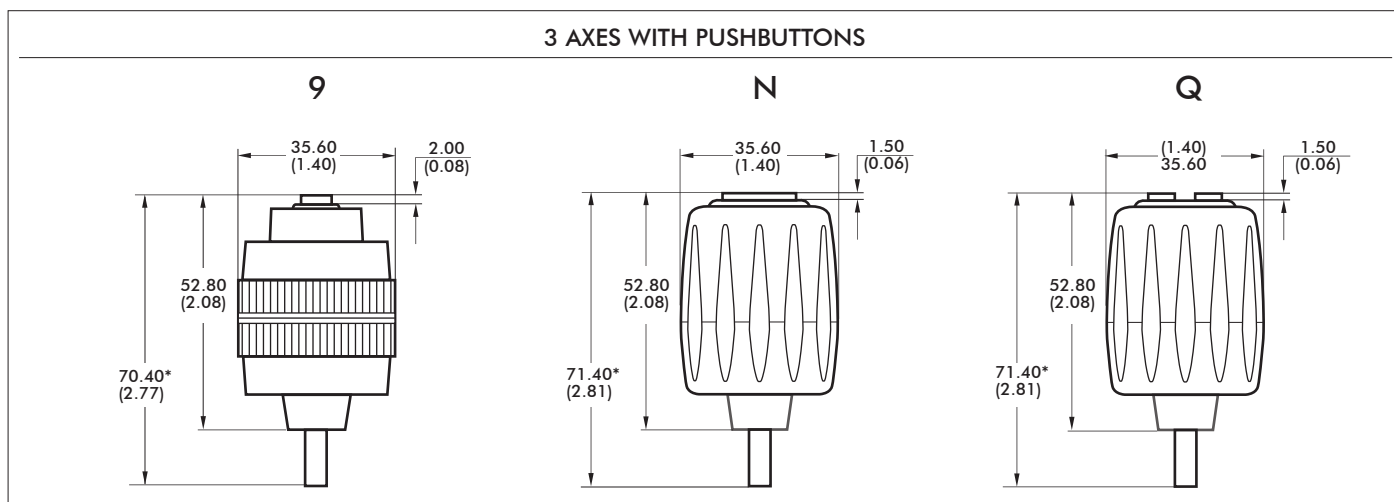
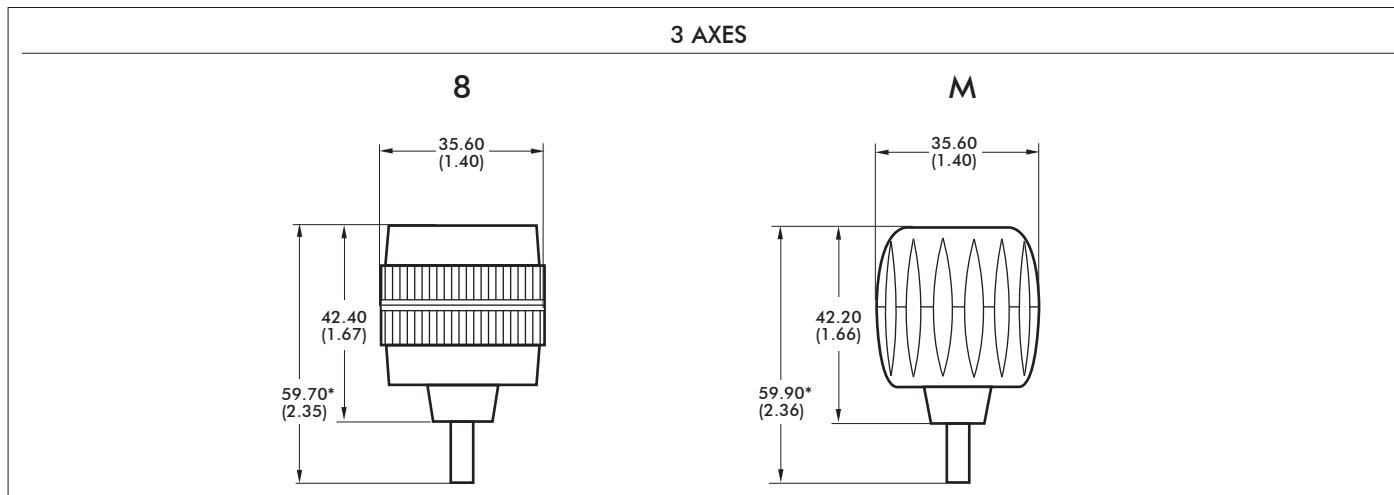

**NOTES:**

1. Dimensions are in mm/(inch)
2. Pushbuttons are not sealed. Joysticks are intended for internal applications only.

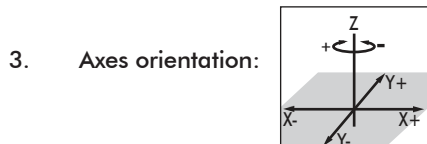

4. Wiring information: -Cables are provided for pushbuttons and the Z axis.  
-Cables are not supplied for the potentiometers (axes X and Y).

DEFAULT WIRE COLOR CODE*		
COLOR	FUNCTION	AWG
<b>2 OR 3 AXES JOYSTICK WITH 1 PUSHBUTTON - OPTIONS 5,E,G,H,9,N</b>		
ORANGE	Switch 1	28
ORANGE	Switch Common	
<b>3 AXES JOYSTICK WITH 2 PUSHBUTTONS - Option Q**</b>		
ORANGE	Switch 1	28
BROWN	Switch 2	
GREEN	Switch Common	
<b>Z AXIS IN A 3 AXES JOYSTICK - OPTIONS 8,9,M,N,Q</b>		
RED	Supply	28
WHITE	Signal	
BLUE	Return	

**NOTES:**

- \* Wires for the Z axis and for the pushbuttons are 292mm (11.5in) and stripped.
- \*\* Handle "Q" pushbuttons are shown in the following drawing:

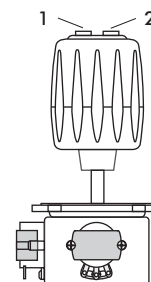



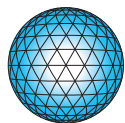

# APEM

## 4000 series

### Industrial resistive joysticks



The 4000 Series is a range of robust, industrial quality potentiometer joysticks for internal and external applications. All 4000 Series share the same, all metal mechanism to provide the finest performance and service life over a wide range of temperatures and loads. All 4000 Series employ high quality plastic film potentiometers, yielding a service life of many millions of cycles.



#### KEY FEATURES

- Two standard mounting options
- Low current drain
- Variety of potentiometer options
- Robust
- All metal mechanism
- IP65 above panel
- Inherently immune to RFI
- Optional centre-detect micro-switching
- Available in two body variants

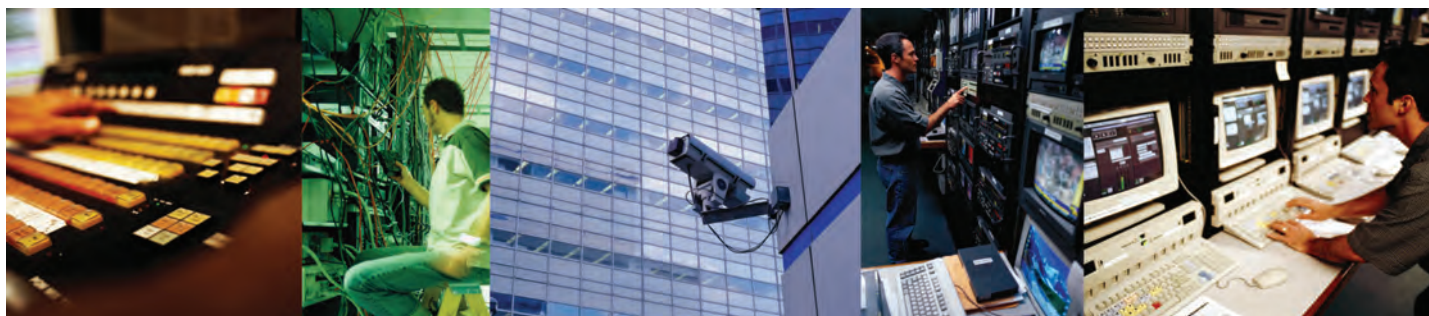

# 4000 series

## Industrial resistive joysticks

### OPTION SELECTION

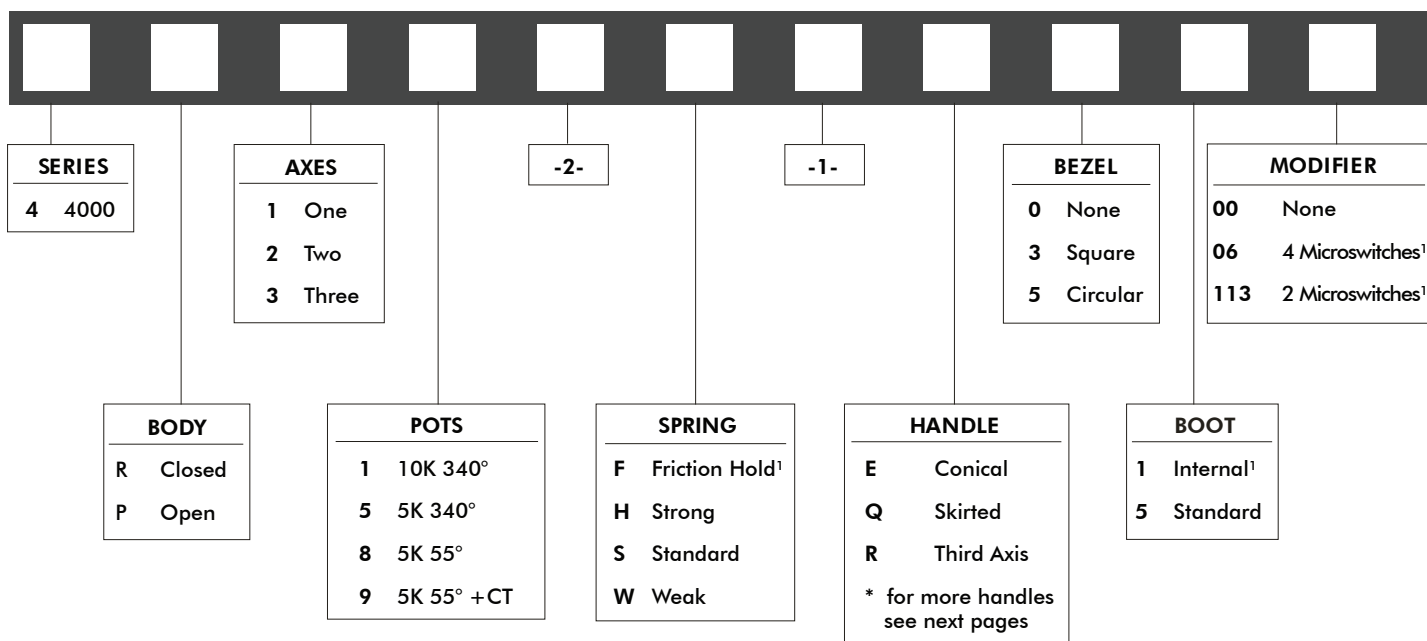

**Note:**

1 Only available on 4P types

### CABLE SPECIFICATIONS

14/0.12 - Fourteen strands of 0.12mm diameter tinned annealed copper wire PVC insulated, to a nominal OD of 1mm	
Red : +Vcc for X & Y Axes	Black : 0V for X & Y Axes
Blue : X Axis Wiper	Yellow : Y Axis Wiper
Green : Center Tap	
7/0.127 - Seven strands of 0.127mm diameter tinned copper wire ETFE insulated, to a nominal OD of 0.7mm	
Orange : Pushbutton	
Red : +Vcc for Z Axis	Blue : 0V for Z Axis
Green : Z Axis Wiper	
All 4000 Series are supplied with 150mm of twisted cable harness, with tinned ends.	
Connectors fitted upon request.	
If supplied, microswitches are rated for up to 5A and are not wired, allowing the user flexibility of connection.	

### TECHNICAL SPECIFICATION

Life Cycles : >5 Million Operations	Lever Travel : +/-27.50 Degrees
Lever Material : Stainless Steel	Body Material : Glass Filled ABS or Steel
Handle Material : See guide	Boot Material : Neoprene or Santoprene
Pivot Blocks : HE30 Alloy	Other Materials : Brass
Temperature Range : -20°C to +55°C	Resistance Tolerance : +/-20%
Linearity : +/-2%	Output Smoothness : 0.1% max
Power Rating : 1W at 70°C - Derate to 0W at 125°C	Insulation Resistance : 1000MOhms, 500VDC
Preferred Load : >100K	Potentiometer Alignment : To Center of Track (+/-1%)
Weight : 110 Grams	Above Panel Seal : IP65 (subject to handle)

**NOTES:**

- All values are nominal
- All specifications shown are based on a standard configuration and are provided for guidance only.
- Please refer to Apem for assistance on how to achieve the best performance from your chosen configuration.



# 4000 series

## Industrial resistive joysticks

### DIMENSIONAL DRAWINGS - HANDLES

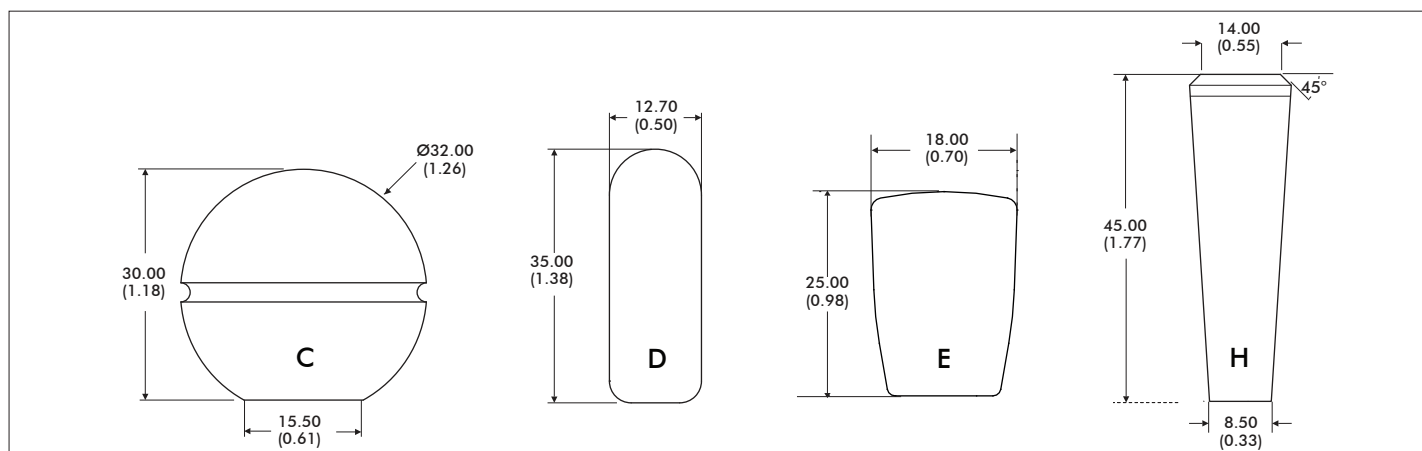

MATERIAL	Phenolic	Aluminium	Nylon	Stainless Steel
FINISH	Gloss	Anodised	Sparked Matt	Natural
STANDARD COLOR	Black	Black	Black	Stainless Steel
OTHER COLORS	Not Available	Not Available	Upon Request	Not Available
NOTES:				

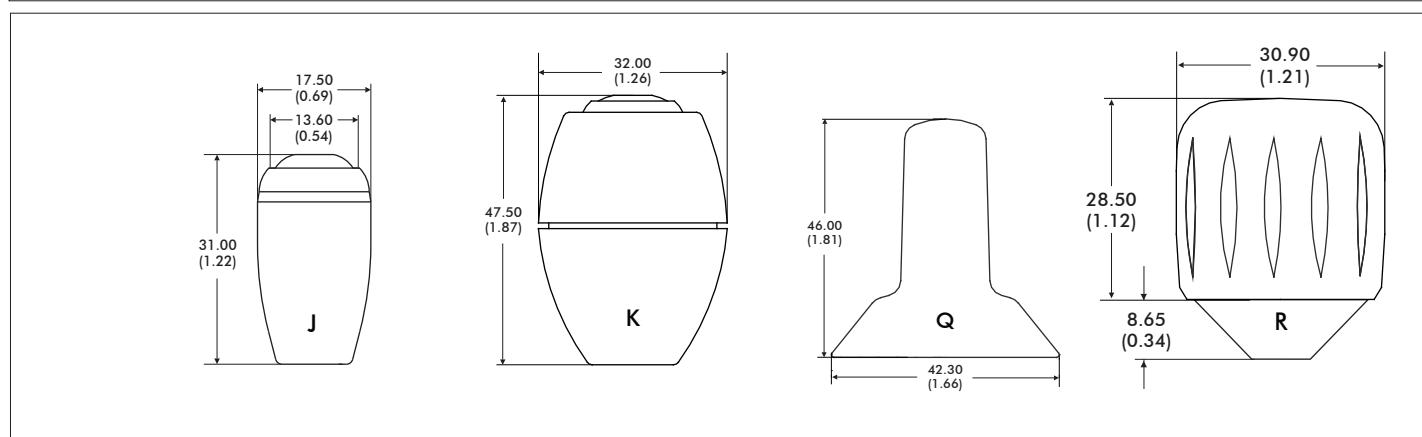

MATERIAL	ABS	ABS	Nylon	Aluminium
FINISH	Sparked Matt	Sparked Matt	Sparked Matt	Anodised
STANDARD COLOR	Black	Black	Black	Black
OTHER COLORS	Upon Request	Not Available	Not Available	Not Available
NOTES:	Uses APEM IS Switch	Uses APEM IS Switch		Third Axis function

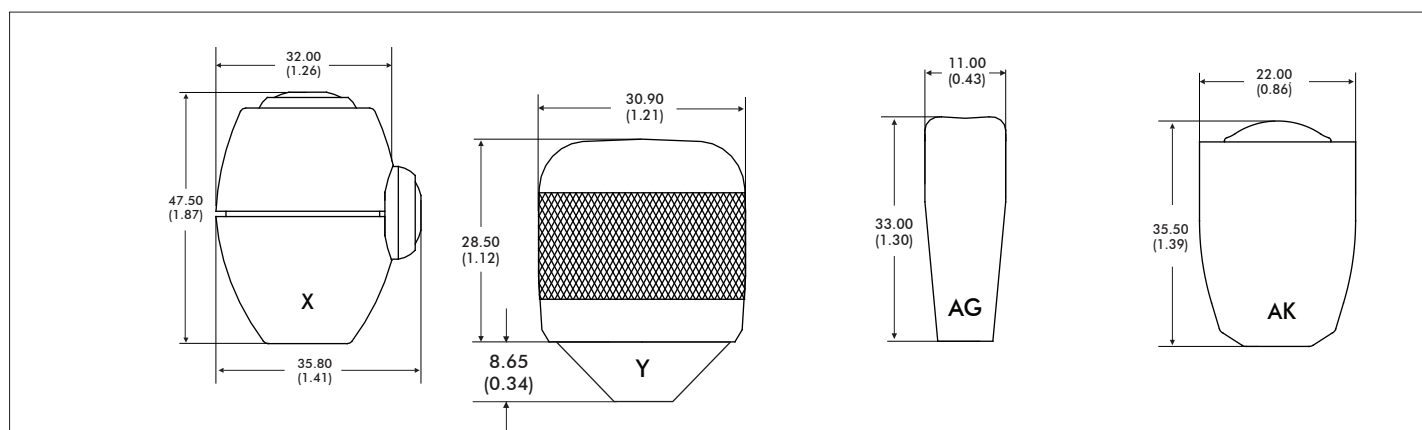

MATERIAL	ABS	Aluminium	Stainless Steel	Aluminium
FINISH	Sparked Matt	Anodised	Polished	Anodised
STANDARD COLOR	Black	Black	Stainless	Black
OTHER COLORS	Upon Request	Not Available	Not Available	Not Available
NOTES:	Uses APEM IS Switches	Third Axis function		Uses APEM IA Switch

1. Dimensions are in mm/(inch)

# 4000 series

## Industrial resistive joysticks

### DIMENSIONAL DRAWINGS - HANDLES - continued

<p><b>MATERIAL</b> Aluminium <b>FINISH</b> Anodised <b>STANDARD COLOR</b> Black <b>OTHER COLORS</b> Upon Request <b>NOTES:</b> Uses APEM IA switch</p>	<p><b>Delrin</b> <b>Gloss</b> <b>Black</b> <b>Not Available</b> <b>Uses APEM IS switch</b></p>	<p><b>Aluminium</b> <b>Anodised</b> <b>Black</b> <b>Not Available</b></p>	<p><b>Aluminium</b> <b>Anodised</b> <b>Black</b> <b>Not Available</b> <b>Uses Apem IA Switch</b></p>

<p><b>MATERIAL</b> Nylon <b>FINISH</b> Sparked Matt <b>STANDARD COLOR</b> Black <b>OTHER COLORS</b> Upon Request <b>NOTES:</b></p>	<p><b>Stainless Steel</b> <b>Polished</b> <b>Stainless Steel</b> <b>Not Available</b></p>	<p><b>Santoprene over Nylon</b> <b>Soft Touch</b> <b>Black</b> <b>Upon Request</b> <b>Z Axis functionality</b></p>

1. Dimensions are in mm/(inch)

# 4000 series

## Industrial resistive joysticks

### DIMENSIONAL DRAWINGS - continued

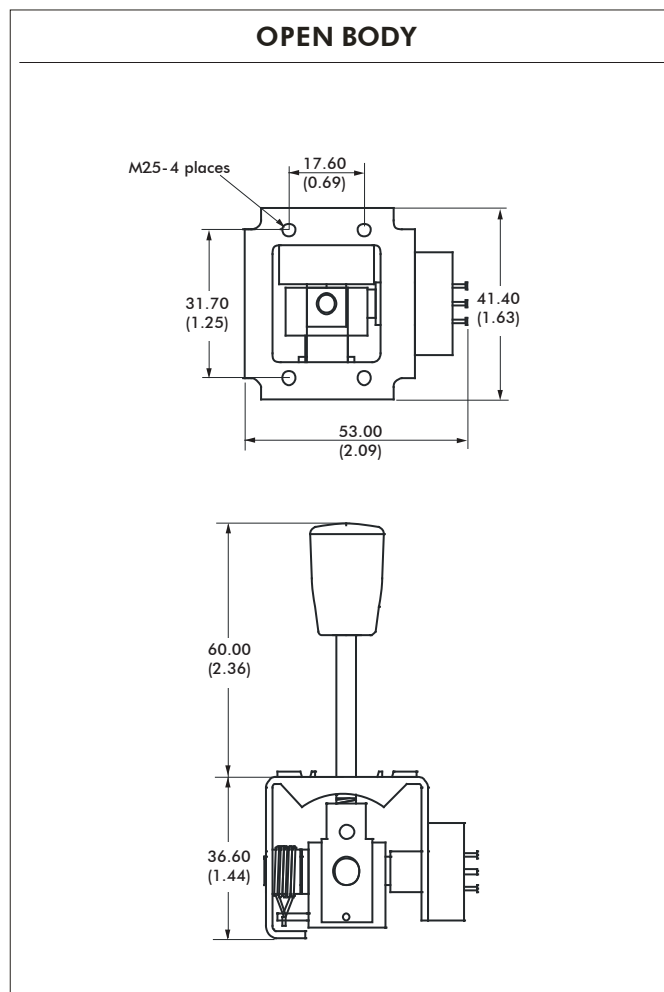
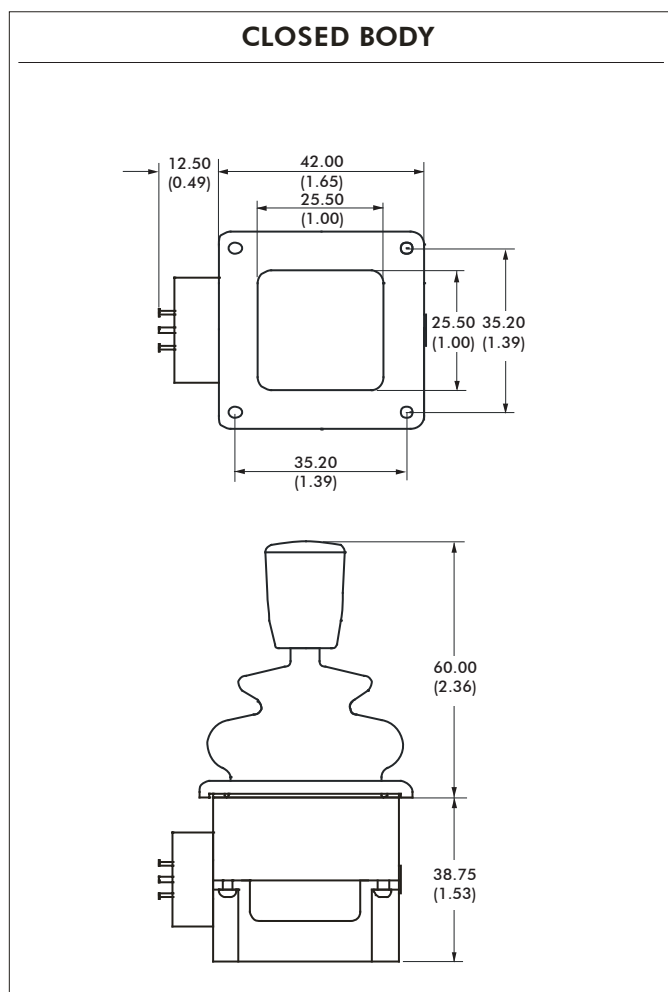

**NOTE:** The dimensions shown are for a generic two axes 4000 Series open body with the E type handle, and a generic two axes 4000 Series closed body also with the two axes E type handle. For specific dimensions of this or any other configuration please refer to Apem.

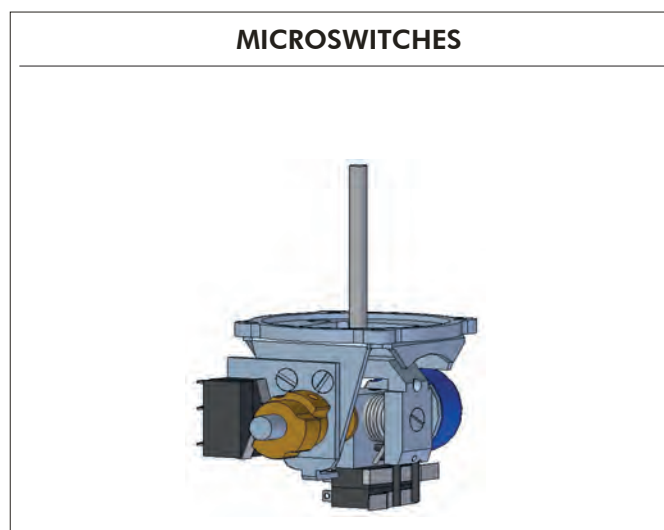
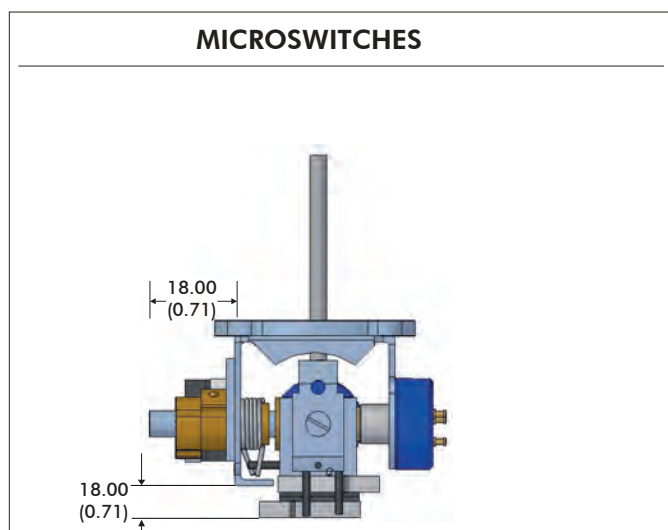

**NOTE:**

1. Dimensions are in mm/(inch)

# 4000 series

## Industrial resistive joysticks

### MOUNTING INSTALLATION

#### OPEN FRAME - PANEL CUT-OUT AND MOUNTING INSTALLATION

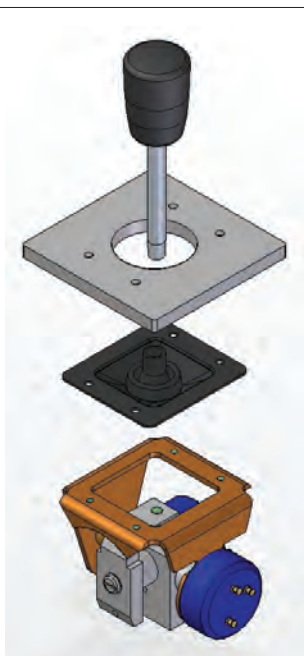

#### MOUNTING CUT-OUT

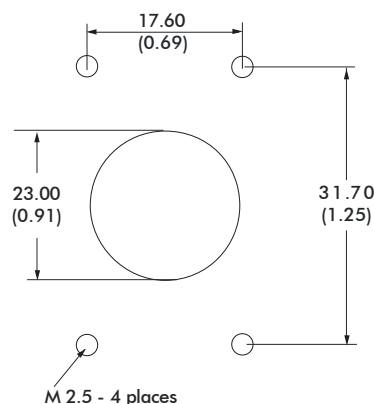

The joystick mounts from beneath the panel and the boot is trapped between the joystick and the panel. No bezel is necessary for this installation, since the panel acts as the bezel. The frame has M2.5 tapped holes and as such M2.5 machine screws are recommended for this mounting.

#### CLOSED FRAME - PANEL CUT-OUT AND MOUNTING INSTALLATION

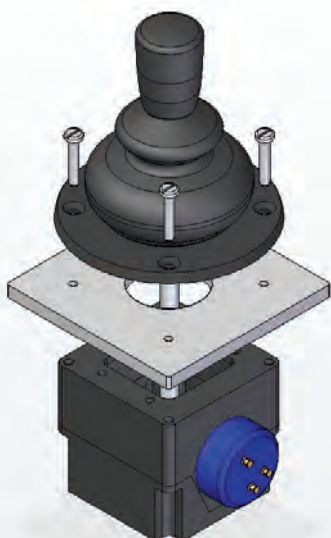

#### MOUNTING CUT-OUT

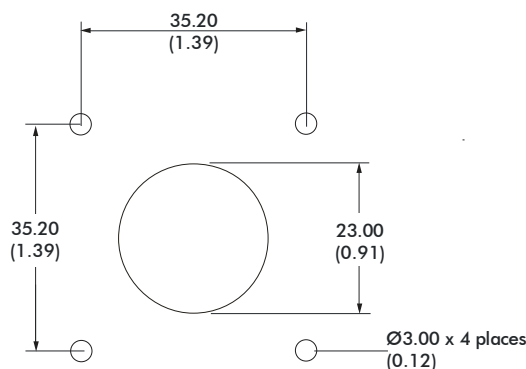

The body of the joystick is mounted from beneath the panel. The boot is passed through the panel cut-out and is held onto the front face of the panel by the mounting bezel. The square bezel has a gloss finish and is designed for use with No.4 x 3/8" pan head self tapping screws whereas the circular bezel has a matt finish and is designed for countersunk screws.

NOTES: Dimensions are in mm/(inch)

During the mounting process, great care should be taken not to damage the boot. All panel cut-outs should be free from sharp edges and swarf that may damage the boot.



# 4000 series

Industrial resistive joysticks

CONFIGURATION OPTIONS

## MECHANISM

Unlike most other products in its class the 4000 Series employs an all-metal mechanism, providing the finest feel. It delivers consistent return to center performance over life, across a broad range of applications and operating environments. The 4000 Series is offered in two body styles; the more standard closed body type should be selected for those applications requiring standard single or dual axes functionality. The open frame variant may be specified for those applications requiring friction hold functionality, additional centre detect microswitches or where the above the panel height must be kept to a minimum. Both body styles employ the same mechanism and therefore provide the same performance and feel.

## POTENTIOMETERS

The high quality plastic film potentiometers employed as standard in the 4000 Series have 340° tracks. With a shaft deflection angle of 55° (+/-27.5°), a typical 12V supply would therefore result in a full-scale nominal deflection from 5V to 7V, operating about a nominal 6V center. The 4000 Series is available with alternative potentiometers, including the option of the 5K-55° track variant, providing rail-to-rail signal swings for applications where these are necessary and additional amplification is not practical. The potentiometers on the 4000 Series are designed for use as a variable potential divider rather than a two pin variable resistor. Noise generated by the contact resistance of the wiper to the track dictates that for optimum performance the output signals should be fed into a load of greater than 100K. Potentiometer option 9 is to special order only, and may be subject to longer than standard lead times.

## PANEL CUTOUT

Being a sub-panel mount joystick the panel cut-out may be used to limit the deflection of the joystick. The maximum allowable panel cutout dimensions are shown on the following page. Where some handles may be larger than the specified panel cut-out please refer to the Apem sales team. Subsequently the joystick may be supplied without the handle fitted, or with an additional mounting plate.

## SPRINGING

As standard 4000 Series are offered sprung to center. The standard spring force requires 1.3N (nominally) to off-center the joystick. The 4000 Series may be specified with a lighter spring (1N), or a stronger spring (1.6N). N.B. Forces quoted are subject to exact joystick configuration and are provided as a guide only. The 4000 Series also offers a friction hold configuration, whereby the handle will remain in the position it is left when no operator is present. The amount of friction may be varied prior to installation by adjusting the torque setting of the friction clutches.

## SEALING

As standard, the 4000 Series is sealed to IP65 above the panel. This may be subject to exact configuration selected. Some configurations will yield an IP67 seal. Please refer to Apem for details of your chosen mounting, handle and boot options and for guidance as to the best level of panel seal achievable.

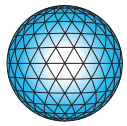

# APEM

## HF series

Hall effect joysticks



The HF joystick is a contactless, multi-axes controller providing long life finger positioning control. Featuring non-contact Hall effect technology while utilizing minimal mounting depth, the HF joystick is designed for applications requiring enduring accuracy and precision. Available with several ergonomic handles and in single, dual or triple axes configurations, ideal applications include CCTV control, robotics, medical devices, and audio video production consoles.



### KEY FEATURES

- Connectorized housing
- High voltage, 24V supply option
- Shallow mounting depth < 1.00"
- USB 1.1 HID interface option
- 1, 2 and 3 axes configurations



# HF series

Hall effect joysticks

OPTION SELECTION

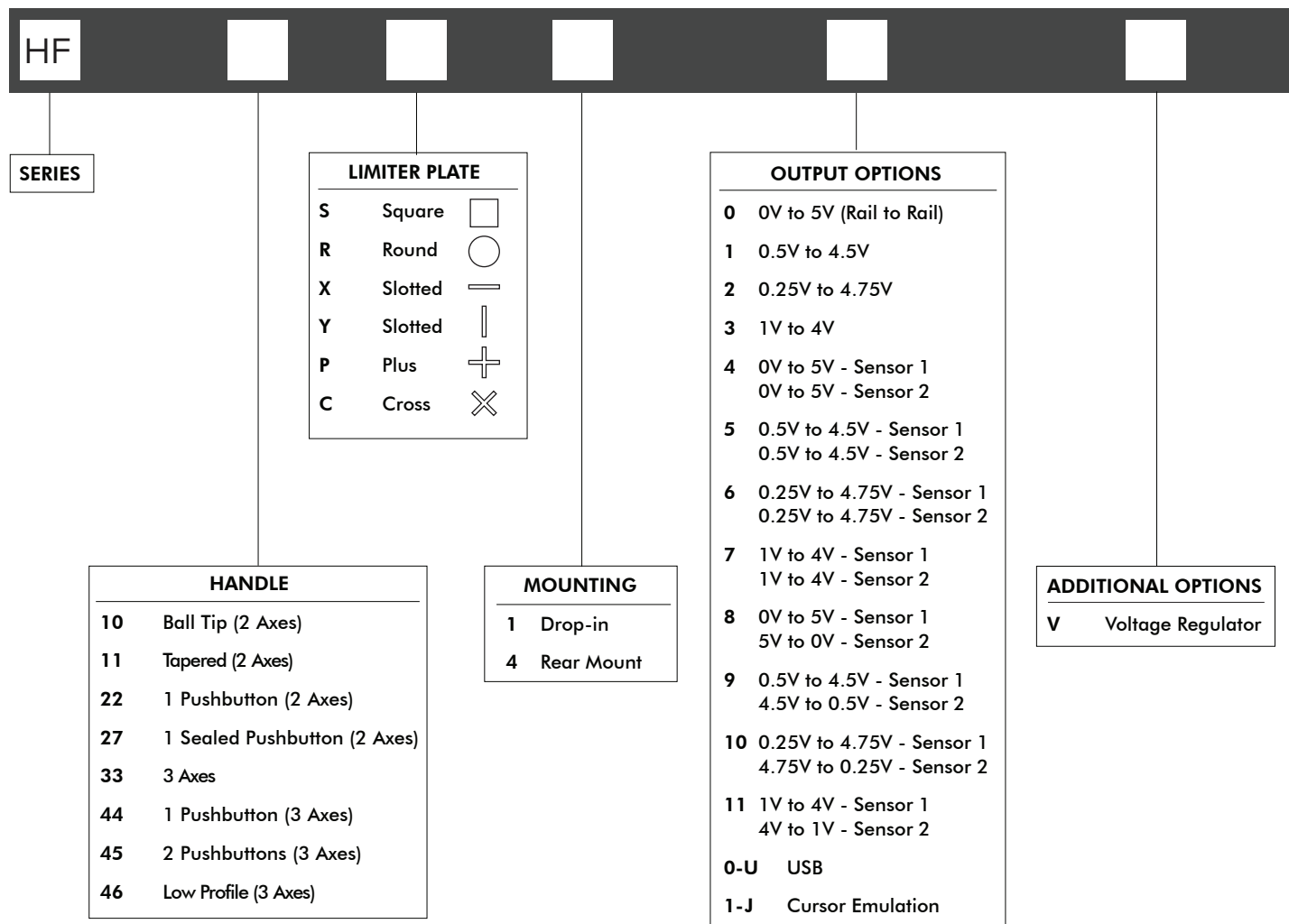

**NOTES**

- The HF Series joysticks are supplied with a Hirose DF11-12DP-2DS9(24) connector (male receptacle). (Fig 1) Standard cable available. Please request at order entry. Cable connector (female socket) is Hirose DF11-12DS-2C. (Fig 2) Connector specifications: 12 position 2mm pitch dual row (2x6) pin header.

WIRE COLOR	DESCRIPTION
Black	Ground
Red	Power
Blue/White	X-Axis (Dual Output)
Blue	X-Axis
Yellow/Black	Y-Axis (Dual Output)
Yellow	Y-Axis
Green/Black	Z-Axis (Dual Output)
Green	Z-Axis
Orange	Button 1
White	Button Common
Violet	Button 2



Fig 1



Fig 2

- Dual Decode cannot be used with USB or Voltage Regulator.



Up to IP68 available.



Mounting accessories. Standard hardware includes: gasket, clamping ring, and four 40-3/4Phil Ph MS SS screws.

# HF series

## Hall effect joysticks

### SPECIFICATIONS

#### MECHANICAL (FOR X, Y AXES)

Break Out Force	–	1.3N (0.3lbf)
Operating Force	–	2.8N (0.63lbf)
Maximum Applied Force	–	200N (45.00lbf)
Mechanical Angle of Movement	–	36° (18° from center)
Expected Life	–	5 million
Material	–	Glass filled nylon
Package Size	–	5.75" x 4.50" x 3.25"
Lever Action	–	Single spring, omnidirectional
Material	–	Glassfilled nylon

#### MECHANICAL (FOR Z AXIS)

Break Out Torque	–	0.09N·m (0.80lbf-in)
Operating Torque	–	0.121N·m(1.07lbf-in)
Maximum Allowable Torque	–	0.150N·m(1.33lbf-in)
Hand Mechanical Angle	–	60° (30° from center)
Handle Action	–	Spring centering, rotational
Expected Life	–	5 million

#### ENVIRONMENTAL

Operating Temperature	–	0°C to 85°C (-13°F to 158°F)
Storage Temperature	–	Up to 85°C (-40°F to 158°F)
Sealing (IP)	–	Up to IP68*
EMC Immunity Level (V/M)	–	EN61000-4-3
EMC Emissions Level	–	EN61000-6-3:2001
ESD	–	EN61000-4-2

#### ELECTRICAL

Sensor	–	Hall effect
Resolution	–	1.22mV
Supply Voltage Operating	–	5VDC±0.01VDC
Reverse Polarity Max	–	-10VDC
Overvoltage Max	–	20VDC
Output Voltage	–	See options
Output Impedance	–	2Ω
Return to Center Voltage (No Load)	–	±200mV
Error signal	–	1.0%

#### NOTES:

- All values are nominal
- Exact specifications may be subject to configuration. Contact Technical Support for the performance of your specific configuration
- \* Excludes some handle options



# HF series

## Hall effect joysticks

### DIMENSIONAL DRAWINGS

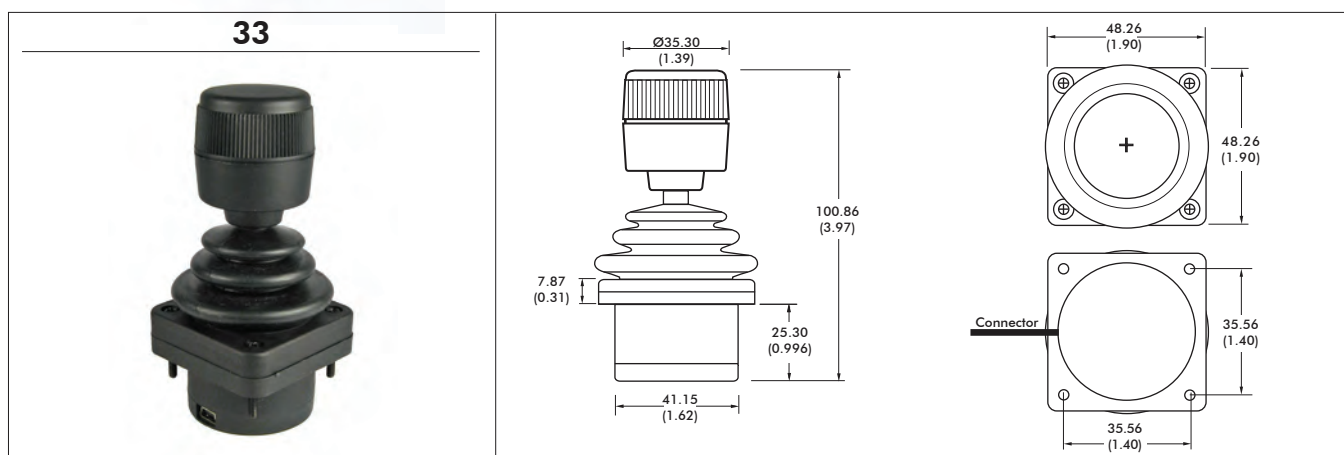
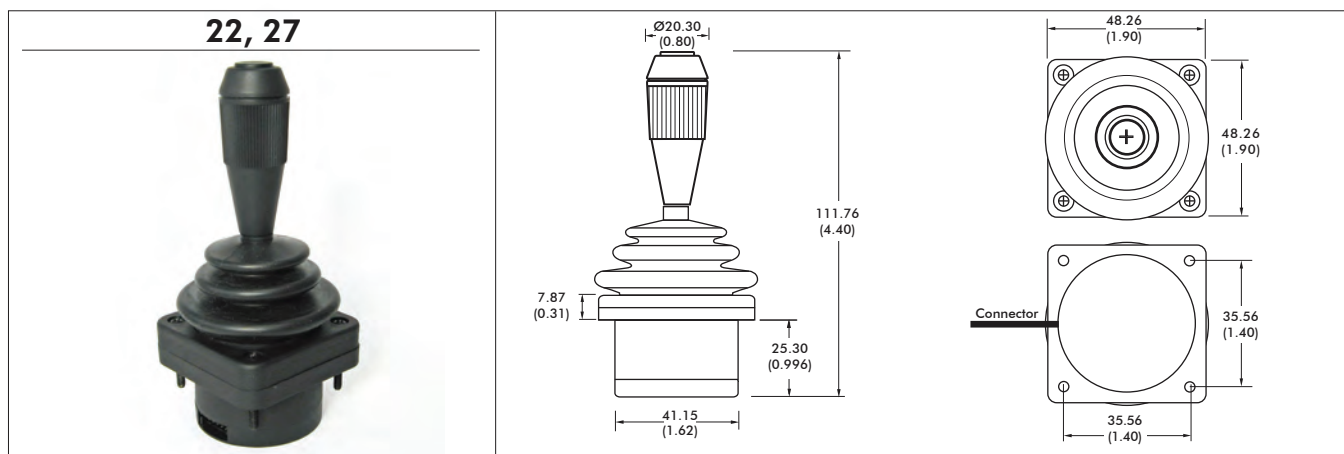
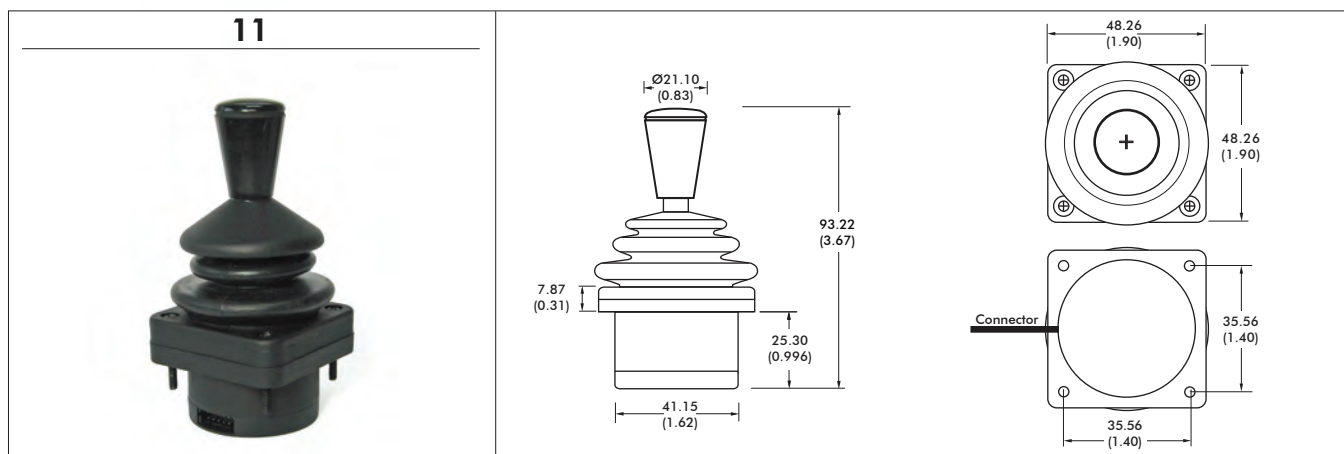
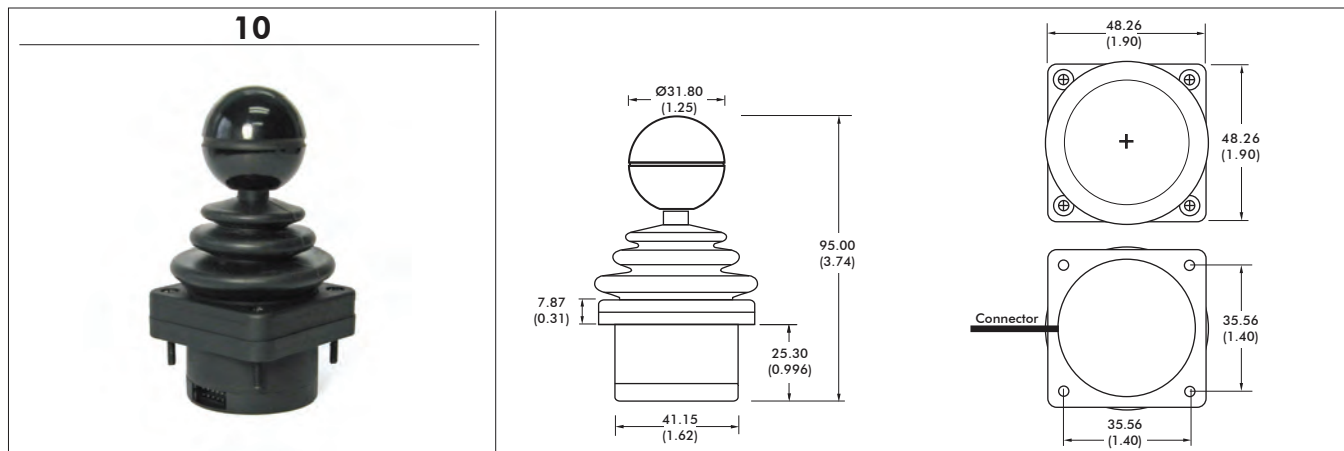

# HF series

## Hall effect joysticks

### DIMENSIONAL DRAWINGS

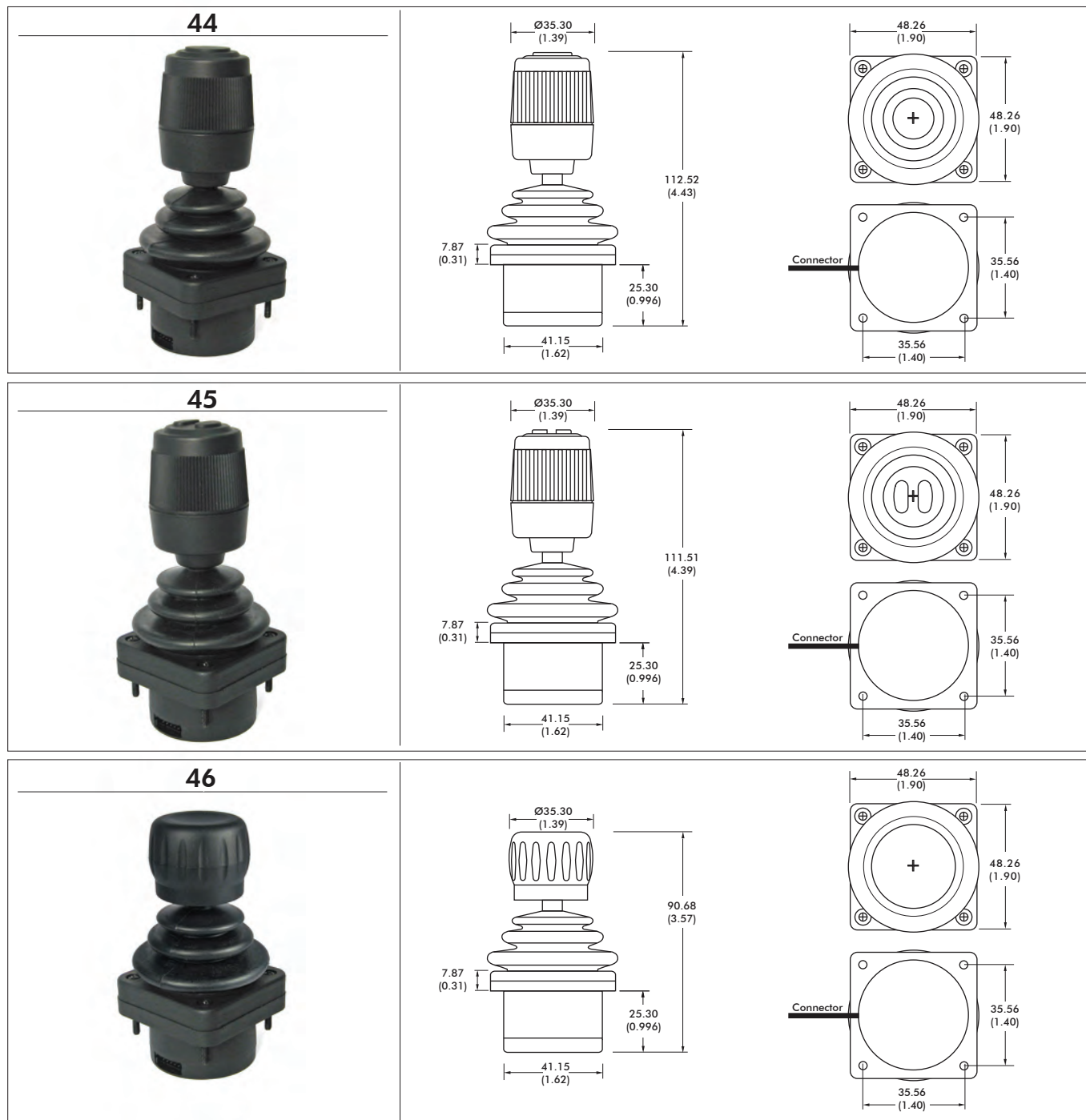

**NOTES:**

1. Dimensions are in mm/(inch)
2. Axes orientation:

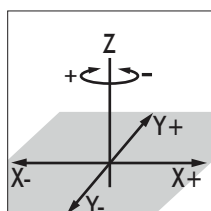

# HF series

## Hall effect joysticks

### DIMENSIONAL DRAWINGS - continued

#### PANEL CUTOUT DIMENSIONS

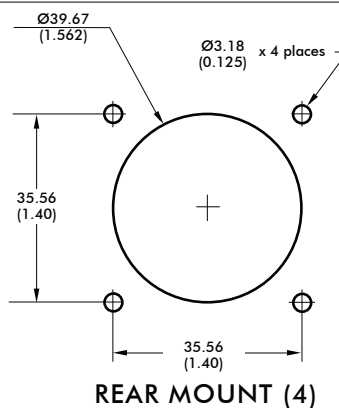
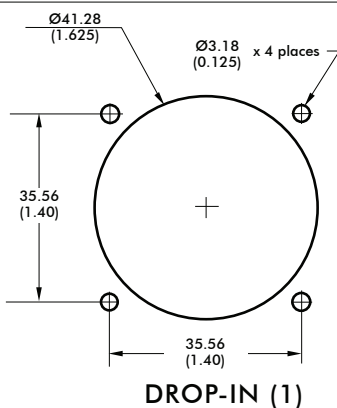

\* Not available for Option 11 Handle

#### MOUNTING OPTIONS

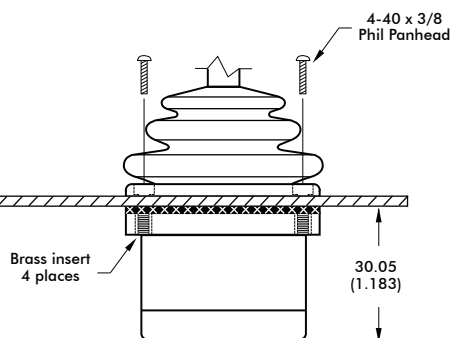
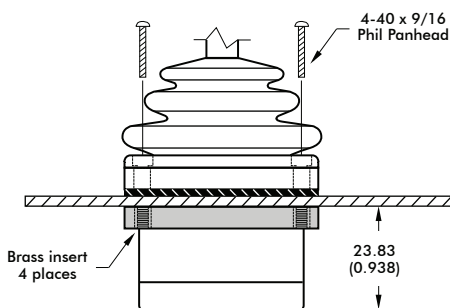

#### CLAMPING RING

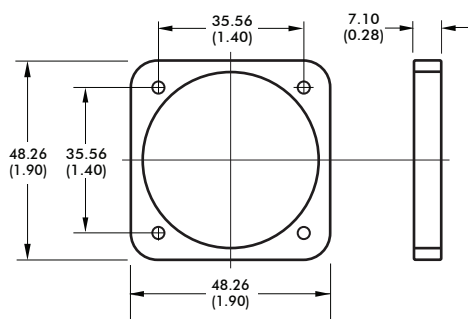

#### NOTES:

- For DROP-IN mounting, the panel thickness can be 1.17mm to 3.17mm (0.046in to 0.125in).
- For REAR MOUNT the maximum panel thickness is 1.6mm (0.063in).
- A panel thickness of 1/16" (1.6mm/0.063in) was considered for all the below-panel depth values.
- The below-panel depth is extended by 7.11 mm (0.28in) with the Joyball, USB, CANbus, Voltage Regulator, dual Decode, Center Detect, Discrete Board, Analog Deadband, and Dual Sensor options.

- Panel
- Gasket
- Rear Mount Gasket

# HF series

## Hall effect joysticks

### CONFIGURATION OPTIONS

#### LINEAR OUTPUT OPTIONS

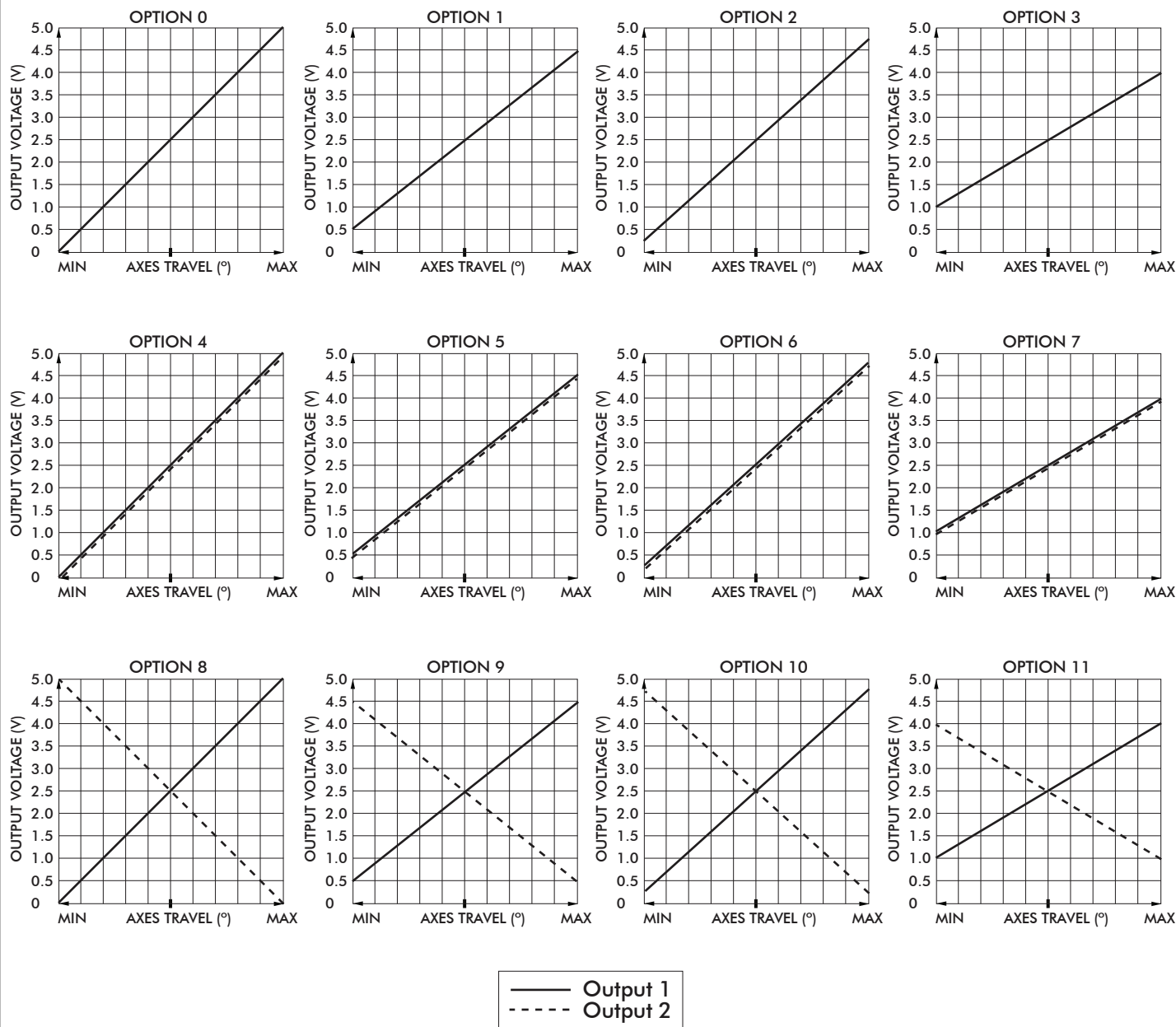



# HF series

## Hall effect joysticks

### CONFIGURATION OPTIONS - continued

#### ADDITIONAL OUTPUT OPTIONS

#### PLUG-AND-PLAY SOLUTIONS:

#### USB

Featuring USB 1.1 HID compliant interface, CH Products' USB joysticks are recognized as standard HID "game controller" devices. Adhering to the HID specification, CH Products' USB joysticks are plug-and-play with most versions of Windows and Linux. Joystick button and axes assignments are dependent upon the controlled application.

#### FEATURES

- USB 1.1 HID compliant "game controller" device
- Easy to install and operate
- Functions determined by controlled application
- Standard Male Type A Connector



USB Male Type A Connector

#### SUPPLIED WIRING

USB: USB Male Type A Connector with overmolded cable  
(Optional ruggedized military connectors are available.)

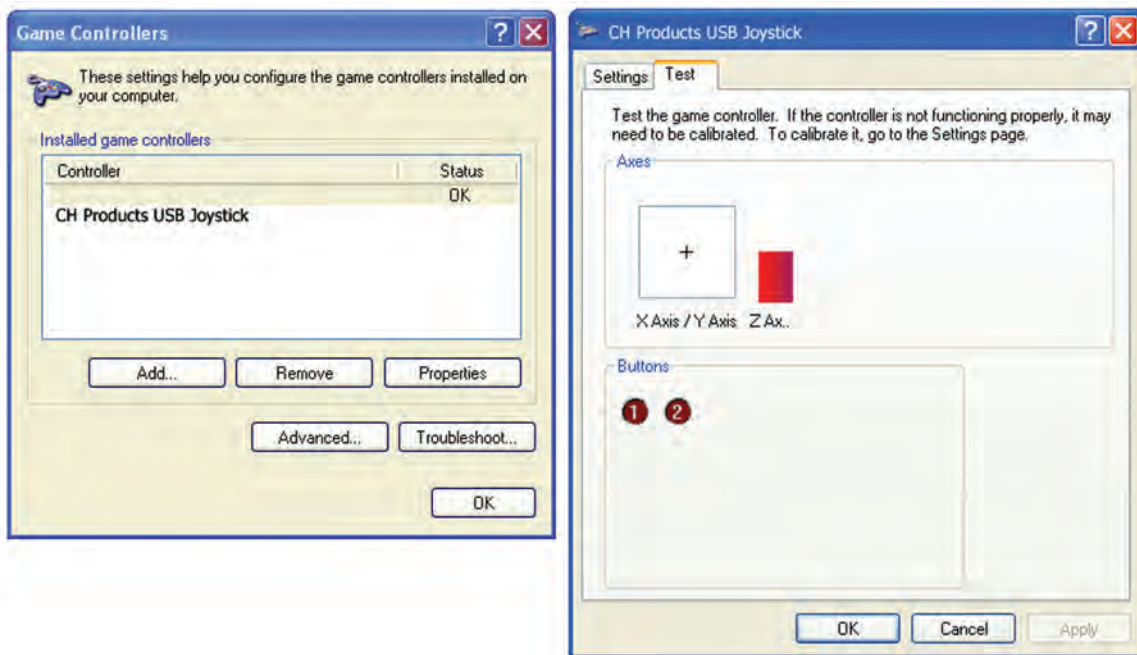

# HF series

Hall effect joysticks

CONFIGURATION OPTIONS - continued

## ADDITIONAL OUTPUT OPTIONS

### PLUG-AND-PLAY SOLUTIONS:

### JOYBALL (CURSOR EMULATION)

The Joyball option converts multi-axis joystick output into a mouse, trackball, or cursor control device. The joystick's internal microprocessor converts absolute axis position into a cursor velocity, which is translated as a relative trackball or mouse position. Supported protocols include Sun Microsystems (mouse systems 5vdc serial) and USB.

#### APPLICATIONS

The Joyball option is ideal for vehicle applications subjected to dirt and high vibration which makes operating a traditional cursor control device difficult. The Joyball option is widely used in marine and military applications.

#### FEATURES

- HID compliant "pointing device"
- Plug-and-play with USB option
- Ideal for marine GPS and navigation
- Environmental sealing up to IP68

#### SUPPLIED WIRING

USB: USB Male Type A Connector with overmolded cable

SUN: SUN mini-DIN plug with overmolded cable and strain relief

#### I/O COMPLEMENT/ USER SPECIFIED PARAMETERS:

- USB 4 pushbuttons 2 or 3 axes (X, Y, and Z "scroll")
- SUN 2 pushbuttons and 2 axes (X, Y)

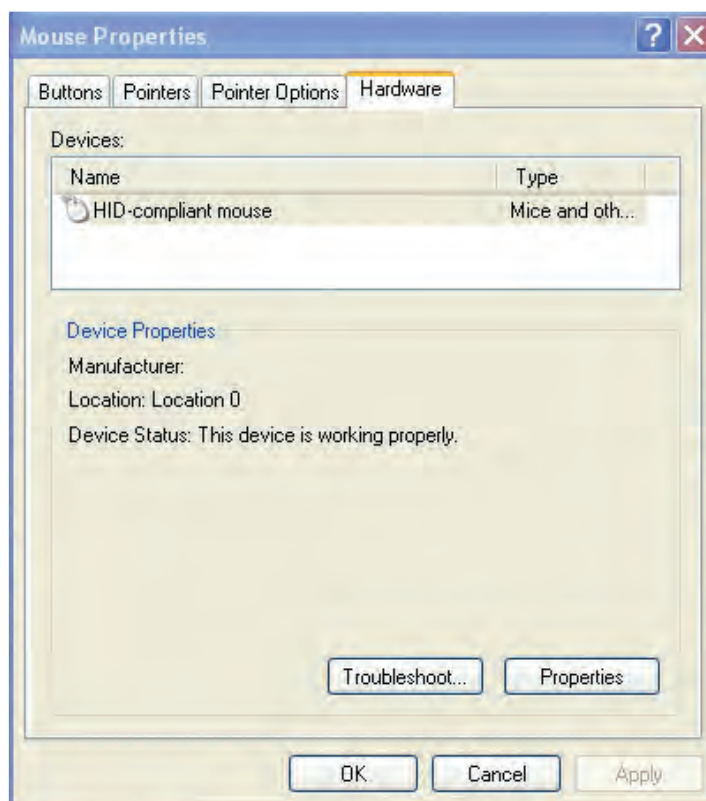

# HF series

Hall effect joysticks

CONFIGURATION OPTIONS - continued

## ADDITIONAL OUTPUT OPTIONS

### VOLTAGE REGULATOR

The Voltage Regulator is a multi-wired analog option used to mate to a variety of industrial control voltages. The Voltage Regulator may be used when the supply or output voltage is greater than 5V or when bipolar output is required.

User Specified Supply Voltage:

- 5 VDC
- 10 VDC
- 12 VDC
- 24 – 30 VDC
- Custom supply options available.

User Specified Output Voltage:

- 0-5 VDC
- 0-10 VDC
- +/-5 VDC
- +/-10 VDC
- Custom outputs available.

### ELECTRICAL SPECIFICATIONS

Supply Power	-	5VDC to 30VDC
Supply Current	-	90mA max

### WIRING SPECIFICATION

Red wire	-	Supply power 5-30VDC
Black wire	-	Ground
Blue wire	-	X axis output
Yellow wire	-	Y axis output
Green wire	-	Z axis output
White wire	-	Pushbutton common wire
Orange,violet,gre,y,brown,pink,bl/wt/y/bk,gn/bk,gy/w wire	-	Pushbutton outputs



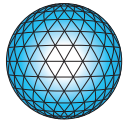

# APEM

## 3000 series

Premium Hall effect joysticks



The 3000 Series is the very latest generation in high precision contactless joysticks. With a class leading installed depth of <math><20\text{mm}</math>, it is available in 1, 2 or 3 axes formats. Long trouble-free life is assured with the latest hall effect technology, providing a range of analog signals or custom PWM output options. The 3000 Series also delivers a radically improved mechanism construction that is specifically designed for increased robustness, strength and performance.



### KEY FEATURES

- Class leading installed depth <math><20\text{ mm}</math>
- Hall effect sensing
- 1, 2 or 3 axes
- 5V or 3.3V operation
- EMC shielded
- Analog or PWM outputs
- Next generation metal mechanisms
- Dual outputs available





# 3000 series

## Premium Hall effect joysticks

### OPTION SELECTION

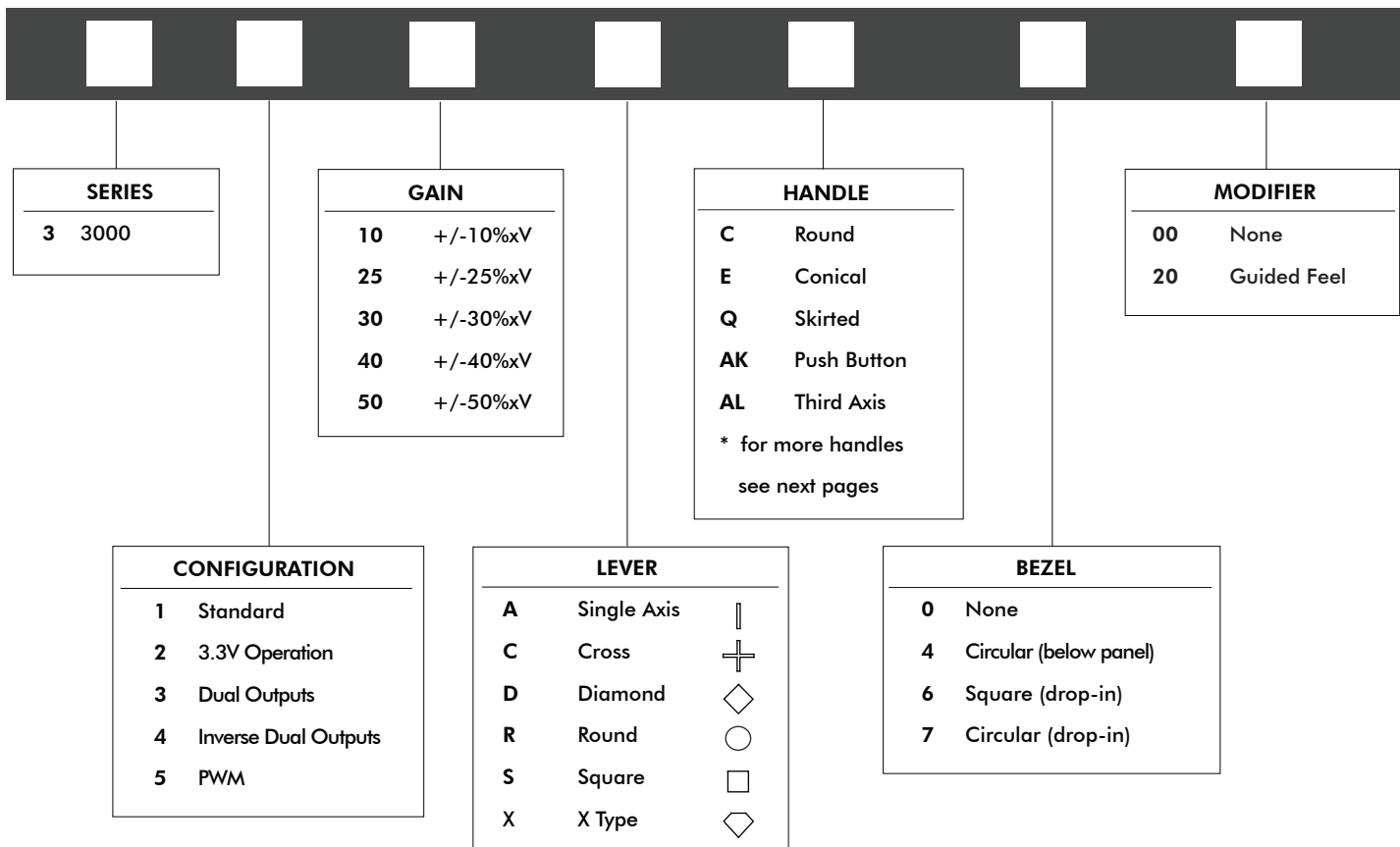

- **CONFIGURATION 1** provides one proportional output per axis, a center tap reference and a separate center detect output.
- **CONFIGURATION 2** is offered as standard with +/-50% gain, yielding a voltage span from 0V (South) to 3.3V (North).
- **CONFIGURATION 3** joystick operates on 5V and provides two outputs per axis of the same polarity for example Y, Y & X, X. The second set of outputs are accurate to the first within +/-5% of the power supply. The power supply and center tap for the secondary outputs are also completely independent.
- **CONFIGURATION 4** The secondary outputs are of inverse polarity to the primary wipers for example X, -X & Y, -Y. The first and second outputs can be summed and compared to Center Tap to verify that the joystick is operating correctly.
- **CONFIGURATION 5** Operating on a 5V supply the 3000 Series may be selected with a variety of PWM output options. For more details on the type of outputs available please refer to Apem.

Note: The 3.3V supply is created by additional DC/DC conversion within the joystick and therefore the power consumption is greater than a 5V supplied product.

#### STANDARD OPTION AVAILABILITY

The following table shows which permutations of options are possible.

CONFIGURATION	CT	CD	AXES			SUPPLY		GAIN					LIMITERS					ALL HANDLES	ALL BEZELS			
			X	Y	Z	3.3	5V	10	25	30	40	50	A	C	D	R	S			X		
1	✓	✓	✓	✓	✓	✗	✓	✓	✓	✓	✓	✓	✓	✓	✓	✓	✓	✓	✓	✓	✓	✓
2	✗	✗	✓	✓	✓	✓	✗	✗	✗	✗	✗	✗	✓	✓	✓	✓	✓	✓	✓	✓	✓	✓
3	✗	✗	✓	✓	✓	✗	✓	✓	✓	✓	✓	✓	✓	✓	✓	✓	✓	✓	✓	✓	✓	✓
4	✗	✗	✓	✓	✓	✗	✓	✓	✓	✓	✓	✓	✓	✓	✓	✓	✓	✓	✓	✓	✓	✓
5	✗	✗	✓	✓	✓	✗	✓	✗	✗	✗	✗	✗	✗	✓	✓	✓	✓	✓	✓	✓	✓	✓

#### HANDLE AND BEZEL OPTIONS

For drop in mounting, please specify bezel option 6 or 7. For sub-panel mounting, no bezel is necessary, unless the boot is required to seal to the face of the panel in which case bezel option 4 should be specified. Further mounting information including panel cutouts are shown on the following pages.

# 3000 series

## Premium Hall effect joysticks

### SPECIFICATIONS

#### MECHANICAL

Materials Employed	-	Shaft - Stainless Steel Boot - Neoprene Others - Brass, Nylon, ABS
Weight	-	100g (0.20lb) nominal
Breakout Force	-	1.3N (2.86lbf)
Mechanical Angle of Movement	-	36° for X and Y axes (subject to limiter) 50° for Z axis (subject to handle)
Max Load to Mechanism	-	400N (881.85lbf)

#### ENVIRONMENTAL

Storage	-	-40C to +70C
Operating Temperature	-	-25C to +70C
Seal Above Panel	-	IP65 - Neoprene boot fitted as standard
EMC Emission	-	Complies with EN 61000-6-3:200, CISPR 22:2005 Class B 30MHz-11GHz
Life Cycles	-	10,000,000 cycles (5,000,000 for 3 axes joysticks)
ESD	-	Complies with EN61000-4-2 (extended) +/-8KV (20 contacts) & +/-15KV (20 air discharges)
EMC Immunity	-	100V/m, 80MHz-2.7GHz, 1KHz 80% sine wave modulation, EN 61000-4-3 (extended)
Vibration	-	100Hz - 200Hz @ 0.13g /Hz, total 3.6gRMS (1 Hour in each of the three mutually perpendicular axes)

#### ELECTRICAL

Gain (Output Voltage Span)	-	+/-10% x V to +/-50% x V
Output at Center	-	V/2 +/- (5% x Gain)
Power Supply	-	5V +/-0.5V Transient free (Configs 1, 2, 3, 4 & 5) or 3.3V +/-0.1V (Config 2)
Center Tap Impedance	-	1K1
Center Detect Output	-	Pulled high within joystick via 2K2 to +V, and smoothed to 0V with 100nF
Sensor Type	-	Hall effect
Current Consumption	-	5V - <13mA (Two axes) - <20mA (Three axes) 3.3V - <24mA (Two axes) - <40mA (Three axes)
Loads	-	Minimum 10K, preferred 100K+

#### NOTES:

- All values are nominal
- All specifications shown are based on a standard configuration and are provided for guidance only.
- Please refer to Apem for assistance on how to achieve the best performance from your chosen configuration.
- Current consumption may be greater for dual output configurations.

# 3000 series

## Premium Hall effect joysticks

### DIMENSIONAL DRAWINGS - HANDLES

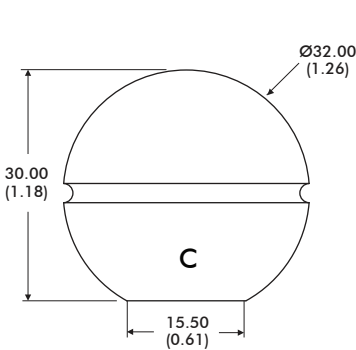
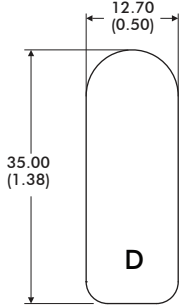
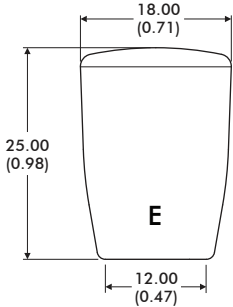
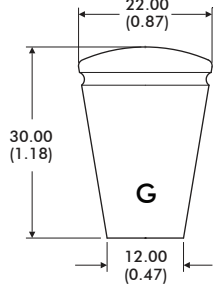
			
<p><b>MATERIAL</b> Phenolic  <b>FINISH</b> Gloss  <b>STANDARD COLOR</b> Black  <b>OTHER COLORS</b> Not Available  <b>NOTES:</b></p>	<p><b>MATERIAL</b> Aluminum  <b>FINISH</b> Anodised  <b>STANDARD COLOR</b> Black  <b>OTHER COLORS</b> Not Available</p>	<p><b>MATERIAL</b> Nylon  <b>FINISH</b> Sparked Matt  <b>STANDARD COLOR</b> Black  <b>OTHER COLORS</b> Upon Request</p>	<p><b>MATERIAL</b> Phenolic  <b>FINISH</b> Gloss  <b>STANDARD COLOR</b> Black  <b>OTHER COLORS</b> Not Available</p>

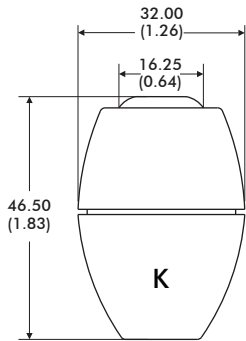
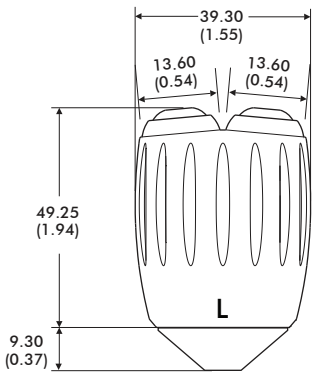
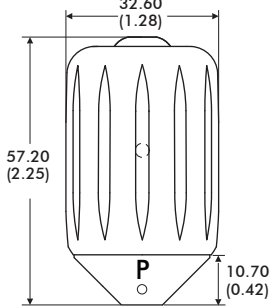
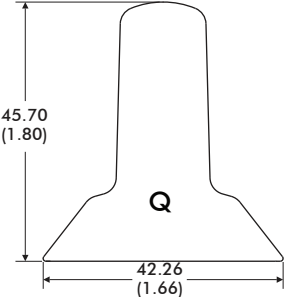
			
<p><b>MATERIAL</b> ABS  <b>FINISH</b> Sparked Matt  <b>STANDARD COLOR</b> Black  <b>OTHER COLORS</b> Upon Request  <b>NOTES:</b> Uses APEM IS Switch</p>	<p><b>MATERIAL</b> Aluminum  <b>FINISH</b> Anodised  <b>STANDARD COLOR</b> Black  <b>OTHER COLORS</b> Not Available  <b>NOTES:</b> Uses APEM IS Switch                  Z axis functionality</p>	<p><b>MATERIAL</b> Aluminum  <b>FINISH</b> Anodised  <b>STANDARD COLOR</b> Black  <b>OTHER COLORS</b> Not Available  <b>NOTES:</b> Uses APEM IS Switch                  Z axis functionality</p>	<p><b>MATERIAL</b> Nylon  <b>FINISH</b> Sparked Matt  <b>STANDARD COLOR</b> Black  <b>OTHER COLORS</b> Upon Request</p>

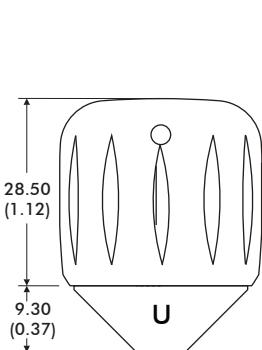
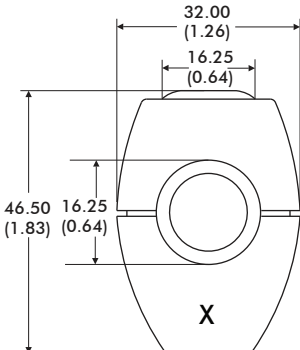
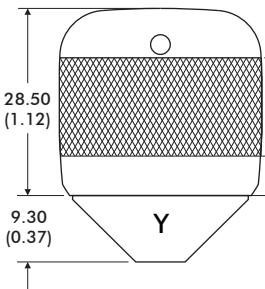
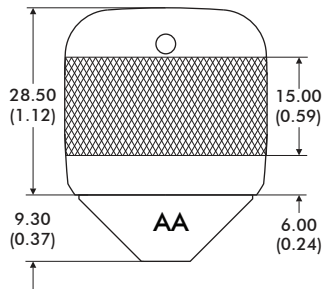
			
<p><b>MATERIAL</b> Aluminium  <b>FINISH</b> Anodised  <b>STANDARD COLOR</b> Black  <b>OTHER COLORS</b> Not available  <b>NOTES:</b></p>	<p><b>MATERIAL</b> ABS  <b>FINISH</b> Sparked Matt  <b>STANDARD COLOR</b> Black  <b>OTHER COLORS</b> Upon Request  <b>NOTES:</b> Uses APEM IS Switches</p>	<p><b>MATERIAL</b> Aluminium  <b>FINISH</b> Anodised with Diamond Knurl  <b>STANDARD COLOR</b> Black  <b>OTHER COLORS</b> Not Available  <b>NOTES:</b> Z axis functionality</p>	<p><b>MATERIAL</b> Aluminium  <b>FINISH</b> Anodised with Diamond Knurl  <b>STANDARD COLOR</b> Black  <b>OTHER COLORS</b> Not Available</p>

# 3000 series

## Premium Hall effect joysticks

### DIMENSIONAL DRAWINGS - HANDLES - continued

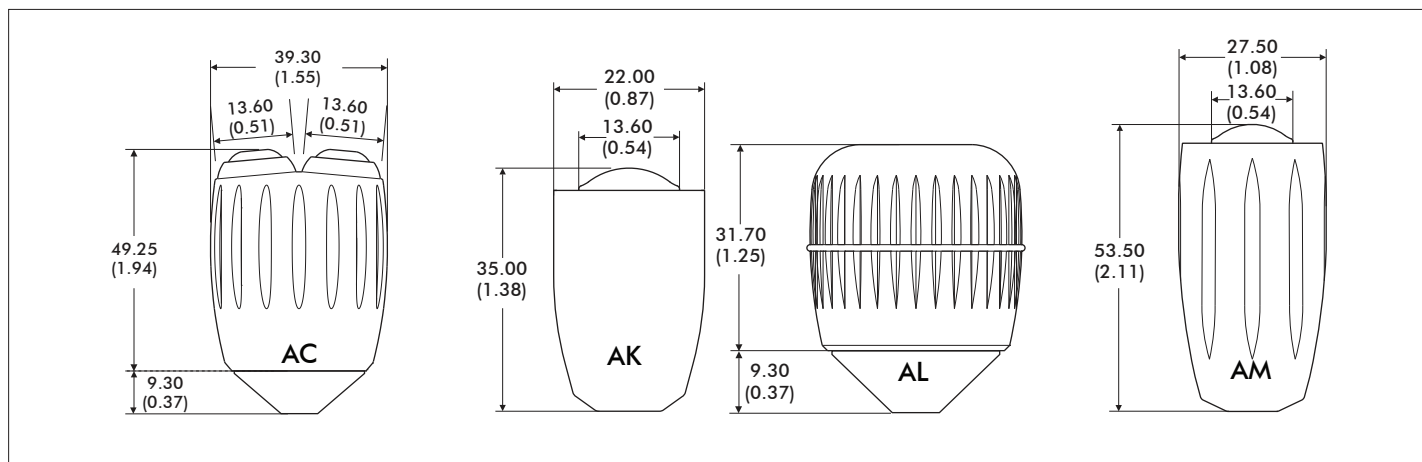

MATERIAL	Aluminum	Aluminum	Nylon	Aluminum
FINISH	Anodised	Anodised	Sparked Matt	Anodised
STANDARD COLOR	Black	Black	Black	Black
OTHER COLORS	Not Available	Not Available	Upon Request	Not Available
NOTES:	Uses APEM IS Switches	Uses APEM IA Switch	Z axis functionality	Uses APEM IA Switch

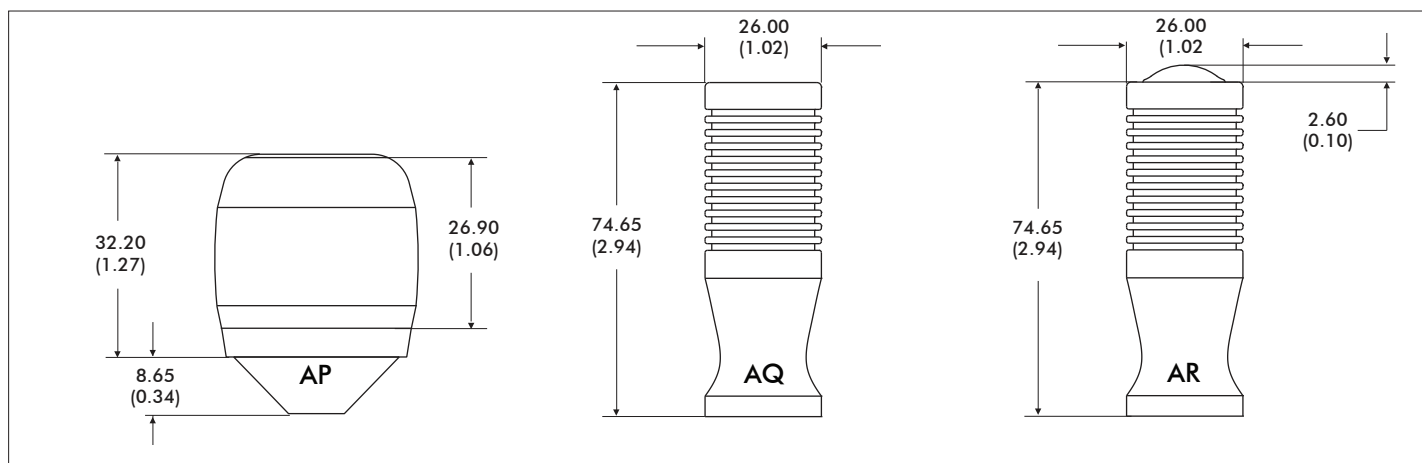

MATERIAL	Santoprene over Nylon	Aluminum	Aluminum
FINISH	Soft Touch	Anodised	Anodised
STANDARD COLOR	Black	Black	Black
OTHER COLORS	Upon Request	Not Available	Not Available
NOTES:	Z axis functionality		Uses APEM IA Switch

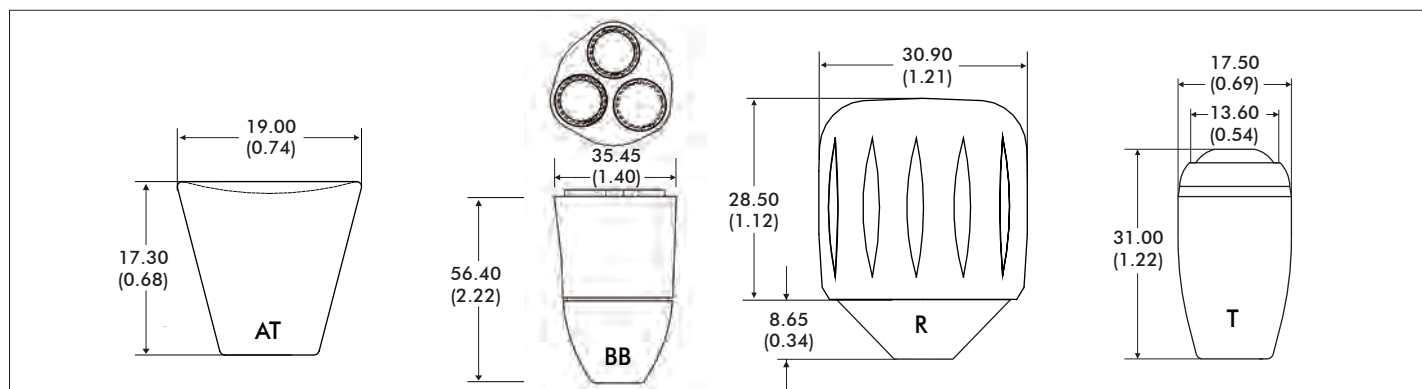

MATERIAL	Nylon	Nylon	Aluminum	Stainless Steel
FINISH	Sparked Matt	Sparked Matt	Anodised	Natural
STANDARD COLOR	Black	Black	Black	Stainless Steel
OTHER COLORS	Upon Request	Not Available	Not Available	Not Available
NOTES:		Uses APEM IL switch	Z axis functionality	Uses APEM IS switch

1. Dimensions are in mm/(inch)

# 3000 series

Premium Hall effect joysticks

DIMENSIONAL DRAWINGS - continued

## GENERAL DIMENSIONS

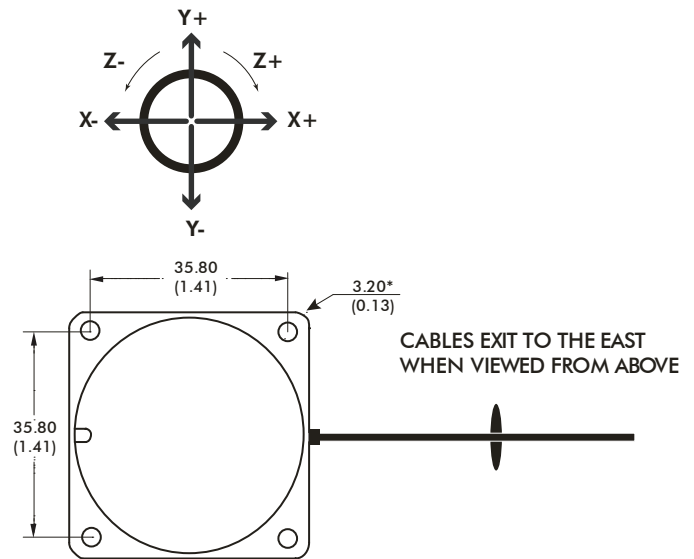
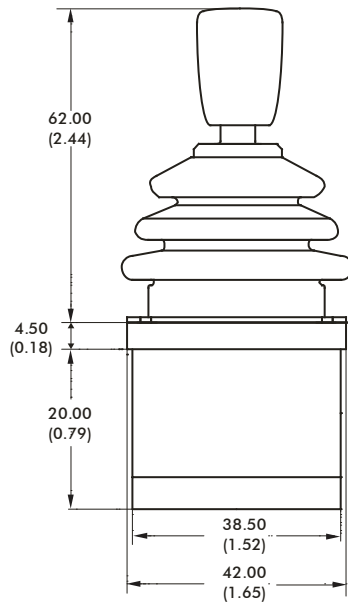

## DROP IN MOUNTING - PANEL CUT-OUT & MOUNTING INSTALLATION

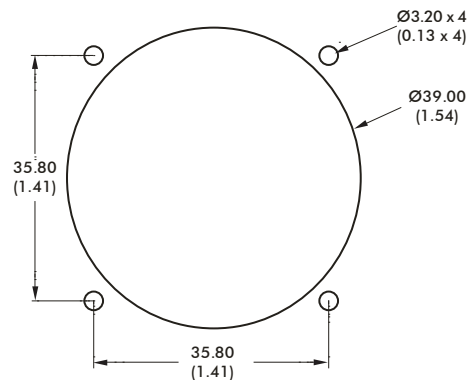

The joystick is dropped into the panel cut-out. For panel thickness of <3mm, M3 x 16 countersunk machine screws are recommended. Please note: Image (left) shows a square bezel, a circular bezel is also available for this option.

### NOTES:

1. Dimensions are in mm/(inch)
2. The dimensions shown are for generic 3000 series with E type handle. For specific dimensions of this or any other configuration please refer to Apem.

\*3000 Series has slotted mounting holes - allows compatibility with mounting pitches of 32.25mm to 35.80mm



# 3000 series

## Premium Hall effect joysticks

### MOUNTING INSTALLATION

#### SUB MOUNTING OPTION A - PANEL CUT-OUT & MOUNTING INSTALLATION

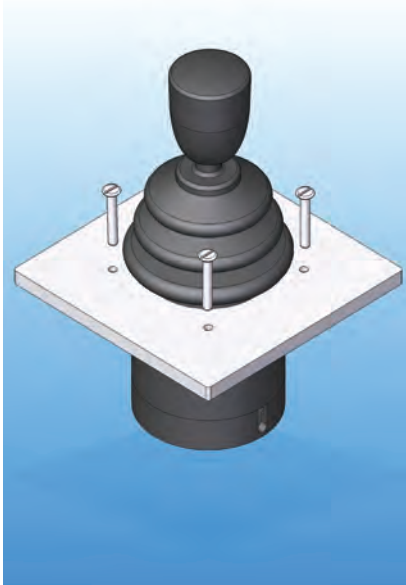

#### MOUNTING CUT-OUT

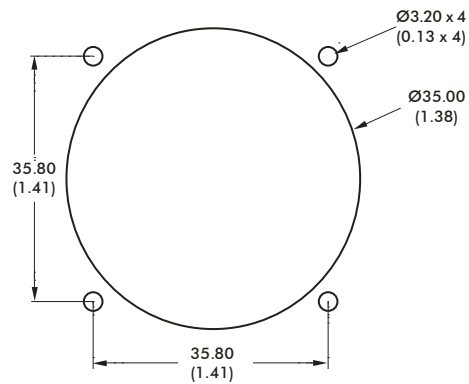

When mounted this way the panel acts as the bezel and no separate bezel is needed. M3 machine screws are recommended.

#### SUB MOUNTING OPTION B - PANEL CUT-OUT AND MOUNTING INSTALATION

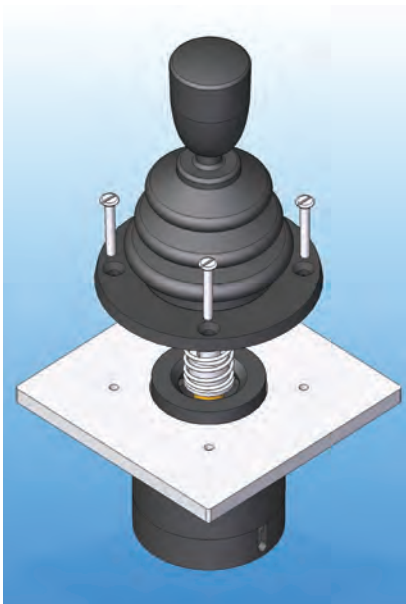

#### MOUNTING CUT-OUT

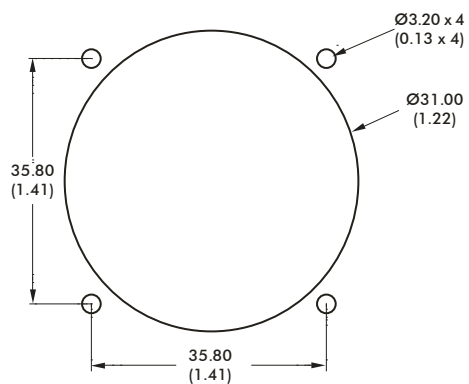

The joystick is mounted beneath the panel and the base of the boot must be brought through the panel cut-out and held in place with the circular bezel. For panel thickness of <3mm, M3 x 16 countersunk machine screws are recommended.

#### NOTES:

1. Dimensions are in mm/(inch)
2. When sub panel mounting, great care should be taken not to damage the boot, or any of the mechanism under the boot. All panell cut-outs should be free from sharp edges and debris that may damage the boot.

# 3000 series

## Premium Hall effect joysticks

### CONFIGURATION OPTIONS

#### LINEAR OUTPUT OPTIONS

##### SINGLE OUTPUT - CONFIGURATION 1

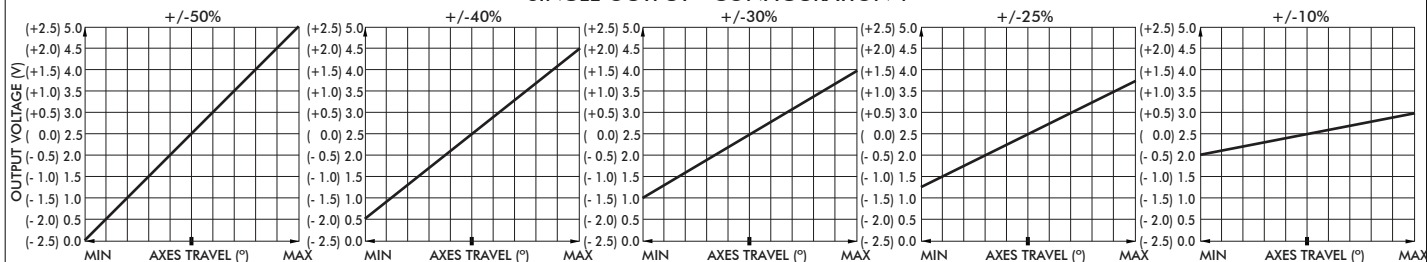

##### DUAL OUTPUT - CONFIGURATION 3

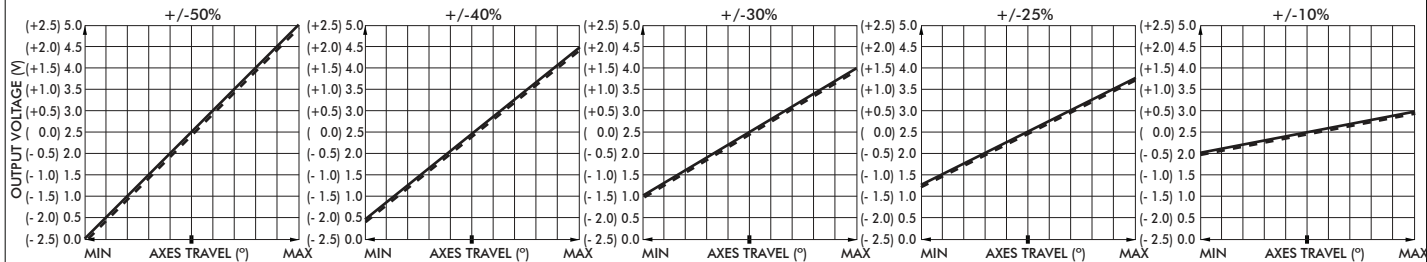

##### DUAL OUTPUT - CONFIGURATION 4

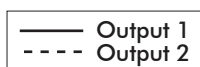
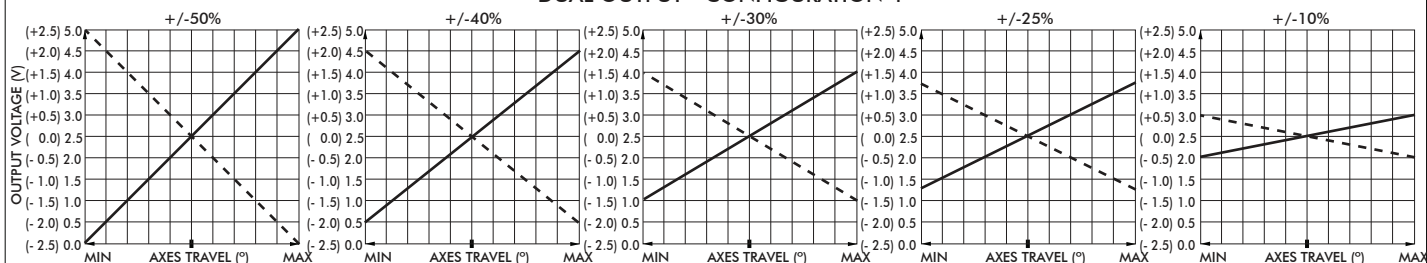

#### POWER SUPPLY

The 3000 Series is designed to be powered by a regulated 5V +/- 0.5V power supply. The outputs are ratiometric, making a stable, noise free, power supply essential. The 3.3V version of the 3000 Series requires a power supply accurate to +/-0.1V. The outputs are not ratiometric, the voltage gain is set to 50% as standard, giving an output range from 0 to 3.3V regardless of supply voltage. The power supply to the joystick should be carefully regulated to be within tolerance. Should the power supply change outside of the specified tolerances, permanent damage may occur.

#### MAGNETIC IMMUNITY AND SYSTEM DESIGN

The 3000 Series incorporates internal magnetic screening to minimise the effect of external magnetic fields. Mounting or operating the joystick close to strong magnetic fields is not recommended. System designers should follow best practice when incorporating the 3000 Series joystick into their products. Care should be taken to decouple the power supply properly and to employ adequate EMC shielding.

#### MOUNTING

When mounting the joystick, care should be taken to site it in a position that does not make it vulnerable to damage when in use. If the joystick is intended for use in a handheld enclosure then care must be taken to protect the joystick from damage caused by dropping. Basic precautions such as mounting it at the lightest end of the enclosure so it doesn't hit the ground first or by protecting it with a guard should always be implemented for long term reliability. The body of the joystick, on the underside of the panel, must not be subject to water spray, excessive humidity or dust.

# 3000 series

## Premium Hall effect joysticks

### CONFIGURATION OPTIONS - continued

#### CENTER DETECT (CD)

Where selected, (configuration 1 types) the output on this additional cable will be 0V while the joystick is inactive. Should either the X or Y outputs change outside of the centre tolerance, indicating that the joystick has been operated, the center detect signal will switch to 5V. Within the joystick this output is pulled high by a 2K2 resistor and is decoupled by a 100nF capacitor to 0V. This output is designed for use in applications requiring an enable/disable signal that is separate from the main wipers. It is not recommended for use as a safety feature or a method of "person-present" detection.

#### CENTER TAP REFERENCE (CT)

Where selected, (configurations 1, 3 and 4) the joystick also outputs a centre reference voltage that is set at 50% (+/-1%) of the supply voltage. This output can be used to check the integrity of the power supply applied to the joystick. A reading on this output, outside of the specified tolerance suggests a problem with the power supply to the joystick. The other purpose of this output is to act as a reference equal to the voltage output when the lever is at center. Measuring the voltage outputs relative to CT rather than 0V eliminates inaccuracies created by variation in supply voltage.

#### GAIN OPTIONS

The voltage output on the wipers, at full scale deflection is determined by the gain. The gain is expressed as a percentage of the voltage supplied. Therefore (assuming a 5V supply) a joystick specified with +/- 25% gain would yield 1.25V at South, 2.5V at centre and 3.75V at North. A range of gain options are available as standard for configurations 1, 3 and 4. All joysticks are supplied pre-set and no further calibration is needed throughout the lifetime of operation.

#### OUTPUT IMPEDANCE

The voltage outputs at center and at each end of travel are specified across an infinite load, with no current flowing. The output impedance specified in the electrical specification should be taken into account when designing a system. Load resistance of less than 10K Ohms is not recommended.

#### MECHANISM

The omni-directional mechanism utilises an extremely robust ball-socket pivot. This construction yields an end product that is extremely resistant to vertical impact. Furthermore it constantly withstands high pull, push, rotational or horizontal forces that the product may be subject to, during life.

#### SPRINGING

All 3000 Series are offered sprung to center. The standard spring force requires 1.3N (nominally) to off-center the joystick. The 3000 Series may be specified with a lighter spring (1N), or a stronger spring (1.6N).

#### GUIDED FEEL

The 3000 Series may also be specified with guided feel. A joystick with guided feel moves more readily towards the poles (N, S, E and W) and whilst it can still move away from the poles, the force required to do so is greater. Unless specified otherwise, joysticks are supplied as standard without guiding. This standard configuration allows the user to move the joystick anywhere within the limiter with the same force and without any bias.

#### CONNECTIONS

The joystick is fitted, as standard, with 150mm long BS6360 rated cables and an industry standard 2.5mm pitch connector(s). Further non-standard connectors and cable options are available upon request.

#### CONFIGURATIONS 1 & 2

Joysticks are supplied with a seven way connector as standard. If the joystick is specified with a pushbutton handle, the connector will be nine way.

- PIN 1:** 0V (Black)
- PIN 2:** Center Tap Reference (Green)
- PIN 3:** Z Axis Output (Purple) - Where Specified
- PIN 4:** Y Axis Output (Yellow)
- PIN 5:** X Axis Output (Blue) - Where Specified
- PIN 6:** +V (Red)
- PIN 7:** Center Detect (Orange)
- PIN 8:** Pushbutton (Orange)
- PIN 9:** Pushbutton (Orange)

#### CONFIGURATIONS 3 & 4

Joysticks are supplied with two completely independent cable assemblies, for a truly dual system.

- PIN 1:** 0V (Black)
  - PIN 2:** Center Tap Reference (Green)
  - PIN 3:** No connection
  - PIN 4:** Y Axis Output (Yellow)
  - PIN 5:** X Axis Output (Blue) - Where Specified
  - PIN 6:** +V (Red)
  - PIN 7:** No connection
- For details on configuration 5 pin out, please refer to Customer Support.



# HT series

Ruggedized Hall effect joysticks



The HT Series joystick is a long life cycle, Hall effect controller providing reliable multi-axes finger positioning control. Available in single, dual, and triple axes configurations, HT Series joysticks are ideal for harsh environments, finger operated applications requiring increased durability and reliability. Widely used applications include on-road enclosed cabin vehicles, unmanned vehicles and military robotics.



## KEY FEATURES

- Rugged finger positioning control
- Available with CANbus J1939
- Available with USB 1.1 HID compliant interface
- 1, 2 and 3 axes configuration
- 10 million life cycles
- Sealing up to IP68





# HT series

## Ruggedized Hall effect joysticks

### OPTION SELECTION

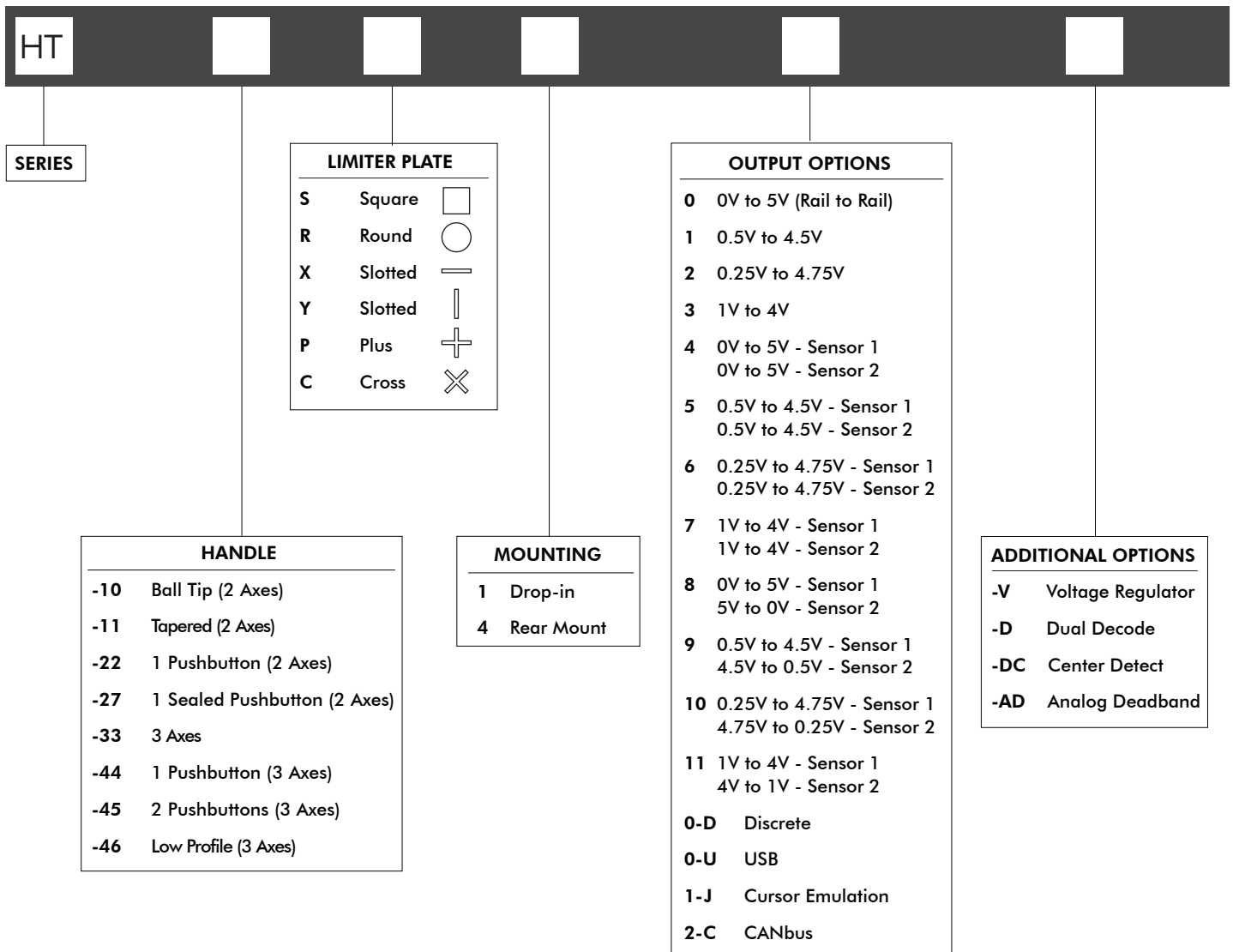

### NOTES

1. Dual Decode cannot be used with CANbus, USB, or Voltage Regulator.



Up to IP68 available.



Mounting accessories. Standard hardware includes: gasket, clamping ring, and four 40-3/4Phil Ph MS SS screws.

# HT series

## Ruggedized Hall effect joysticks

### SPECIFICATIONS

MECHANICAL (FOR X, Y AXES)		
Break Out Force	-	1.8N (0.4lbf)
Operating Force	-	3.5N (0.75lbf)
Maximum Applied Force	-	450N (100lbf)
Mechanical Angle of Movement	-	40°
Expected Life	-	10 million cycles
Material	-	Glass filled nylon
Lever Action	-	Spring centering

MECHANICAL (FOR Z AXIS)		
Break Out Torque	-	0.09N·m (0.80lbf·in)
Operating Torque	-	0.121N·m (1.07lbf·in)
Maximum Allowable Torque	-	0.150N·m (1.33lbf·in)
Hand Mechanical Angle	-	60°
Handle Action	-	Spring centering
Expected Life	-	10 million cycles

ENVIRONMENTAL		
Operating Temperature	-	-25°C to 70°C (-13°F to 158°F)
Storage Temperature	-	-40°C to 70°C (-40°F to 158°F)
Sealing (IP)	-	IP65 to IP68*
EMC Immunity Level (V/M)	-	IEC 61000-4-3: 2006
EMC Emissions Level	-	IEC 61000-4-8: 1993/A1: 2000
ESD	-	IEC 61000-4-2: 2008
Vibration Crash (non operational)	-	IAW MIL-STD-810F Method 516.5 Procedure V, Table 516.5-8 SRS (75G)
Vibration Shock (non operational)	-	IAW MIL-STD-810F, Method 516.5, Procedure 1, 40G peak sine wave pulse with 11ms duration
Vibration Shock (operational)	-	IAW MIL-STD-810F, Method 516.5, Procedure, 20G peak half sine wave pulse with 11ms duration

ELECTRICAL		
Sensor	-	Hall effect
Resolution	-	Infinite
Supply Voltage Operating	-	5.00VDC
Reverse Polarity Max	-	-14.5VDC
Overvoltage Max	-	18VDC
Output Voltage	-	See options
Output Impedance	-	6Ω
Current Consumption Max	-	10mA per axis
Return to Center Voltage (No Load)	-	±200mV
Output Ramp	-	See options

CANbus OUTPUT VERSION		
Supply Voltage Range	-	6V to 40V
CANbus Version	-	J1939

#### NOTES:

- All values are nominal
- Exact specifications may be subject to configuration.  
Contact Technical Support for the performance of your specific configuration.
- \* Excludes some handle options

# HT series

## Ruggedized Hall effect joysticks

### DIMENSIONAL DRAWINGS

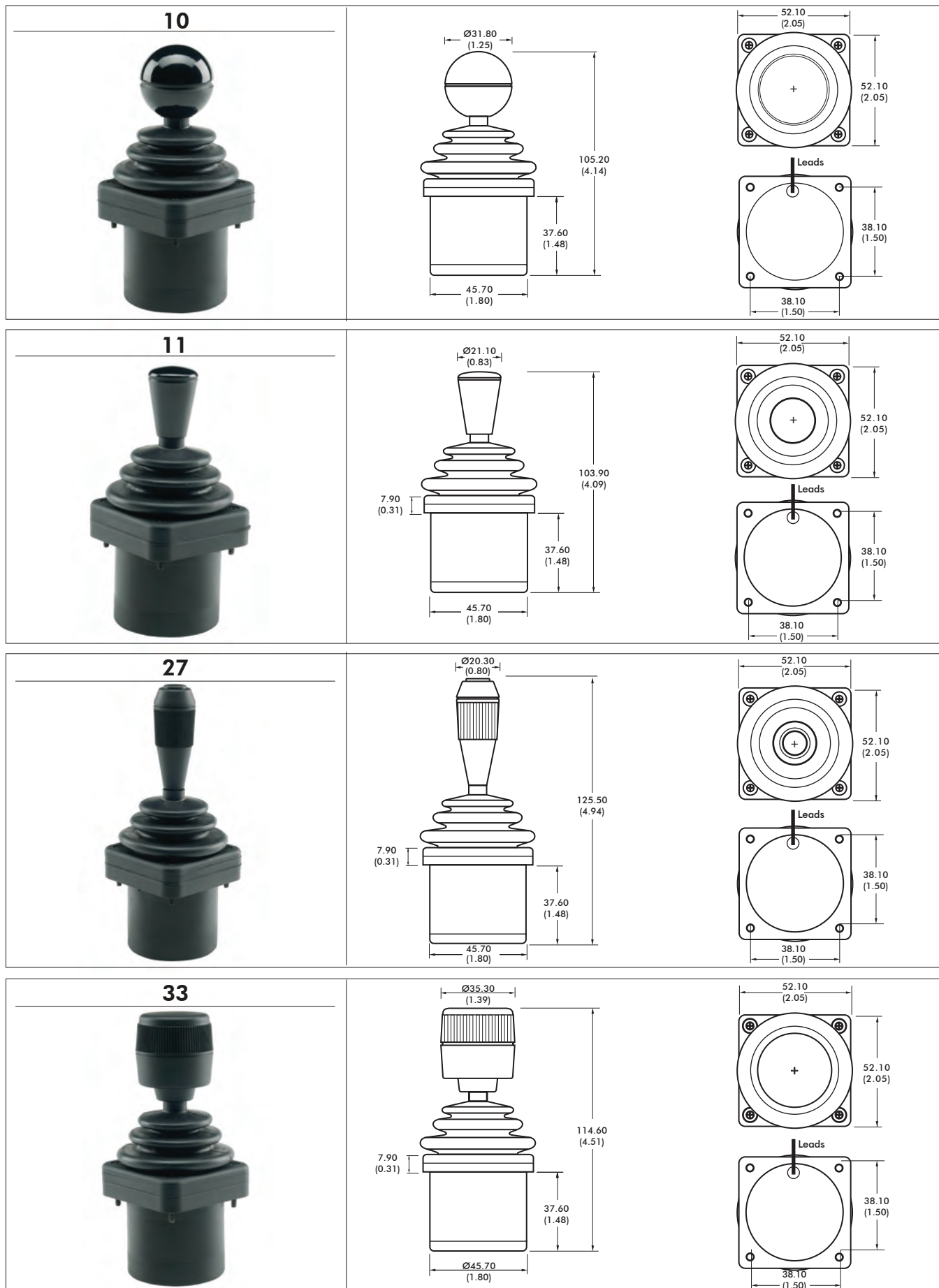

# HT series

## Ruggedized Hall effect joysticks

### DIMENSIONAL DRAWINGS - continued

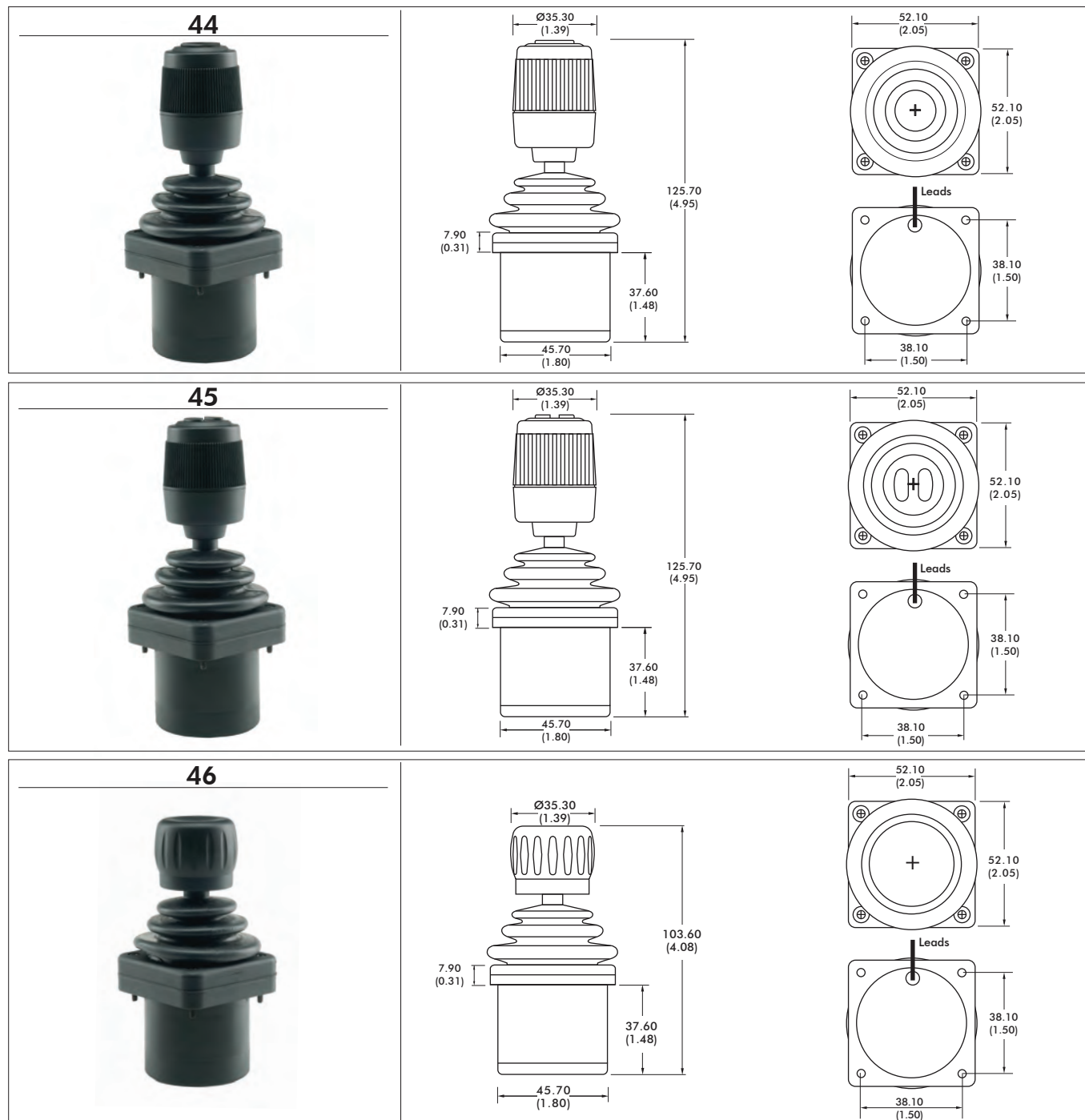

**NOTES:**

1. Dimensions are in mm/(inch)
2. Axes orientation:

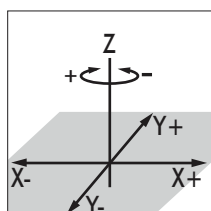

**DEFAULT WIRE COLOR CODE\***

COLOR	FUNCTION	AWG
RED	Vcc or Vdd	
BLACK	Ground	
BLUE	X Axis	28
YELLOW	Y Axis	
GREEN	Z Axis	
WHITE	Switch Common (optional)	
ORANGE	Switch 1 (optional)	22
VIOLET	Switch 2 (optional)	

\* - Starting from the strain relief, the leads are 178mm (7in) long, 3.18mm (0.125in) stripped.



# HT series

## Ruggedized Hall effect joysticks

### DIMENSIONAL DRAWINGS - continued

#### PANEL CUTOUT DIMENSIONS

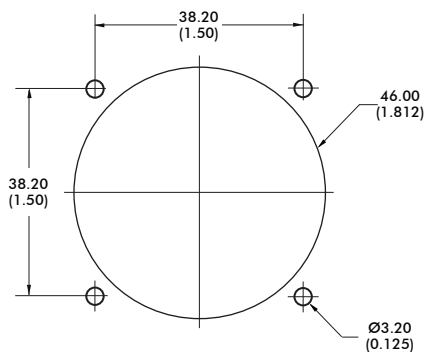

DROP-IN

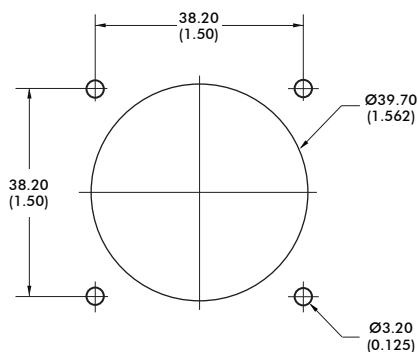

REAR MOUNT

#### CLAMPING RING

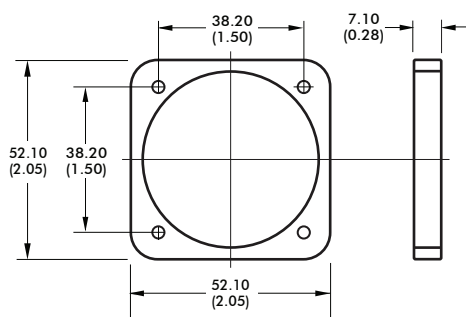

#### MOUNTING OPTIONS

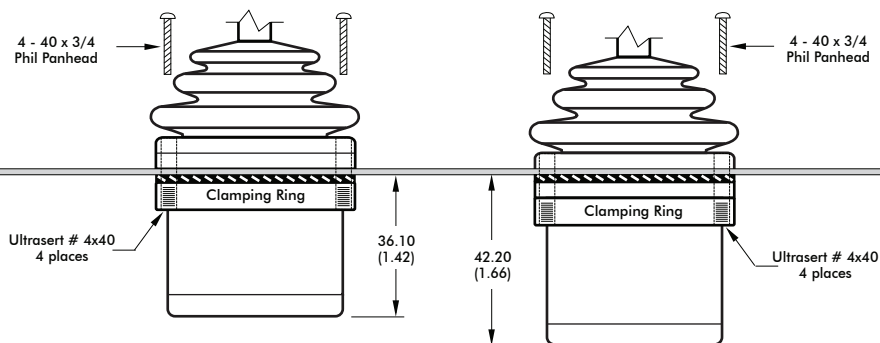

DROP-IN

REAR MOUNT

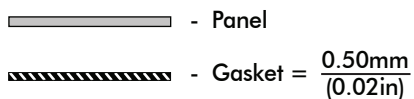

#### NOTES:

- For DROP-IN mounting, the panel thickness can be 1.17mm to 3.17mm (0.046in to 0.125in).
- For REAR MOUNT the maximum panel thickness is 1.6mm (0.063in).
- A panel thickness of 1/16" (1.6mm/0.063in) was considered for all the below-panel depth values.
- The below-panel depth is extended by 7.11 mm (0.28in) with the Joyball, USB, CANbus, Voltage Regulator, Dual Decode, Center Detect, Discrete Board, Analog Deadband, and Dual Sensor options.

# HT series

## Ruggedized Hall effect joysticks

### CONFIGURATION OPTIONS

#### LINEAR OUTPUT OPTIONS

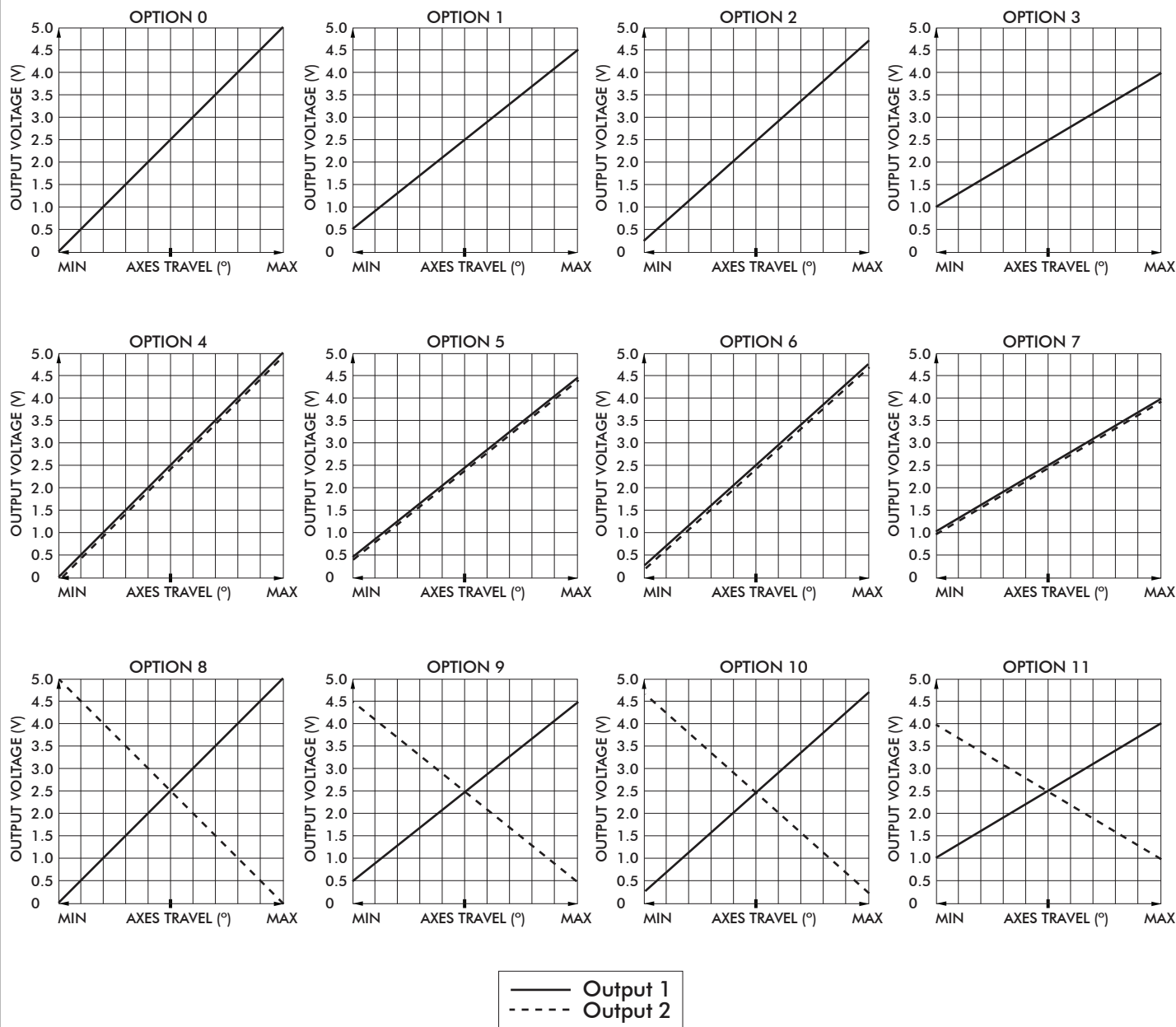

# HT series

## Ruggedized Hall effect joysticks

### CONFIGURATION OPTIONS - continued

#### ADDITIONAL OUTPUT OPTIONS

### CANbus J1939

CH Products HT CANbus joysticks conform to the SAE J1939 serial bus specification used for communications between electronic control units and vehicle components.

#### FEATURES

- CANbus J1939
- Extended I/O extension for up to 2 digital and 3 analog inputs
- Accommodates a 6-40VDC power supply

#### ELECTRICAL SPECIFICATIONS

Supply Power:	-	6 – 40 VDC
Supply Current:	-	15mA min, +5mA per LED, +6mA per axis

#### WIRING SPECIFICATION

Red Wire	-	Supply Power
Black Wire	-	Ground
Green Wire	-	CAN high data
White Wire	-	CAN low data
Blue Wire	-	Identifier Select
Orange Wire	-	Identifier Select

#### CONNECTOR OPTIONS:

- Cable assembly with Deutsch DT04 style plugs
- External I/O harnessing per customer specification

#### CANbus CONFIGURATION CHART

- Contact factory for assistance

BAUD RATE (Check one)		250K	500K	1000K		BLUE WIRE	ORANGE WIRE		
11 BIT IDENTIFIER (CAN2.0A) (Hex)	#1 TX	1	0			G	G		
	RX								
	#2 TX						G		
	RX								
	#3 TX					G			
	RX								
	#4 TX								
	RX								
29 BIT IDENTIFIER (CAN2.0B) (Hex)	#1 TX	3	2	1	0	G	G		
	RX								
	#2 TX						G		
	RX								
	#3 TX					G			
	RX								
	#4 TX								
	RX								
8 BYTE TX DATA FRAME (Binary)	7	6	5	4	3	2	1	0	IDENTIFIER SELECT WIRES
8 BYTE RX DATA FRAME (Binary)									(SUPPLIED IN PIGTAIL)
AXIS DATA TYPE (Check one)	SIGNED CHAR (+/-127)	UNSigned CHAR (0-255)	UNSigned INT (0-1023)	UNSigned INT (0-4095)					G=TIED TO 0V (BLACK WIRE)

# HT series

## Ruggedized Hall effect joysticks

CONFIGURATION OPTIONS - continued

### ADDITIONAL OUTPUT OPTIONS

#### PLUG-AND-PLAY SOLUTIONS:

#### USB

Featuring USB 1.1 HID compliant interface, CH Products' USB joysticks are recognized as standard HID "game controller" devices. Adhering to the HID specification, CH Products' USB joysticks are plug-and-play with most versions of Windows and Linux. Joystick button and axes assignments are dependent upon the controlled application.

#### FEATURES

- USB 1.1 HID compliant "game controller" device
- Easy to install and operate
- Functions determined by controlled application
- Standard Male Type A Connector



USB Male Type A Connector

#### SUPPLIED WIRING

USB: USB Male Type A Connector with overmolded cable  
(Optional ruggedized military connectors are available.)

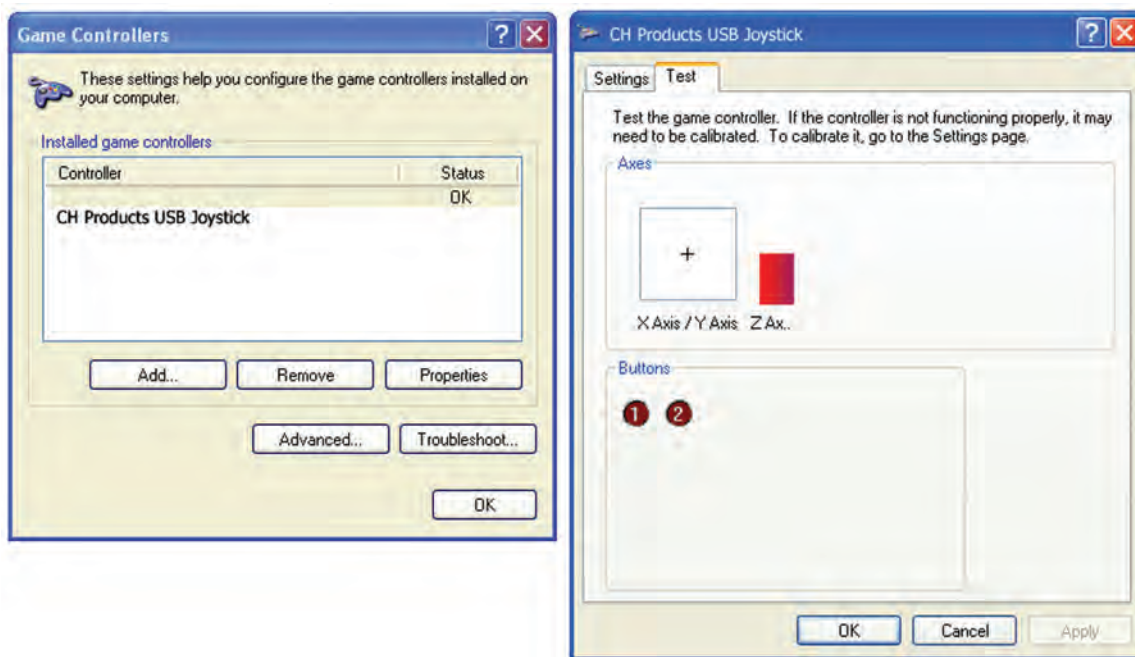

# HT series

## Ruggedized Hall effect joysticks

### CONFIGURATION OPTIONS - continued

#### ADDITIONAL OUTPUT OPTIONS

#### PLUG-AND-PLAY SOLUTIONS:

#### JOYBALL (CURSOR EMULATION)

The Joyball option converts multi-axis joystick output into a mouse, trackball, or cursor control device. The joystick's internal microprocessor converts absolute axis position into a cursor velocity, which is translated as a relative trackball or mouse position. Supported protocols include Sun Microsystems (mouse systems 5vdc serial) and USB.

#### APPLICATIONS

The Joyball option is ideal for vehicle applications subjected to dirt and high vibration which makes operating a traditional cursor control device difficult. The Joyball option is widely used in shipboard and military applications.

#### FEATURES

- HID compliant "pointing device"
- Plug-and-play with USB option
- Ideal for marine GPS and navigation
- Environmental sealing up to IP68

#### SUPPLIED WIRING

USB: USB Male Type A Connector with overmolded cable

SUN: SUN mini-DIN plug with overmolded cable and strain relief

#### I/O COMPLEMENT/ USER SPECIFIED PARAMETERS:

- USB 4 pushbuttons 2 or 3 axes (X, Y, and Z "scroll")
- SUN 2 pushbuttons and 2 axes (X, Y)

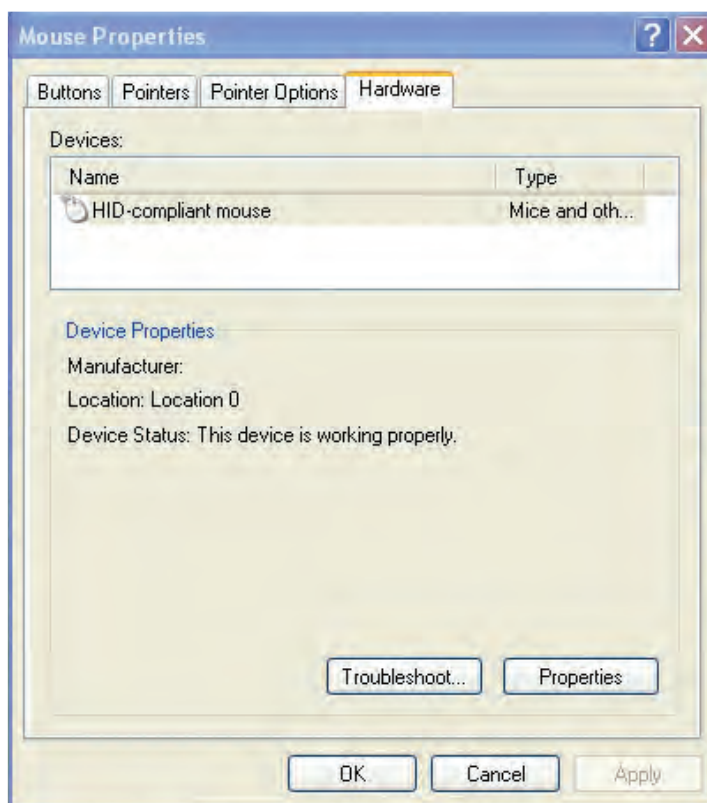



# HT series

## Ruggedized Hall effect joysticks

CONFIGURATION OPTIONS - continued

### ADDITIONAL OUTPUT OPTIONS

#### DUAL DECODE

Dual Decode utilizes a microprocessor to monitor two linear opposite-ramp signals for each joystick axis and provides one proportional (0.5VDC – 4.5VDC) and one logical output accordingly. The dual inversed signals are continuously monitored and a logical signal of 0VDC is provided for over-range (>4.5VDC), under-range (<0.5VDC) and signal tracking (sum of both signals equals 4.5V +/-10%) error. A logical signal of 5.0VDC is provided for a properly functioning joystick deflected from center.

#### APPLICATIONS

Dual Decode provides a center detect function as well as error tracking, making it ideal for high liability, safety critical applications.

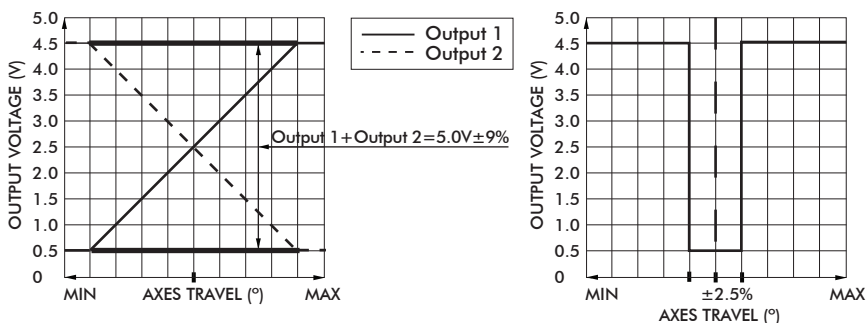

#### ELECTRICAL SPECIFICATIONS

Supply Power	-	4.5VDC to 5.5VDC
Supply Current	-	30mA + 10mA per axis

#### WIRING SPECIFICATION

Red wire	-	Customer power supply 4.5VDC-5.5VDC
Black wire	-	Customer power supply ground
Blue wire	-	X axis output
Yellow wire	-	Y axis output
Green wire	-	Z axis output
Blue/White wire	-	X axis dual decode logic output
Yellow/Black/ wire	-	Y axis dual decode logic output
Green/Black wire	-	Z axis dual decode logic output
White wire	-	Pushbutton common wire
Orange,violet,grey,brown,pink,bl/wt/y/bk,gn/bk,gy/w wire	-	Pushbutton outputs

#### ANALOG DEADBAND

Analog Deadband utilizes an analog circuit to monitor proportional joystick outputs and enhance return to center accuracy over multiple axes. Specified for joysticks with normally ranged outputs of 0vdc – 5vdc at full axis travel, a constant output of 2.5vdc is provided for the joystick's position +/-2.5° from center.

#### APPLICATIONS

Analog Deadband effectively eliminates mechanical return-to-center error, making it ideally suited for safety critical applications susceptible to drift and motion control systems lacking center position trim.

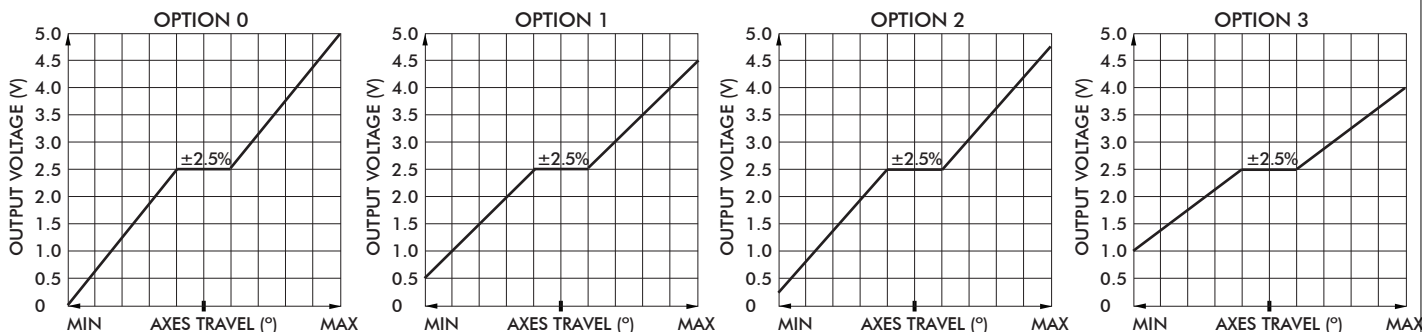

# HT series

## Ruggedized Hall effect joysticks

### CONFIGURATION OPTIONS - continued

#### ADDITIONAL OUTPUT OPTIONS

##### ELECTRICAL SPECIFICATIONS

Supply Power	-	4.5VDC to 5.5VDC
Supply Current	-	10mA per axis

##### WIRING SPECIFICATION

Red wire	-	Customer power supply 4.5-5.5vdc
Black wire	-	Customer power supply ground
Blue wire	-	X axis output
Yellow wire	-	Y axis output
Green wire	-	Z axis output
White wire	-	Pushbutton common wire
Orange,violet,gray,brown,pink,bl/wt/y/bk,gn/bk,gy/w wire	-	Pushbutton outputs

## CENTER DETECT

Center Detect utilizes a microprocessor to monitor joystick output and provides both logic and proportional signals for enhanced operator safety. Specified for a joystick normally ranged 0.5VDC to 4.5VDC, the microprocessor continuously monitors the proportional output and provides HI logic signal (5.0VDC) when moved off center and an LO logical signal (0VDC) for an over-range (>4.5VDC) or under-range (<0.5VDC).

### APPLICATIONS

Center Detect is ideal for safety critical applications including master relay control "MRC" for a motion control systems or as a brake release for an overhauling load.

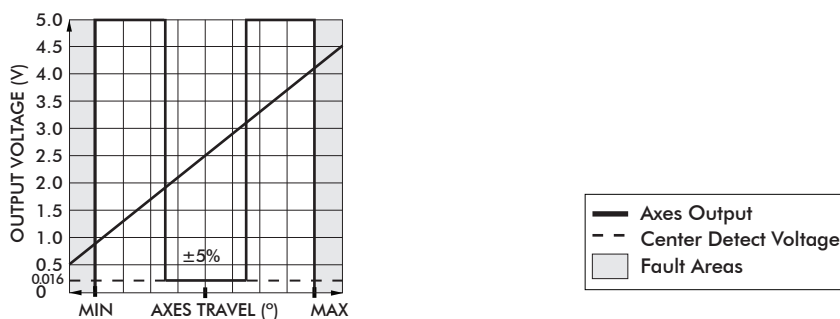

##### ELECTRICAL SPECIFICATIONS

Supply Power	-	4.5V to 5.5V
Supply Current	-	30mA + 10mA per axis

##### WIRING SPECIFICATION

Red Wire	-	Power supply 4.5 - 5.5VDC
Black Wire	-	Ground
Blue Wire	-	X axis output
Yellow Wire	-	Y axis output
Green Wire	-	Z axis output
Blue/White Wire	-	X axis center detect logic output
Yellow/Black Wire	-	Y axis center detect logic output
Green/Black Wire	-	Z axis center detect logic output
White Wire	-	Pushbutton common wire
Orange,violet,gray,brown,pink,bl/wt/y/bk,gn/bk,gy/w wire	-	Pushbutton outputs

# HT series

## Rugged finger positioning Hall effect joysticks

### CONFIGURATION OPTIONS - continued

#### ADDITIONAL OUTPUT OPTIONS

### DISCRETE OUTPUT

Discrete Output is a microprocessor based option that provides up to six hi voltage/hi current, on/off outputs as well as proportional signals. Featuring a microcontroller, an a/d converter, and four to eight optically isolated solid state switches, the Discrete Output provides an electronic "switch stick" function. Switch combinations and firing angles are programmed to the application's requirement.

#### APPLICATIONS

The Discrete Output option is designed for small motor, reversing starters or hydraulic solenoid actuations.

#### DC SPECIFICATIONS

Supply Voltage Operating	-	5.0- 40VDC input power
Supply Current	-	30mA + 10mA per Hall sensor
Sourcing Outputs	-	70V AC/DC @ 1.6A max.
Sinking Outputs	-	70V AC/DC @ 3.6A max.
Discrete Output Max	-	60VDC/AC, 3.2A per discrete output

#### WIRING

Red Wire	-	Customer power supply 5 - 40VDC
Black Wire	-	Customer power supply ground
Blue Wire	-	X axis output
Yellow Wire	-	Y axis output
Green Wire	-	Z axis output
Blue/White Wire	-	X axis discrete output
Yellow/Black Wire	-	Y axis discrete output
Green/Black Wire	-	Z axis discrete output
White Wire	-	Pushbutton common wire
Orange,violet,gray,brown,pink,bl/wt,y/bk,gn/bk,gy/w wire	-	Pushbutton outputs

#### I/O COMPLEMENT AND USER SPECIFIED PARAMETERS:

Up to three axis and six discrete outputs sourcing or sinking discrete outputs.

#### DISCRETE OUTPUT CONFIGURATION FORM:

Discrete Output	Sourcing	Sinking	AC	DC
Xfwd				
Xrev				
Yfwd				
Yrev				
Zfwd				
Zrev				

#### SAMPLE OF COMPLETED FORM:

(Please enter required choices for each applicable axis and return form to factory.)

Discrete Output	Sourcing	Sinking	AC	DC
Xfwd		X		X
Xrev		X		X
Yfwd	X			X
Yrev	X			X
Zfwd		X		X
Zrev		X		X

# HT series

## Ruggedized Hall effect joysticks

### CONFIGURATION OPTIONS - continued

#### ADDITIONAL OUTPUT OPTIONS

#### VOLTAGE REGULATOR

The Voltage Regulator is a multi-wired analog option used to mate to a variety of industrial control voltages. The Voltage Regulator may be used when the supply or output voltage is greater than 5V or when bipolar output is required.

User Specified Supply Voltage:

- 5 VDC
- 10 VDC
- 12 VDC
- 24 – 30 VDC
- Custom supply options available.

User Specified Output Voltage:

- 0-5 VDC
- 0-10 VDC
- +/-5 VDC
- +/-10 VDC
- Custom outputs available.

#### ELECTRICAL SPECIFICATIONS

Supply Power	-	5VDC to 30VDC
Supply Current	-	90mA max

#### WIRING SPECIFICATION

Red wire	-	Supply power 5-30VDC
Black wire	-	Ground
Blue wire	-	X axis output
Yellow wire	-	Y axis output
Green wire	-	Z axis output
White wire	-	Pushbutton common wire
Orange,violet,gray,brown,pink,bl/wt/y/bk,gn/bk,gy/w wire	-	Pushbutton outputs





# BF series

## Paddle controllers



The BF Series Paddle is the very latest generation in high precision contactless controls. It combines the features of a contactless single axis joystick and a switch in one control. Long trouble-free life is assured with the latest Hall effect technology, providing a range of analog, switched or custom PWM output options. The all-new design with its innovative mechanism and ergonomic styling is specifically designed for robustness, strength and performance.



### KEY FEATURES

- Hall effect joystick and switch function
- Sculpted ergonomic design
- Next generation Hall effect technology
- 5V operation - dual redundant outputs as standard
- Two lever height variants
- Industry standard connector
- IP67 sealed
- Sprung and detent lever options
- Available with color-coded inserts
- EMC & Magnetically shielded - analog or PWM outputs
- Effectively zero below panel depth
- End stackable mounting





# BF series

## Paddle controllers

### OPTION SELECTION

<b>PADDLE</b>	<b>GAIN</b>	<b>INSERT COLOR</b>	<b>MODIFIER</b>
<b>BF</b> 74mm (2.91in) above the panel  <b>BD</b> 50mm (1.97in) above the panel	<b>10</b> +/-10% x V  <b>25</b> +/-25% x V  <b>30</b> +/-30% x V  <b>40</b> +/-40% x V  <b>50</b> +/-50% x V	<b>BK</b> Black  <b>RE</b> Red  <b>BL</b> Blue  <b>YE</b> Yellow  <b>GR</b> Green	<b>00</b> None
<b>CONFIGURATION</b>	<b>LEVER OPERATION</b>	<b>SWITCHING POINTS</b>	
<b>1</b> Standard Dual Outputs  <b>2</b> Inverse Dual Outputs  <b>3</b> PWM	<b>A01</b> Sprung to Center  <b>D01</b> Center Detent  <b>D02</b> 12.5 Degree Detents  <b>D03</b> 12.5 & 25 Degree Detents  <b>D04</b> 25 Degree Detents  <b>SD1</b> Sprung to Center with D1  <b>SD2</b> Sprung to Center with D2  <b>SD3</b> Sprung to Center with D3  <b>SD4</b> Sprung to Center with D4	<b>00</b> No Switches  <b>05</b> +/- 5 Degrees  <b>12</b> +/- 12.5 Degrees  <b>25</b> +/- 25 Degrees	

### LEVER OPERATION

#### DETENT OPTIONS

D01 = CENTER DETENT

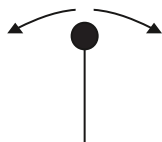

D02 = +/-12.5 DEGREES

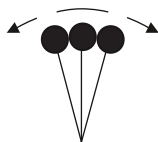

D03 = +/- 12.5 & 25 DEGREES

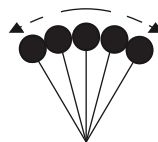

D04 = +/-25 DEGREES

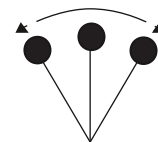

#### SPRUNG TO CENTER WITH DETENT OPTIONS

SD1 = CENTER DETENT

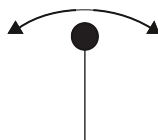

SD2 = +/-12.5 DEGREES

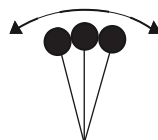

SD3 = +/- 12.5 & 25 DEGREES

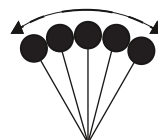

SD4 = +/- 25 DEGREES

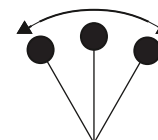

# BF series

## Paddle controllers

### SPECIFICATIONS

MECHANICAL	
Materials Employed	- Polyetherimide, Polycarbonate, Stainless Steel
Weight	- 50g
Mechanical Operating Angle	- +/- 25 Degrees
Max Load to Mechanism	- Vertical: IK08 (BSEN62262:2002) Horizontal: 75N (16.86lbf)

ELECTRICAL	
Gain (Output Voltage Span)	- +/-10% x V to +/-50% x V
Output at Center	- V/2 +/- (5% x Gain)
Power Supply	- 5V +/-0.5V Transient free
Switch Outputs	- Open Drain, pulled high within control via 1K5 to 5V, and smoothed to 0V with 100nF
Sensor Type	- Hall effect
Current Consumption	- <20mA
Loads	- Minimum 10K, preferred 100K+

ENVIRONMENTAL	
Storage	- -40°C to 70°C (-40°F to 158°F)
Operating Temperature	- -25°C to 70°C (-13°F to 158°F)
Seal Above Panel	- IP67 (Gasket fitted as standard)
EMC Emissions	- Complies with EN 61000-6-3:2001 CISPR 22:2005 Class B 30MHz - 11GHz
Life Cycles	- 5 million cycles sprung version only. Detents rated to 2 million cycles
ESD	- Complies with EN61000-4-2 (extended) +/-8KV (20 contacts) & +/-15KV (20 air discharges)
EMC Immunity	- 100V/m, 80MHz-2.7GHz, 1KHz 80% sine wave modulation, EN 61000-4-3 (extended)
Vibration	- 100Hz - 200Hz @ 0.13g <sup>2</sup> /Hz, total 3.6gRMS (1 Hour in each of the three mutually perpendicular axes)

All parameters shown are based on a standard configuration and are provided for guidance only. Please refer to Apem for assistance on how to achieve the best performance from your chosen configuration.



# BF series

## Paddle controllers

### DIMENSIONAL DRAWINGS

#### GENERAL DIMENSIONS

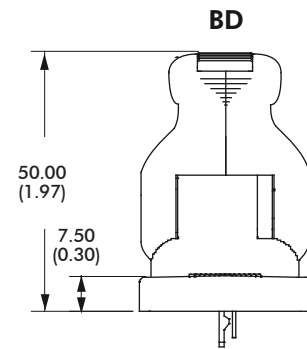
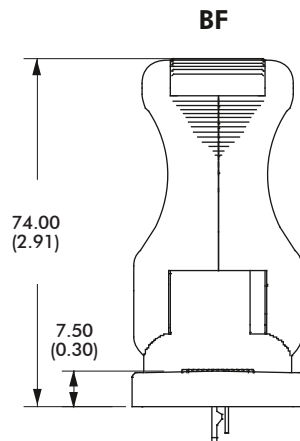
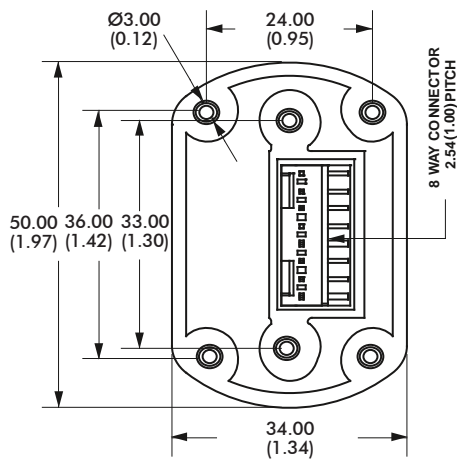

#### DROP IN MOUNTING - PANEL CUT-OUT & MOUNTING INSTALLATION

The Paddle may be mounted with two different hole patterns:

- Two screws - in line on the Y axis (shown as yellow screws)
- Four screws - one in each corner (shown as silver screws)

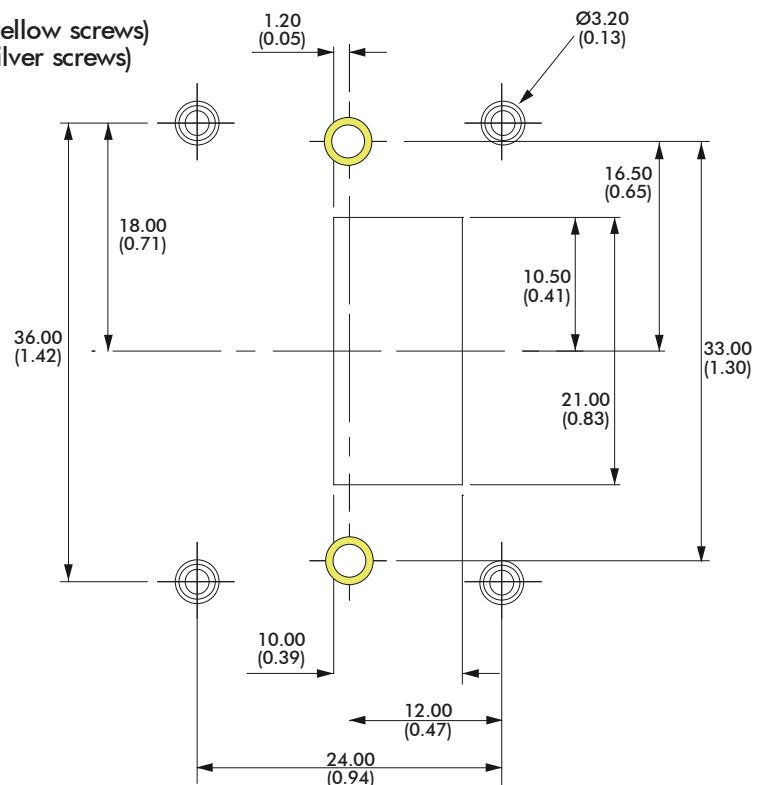

The Paddle is fitted with M3 bushes in all six positions, as standard.  
Fasteners are not supplied as standard. The appropriate length of fastener is dependent on panel thickness.

NOTE: All dimensions in mm/(inch).

# BF series

## Paddle controllers

### MECHANICAL & CONNECTION INFORMATION

#### MECHANISM

The brand new mechanism design has been developed for strength and long life while retaining a superb feel.

#### SPRUNG TO CENTER

The lever springs back to the center position when released.

#### DETENT POSITIONS

The lever 'clicks' into a number of preset positions. The internal switches can be configured to trigger at two of these points

#### DETENT POSITIONS WITH SPRUNG TO CENTER

The lever 'clicks' into a number of preset positions and springs back to its center position when released.

#### CONNECTIONS

The Paddle is fitted, as standard, with an industry standard 2.54mm pitch 8 way connector.

### CONNECTIONS

Paddles are supplied with an eight way connector as standard.

- PIN 1: 5V
- PIN 2: Switch 1(+)
- PIN 3: 0V
- PIN 4: Analog/PWM output 1
- PIN 5: Analog/PWM output 2
- PIN 6: 0V
- PIN 7: Switch 2 (-)
- PIN 8: 5V

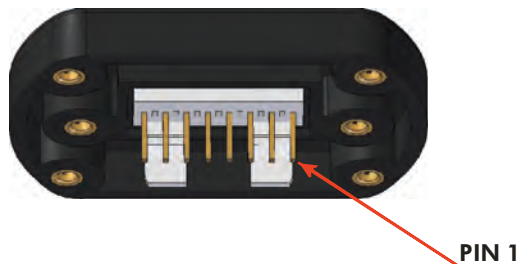

### BF SERIES OUTPUT CHARACTERISTICS - 40% GAIN DUAL INVERSE OUTPUTS

Switches at 12.5 Degrees

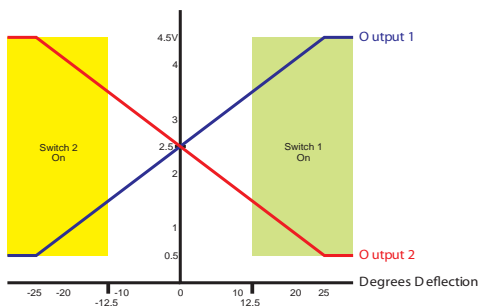

Switches at 25 Degrees

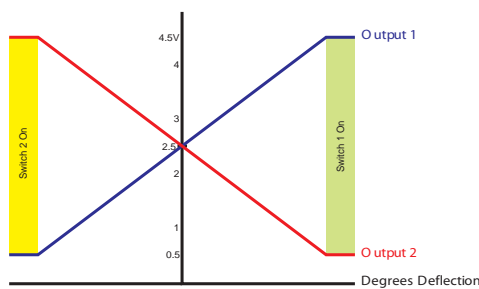

Equivalent circuit for the switch output

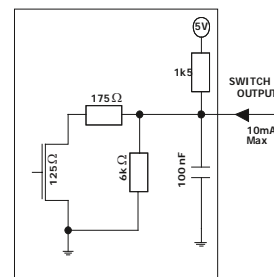

### 40% GAIN DUAL OUTPUTS

Switches at 12.5 Degrees

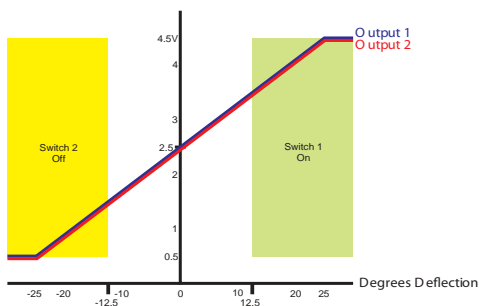

Switches at 25 Degrees

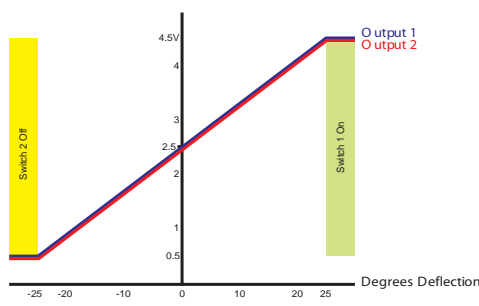

Note: When Dual Output (non-inverted) option is selected the polarity of Switch 2 is inverted

# BF series

## Paddle controllers

### CONFIGURATION OPTIONS

#### OUTPUT OPTIONS

The BF Series Paddle is configured as two "electrical" controls in one mechanical package. The Paddle operates from 5V and provides two proportional outputs. The second output is accurate to the first within +/-3% of the power supply. The power supply for the secondary output is also completely independent. Customers may choose their preference of voltage outputs (gains).

The secondary output can be of the same or inverse polarity to the primary wiper. For example, with a secondary inverse output, the first and second outputs can be summed and compared to zero to verify that the joystick is operating correctly. Paddles having two identical outputs of the same polarity may be used to drive two identical dual redundant circuits.

There are also two Hall effect switches that trigger at pre-determined lever positions.

The BF Series Paddle may be specified with a variety of PWM output options. For more details on available PWM options please refer to Apem.

#### ADDITIONAL OUTPUT INFORMATION

##### SELECTABLE SWITCHING POINTS

The Paddle incorporates two Hall effect switches. The angle of the lever at the switch trigger point can be selected when ordering.

If no switches are specified then the output on pins 2 and 7 will be unused.

The outputs are configured as 'open drain' type with a 1K5 pull up resistor to 5V.

##### GAIN OPTIONS

The voltage output on the wiper, at full scale deflection is determined by the gain. The gain is expressed as a percentage of the voltage supplied. Therefore (assuming a 5V supply) a Paddle specified with +/- 25% gain would yield 1.25V at South, 2.5V at center and 3.75V at North. A range of gain options are available as standard. All controls are supplied pre-set and no further calibration is needed throughout the lifetime of operation.

##### OUTPUT IMPEDANCE

The voltage outputs at center and at each end of travel are specified across an infinite load, with no current flowing. The output impedance specified in the electrical specification should be taken into account when designing a system. Load resistance of less than 10K Ohms is not recommended.

##### HANDLE OPTIONS

The BF Series offers two standard handle options. The taller (74mm) handle provides the most ergonomic solution while the shorter (50mm) is best suited to hand held applications where a minimized height is preferred. The taller lever is supplied with the top insert prefitted, however the shorter lever may be specified with no insert fitted and the snap in inserts supplied loose for ease of customer integration.



# BF series

## Paddle controllers

### APPLICATION DETAILS

#### LINEAR OUTPUT OPTIONS

##### DUAL OUTPUT - CONFIGURATION 3

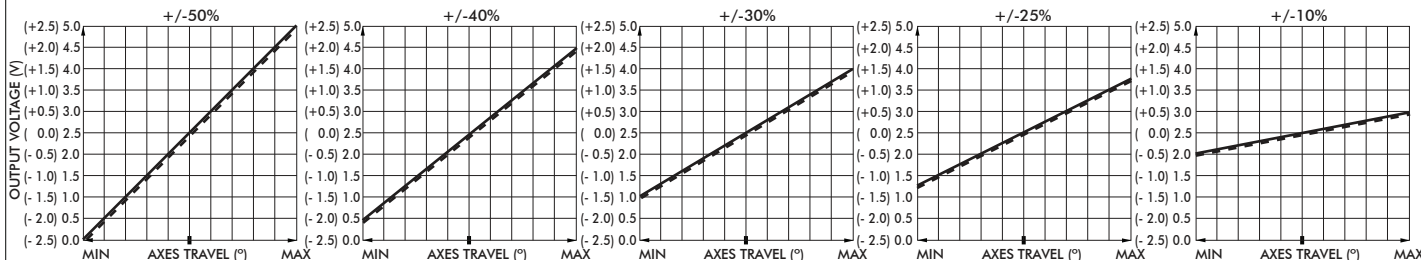

##### DUAL OUTPUT - CONFIGURATION 4

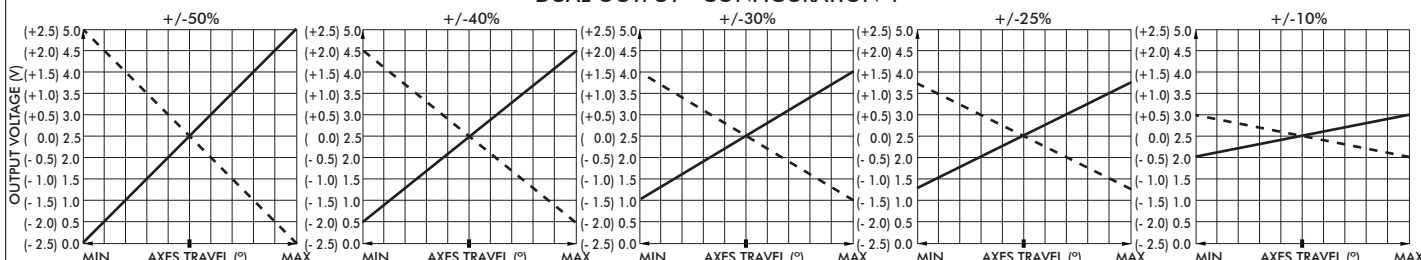

#### POWER SUPPLY

The BF Series is designed to be powered by a regulated 5V +/- 0.5V power supply. The outputs are ratiometric, making a stable, noise free, power supply essential. The power supply to the joystick should be carefully regulated to be within tolerance. Should the power supply change outside of the specified tolerances, permanent damage may occur.

#### MAGNETIC IMMUNITY AND SYSTEM DESIGN

The BF Series incorporates internal magnetic screening to minimize the effect of external magnetic fields. Mounting or operating the Paddle close to strong magnetic fields is not recommended. System designers should follow best practice when incorporating the BF Series Paddle into their products. Care should be taken to decouple the power supply properly and to employ adequate EMC shielding.

#### MOUNTING

When mounting the Paddle, care should be taken to site it in a position that does not make it vulnerable to damage when in use. If the Paddle is intended for use in a handheld enclosure then care must be taken to protect the Paddle from damage caused by dropping. Basic precautions such as mounting it at the lightest end of the enclosure so it doesn't hit the ground first or by protecting it with a guard should always be implemented for long term reliability. The body of the Paddle, on the underside of the panel, must not be subject to water spray, excessive humidity or dust.





# 1000 series

Compact switch joysticks



The 1000 Series is a versatile range of low cost switch joysticks and is ideal for light to medium duty environments where proportional control is not a necessity. Configurable with either single or double pole switching, the 1000 Series can also be specified as screw or bush mounted.

There are two construction options, based on the use of either V3 or V4 switches. V4 switches may be specified with 6A or 10A operation, yielding a smaller joystick than the construction employed for V3 switches which yields up to 16A operation.



## KEY FEATURES

- Compact size
- Robust construction
- Single or dual axes
- Single or double pole
- Gold contacts
- Bushing or screw mount
- V4 switches
- V3 switches
- Alternative handle selection including pushbutton handles



# 1000 series

## Compact switch joysticks

### OPTION SELECTION

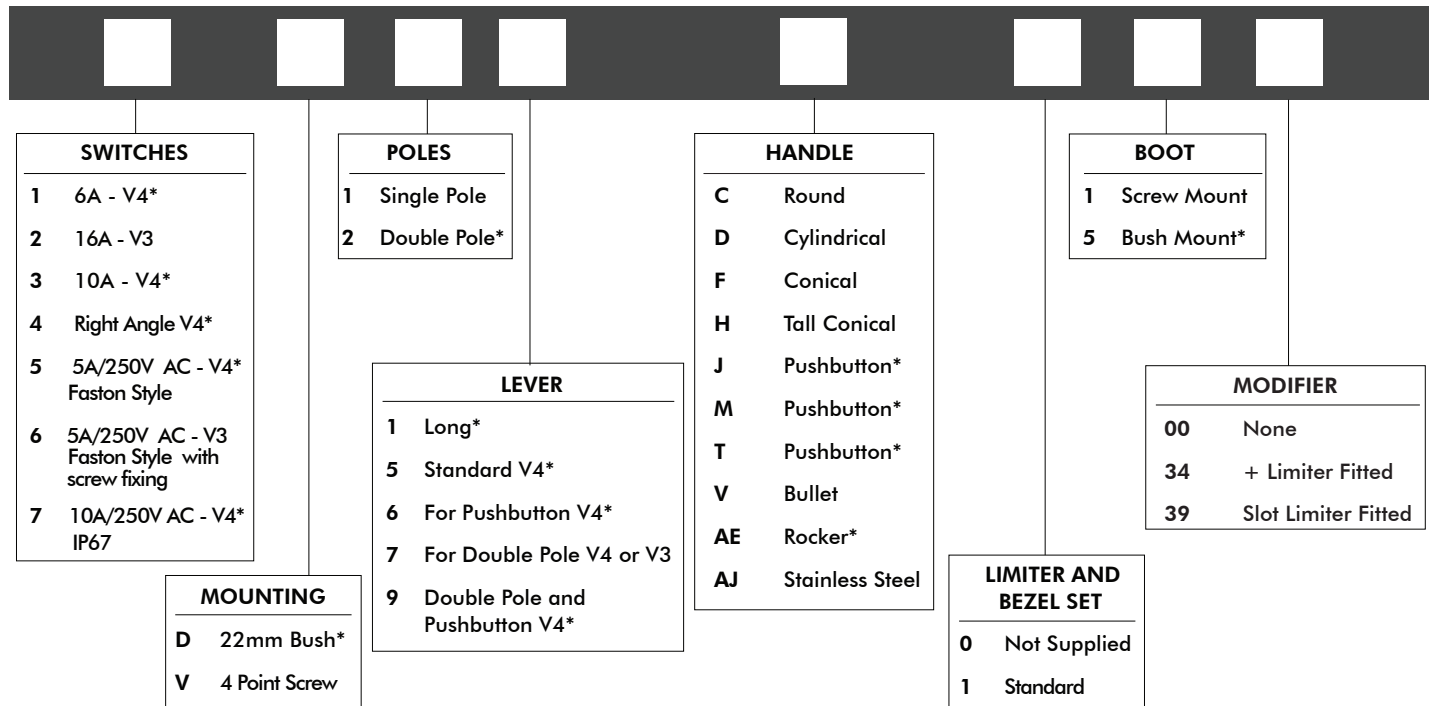

\* Unavailable with V3 construction.

### SPECIFICATIONS

MECHANICAL		
Mechanical Life	-	>5 Million Operations
Lever Travel	-	24° (12° from center)
Lever Material	-	Stainless Steel or Brass
Mass/weight	-	40g
Body Material	-	Mineral Filled Nylon-6
Handle Material	-	See Handles Page
Boot Material	-	Neoprene
Mounting - Screw	-	4 x M2.5 Stainless (Slotted)
Mounting - Bush	-	Single Point 22mm Diameter

ELECTRICAL		
Number of Switches	-	2, 4, or 8
Nominal Current	-	6A, 10A, or 16A
Maximum Voltage	-	250V AC
Contacts #1 6A - V4	-	Gold
Contacts #2 10A - V4	-	Silver
Contacts #3 16A - V3	-	Silver
Contacts #4 Right Angle	-	Silver
Contacts #5 Faston Style - V4	-	Silver
Contacts #6 Faston Style - V3	-	Silver
Contacts #7	-	Silver
Switch Contacts	-	Changeover
Contact Life	-	Load Dependent
Pushbutton Cable	-	Blue

ENVIRONMENTAL		
Temperature Range	-	-20°C to 50°C <sup>3</sup>
Above Panel Seal (IP)	-	To IP67 <sup>1</sup>

#### NOTES

- All values are nominal
- 1. Excludes some handle options.
- 2. Exact specifications may be subject to configuration. Contact Technical Support for the performance of your specific configuration.
- 3. Temperature specification may be subject to the chosen switch option. Please refer to factory.

# 1000 series

## Compact switch joysticks

### DIMENSIONAL DRAWINGS - HANDLES

MATERIAL	Phenolic	Aluminum	Nylon	Stainless Steel
FINISH	Gloss	Anodized	Matt	Natural
STANDARD COLOR	Black	Black	Black	Stainless Steel
OTHER COLORS	Not Available	Not Available	Upon Request	Not Available
NOTES:	Supplied Loose			

MATERIAL	ABS	Aluminum	Stainless Steel	ABS	Aluminum	Stainless Steel
FINISH	Matt	Anodized	Polished	Gloss	Anodized	Polished
STANDARD COLOR	Black	Black	Stainless	Black	Black	Stainless Steel
OTHER COLORS	Upon Request	Not Available	Not Available	Upon Request	Not Available	Not Available
NOTES:	Uses APEM IS Switch	Uses APEM IS Switch	Uses APEM IS Switch		Uses APEM TR Switch	

**NOTES:**

1. Dimensions are in mm/(inch)
2. Pushbutton (J, M, T) and rocker switches (AE) are for bushmount configurations only. Dimensions are shown below.
3. Handle is supplied loose because it is larger than panel cutout. The handle should be press fitted to the joystick, once the joystick is installed in the panel

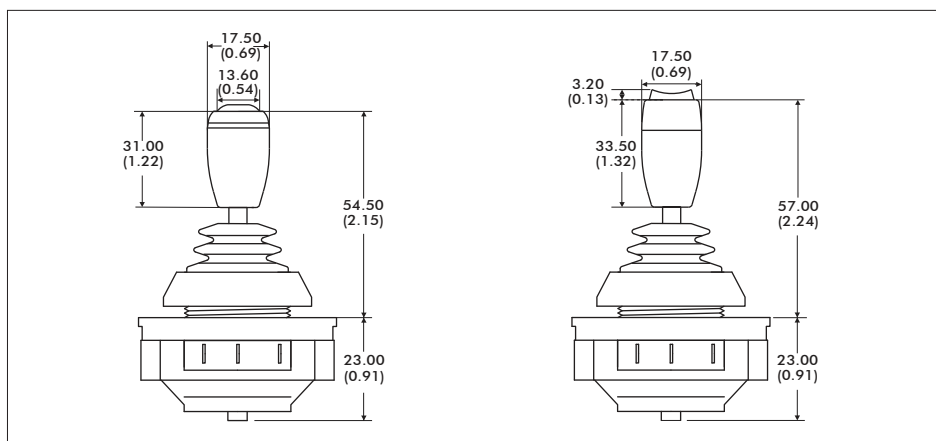



# 1000 series

## Compact switch joysticks

### DIMENSIONAL DRAWINGS - continued

**V4 BUSH MOUNT**

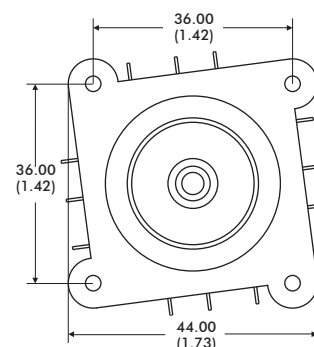
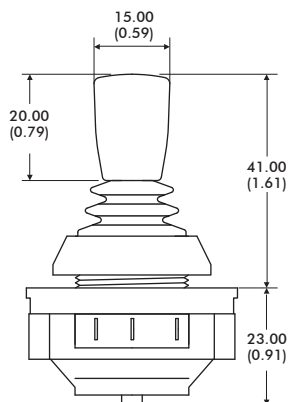

**V4 SCREW MOUNT**

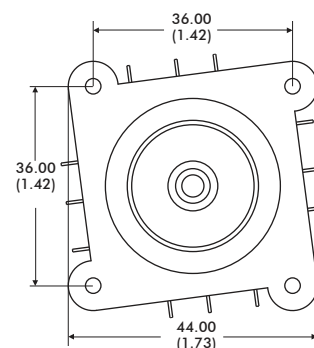
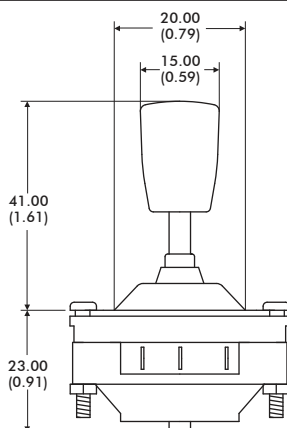

**V4 SCREW MOUNT DOUBLE POLE**

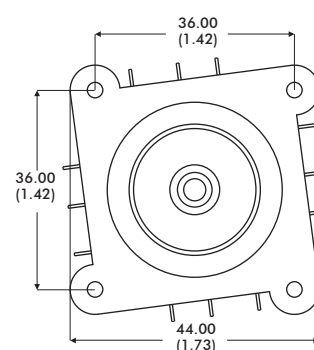
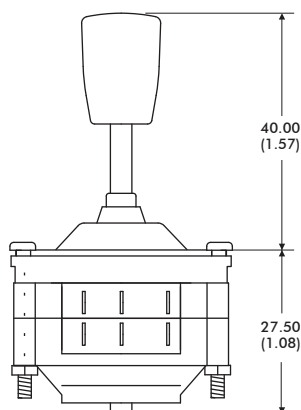

**V3 SCREW MOUNT**

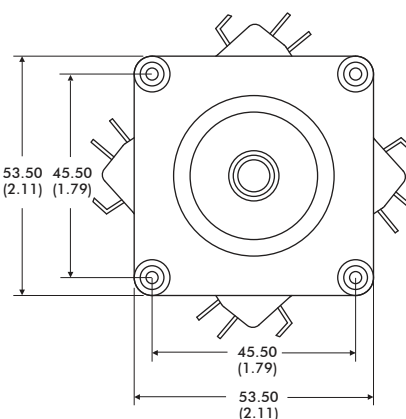
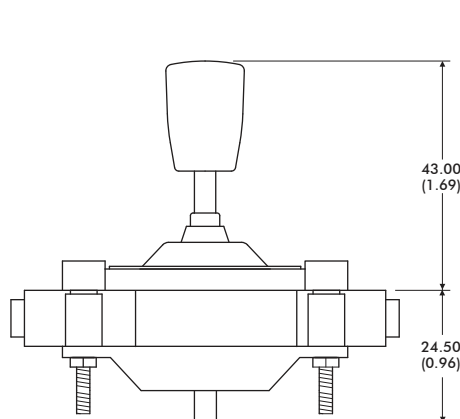





# 1000 series

## Compact switch joysticks

### DIMENSIONAL DRAWINGS - continued

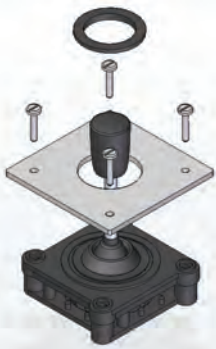
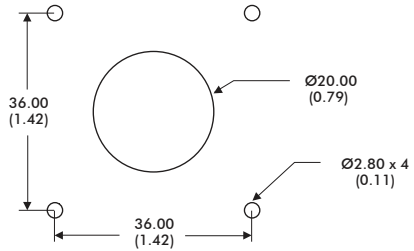
#### MOUNTING CUTOUT DIMENSIONS AND INSTALLATION

<p><b>V4 SCREW MOUNT</b></p> 	<p><b>NOTE:</b>                  The joystick is mounted from beneath the panel using the 4 x M2.5 machine screws, supplied with the joystick.                  Supplied as standard with the joystick is a round bezel which may be fitted (according to customer preference) to finish the front face of the panel. Fitting the bezel is optional, and is not necessary if the panel cut-out finishes the panel. If fitting the bezel is selected then the panel cut out should be toleranced such that the bezel is an interference fit. Additionally bonding the bezel is recommended.</p> 
--	--

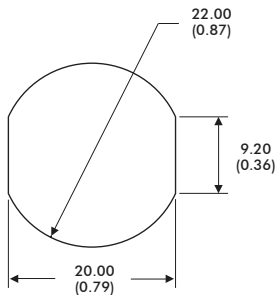
<p><b>V4 BUSH MOUNT</b></p> 	<p><b>NOTE:</b>                  The joystick is mounted from beneath the panel. Supplied as standard with all bush mount joysticks is an adhesive P.V.C. sealing gasket. This should be fitted between the joystick and the panel, in applications where a good seal is needed.</p> 
--	---

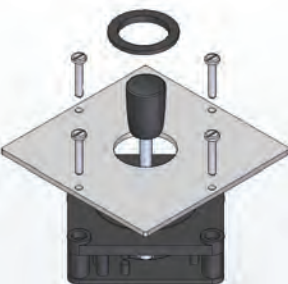
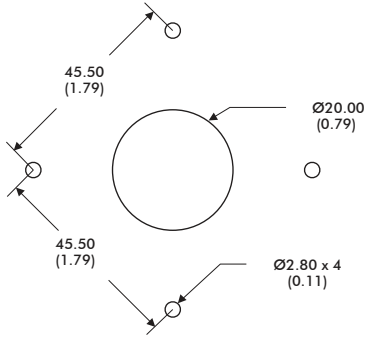
<p><b>V3 SCREW MOUNT</b></p> 	<p><b>NOTE:</b>                  The joystick is mounted from beneath the panel using the 4 x M2.5 machine screws, supplied with the joystick. Supplied as standard with the joystick is a round bezel which may be fitted (according to customer preference) to finish the front face of the panel. Fitting the bezel is optional, and is not necessary if the panel cut-out finishes the panel. If fitting the bezel is selected then the panel cut out should be toleranced such that the bezel is an interference fit. Additionally bonding the bezel is recommended.</p> 
---	---

#### LIMITERS AND BEZEL SET

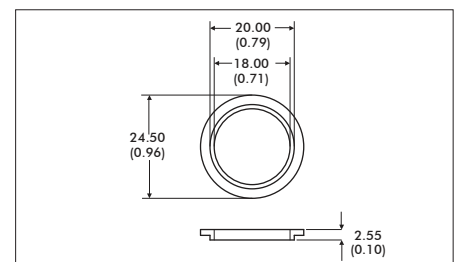
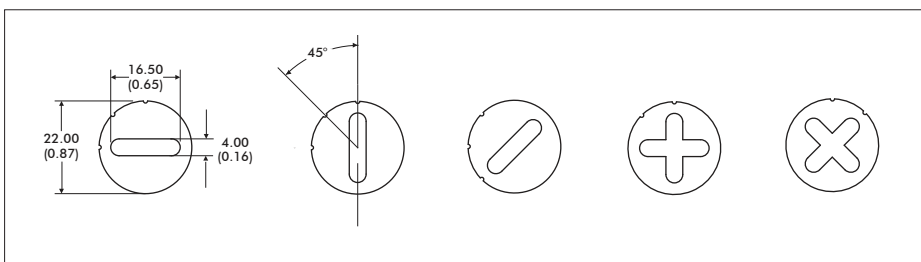

**NOTES:**

1. Dimensions are in mm/(inch)

# 1000 series

## Compact switch joysticks

### CONFIGURATION OPTIONS

#### SWITCHES

Seven switch options are specified as standard. All are configured with change-over contacts, allowing the user flexibility of connection.

Option 1 - V4 - 6A/240V AC should be specified where the joystick will be switching smaller current levels. These switches are supplied with gold flash terminals to ensure reliable switching at very low current levels.

Option 2 - V3 - 16A/240V AC should be specified where the joystick will be switching up to 16A.

Option 3 - V4 - 10A/240V AC should be specified where the joystick may be switching up to 10A.

Option 4 - V4 - 5A/250V AC with right angle terminals, should be specified for PCB mounting or simpler termination.

Option 5 - V5 - 5A/250V AC with 2.8mm Faston style terminals.

Option 6 - V3 - 16A/250V AC with long terminals and screw fixing

Option 7 - V4 - 10A/250V AC sealed to IP67

Note: The construction of the joystick employing V3 switches is not available with as many configuration options.

Life and reliability of the switches is heavily determined by the type of application and parameters such as load. Contact the factory for further advice about the expected switch performance under differing loads or DC supplies.

#### MECHANICAL OPERATION

All 1000 Series are supplied with an open square gate. As a standard option the joystick may be supplied with an additional plastic limiter set, that allows the customer to retro-fit limiters to reduce the travel to single axis(-), cross (+) or diagonal (X) operation. For harsh environments metal limiters are also available.

Joysticks are supplied as standard without a cable harness, allowing the user flexibility of connection. Alternatively the joystick may be factory configured with fitted limiters or cable harnesses, upon customer request.

#### SEALING

Two boot options are offered as standard to provide an above-panel seal. When specifying a bush mount joystick select boot option 5 which yields an IP65 seal. Alternatively boot option 1 should be selected for 4 point screw mount joysticks which yields an IP67 seal. As standard, an adhesive P.V.C sealing gasket is supplied with all bush mount joysticks, to ensure a good seal between the joystick body and the panel. The sealing standards quoted are panel seals. It is assumed that the below panel area will be sealed. For applications where below panel seal can not be assured, switch option 7 should be selected.

#### DOUBLE POLE OPERATION

The construction of the joystick is designed such that both switches nominally trigger simultaneously. Such simultaneous triggering is subject to a +/-2 degree tolerance (between switches) owing to the mechanical tolerances and hysteresis of each switch.

#### MOUNTING

The 1000 Series is available in two mounting options, four point screw mount or bush mount. The V4 screw mount option is supplied with M2.5 x 20mm screws, whereas the larger construction of V3 screw mount joystick is supplied with M2.5 x 25mm screws. All screws supplied are slotted, pan head machine screws, although longer pan head screws, or countersunk heads are also available upon request.

#### LEVERS

Lever option 5 provides for a low profile above the panel (41mm/1.61inch), this option is very popular for those applications requiring a compact, stubby design. Lever option 1 is an additional 5mm/0.20inch taller. Lever option 6 should be specified for a push button handle, and lever option 7 is designed for V4 double-pole, or V3 constructions. Lever Option 9 is for double-pole and pushbutton joysticks. Additional custom levers are available upon request.

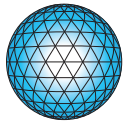

# APEM

## 8000 series

Ruggedized switch joysticks



The 8000 Series is a family of rugged switch joysticks. Based on the proven mechanics of the 9000 Series, the 8000 Series utilizes high quality microswitches to provide a range of possible outputs, including the option of progressive switching on a single axis for dual speed control.



### KEY FEATURES

- One or two axes
- Optional center detect microswitch
- Wide range of handle options
- Up to 1AMP operation
- Gold plated contacts
- Single step or progressive switching



# 8000 series

## Ruggedized switch joysticks

### OPTION SELECTION

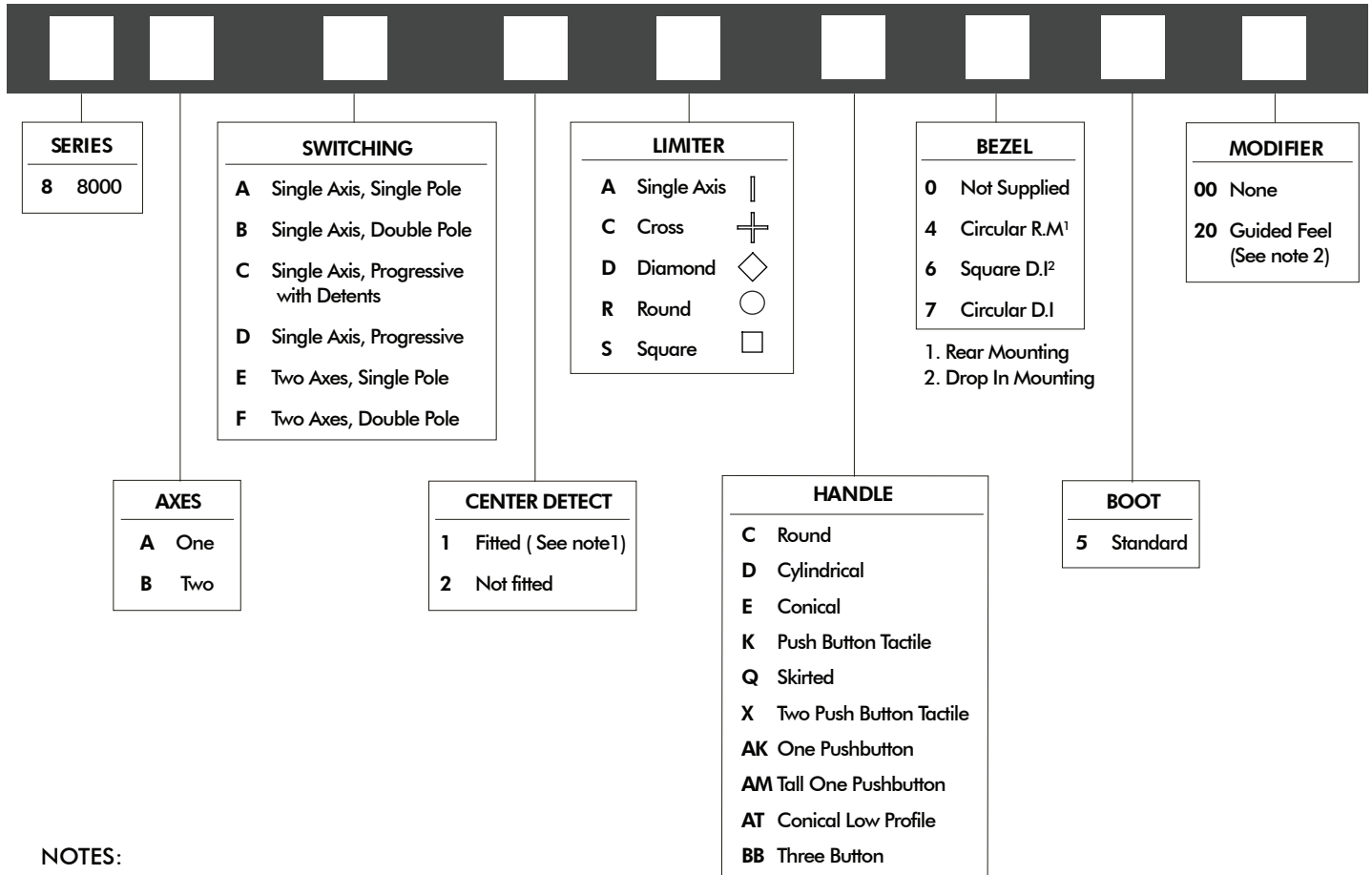

**NOTES:**

1. The additional center detect switch is not available on joysticks with progressive switching.
  2. Guided feel is only available on two axes joysticks.
- Further non-standard options including custom handles, special limiters and detents are available. Please refer to the factory.
3. Only a square limiter will allow sufficient travel in a diagonal direction to activate both speed and steer switches.

**BEZEL OPTIONS**

For drop in mounting, please specify bezel option 6 or 7. For sub-panel mounting, no bezel is necessary, unless the boot is required to seal to the front face of the panel in which case option 4 should be specified. Bezels 6 & 7 clamp the boot and top face of the joystick body to the panel when bezel 4 clamp only the boot.

**SPRINGING**

As standard 8000 Series are offered sprung to center. The standard spring force requires 1.3N (nominally) to off-center the joystick. The 8000 Series may be specified with a lighter spring (1N), or a stronger spring (1.6N)  
 Note: Forces quoted are subject to exact joystick configuration and are provided as a guide only.

### SPECIFICATIONS

Mechanical Life Cycles	: > 1 Million Mechanical Operations	Maximum Voltage	: 125 VAC
Current Rating	: To 1A	Switch Contacts	: Gold Plated
Weight	: 90 grams (0.20lbs)	Above Panel Seal	: IP65
Operating Deflection	: +/-18°	Body Material	: Glass Reinforced ABS
Shaft Diameter	: 5 mm (0.20in)	Gimbal Pivot	: Acetal & Hardened Steel
Shaft Material	: Stainless Steel	Other Materials	: Brass, Acetal, Nylon
Boot	: Neoprene	Temperature Range	: -25°C to 80°C (-13°F to 76°F)

1. Life and reliability of the switches is heavily determined by the type of application and parameters such as load. The Technical Support team will provide further advice about the expected switch performance under differing loads or DC supplies.



# 8000 series

## Ruggedized switch joysticks

### DIMENSIONAL DRAWINGS - HANDLES

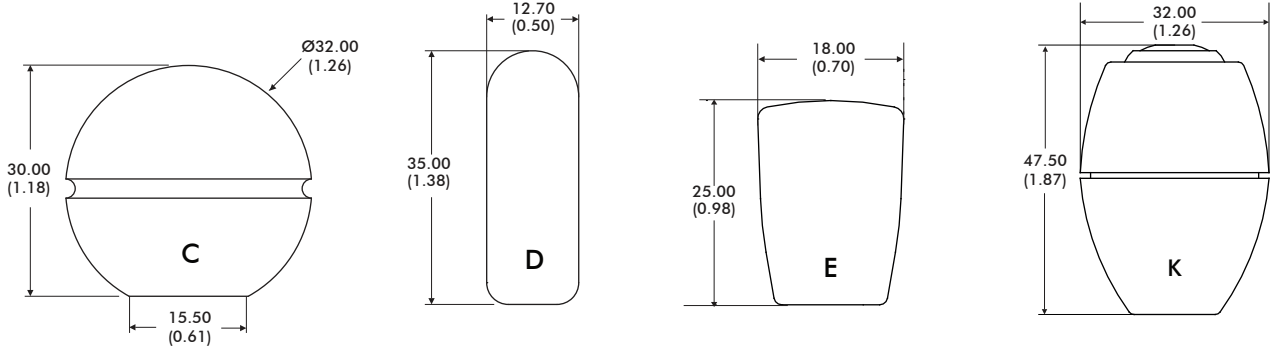
				
MATERIAL	Phenolic	Aluminum	Nylon	ABS
FINISH	Gloss	Anodised	Sparked Matt	Sparked Matt
STANDARD COLOR	Black	Black	Black	Black
OTHER COLORS	Not Available	Not Available	Upon Request	Not Available
NOTES:				Uses APEM IS Switch

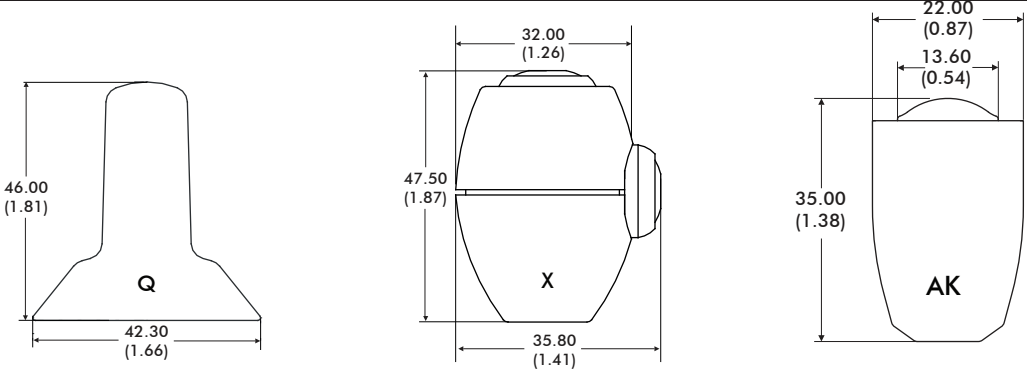
			
MATERIAL	Nylon	ABS	Aluminum
FINISH	Sparked Matt	Sparked Matt	Anodised
STANDARD COLOR	Black	Black	Black
OTHER COLORS	Not Available	Not Available	Not Available
NOTES:		Uses APEM IS Switch	Uses APEM IA Switch

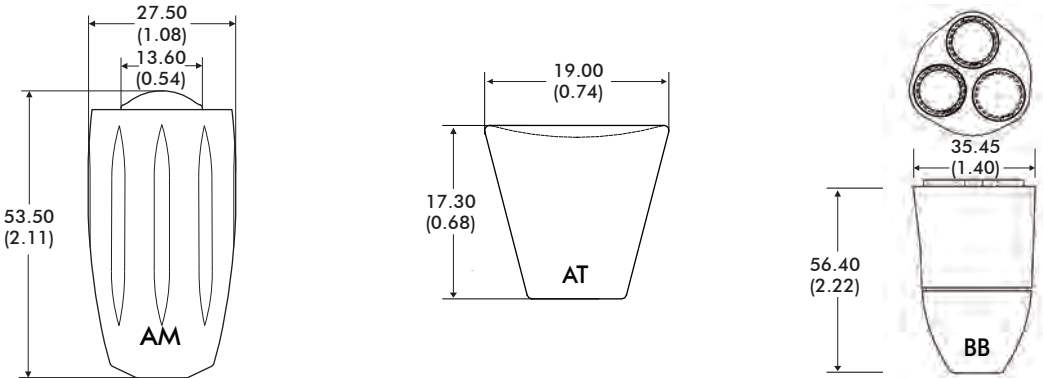
			
MATERIAL	Aluminum	Nylon	Nylon
FINISH	Anodised	Sparked Matt	Sparked Matt
STANDARD COLOR	Black	Black	Black
OTHER COLORS	Not Available	Upon Request	Not Available
NOTES:	Uses APEM IA Switch		Uses APEM IL Switch

1. Dimensions are in mm/(inch)



# 8000 series

## Ruggedized switch joysticks

### DIMENSIONAL DRAWINGS

#### GENERAL DIMENSIONS

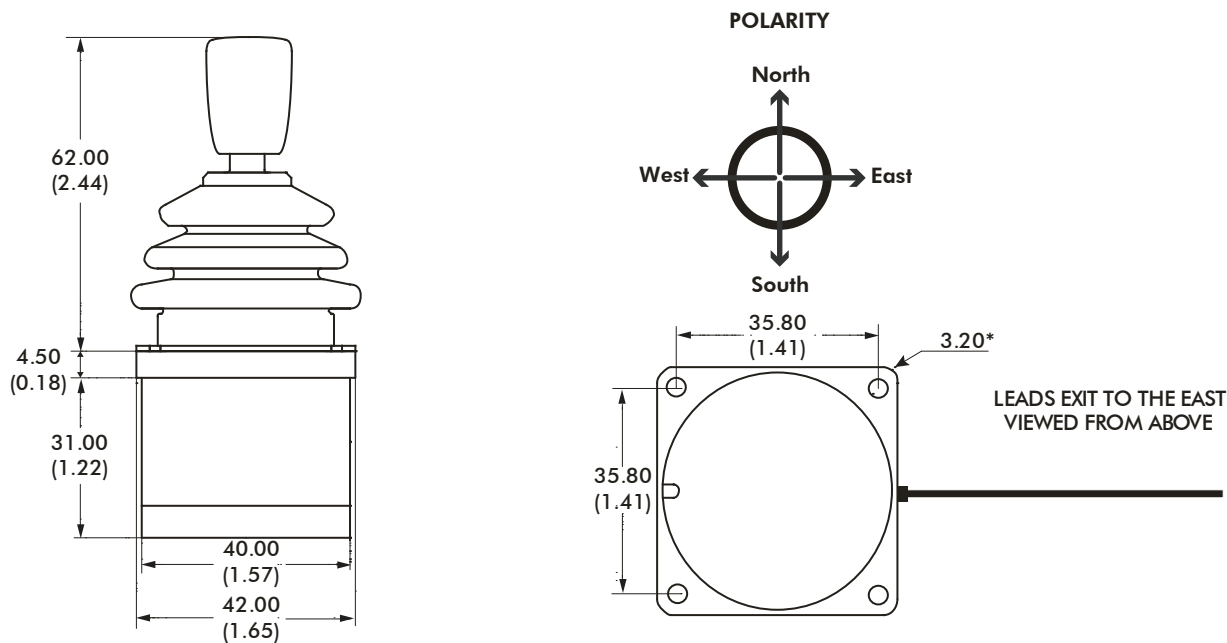

#### DROP IN MOUNTING - PANEL CUT-OUT & MOUNTING INSTALLATION

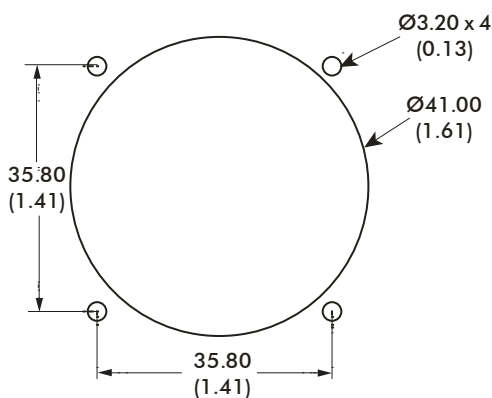

The joystick is dropped into the panel cut-out. The joystick and boot must be kept in place by bezel (option 6 & 7). For panel thickness of <3mm, M3 x 16 countersunk machine screws are recommended.

#### NOTES:

1. Dimensions are in mm/(inch)
2. The dimensions shown are for a generic 8000 Series with the conical E type handle. For specific dimensions of this or any other configuration please refer to the Factory.

# 8000 series

## Ruggedized switch joysticks

### MOUNTING INSTALLATION

#### MOUNTING OPTION A - PANEL CUT-OUT & MOUNTING INSTALLATION

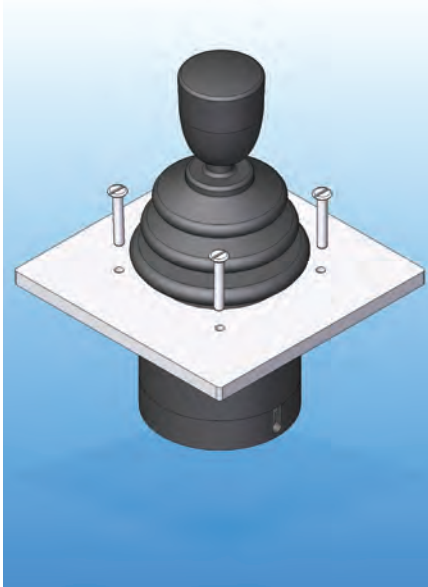

#### MOUNTING CUT-OUT

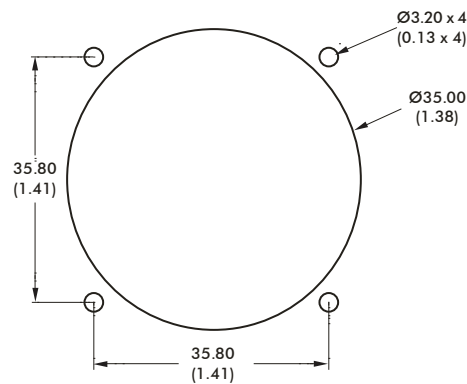

When mounted this way the panel acts as the bezel and no separate bezel is needed. M3 machine screws are recommended.

#### MOUNTING OPTION B - PANEL CUT-OUT & MOUNTING INSTALLATION

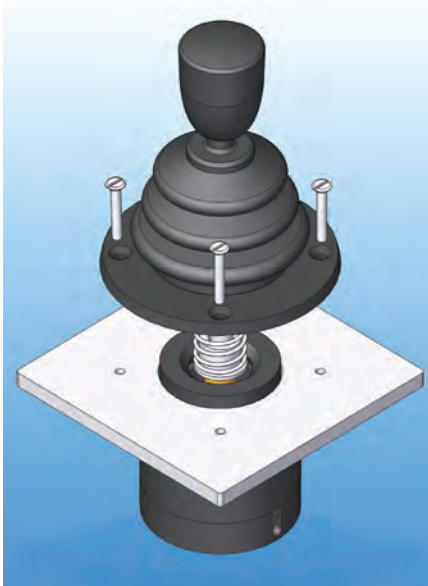

#### MOUNTING CUT-OUT

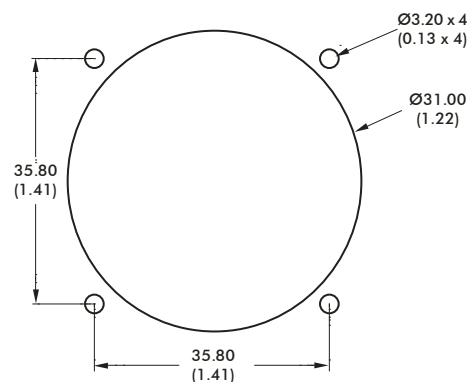

The joystick flange is mounted beneath the panel and the base of the boot must be brought through the panel cut-out and held in place with the circular bezel (option 4). For panel thicknesses of 3mm, M3 x 16 countersunk machine screws are recommended.

Note: When sub panel mounting, great care should be taken not to damage the boot, or any of the mechanism under the boot. All panel cut-outs should be free from sharp edges and swarf that may damage the boot.

# 8000 series

## Ruggedized switch joysticks

### SWITCHING OPTIONS

#### SINGLE AXIS CONFIGURATIONS

##### SWITCHING OPTION A

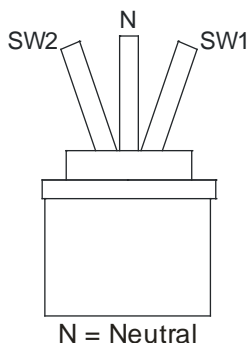

N = Neutral

One switch will actuate as the joystick moves away from center in either direction.

##### SWITCHING OPTION B

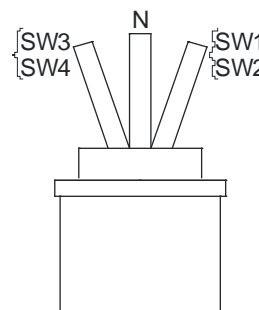

N = Neutral

Two switches will actuate as the joystick moves away from center, in either direction.

##### SWITCHING OPTION C

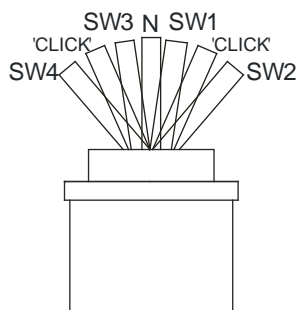

N = Neutral

As per option D, but with a mechanical detent between actuation of the first and second switch.

##### SWITCHING OPTION D

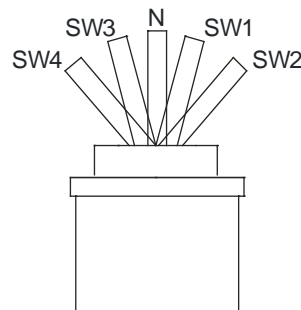

N = Neutral

One switch will actuate after 50% of travel, with a further switch at the end of travel, in either direction.

#### TWO AXES CONFIGURATIONS

##### SWITCHING OPTION E

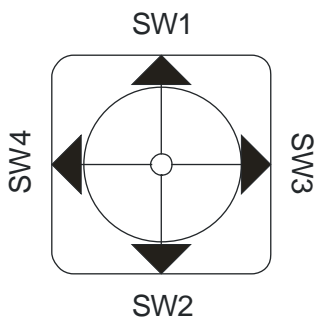

One switch will actuate in each of the four directions: North, South, East & West.

##### SWITCHING OPTION F

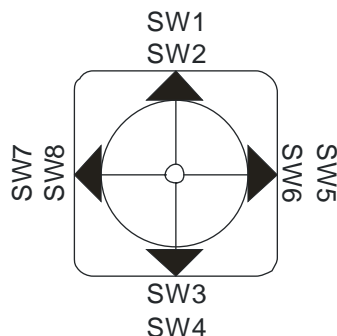

Two switches will actuate in each of the four directions: North, South, East & West.

# 8000 series

## Ruggedized switch joysticks

### CONFIGURATION OPTIONS

#### MICROSWITCHES

The 8000 Series utilizes industrial quality microswitches with changeover contacts. As standard, the switches are rated to a maximum of 1 Amp, and have gold plated contacts for reliable switching at low current levels. Please note when specifying a joystick with a pushbutton handle the characteristics of the pushbutton will be different from the microswitches. Please refer to Apem for full details and characteristics of your chosen configuration.

#### SWITCHING OPTIONS

The following configurations are available as standard :

Single Axis - Single Pole : One switch in each of the the two directions; North & South.

Single Axis - Double Pole : Two switches in each of the the two directions; North & South.

Single Axis - Progressive : One switch will actuate after 8 degrees of movement, with a further switch actuating after another 10 degrees of movement, in either direction.

Single Axis - Progressive with detents : As above, but with a mechanical detent at the point of the first switch actuation in each direction.

Dual Axes - Single Pole : One switch in each of the four positions; North, South, East and West.

Dual Axes - Double Pole : Two switches in each of the four positions; North, South, East and West.

Note : Double Pole switching is designed such that both switches in any given position trigger nominally together.

Many configurations are also available with a further microswitch actuating when the joystick is at center, for center detection purposes.

#### GUIDED FEEL

8000 Series joysticks may also be specified with guided feel. A joystick with guided feel moves more readily towards the poles (North, South, East and West) and whilst it can still move away from the poles, the force required to do so is greater. Unless specified otherwise, joysticks are supplied as standard without guiding. This standard configuration allows the user to move the joystick anywhere within the limiter with the same force and without any bias.

#### CABLE SPECIFICATION

As standard the joysticks are supplied utilizing the normally open contacts of the microswitches.

For connection to the normally closed contacts, please specify this as part of your special modification.

Cable information may be subject to specification, please refer to Apem for details. Connectors and custom looms may be fitted upon request.

14/0.12 - Fourteen strands of 0.12mm diameter tinned annealed copper wire PVC insulated to a nominal OD of 1mm			
Red	: Common	Black	: First Switch East
Blue	: Second Switch West	Yellow	: Second Switch East
Green	: First Switch West	Purple	: First Switch South
Orange	: Second Switch North	White	: Second Switch South
Brown	: First Switch North	Grey	: Center Detect Switch
7/0.127 - Seven strands of 0.127mm diameter tinned copper wire ETFE insulated, to a nominal OD of 0.7mm			
Orange	: First Pushbutton (Top of Handle)	Green	: Second Pushbutton
All 8000 Series are supplied with 150mm of twisted cable harness, with tinned ends.			



# IPD Launch

USB desktop controllers



Featuring ten programmable pushbuttons and a three axes Resistive joystick, the IPD Launch is an economical option for security professionals. Easy to operate and install with USB interface, the IPD Launch is a joystick solution for any size security installation.

## KEY FEATURES

- 3 axes joystick for P/T/Z control
- Ten pushbutton switches
- USB 1.1 HID compliant "game controller"
- Easy to use and operate





# IPD Launch

## USB desktop controllers

### SPECIFICATIONS

Joystick performance	–	Resistive three axes joystick
	–	X/Y/Z for positioning control
Joystick travel	–	36° for X and Y axes
	–	56° for Z axis
Centering	–	Dual spring, omni-directional
Joystick shaft	–	Nickel plated brass
Joystick boot	–	Thermostatic elastomer
Joystick handle	–	Glass filled nylon
Pushbutton performance	–	10 tactile pushbuttons on housing rated for 3,000,000 life cycles
Desktop housing	–	High impact ABS
Power	–	Via USB interface (5V DC)
	–	Consumption 32mA
Operating conditions	–	-25 to +85°C (-13 to +185°F)
Approvals	–	EN 55024:1998, EN 55022, CE
	–	FCC Part 15 Subpart B Class B
	–	RoHs compliant
Weight	–	435 g (0.96lb)
Interface	–	USB port
Connectors	–	USB Type A Male
	–	Cable Length: 2m; 6ft. 6.8in.
Systems support integration	–	Windows 7, Vista, XP, 2000
Supported protocols	–	USB HID 1.1 game controller
	–	Direct X (Gaming Control)
	–	Joystick: Three HID axes
	–	Pushbuttons: 10 HID buttons
	–	Uses standard DirectX HID drivers
	–	Connects directly to workstation PC
Environmental	–	For indoor use only

NOTE:  
All values are nominal

# IPD Launch

USB desktop controllers

DIMENSIONAL DRAWINGS

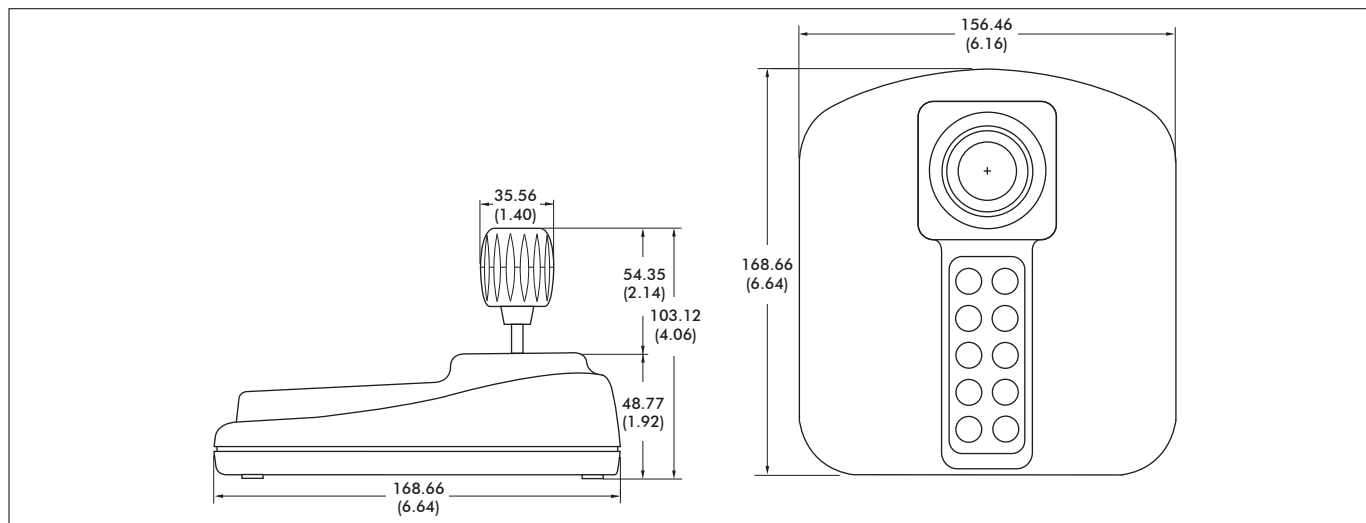

Note: Dimensions are in mm/(inch)

## USB 1.1 HID COMPLIANT GAME CONTROLLER

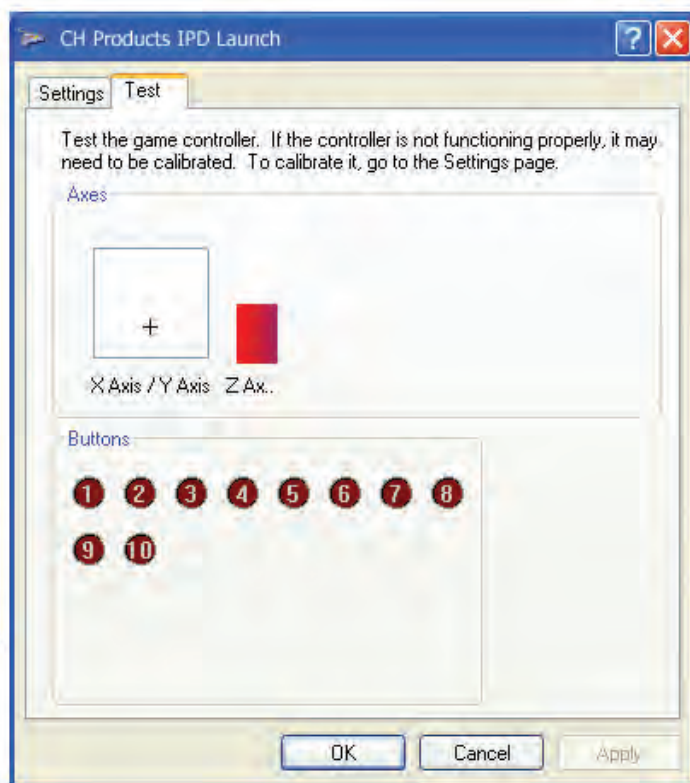

Note: To order the IPD Launch please refer to Part Number 100-450.



# IP Desktop

Professional USB desktop controllers



The network surveillance industry's #1 selling USB joystick, the IP Desktop features a two button three axes Hall effect joystick, 10 tactile pushbuttons and USB 1.1 interface. Recommended and used by the most innovative companies in network surveillance, the IP Desktop has become the industry standard for security professionals.

### KEY FEATURES

- 3 axes joysticks for P/T/Z control
- Programmable pushbutton switches
- USB 1.1 HID compliant "game controller"
- Easy to use and operate
- Optional programming software



# IP Desktop

## Professional USB desktop controllers

### SPECIFICATIONS

Joystick performance	–	Hall effect three axes joystick
	–	X/Y/Z for positioning control
Joystick travel	–	36° for X and Y axes
	–	60° for Z axis
Centering	–	Single spring, omni-directional
Joystick shaft	–	Stainless steel
Joystick boot	–	Neoprene
Joystick handle	–	Glass filled nylon
Pushbutton performance	–	10 tactile pushbuttons on housing
	–	Two tactile pushbuttons on joystick
	–	3,000,000 cycles
Desktop housing	–	High impact ABS
Power	–	Via USB interface (5V DC)
	–	Consumption 32mA
Operating conditions	–	-25°C to +85°C (-13°F to +185°F)
Approvals	–	EN 55024:1998, EN 55022, CE
	–	FCC Part 15 Subpart B Class B
	–	RoHs compliant
Weight	–	440 g (0.97lb)
Interface	–	USB port
Connectors	–	USB Type A Male
	–	Cable Length: 2m; 6ft. 6.8in
Systems support integration	–	Windows 7, Vista, XP, 2000
Supported protocols	–	USB HID 1.1 game controller
	–	Direct X (Gaming Control)
	–	Joystick: Three HID axes
	–	Pushbuttons: 12 HID buttons
	–	Uses standard DirectX HID drivers
	–	Connects directly to workstation PC
Environmental	–	For indoor use only

**NOTE:**

All values are nominal

- IP Desktop Software is an optional utility that creates a joystick/mouse combination device and allows users to toggle between both devices with the press of a button. In addition to dual joystick/mouse functionality, IP Desktop Software creates an additional fourth joystick axis, "R." The additional "R" axis is ideally suited for jog/shuttle control of video playback.
- IP Desktop Software is designed to work with the IP Desktop range in a Windows based operating system.



# IP Desktop

## Proportional USB desktop controllers

### DIMENSIONAL DRAWINGS

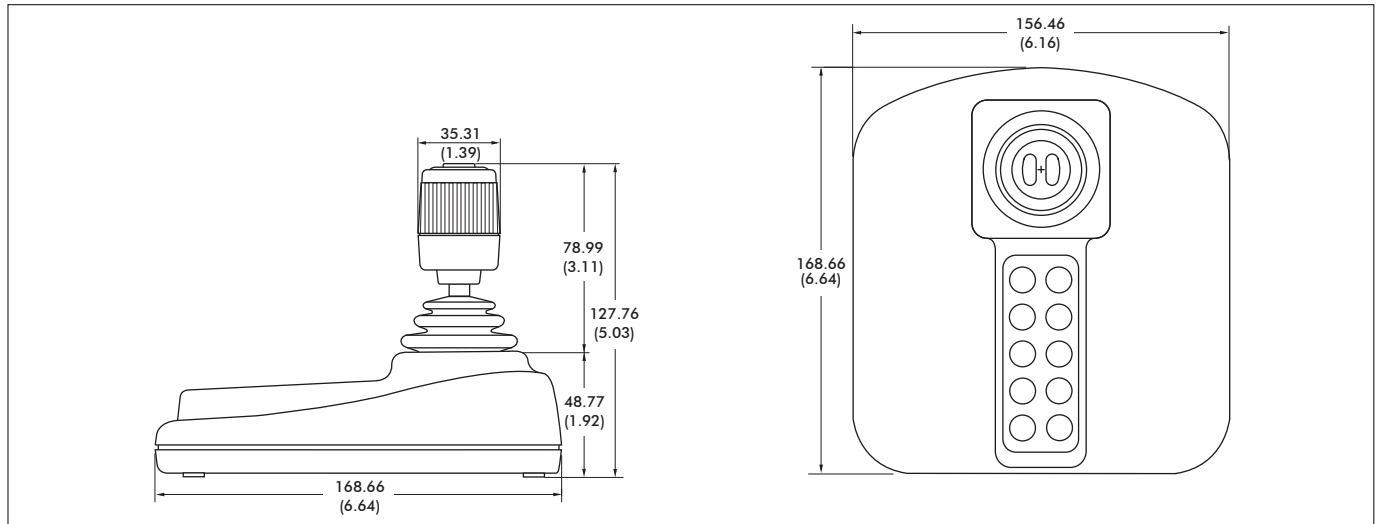

Note: Dimensions are in mm/(inch)

### USB 1.1 HID COMPLIANT GAME CONTROLLER

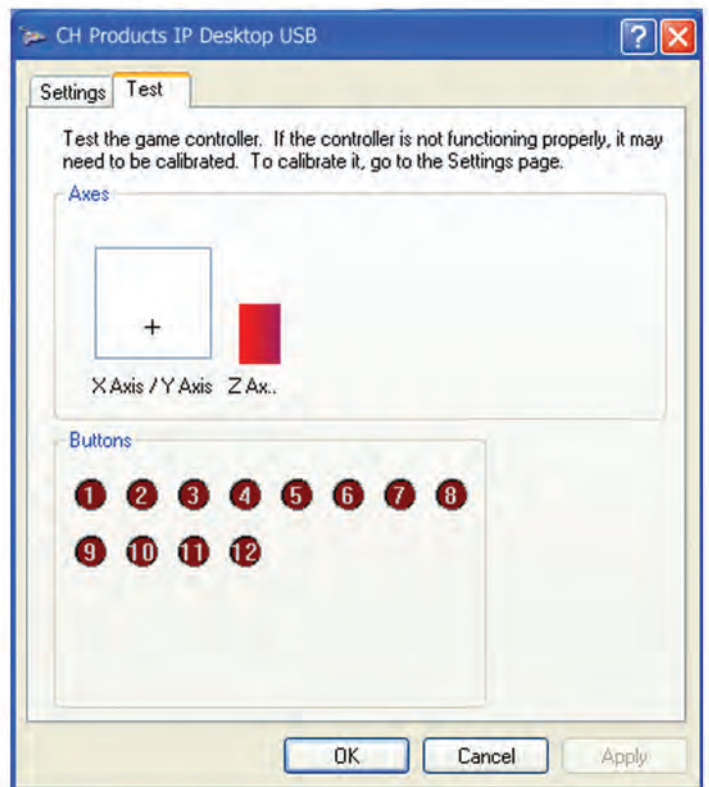
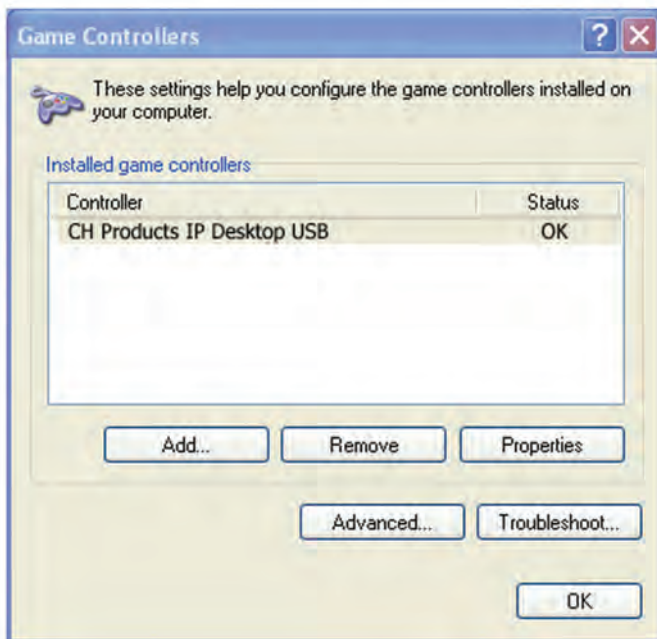

Note: To order the IPD Desktop please refer to Part Number 100-550 (Gray or Black).





# IPD Ultima

Premium USB desktop controllers



The IPD Ultima features a premium soft touch Business Blue coating, 10 vibrant high efficiency LED pushbuttons as well as a precision two button three axes Hall effect joystick. Featuring USB 1.1 HID compliant interface, the IPD Ultima brings sophistication and comfort to PTZ network camera control.

## KEY FEATURES

- 3 axes joystick for P/T/Z control
- LED pushbutton switches
- USB 1.1 HID compliant "game controller"
- Soft touch Business Blue coating
- Optional programming software



# IPD Ultima

## Premium USB desktop controllers

### SPECIFICATIONS

Joystick performance	-	Hall effect three axes joystick X/Y/Z for positioning control
Joystick travel	-	36° for X and Y axes 60° for Z axis
Centering	-	Single spring, omni-directional
Joystick shaft	-	Stainless steel
Joystick boot	-	Neoprene
Joystick handle	-	Glass filled nylon
Pushbutton performance	-	10 vibrant, high efficiency back lit LED pushbuttons rated for 10,000,000 life cycles - Two tactile pushbuttons on joystick rated for 3,000,000 life cycles
Desktop housing	-	High impact ABS Soft touch Business Blue coating
Power	-	Via USB interface (5V DC) Consumption 300mA
Operating conditions	-	-25 to +85°C (-13 to +185°F)
Approvals	-	EN 55024:1998, EN 55022, CE FCC Part 15 Subpart B Class B RoHs compliant
Weight	-	455 g (1.00lb)
Interface	-	USB port
Connectors	-	USB Type A Male Cable Length: 2m; 6ft. 6.8in.
Systems support integration	-	Windows 7, Vista, XP, 2000
Supported protocols	-	USB HID 1.1 game controller Direct X (Gaming Control) Joystick: Three HID axes Pushbuttons: 12 HID buttons Uses standard DirectX HID drivers Connects directly to workstation PC
Environmental	-	For indoor use only

NOTE:  
All values are nominal

- IP Desktop Software is an optional utility that creates a joystick/mouse combination device and allows users to toggle between both devices with the press of a button. In addition to dual joystick/mouse functionality, IP Desktop Software creates an additional fourth joystick axis, "R." The additional "R" axis is ideally suited for jog/shuttle control of video playback.
- IP Desktop Software is designed to work with the IP Desktop range in a Windows based operating system.

# IPD Ultima

Premium USB desktop controllers

## DIMENSIONAL DRAWINGS

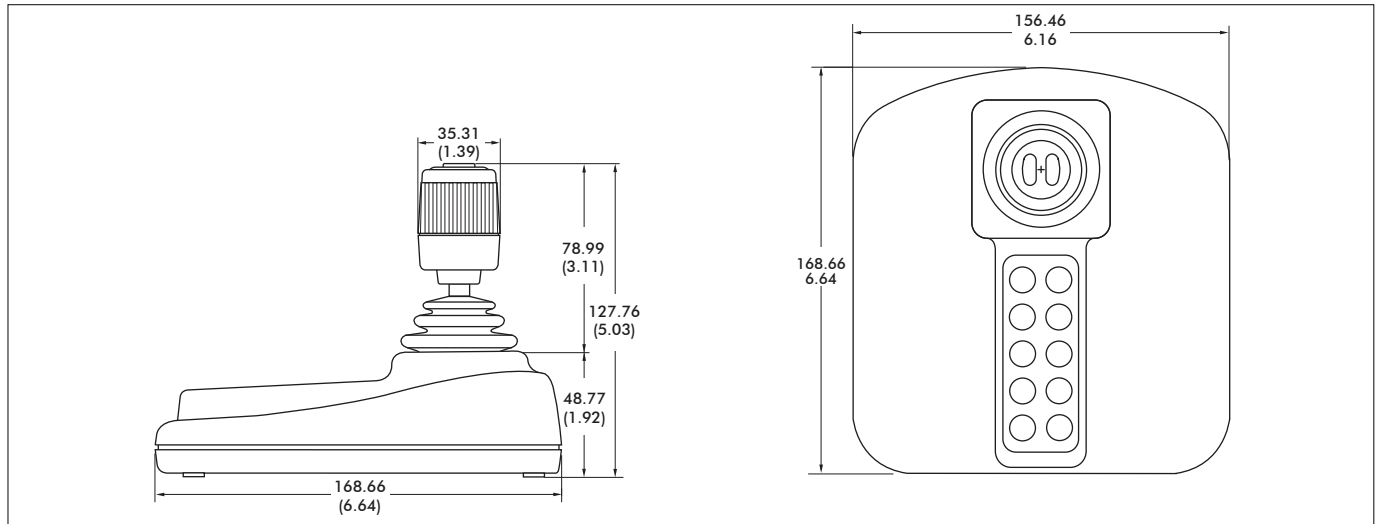

Note: Dimensions are in mm/(inch)

## USB 1.1 HID COMPLIANT GAME CONTROLLER

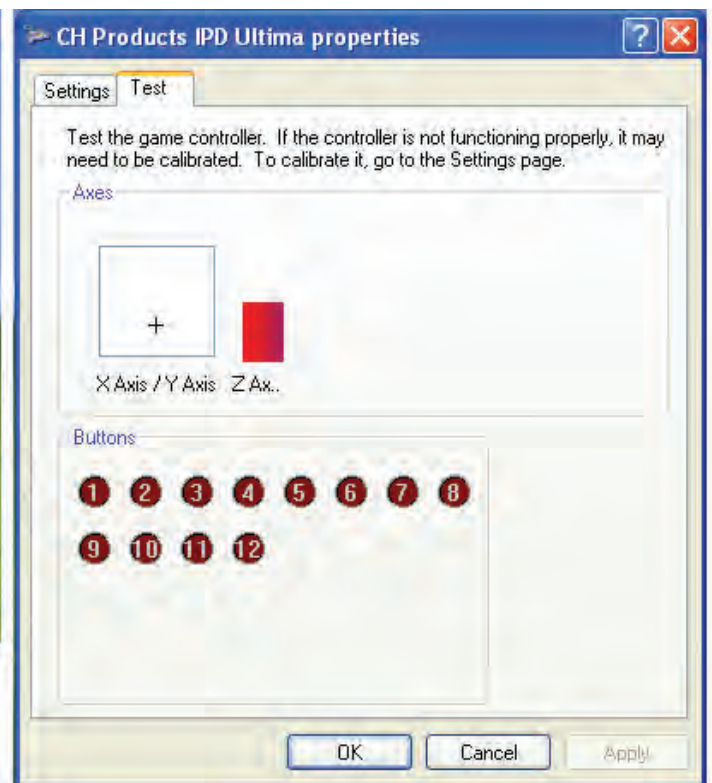
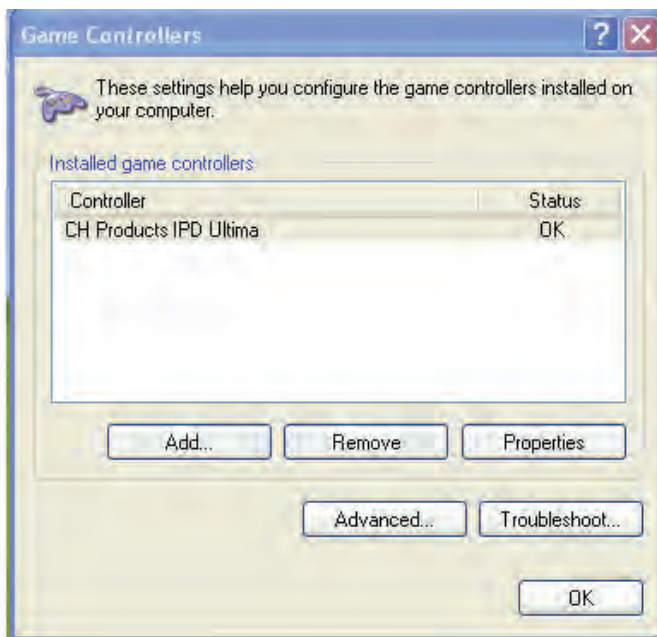

Note: To order the IPD Ultima please refer to Part Number 100-650.





# VM Desktop

USB multifunction controller



CH Products' VM Desktop provides advanced features such as a 3 axes Hall effect Joystick, jog/shuttle dial, 27 user-defined pushbuttons and USB 1.1 interface for powerful control of video surveillance, recording and video management functions. The VM Desktop is designed for critical security installations including airports, casinos, transit stations and stadiums.

## KEY FEATURES

- 3 axes joystick for P/T/Z control
- 27 programmable pushbuttons
- Jog/shuttle dial
- USB 1.1 HID compliant  
"game controller"
- Easy to use and operate
- Functions determined by  
controlled application



# VM Desktop

## USB multifunction controllers

### SPECIFICATIONS

Joystick performance	-	Hall effect three axes joystick X/Y/Z for positioning control
Joystick travel	-	36° for X and Y axes 60° for Z axis
Centering	-	Single spring, omni-directional
Joystick shaft	-	Stainless steel
Joystick boot	-	Neoprene
Joystick handle	-	Glass filled nylon
Jog/shuttle performance	-	Spring loaded shuttle ring travel $\pm 40^\circ$ Smooth action knob rotates 360°
Pushbutton performance	-	27 programmable pushbuttons rated for 500,000 life cycles Lighting: high efficiency LED Pushbutton material: silicon "Mouse" pushbuttons are rated for 10,000,000 life cycles
Desktop housing	-	High impact ABS
Power	-	Via USB interface (5V DC) Consumption 1A
Operating conditions	-	-25°C to +85°C (-13°F to +185°F)
Approvals*	-	EN 55024:1998, EN 55022, FCC Part 15 Subpart B Class B RoHs compliant
Interface	-	USB port Uses standard DirectX HID drivers Connects directly to workstation PC
Connectors	-	USB Type A Male Cable Length: 2m (6ft. 6.8in)
Systems support integration	-	Windows 7, Vista, XP, 2000
Supported protocols	-	USB HID 1.1 game controller Direct X (Gaming Control) Joystick: Three HID axes Pushbuttons: 12 HID buttons Uses standard DirectX HID drivers Connects directly to workstation PC
Environmental	-	For indoor use only
Boxed weight	-	1.33kg (47oz)

#### NOTE:

All values are nominal

- CH Products' Video Management controller features 27 programmable pushbuttons. The numeric keypad module is ideal for camera selection, presets, and touring functions. Button labels and legends may be customized for specific applications.
- The VM Desktop features a jog/shuttle dial for total control over digital video monitoring and management. In supported applications, the 360 degree jog knob may be used for editing frame-by-frame and the spring-loaded shuttle ring for variable forward and reverse speed control of captured sequences.
- Featuring USB 1.1 interface, the VM Desktop integrates seamlessly with software applications supporting USB joystick inputs via Microsoft DirectX. No device driver or SDK is required. The VM Desktop is recognized as a standard HID "game controller" 4 axes/29 button joystick. The VM Desktop's axes and buttons are programmable and function assignment is dependant on the controlled application.



# VM Desktop

USB multifunction controllers

DIMENSIONAL DRAWINGS

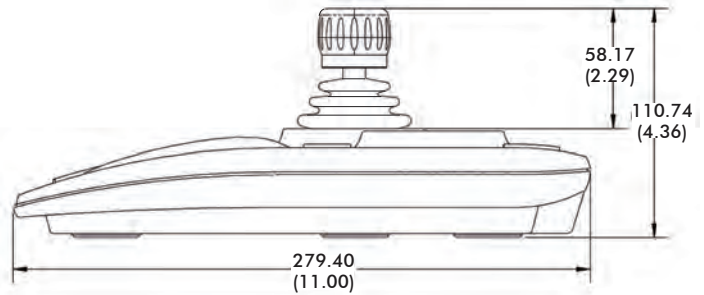
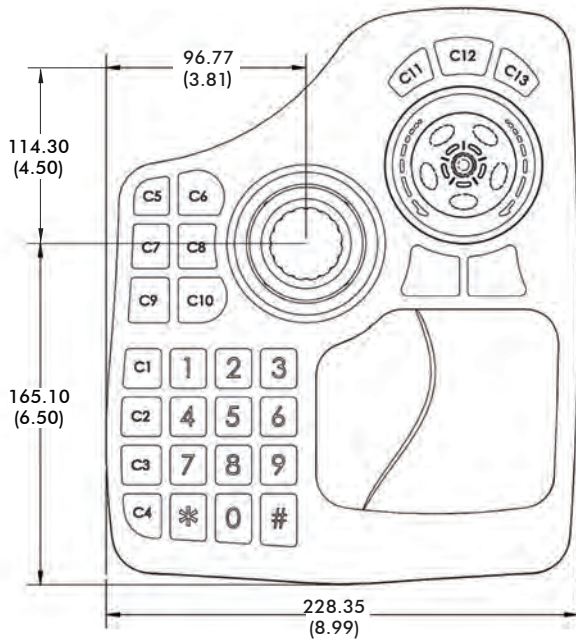

- Notes: - Dimensions are in mm/(inch)  
 - Supplied individually boxed with instruction booklet

## USB 1.1 HID COMPLIANT GAME CONTROLLER

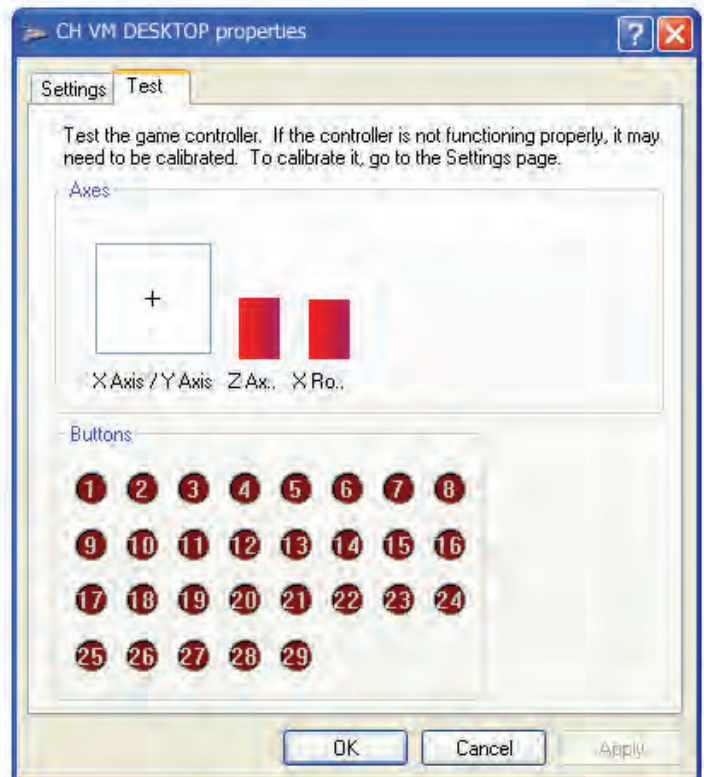

Note: To order the VM Desktop please refer to Part Number 100-590.



# TS series

Proportional Hall effect thumbsticks



The TS Series Thumbstick is a proportional two axes joystick in a miniature package. Featuring non-contacting Hall effect technology for long life performance, the TS Series Thumbstick is available with multiple linear output options including single and dual (redundant) outputs. It is similar in size and operation to "gamepad" controls, but in a rugged industrial package. Typical applications include pendant and remote controls as well as joystick handle and arm rest integration.



## KEY FEATURES

- 1 or 2 axes
- USB outputs available
- Non-contact Hall effect technology
- Submersible to 1m (3.28ft) per IP68
- Pressure washable to IP69K
- Redundant outputs available
- Rear or drop-in mounting available





# TS series

## Proportional Hall effect thumbsticks

### OPTION SELECTION

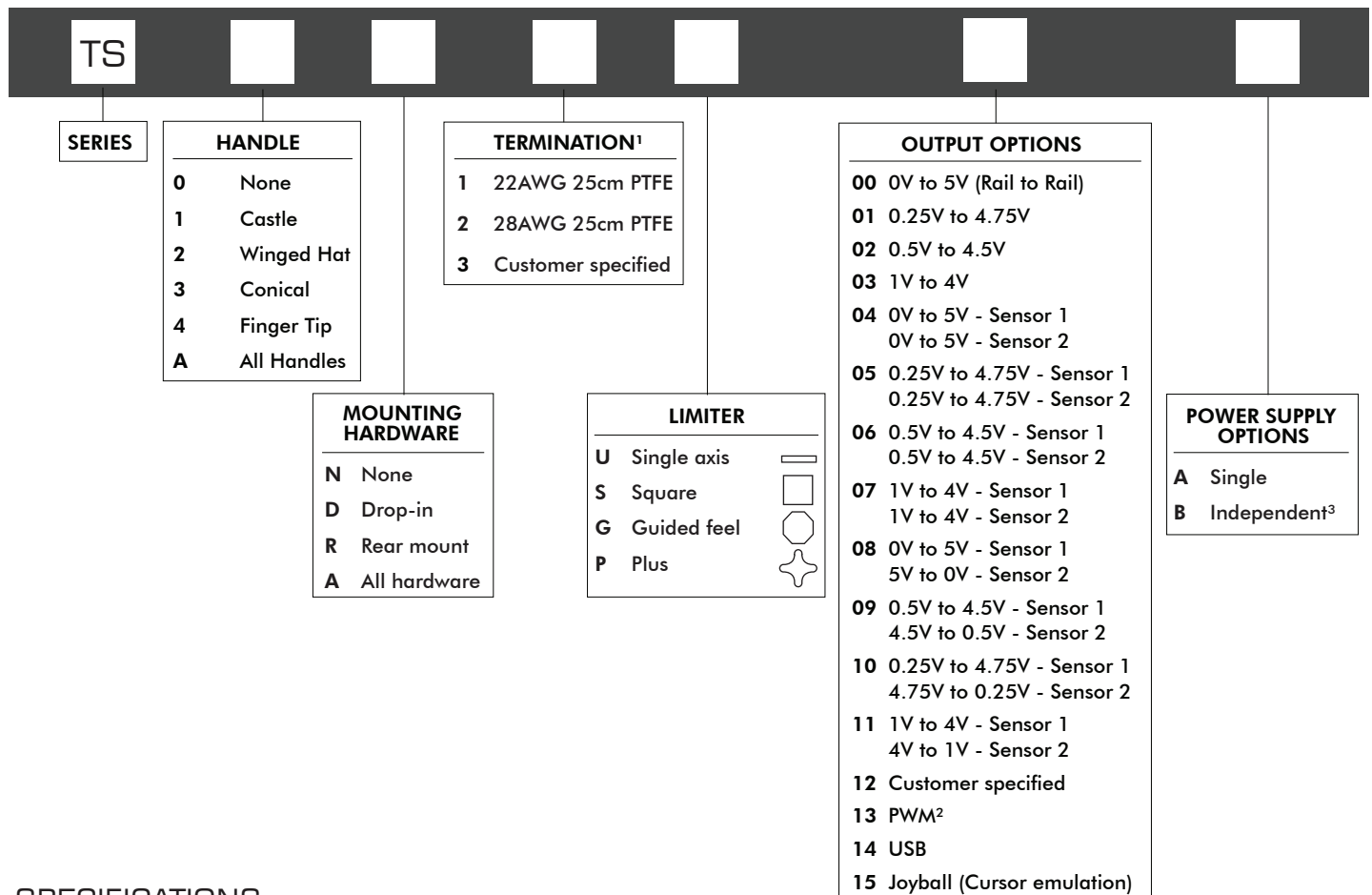

### SPECIFICATIONS

MECHANICAL (FOR X, Y AXES)		
Operating Force	-	3.1N±0.5N (0.70lbf±0.11lbf) <sup>4</sup>
Maximum Vertical Load	-	200N (45lbf) <sup>4</sup>
Maximum Horizontal Load	-	150N (33.7lbf) <sup>4</sup>
Mechanical Angle of Movement	-	50°
Expected Life	-	1 million cycles
Mass/weight	-	18.25g ± 5.0g (0.64oz±0.18oz)
Lever Action (Centering)	-	Spring centering

ENVIRONMENTAL		
Operating Temperature	-	-40°C to +85°C (-40°F to +185°F)
Storage Temperature	-	-40°C to +85°C (-40°F to +185°F)
Sealing	-	IP68, IP69K <sup>5</sup>
EMC Immunity Level	-	EN61000-4-3
EMC Emissions Level	-	EN61000-6-3:2001
ESD	-	EN61000-4-2

ELECTRICAL SENSOR		
Resolution	-	1.22mV
Supply Voltage Range	-	5.00V±0.01V
Reverse Polarity Max	-	-10V
Overvoltage Max	-	20V
Output Impedance	-	2Ω
Return to Center Voltage Tolerance	-	±200mV initial

#### NOTES:



Mounting accessories.

Standard hardware includes:

- For the Drop-in option - 4 push in connectors, drop-in bezel and an O-ring.
- For the Rear mount option: 4x1/2 FH SS Phil Screws and a rear mount bezel.

- 1-1 - Wires are thick, robust, and best suited for stand alone applications.
- 1-2 - Wires are thin and best suited for tightly constrained wire routing.

2 Contact factory for PWM configuration.

3 Only available on dual output.

4 Force applied to the top of the castle cap.

5 All options are IP68 and IP69K rated, however Drop-in mounting does not prevent panel ingress.

- All values are nominal

# TS series

## Proportional Hall effect thumbsticks

### DIMENSIONAL DRAWINGS

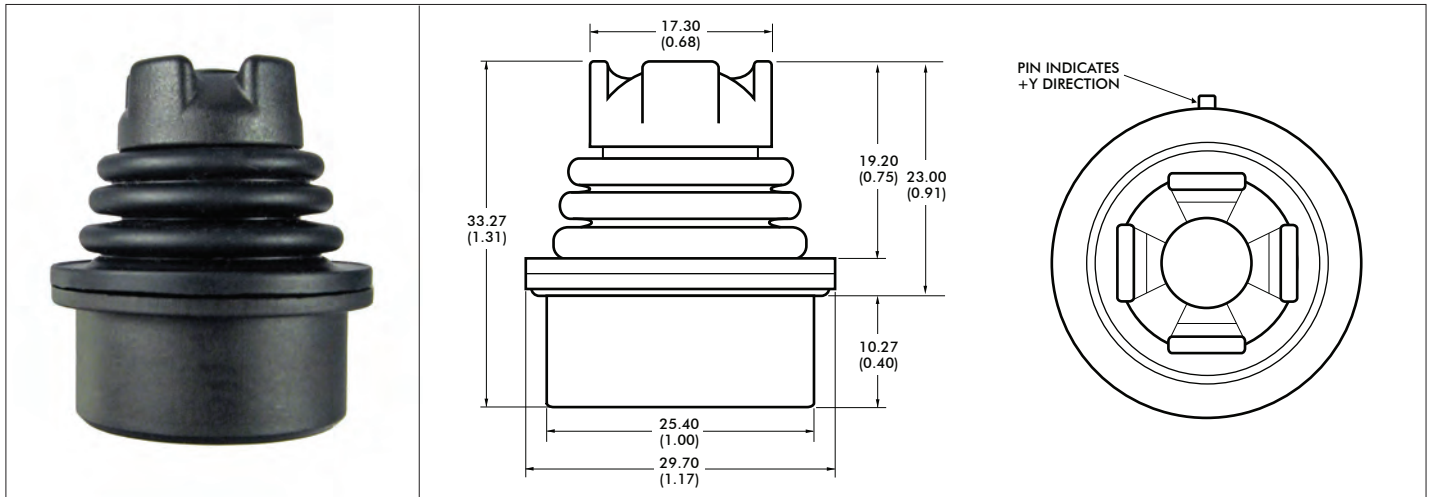

### HANDLE OPTIONS

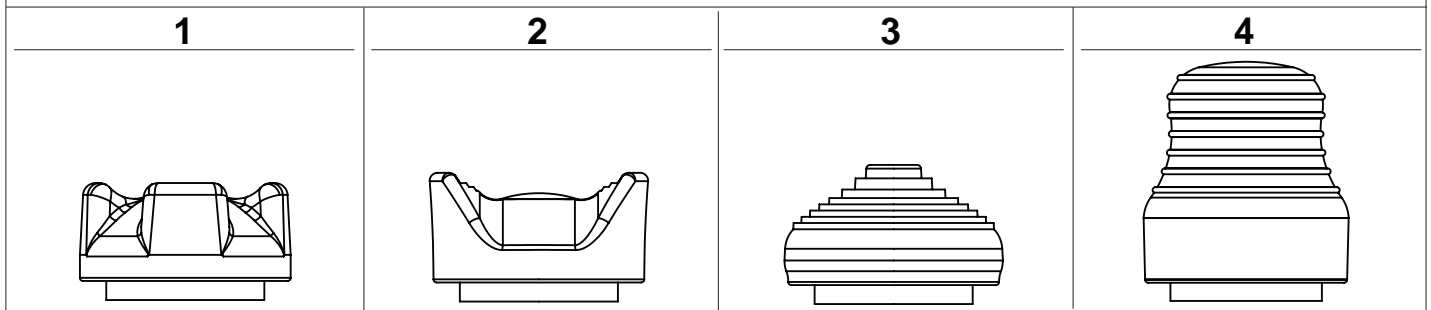

### MOUNTING OPTIONS

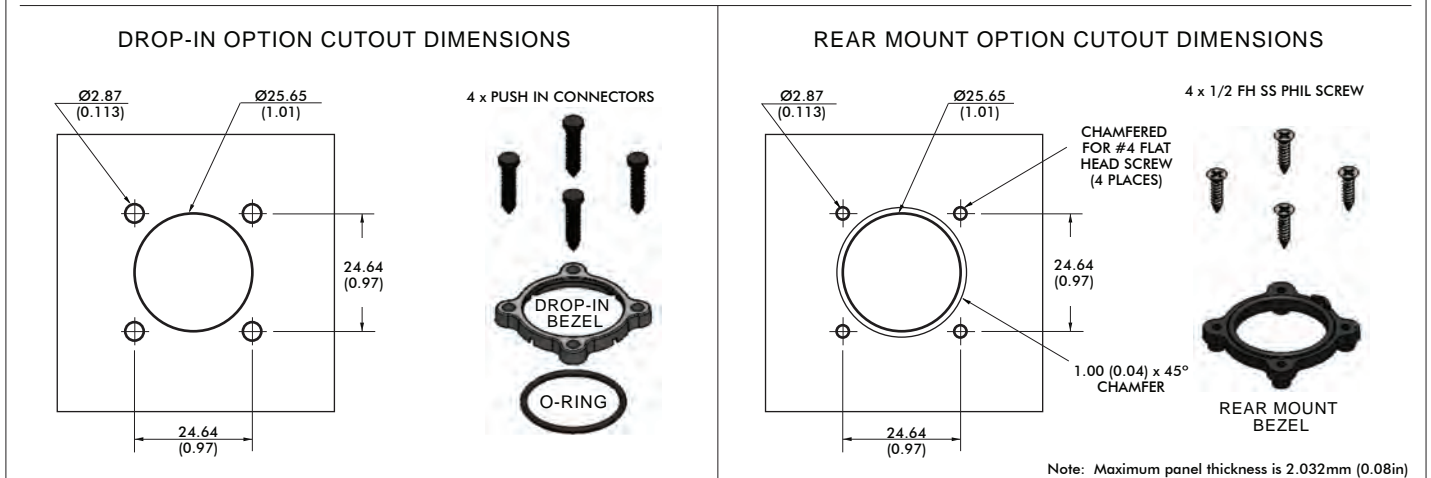

Note: Dimensions are in mm/(inch)



# TS series

## Proportional Hall effect thumbsticks

### CONFIGURATION OPTIONS

#### LINEAR OUTPUT OPTIONS

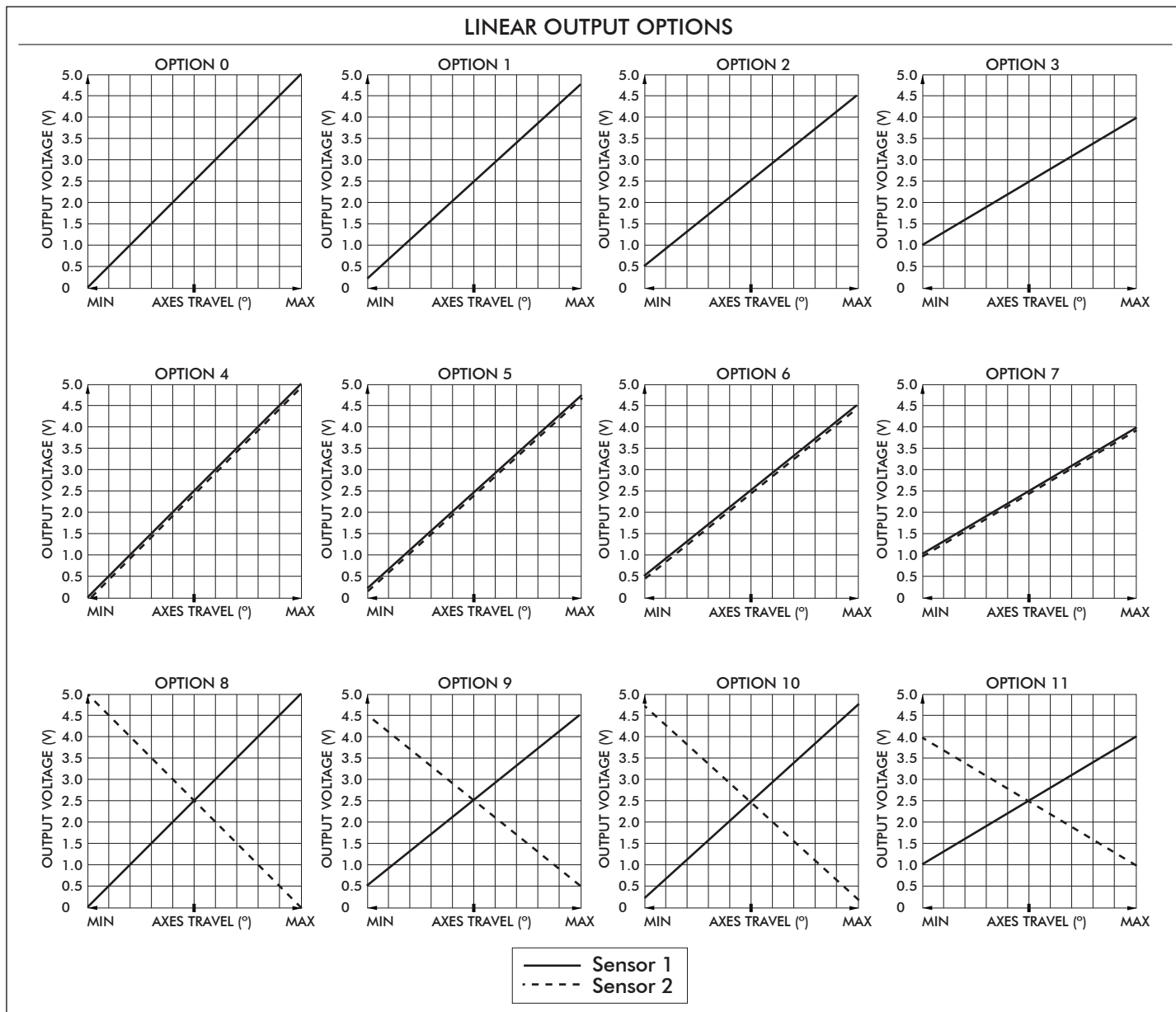

#### WIRING

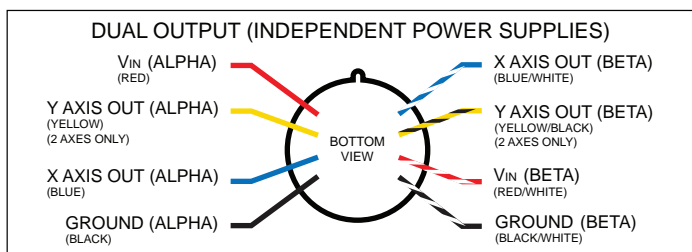
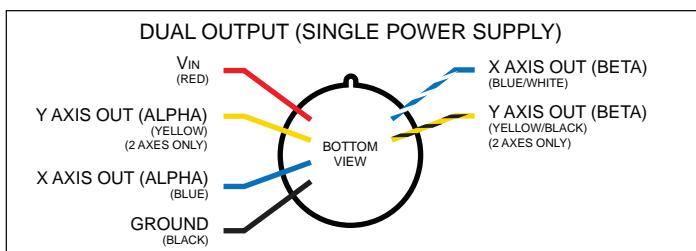
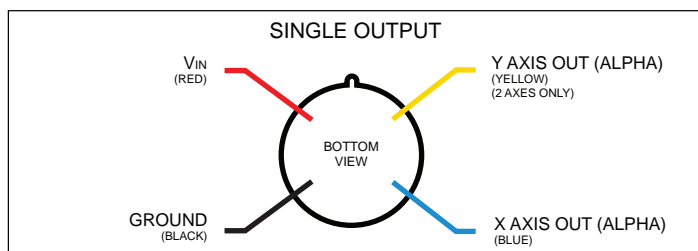



# TS series

## Proportional Hall effect thumbsticks

### CONFIGURATION OPTIONS - continued

#### ADDITIONAL OUTPUT OPTIONS

#### PLUG-AND-PLAY SOLUTIONS:

#### USB

Featuring USB 1.1 HID compliant interface, CH Products' USB joysticks are recognized as standard HID "game controller" devices. Adhering to the HID specification, CH Products' USB joysticks are plug-and-play with most versions of Windows and Linux. Joystick button and axes assignments are dependent upon the controlled application.

#### FEATURES

- USB 1.1 HID compliant "game controller" device
- Easy to install and operate
- Functions determined by controlled application

#### SUPPLIED WIRING

USB: USB Male Type A Connector with overmolded cable  
(Optional ruggedized military connectors are available.)



USB Male Type A Connector

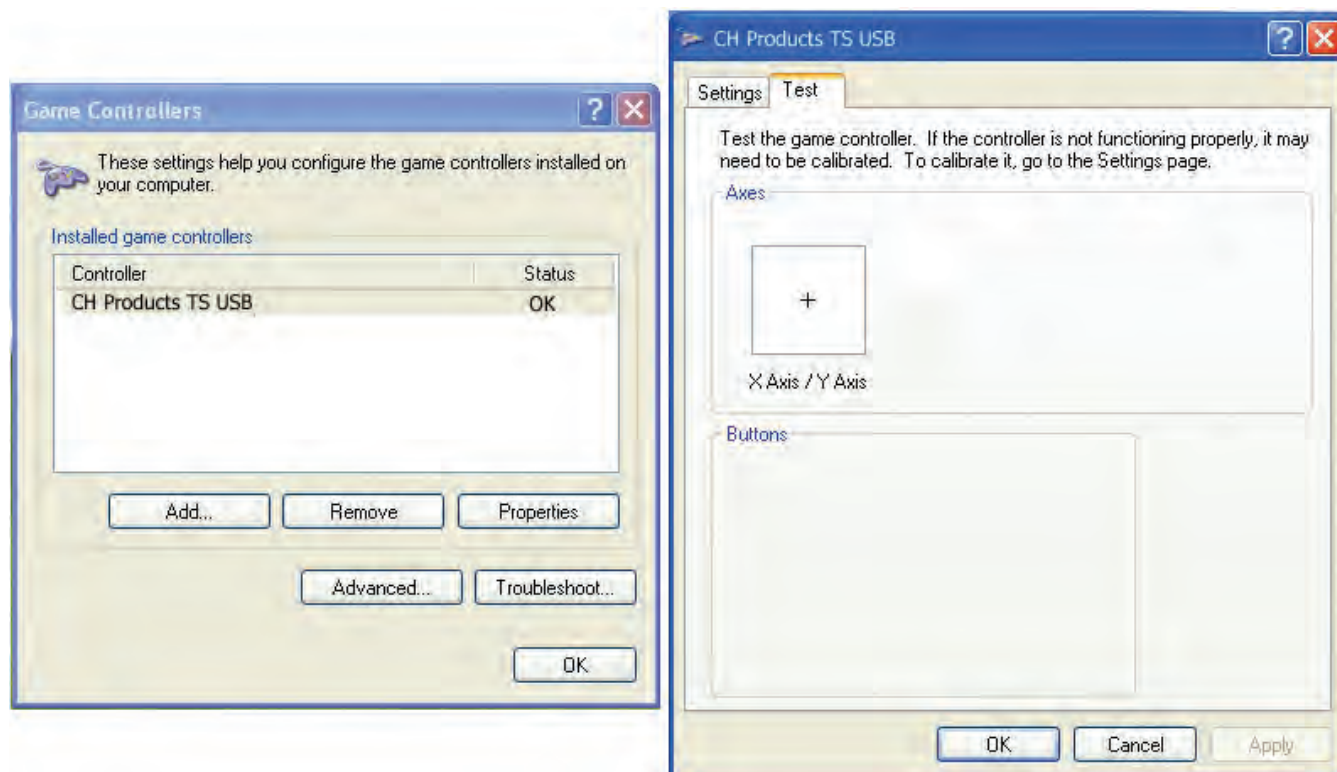

# TS series

## Proportional Hall effect thumbsticks

### CONFIGURATION OPTIONS

#### ADDITIONAL OUTPUT OPTIONS

### JOYBALL (CURSOR EMULATION)

The Joyball option converts multi-axis joystick output into a mouse, trackball, or cursor control device. The joystick's internal microprocessor converts absolute axis position into a cursor velocity, which is translated as a relative trackball or mouse position. Supported protocols: USB.

#### APPLICATIONS

The Joyball option is ideal for vehicle applications subjected to dirt and high vibration which make operating a traditional cursor control device difficult. The Joyball option is widely used in shipboard and military applications.

#### FEATURES

- HID compliant "pointing device"
- Plug-and-play with USB option
- Ideal for marine GPS and navigation

#### SUPPLIED WIRING

USB: USB Male Type A Connector with overmolded cable.

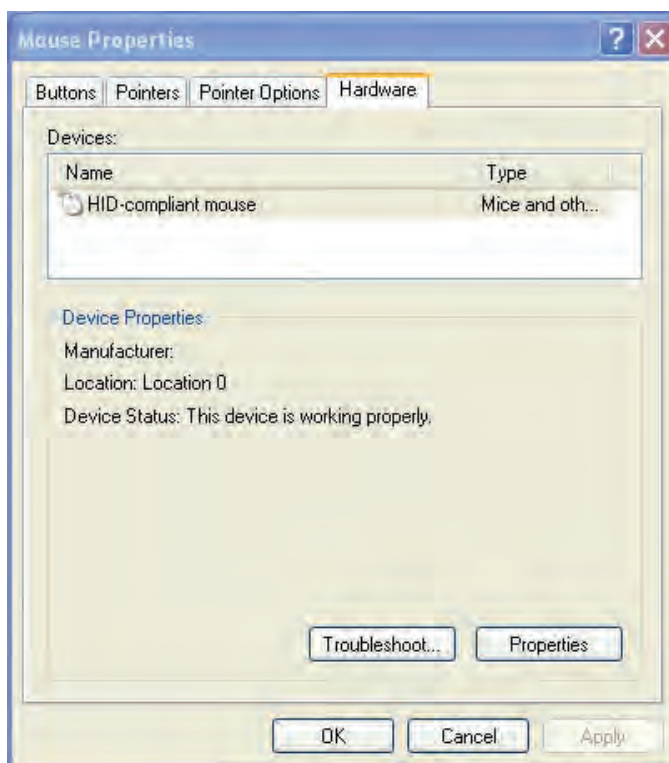



# APEM

## TW series

Hall effect thumbwheels



The TW Series thumbwheel is a self centering single-axis device developed for thumb-actuated applications requiring proportional output. Utilizing non-contacting Hall effect technology for long life performance, the TW Series thumbwheel delivers up to 5 million thumb actuations. Configuration options include choice of linear voltage outputs as well as wheel colors. The TW Series thumbwheel is available as a stand-alone device or may be incorporated into one of our custom joysticks.



### KEY FEATURES

- 5 million cycles
- Hall effect technology
- Proportional control
- Self-centering single-axis design
- Choice of wheel colors: red, gray, black, or blue
- EMI/RFI immunity



# TW series

## Hall effect thumbwheels

### OPTION SELECTION

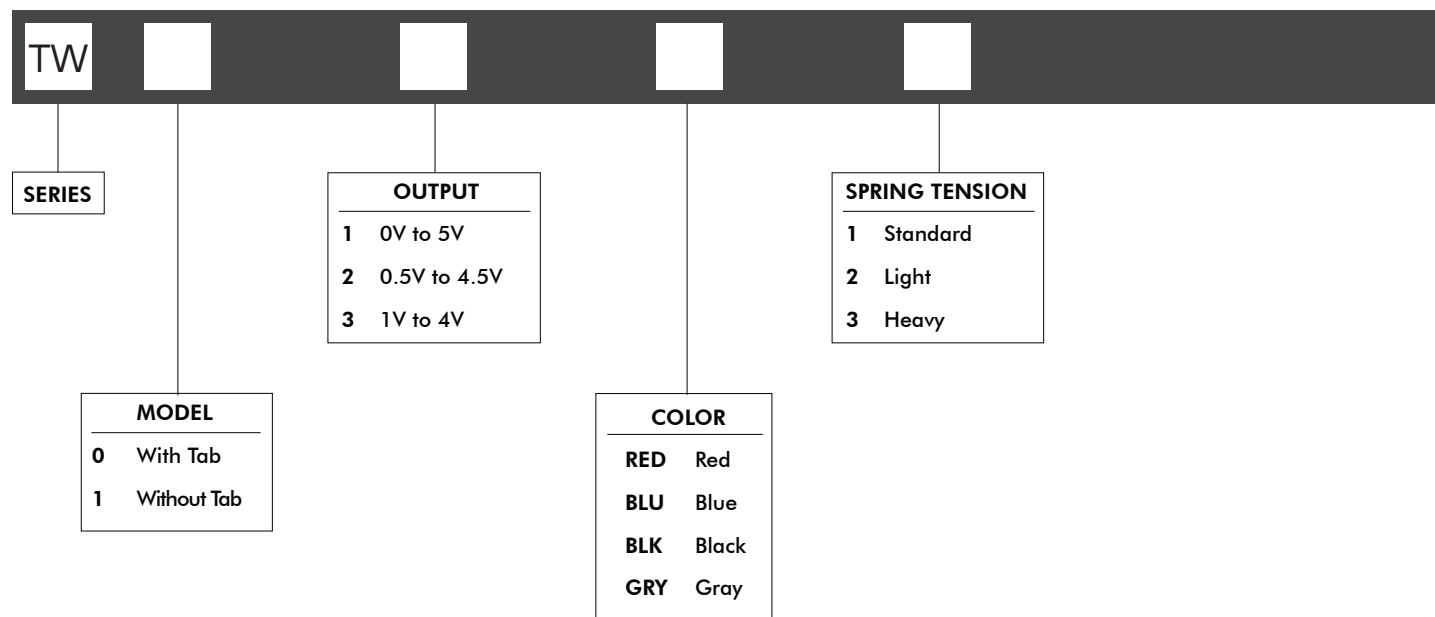

**NOTES:**



Mounting accessories: steel spring retainer, insertion tool, and sealing gasket.

### SPECIFICATIONS

MECHANICAL (FOR X, Y AXES)		
Break Out Force	-	0.7N (0.15lbf)
Mechanical Angle of Movement	-	80°
Expected Life	-	5 million cycles
Lever Action (Centering)	-	Spring Centering

ENVIRONMENTAL		
Operating Temperature	-	-40°C to +85°C (-40°F to +185°F)
Storage Temperature	-	up to +85°C (+185°F)
Sealing	-	IP67*

ELECTRICAL		
Sensor	-	Hall effect
Resolution	-	3.2mV
Supply Voltage Range	-	4.5 - 5.5V
Reverse Polarity Max	-	-16V
Overtoltage Max	-	16V
Output Impedance	-	1.5Ω
Return to Center Voltage (No Load)	-	±40mV
Current Consumption Max	-	8.3mA

**NOTES:**

- All values are nominal.
- Exact specifications are subject to configuration. Contact Technical Support for the performance of your specific configuration.
- \* Electronics sealed to IP67.



# TW series

## Hall effect thumbwheels

### DIMENSIONAL DRAWINGS

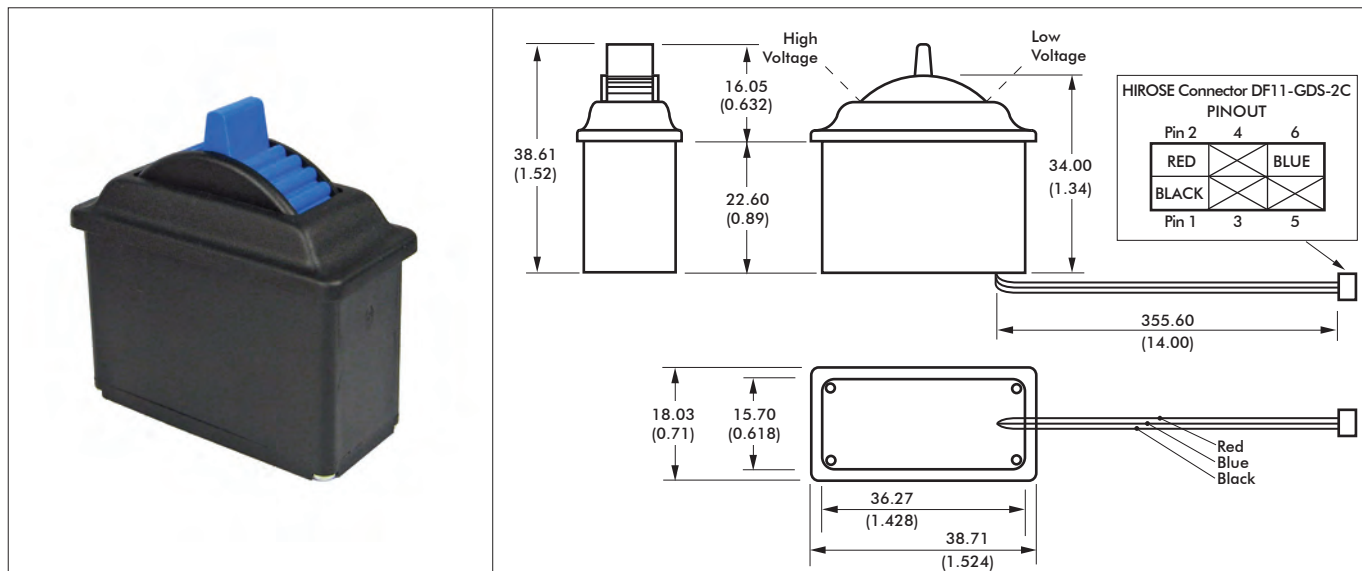

#### MOUNTING OPTIONS

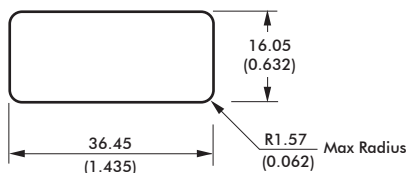

#### STEEL SPRING RETAINER\*

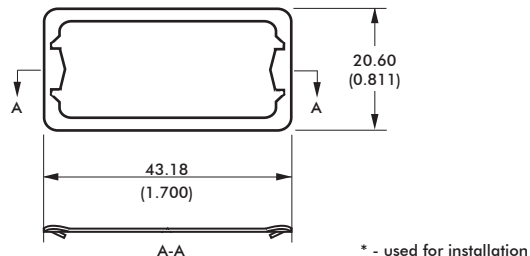

#### NOTES:

1. Dimensions are in mm/(in)

#### EXAMPLE APPLICATION



#### INSTALLATION

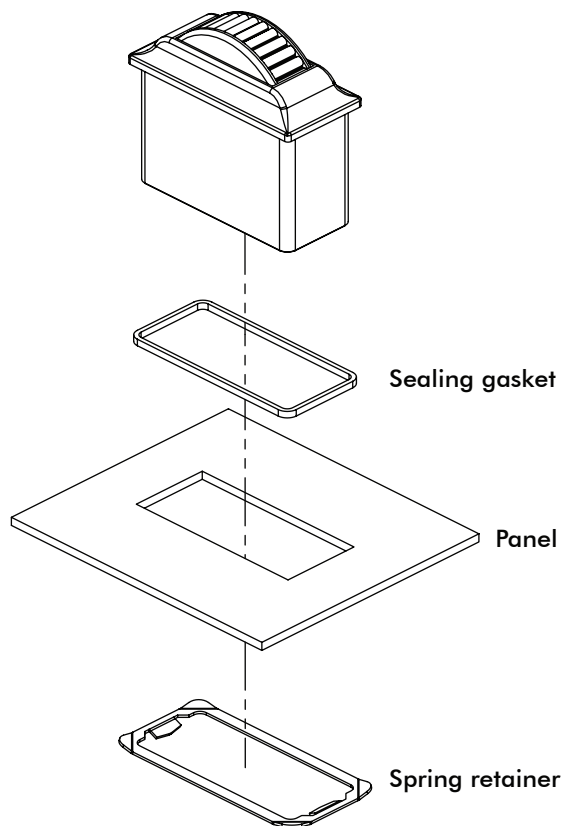



# TW series

## Hall effect thumbwheels

### CONFIGURATION OPTIONS

#### OPTIONS



OPTIONS AVAILABLE: BLACK, RED, BLUE AND GRAY WHEELS WITH OR WITHOUT CENTER TAB.

#### LINEAR OUTPUT OPTIONS

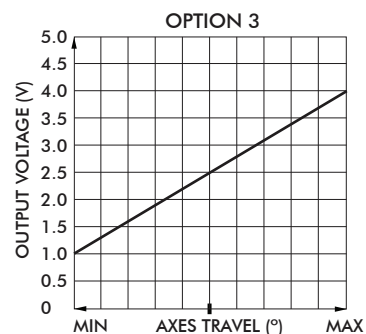
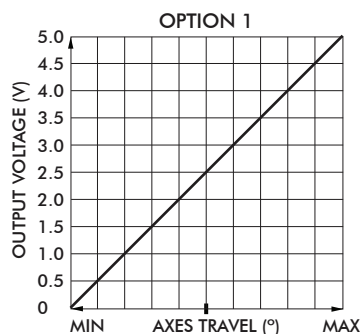

#### DEFAULT WIRE COLOR CODE

COLOR	FUNCTION	AWG
RED	+5V	28
BLACK	Ground	
BLUE	Output	

# 9000 series

Inductive sensing joysticks



The 9000 Series is ideal for those applications that demand proportional control with a low profile below the panel. Developed from the proven 7000 Series, the 9000 Series employs the same, highly proven, contactless, inductive sensing and circuitry. This joystick offers self-centering, omni-directional functionality, and utilizes the exclusive 'locking cam' system to rigidly secure the highly repeatable mechanism around the precision groundsteel operating shaft. High precision air wound coils are mounted directly onto the SMT circuitry, delivering enviable accuracy while further minimizing the installed depth of the joystick.



## KEY FEATURES

- One or two axes
- Signal mixing options
- 5 - 15V operation
- Optional "at center" and "internal fault" detection
- Dual redundant outputs.
- Infinite resolution
- Inductive sensing
- Consistent performance
- IP65 above panel
- Long service life
- Wide range of handles



# 9000 series

## Inductive sensing joysticks

### OPTION SELECTION

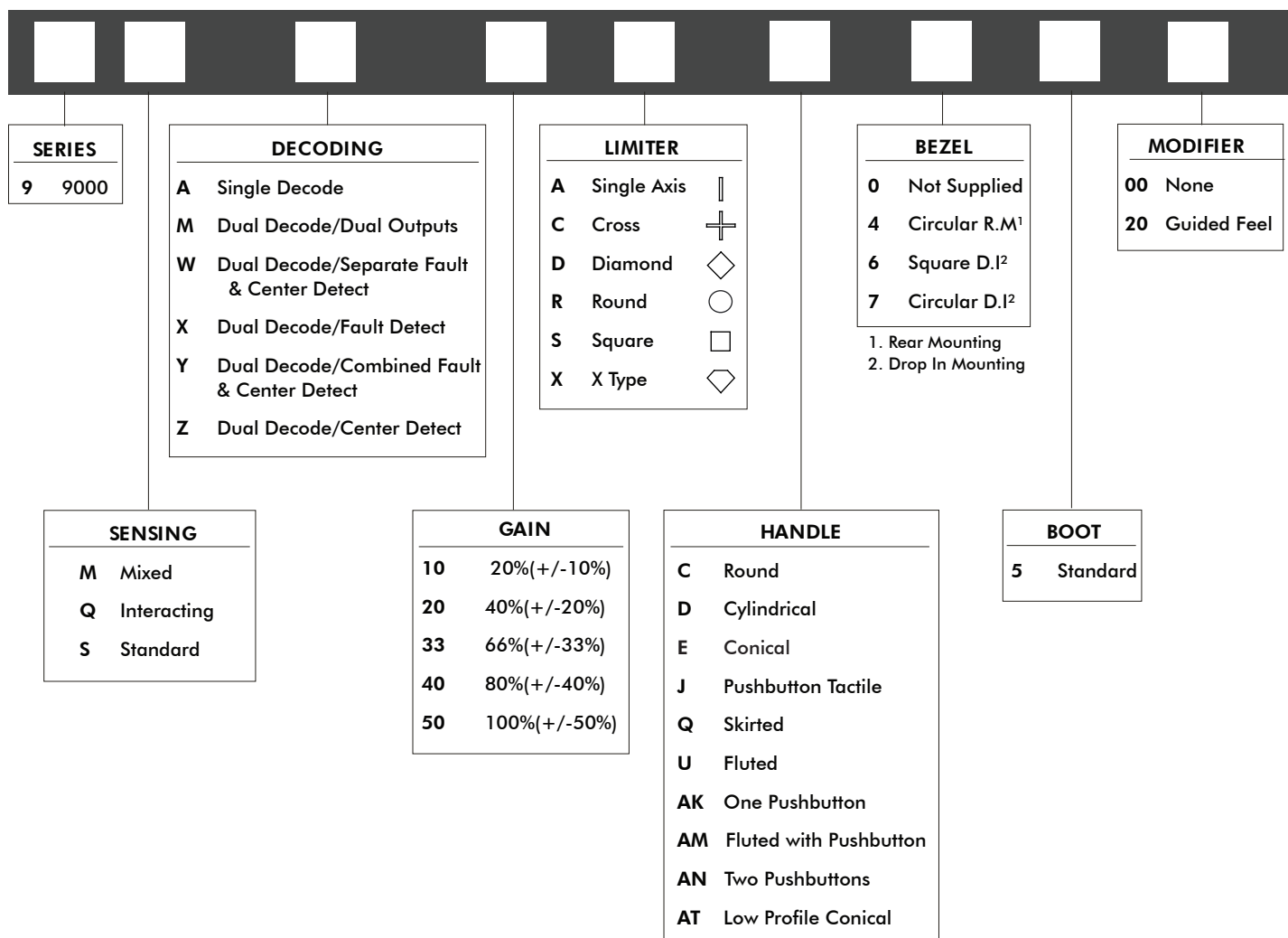

#### NOTES

##### 1. BEZEL OPTIONS

For drop in mounting, please specify bezel option 6 or 7. For sub-panel mounting, no bezel is necessary, unless the boot is required to seal to the front face of the panel in which case bezel option 4 should be specified. Bezels 6 & 7 clamp the boot and top face of the joystick body to the panel whereas bezel 4 clamps only the boot.

##### 2. SPRINGING

As standard 9000 Series are offered sprung to centre. The standard spring force requires 1.3N (nominally) to off-center the joystick. The 9000 Series may be specified with a lighter spring (1N), or a stronger spring (1.6N)

Note: Forces quoted are subject to exact joystick configuration and are provided as a guide only.

##### 3. DUAL DECODE INTERFACE

For optimum performance of the center detect and fault detect signals, Apem recommends the signals are "pulled high" via an input resistor of typically 22k, on the controller circuitry.

##### 4. CENTER TAP REFERENCE

All 9000 Series output a center tap reference as standard. This reference is set within the joystick at 50% of Vcc (+/-1%). For optimum accuracy the outputs should be read relative to the center tap.

##### 5. NON STANDARD

Further non standard options including custom handles or special limiters are available. Please refer to the factory for further details.

# 9000 series

## Inductive sensing joysticks

### TECHNICAL SPECIFICATIONS

Life Cycles	: > 10 Million Operations	Supply Voltage	: 4.75V Min to 15V Max
Signal Swing	: +/-10% of Vcc to +/-50% of Vcc	Output Signal Tolerance	: +/-10% of Output
Output at Center	: +/-1%	Output Impedance	: 1.8k +/-1%
Signal Ripple	: <1% of Output	Supply Current	: Typically 10mA
ESD Immunity	: >12KV - Correctly Installed	RFI Rejection	: >20V/m - Bare Joystick
RFI Rejection	: >40V/m - Correctly Installed	Preferred Load	: >10K
Body Material	: Glass Reinforced ABS	Shaft Material	: Stainless Steel
Shaft Diameter	: 5 mm	Other Materials	: Brass, Acetal, Nylon
Gimbal Pivot	: Acetal & Hardened Steel	Boot	: Neoprene
Weight	: 90 grams (0.20lb)	Above Panel Seal	: IP65
Temperature Range	: -20°C to +55°C (-4°F to +131°F)	Operating Lever Deflection	: +/-18°

### CABLE SPECIFICATIONS

14/0.12 - Fourteen strands of 0.12mm diameter tinned annealed copper wire PVC insulated to a nominal OD of 1mm			
Red	: +Vcc	Black	: 0V
Blue	: X Axis Wiper	Yellow	: Y Axis Wiper
Green	: Center Tap Reference		
Orange	: Center Detect, or Combined Fault & Center Detect	White	: Fault Detect
Brown	: Mirror of X Axis Wiper	Grey	: Mirror of Y Axis Wiper
7/0.127 - Seven strands of 0.127mm diameter tinned copper wire ETFE insulated, to a nominal OD of 0.7mm			
Orange	: Pushbutton		
All 9000 Series are supplied with 150mm of twisted cable harness, with tinned ends.			
Connectors may be fitted upon request.			

### NEAR EQUIVALENT CIRCUIT

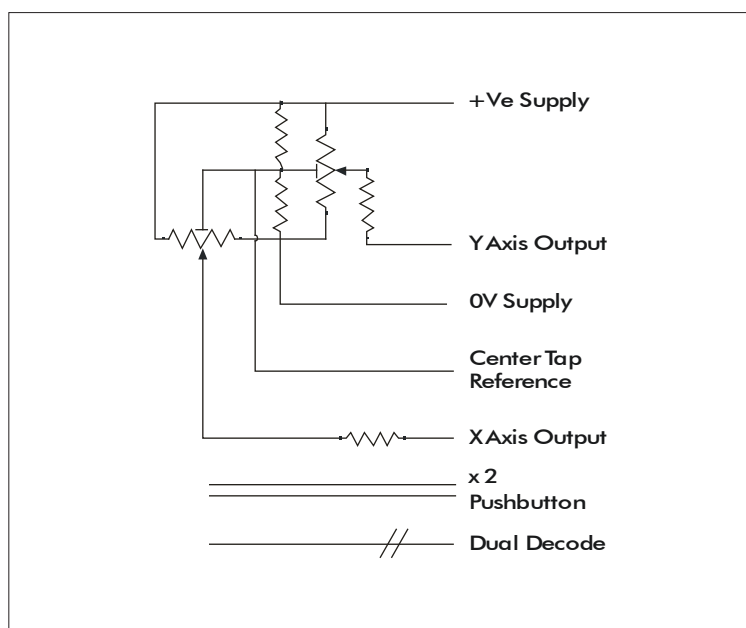

# 9000 series

## Inductive sensing joysticks

### DIMENSIONAL DRAWINGS - HANDLES

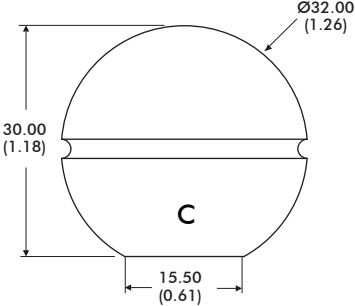
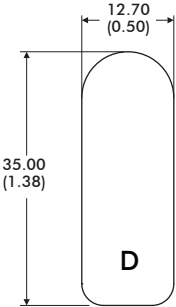
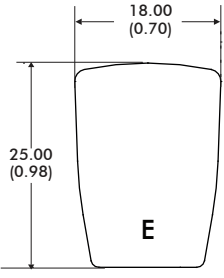
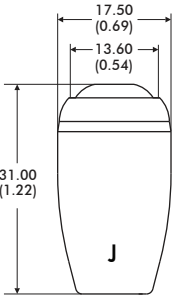
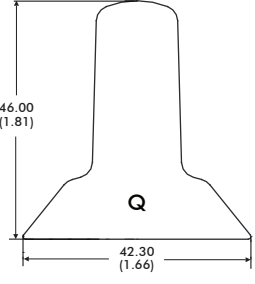
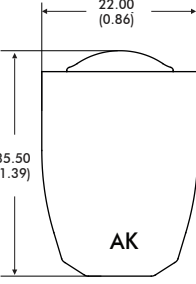
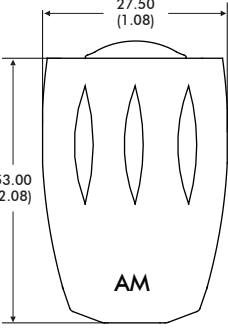
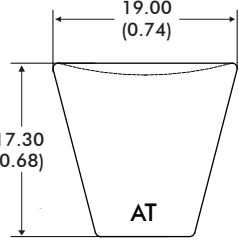
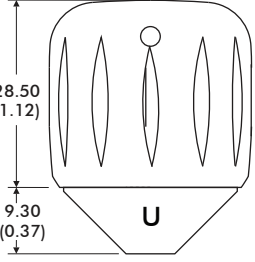
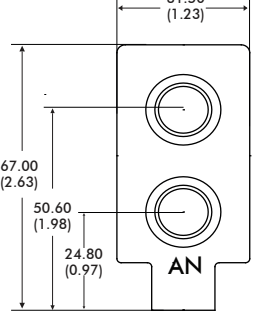
				
<p><b>MATERIAL</b> <b>FINISH</b> <b>STANDARD COLOR</b> <b>OTHER COLORS</b> <b>NOTES:</b></p>	<p>Phenolic Gloss Black Not Available</p>	<p>Aluminium Anodised Black Not available</p>	<p>Nylon Sparkled Matt Black Upon Request</p>	<p>ABS Sparkled Matt Black Upon Request Uses APEM IS Switch</p>
				
<p><b>MATERIAL</b> <b>FINISH</b> <b>STANDARD COLOR</b> <b>OTHER COLORS</b> <b>NOTES:</b></p>	<p>Nylon Sparkled Matt Black Upon Request</p>	<p>Aluminum Anodised Black Not Available Uses APEM IA Switch</p>	<p>Aluminium Anodised Black Upon Request Uses APEM IA Switch</p>	
				
<p><b>MATERIAL</b> <b>FINISH</b> <b>STANDARD COLOR</b> <b>OTHER COLORS</b> <b>NOTES:</b></p>	<p>Nylon Sparkled Matt Black Upon Request</p>	<p>Aluminum Anodised Black Not Available</p>	<p>Delrin Gloss Black Not Available Uses APEM IS Switch</p>	

1. Dimensions are in mm/(inch)



# 9000 series

## Inductive sensing joysticks

### DIMENSIONAL DRAWINGS - continued

#### GENERAL DIMENSIONS

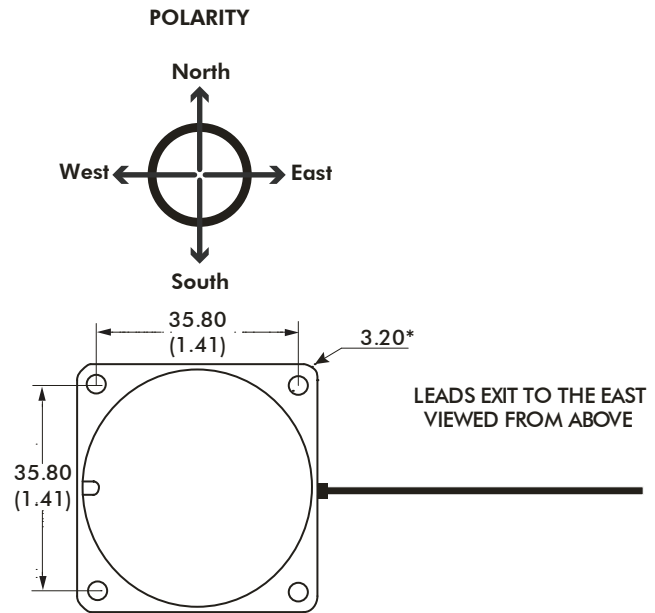
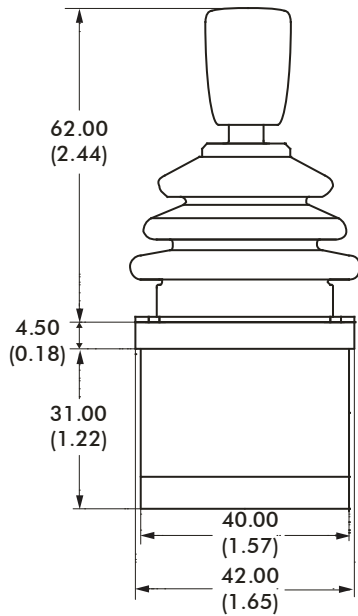

#### DROP IN MOUNTING - PANEL CUT-OUT & MOUNTING INSTALLATION

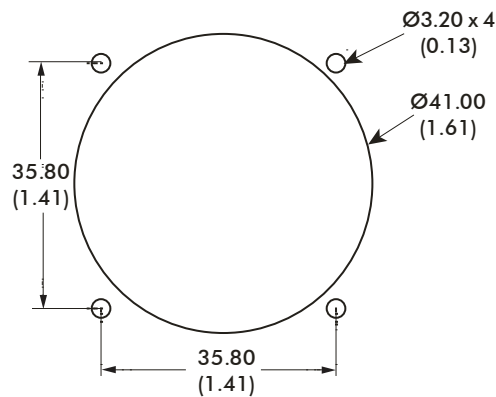
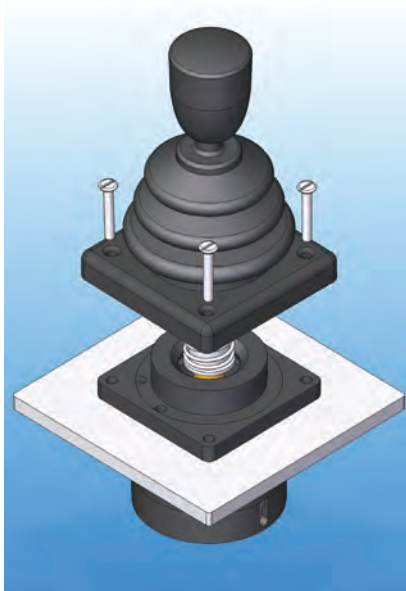

The joystick is dropped into the panel cut-out. The joystick and boot must be kept in place by bezel (option 6 & 7). For panel thickness of <3mm, M3 x 16 countersunk machine screws are recommended.

#### NOTES:

1. Dimensions are in mm/(inch)
2. The dimensions shown are for a generic 9000 Series with the conical E type handle. For specific dimensions of this or any other configuration please refer to the Factory.

# 9000 series

Inductive based joysticks

## MOUNTING OPTIONS

### MOUNTING OPTION A - PANEL CUT-OUT & MOUNTING INSTALLATION

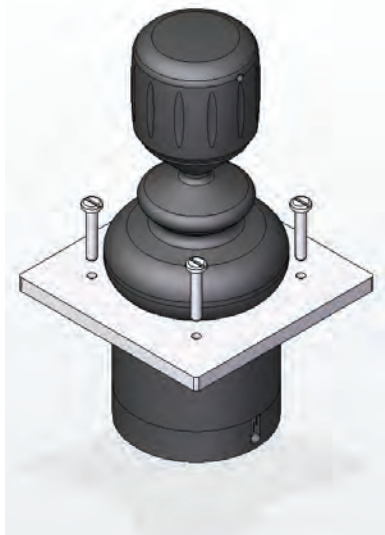

#### MOUNTING CUT-OUT

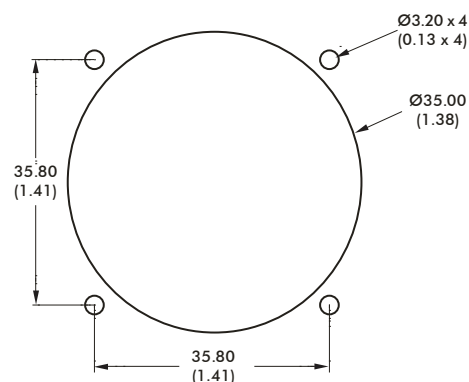

When mounted this way the panel acts as the bezel and no separate bezel is needed. M3 machine screws are recommended.

### MOUNTING OPTION B - PANEL CUT-OUT & MOUNTING INSTALLATION

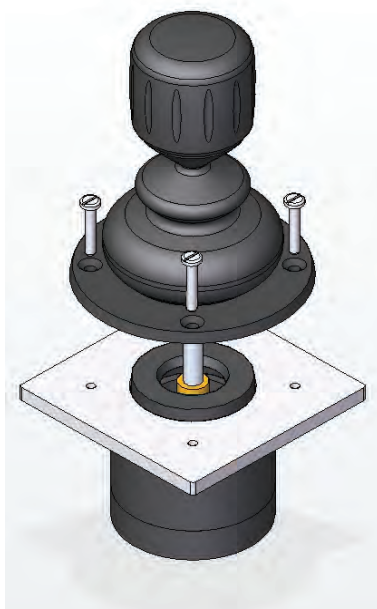

#### MOUNTING CUT-OUT

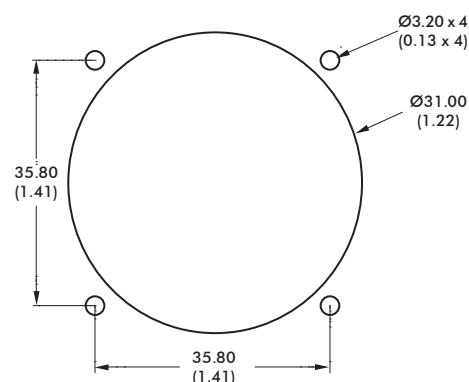

The joystick flange is mounted beneath the panel and the base of the boot must be brought through the panel cut-out and held in place with the circular bezel (option 4). For panel thicknesses of 3mm, M3 x 16 countersunk machine screws are recommended.

**NOTES:** Dimensions are in mm/(inch)

When sub panel mounting, great care should be taken not to damage the boot, or any of the mechanism under the boot. All panel cut-outs should be free from sharp edges and swarf that may damage the boot.

# 9000 series

Inductive sensing joysticks

CONFIGURATION OPTIONS

## CIRCUITRY

The 9000 Series joystick operates by passing an oscillating current through a drive coil, directly mounted at the lower end of the operating lever, and immediately above the four sensing coils. When the shaft and drive coil moves away from the centre, the signals detected in each opposing pair of coils increase nominally in proportion to deflection. The phase of those signals determine the direction. Synchronous electronic switches followed by integrating amplifiers provide DC signals directly equivalent to those of potentiometer joysticks, but with fixed output impedance and free of wiper noise and track wear.

## DUAL DECODE

Designed for use in the most safety-critical applications, the 9000 Series incorporates comprehensive internal monitoring circuitry whereby output signals are continually compared with separately generated 'mirror signals'. In the unlikely event of an internal fault, the dual decode system will generate a separate fault signal, enabling the controller to fail-to-safe. The dual decode system is a complete internal self-monitoring system, providing a far higher standard of protection. An additional, 'away from center' signal is also available whenever required. Although the monitoring of the joystick is fully internal, the inverse 'mirror signals' can be available as external outputs where the monitor function is incorporated within the controller circuitry.

## GUIDED FEEL

The 9000 Series may also be specified with guided feel. A joystick with guided feel moves more readily towards the poles ( N, S, E and W ) and while it can still move away from the poles, the force required to do so is greater. Unless specified otherwise, joysticks are supplied as standard without guiding. This standard configuration allows the user to move the joystick anywhere within the limiter with the same force and without any bias.

## FUNCTIONAL OPTIONS

The 9000 Series can be configured in three different modes:

**Orthogonal, standard signals** - Replicating that of a potentiometer.

**Deliberate signal mixing** - Ideal for those applications whereby the method of steering is by controlling two motors. For example one motor uses X+Y signals and the other uses X-Y signals. This mixing is achieved by internally orientating the signals at 45 degrees to normal. Typical applications may be twin propeller boats, tracked vehicles, or wheelchairs.

**Deliberate signal interaction** - Enables reduction in one signal as the other increases. This option is particularly beneficial where it is undesirable to maintain full forward speed while turning and vice versa.

## LINEAR OUTPUT OPTIONS

### SINGLE OUTPUT

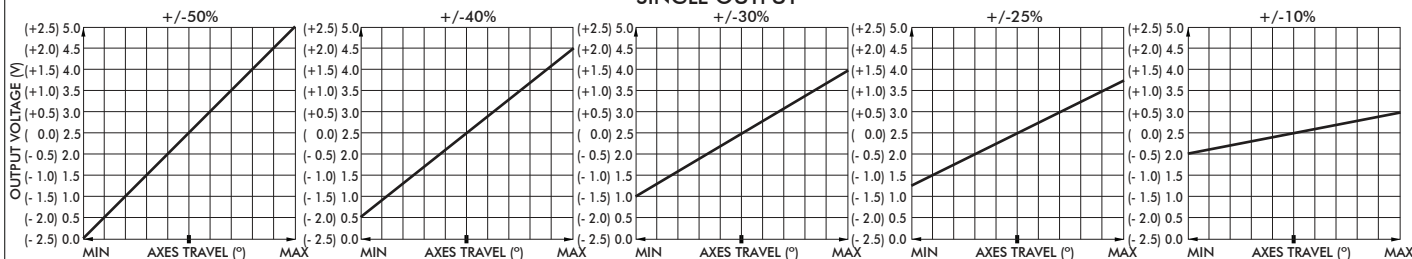

### DUAL OUTPUT

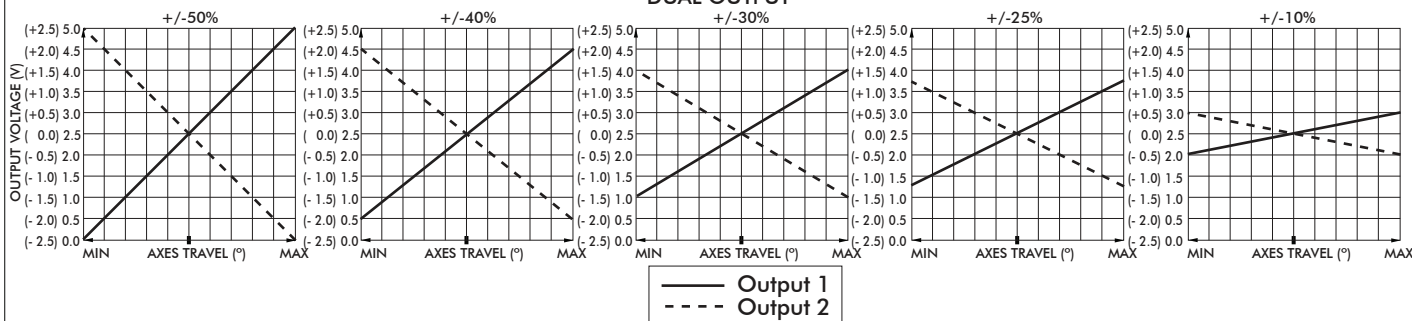

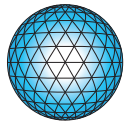

# APEM

## MS series

Mid-size Hall effect joysticks



The MS Series joystick is a contactless, Hall effect controller developed for demanding operator control applications requiring a rugged, yet compact hand-operated positioning device. Available with several ergonomic multi-axes handles while utilizing only five square inches of surface area, the MS Series joystick is ideally suited for off-highway enclosed cabin vehicles. Striking the perfect balance between size and durability, widely used applications include watercraft, agricultural, forestry, and material handling vehicles.

### KEY FEATURES

- Compact size**
- 1, 2 and 3 axes configurations**
- Available with J1939 CANbus**
- Available with USB**
- Redundant outputs available**
- 10 million life cycles**
- Sealed up to IP68**











# MS series

## Mid-size Hall effect joysticks

### OPTION SELECTION

MS					
<b>SERIES</b>	<b>FRONT BUTTONS</b>	<b>SIDE BUTTONS</b>	<b>SPRING TENSION<sup>3</sup></b>	<b>OUTPUT OPTIONS</b>	<b>ADDITIONAL OPTIONS</b>
	<b>N</b> None <b>O</b> One <b>W</b> Two	<b>0</b> None <b>U</b> One Upper Position <b>L</b> One Lower Position <b>F</b> Two <b>P</b> Proximity Sensor <b>D</b> Deadman	<b>00</b> Standard <b>01</b> Light <b>02</b> Heavy	<b>0</b> 0V to 5V (Rail to Rail) <b>1</b> 0.5V to 4.5V <b>2</b> 0.25V to 4.75V <b>3</b> 1V to 4V <b>4</b> 0V to 5V - Sensor 1 0V to 5V - Sensor 2 <b>5</b> 0.5V to 4.5V - Sensor 1 0.5V to 4.5V - Sensor 2 <b>6</b> 0.25V to 4.75V - Sensor 1 0.25V to 4.75V - Sensor 2 <b>7</b> 1V to 4V - Sensor 1 1V to 4V - Sensor 2 <b>8</b> 0V to 5V - Sensor 1 5V to 0V - Sensor 2 <b>9</b> 0.5V to 4.5V - Sensor 1 4.5V to 0.5V - Sensor 2 <b>10</b> 0.25V to 4.75V - Sensor 1 4.75V to 0.25V - Sensor 2 <b>11</b> 1V to 4V - Sensor 1 4V to 1V - Sensor 2 <b>0-D</b> Discrete <b>0-U</b> USB <b>1-J</b> Cursor Emulation <b>2-C</b> CANbus	<b>V</b> Voltage Regulator <b>D</b> Dual Decode <b>DC</b> Center Detect <b>AD</b> Analog Deadband <b>P</b> Proximity Sensor <b>E</b> Environmental Sealing*
<b>HANDLE</b>		<b>TOP BUTTONS</b>	<b>LIMITER PLATE</b>		
<b>10</b> Ball Tip <b>42</b> Stock Grip <b>31</b> Short Stock Grip <b>23</b> Low Profile <sup>1</sup> (2 Axes) <b>24</b> Low Profile <sup>1</sup> (3 Axes) <b>54</b> Low Profile <sup>1</sup> Square Front (2 Axes) <b>55</b> Low Profile <sup>1</sup> Square Front (3 Axes)		<b>0</b> None <b>1</b> One <b>2</b> Two	<b>S</b> Square  <b>R</b> Round  <b>X</b> Slotted  <b>Y</b> Slotted  <b>P</b> Plus  <b>D</b> Diamond 		

**NOTES:**

1. Low Profile handles are offered in two options:

Low Profile



Low Profile Square Front



- Dual Decode cannot be used with CANbus, USB, or Voltage Regulator.
- X/Y axes spring tension. Contact Technical Support for information on the best possible spring for your chosen configuration.



\*Environmental sealing level available up to IP68. Dependent upon handle configuration.



Mounting accessories. Standard hardware includes: 4 screws (6-32x7/8)



# MS series

## Mid-size Hall effect joysticks

### STANDARD CONFIGURATIONS

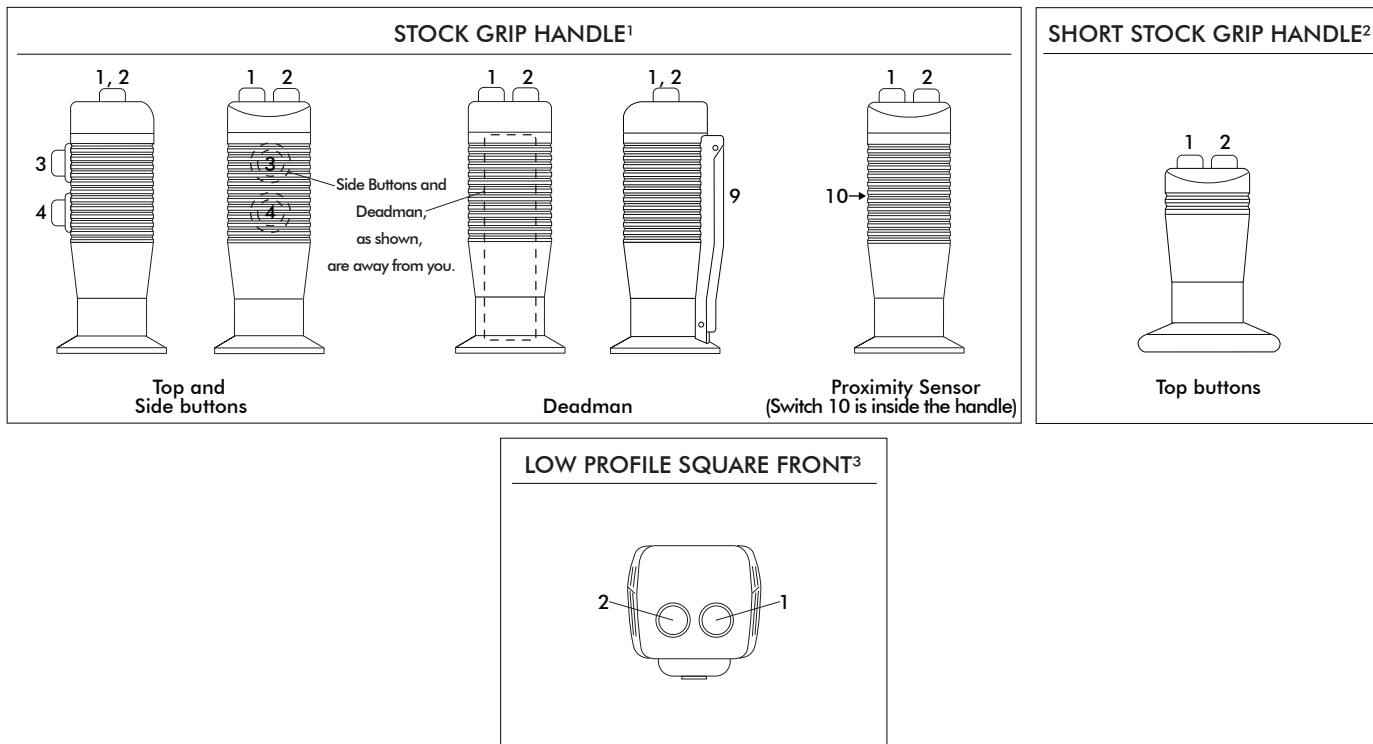

DEFAULT WIRE COLOR CODE*		
COLOR	FUNCTION	AWG
RED	Vcc or Vdd	28
BLACK	Ground	
BLUE	X Axis	
YELLOW	Y Axis	
GREEN	Z Axis	
WHITE	Switch Common (optional)	22
ORANGE	Switch 1 (optional)	
VIOLET	Switch 2 (optional)	
GRAY	Switch 3 (optional)	
BROWN	Switch 4 (optional)	
PINK	Switch 5 (optional)	
BLUE/WHITE	Switch 6 (optional)	
YELLOW/BLACK	Switch 7 (optional)	
GREEN/BLACK	Switch 8 (optional)	
VIOLET/WHITE	Deadman - Switch 9 (optional)	
YELLOW/WHITE	Proximity Sensor - Switch 10 (optional)	
RED/WHITE	Index Trigger - Switch 11 (optional)	
LIGHT GREEN	LED 12 (optional)	
LIGHT ORANGE	LED 13 (optional)	
GRAY/WHITE	LED 14 (optional)	
BLACK/WHITE	LED 15 (optional)	

AVAILABLE BUTTON COLORS	
	White
	Gray
	Black
	Red <sup>4</sup>
	Orange
	Yellow
	Green
	Blue
	Purple

\* - Starting from the strain relief, the cable is 406mm (16in) long, 6.40mm (0.25in) stripped with plug, covered with an expandable cable sleeve.

**NOTES:**

1. The maximum possible configuration for the Stock Grip handle is up to 2 Top Buttons and 2 Side Buttons. A handle with a Deadman or a Proximity Sensor can have 2 Top Buttons, but no Side Buttons.
2. The maximum possible configuration for the Short Stock Grip handle is up to 2 Top Buttons. It is not possible with Deadman, Index Trigger, Proximity Switch, or Side Buttons.
3. The maximum possible configuration for the Low Profile Square Front handle is up to 2 Front Buttons. It is not possible with Deadman, Index Trigger, Proximity Switch, or Top Buttons.
4. If unspecified, the pushbuttons will have snap action momentary switches with red button caps.

# MS series

## Mid-size Hall effect joysticks

### SPECIFICATIONS

#### MECHANICAL (FOR X AND Y AXES)

Break Out Force	-	5.6N (1.25lbf)
Operating Force	-	7.5N (1.70lbf)
Maximum Applied Force	-	650N (145lbf)
Mechanical Angle of Movement	-	40°
Expected Life	-	10 million cycles
Material	-	Glass reinforced nylon
Lever Action (Centering)	-	Spring centering

#### MECHANICAL (FOR Z AXIS)

Break Out Force	-	0.15N·m (1.33lbf-in)
Operating Force	-	0.25N·m (2.21lbf-in)
Maximum Allowable Force	-	4.50N·m (39.83lbf-in)
Hand Mechanical Angle	-	68°
Handle Action	-	Spring return
Expected Life	-	1 million cycles

#### ENVIRONMENTAL

Operating Temperature	-	-25°C to 70°C (-13°F to 158°F)
Storage Temperature	-	-40°C to 70°C (-40°F to 158°F)
Sealing (IP)	-	Up to IP68
EMC Immunity Level (V/M)	-	IEC 61000-4-3:2006
EMC Emissions Level	-	IEC 61000-4-8:2009
ESD	-	IEC 61000-4-2:2008

#### ELECTRICAL

Sensor	-	Hall effect
Resolution	-	Infinite
Supply Voltage Operating	-	5.00VDC
Reverse Polarity Max	-	-14.5VDC
Overvoltage Max	-	18VDC
Output Voltage	-	0V to 5V
Output Impedance	-	6Ω
Current Consumption Max	-	10mA max per axis
Return to Center Voltage (No Load)	-	±200mV

#### STANDARD SWITCH CHARACTERISTICS/RATINGS

Electrical Resistive Load:	-	5A
Electrical Inductive Load:	-	3A
DWV:	-	1050Vrms
Low Level:	-	10mA @ 30mV
Electrical Life:	-	25,000 cycles 5A @ 28VDC resistive snap-action
Mechanical Life:	-	1 million cycles
Environmental Seal:	-	IP67
Action:	-	Momentary, snap-action
Operating Force:	-	7.5N±2.0N (1.69lbf±0.45lbf)
Total Travel:	-	0.080 inches max
Over Travel:	-	0.010 inches min

#### CAN OUTPUT VERSION

Supply Voltage Range (Vdc)	-	6V to 40V
Can Version	-	J1939

#### NOTES:

- All values are nominal
- Exact specifications may be subject to configuration.
- Contact Technical Support for the performance of your specific configuration.

# MS series

## Mid-size Hall effect joysticks

### DIMENSIONAL DRAWINGS

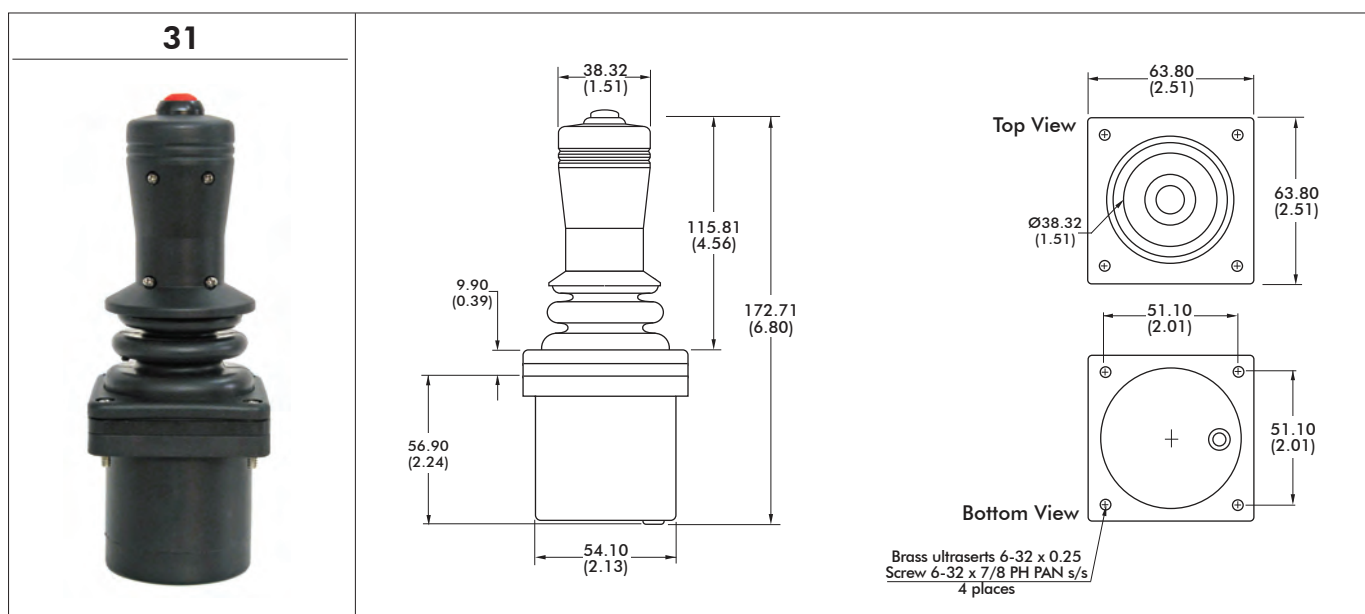
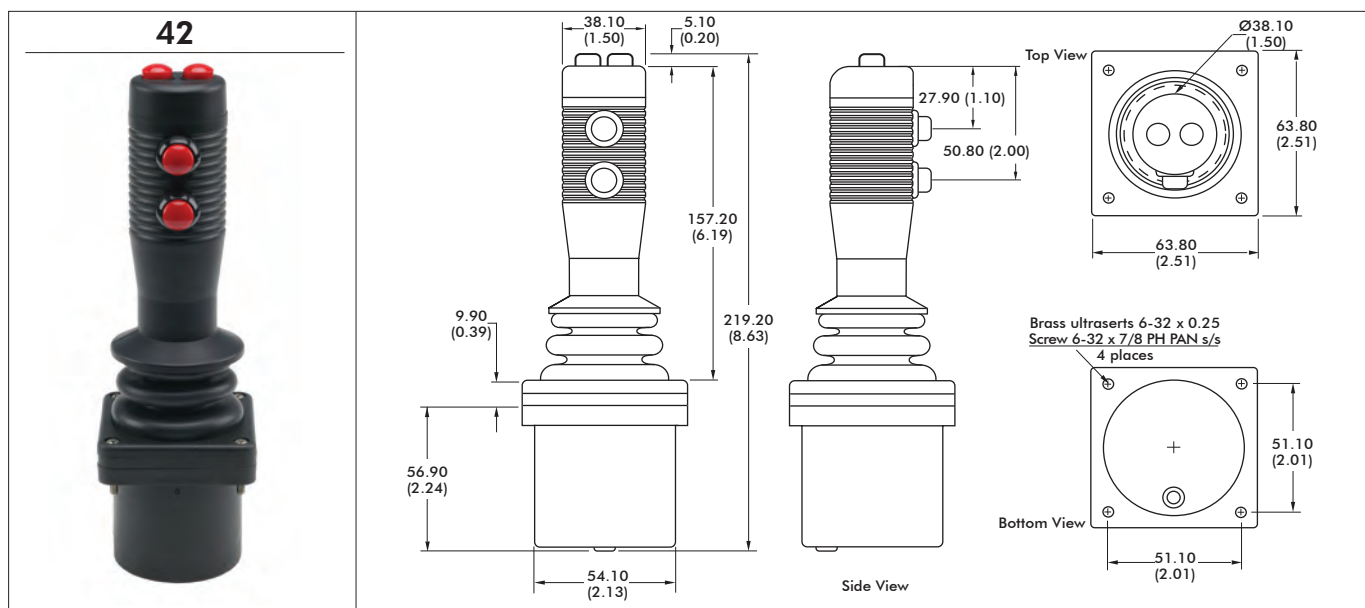
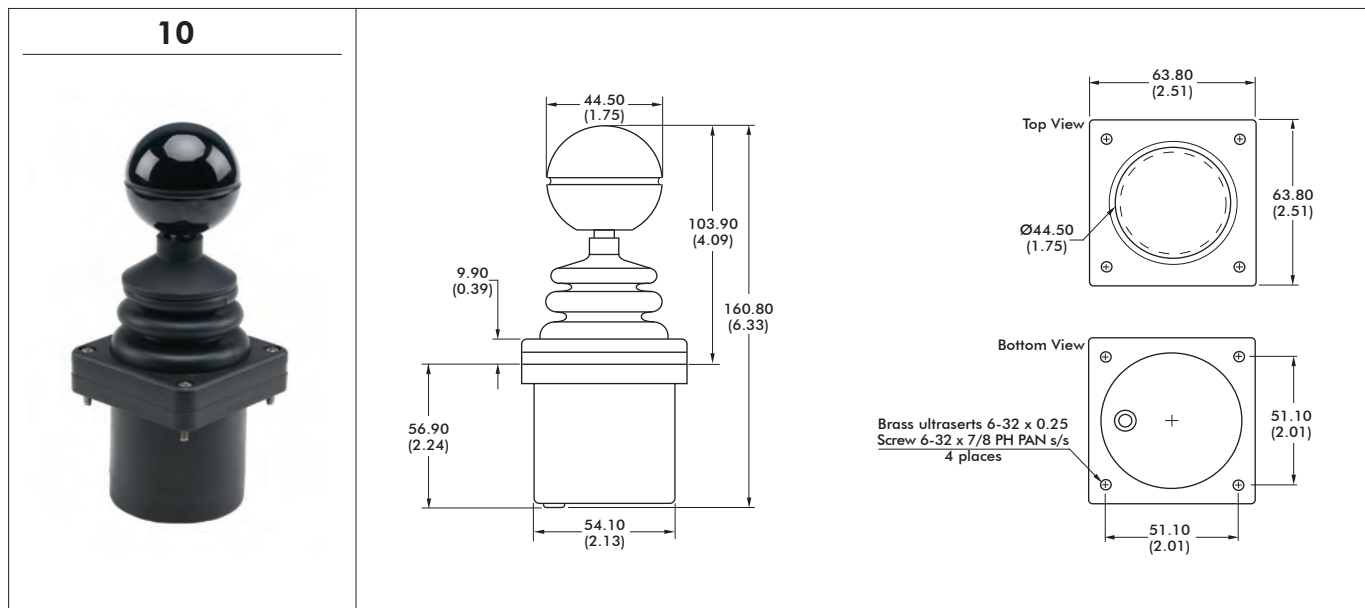

# MS series

## Mid-size Hall effect joysticks

### DIMENSIONAL DRAWINGS - continued

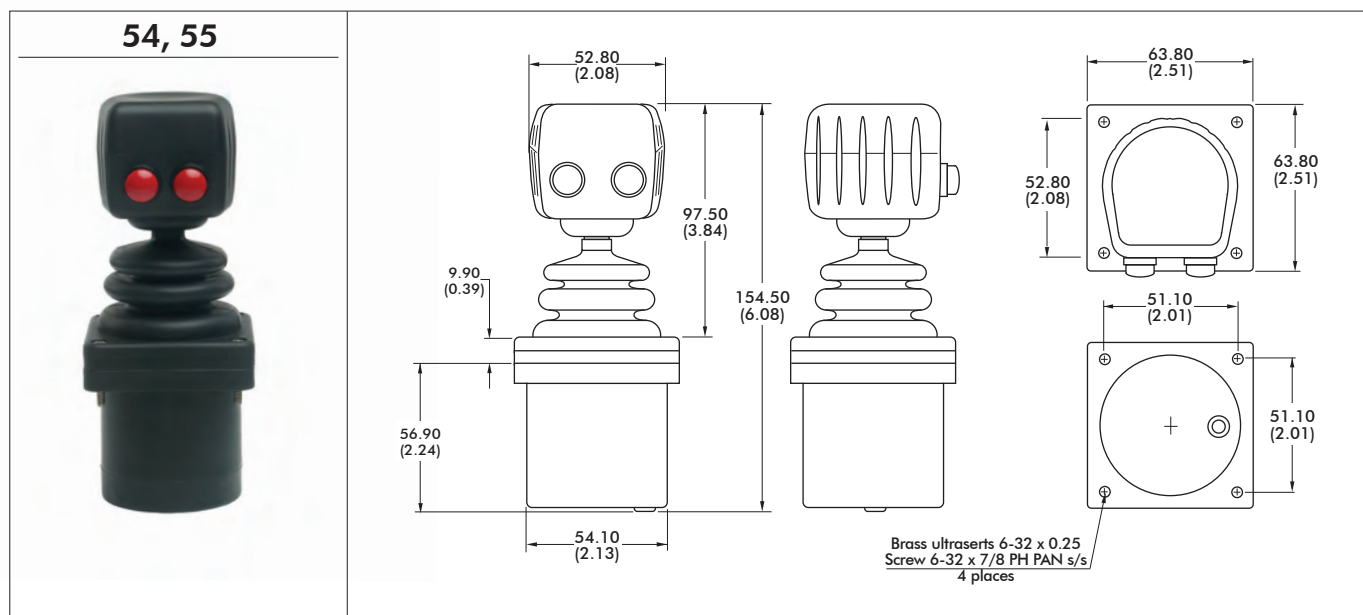
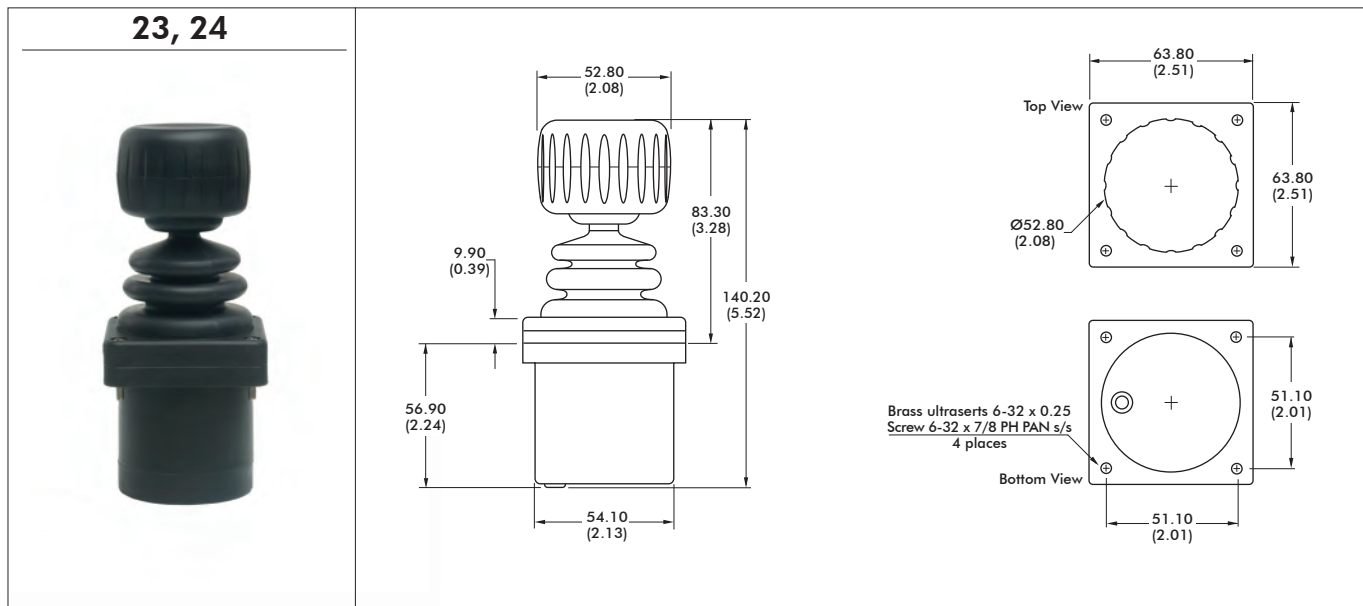

#### NOTES

1. Dimensions are in mm/(inch)
2. Standard configurations feature a rubber grommet as indicated in the above drawings. An optional plastic strain relief is available and will increase under panel mounting depth by 19.05 (0.75).
3. Actual strain relief position may vary
4. Axes orientation:

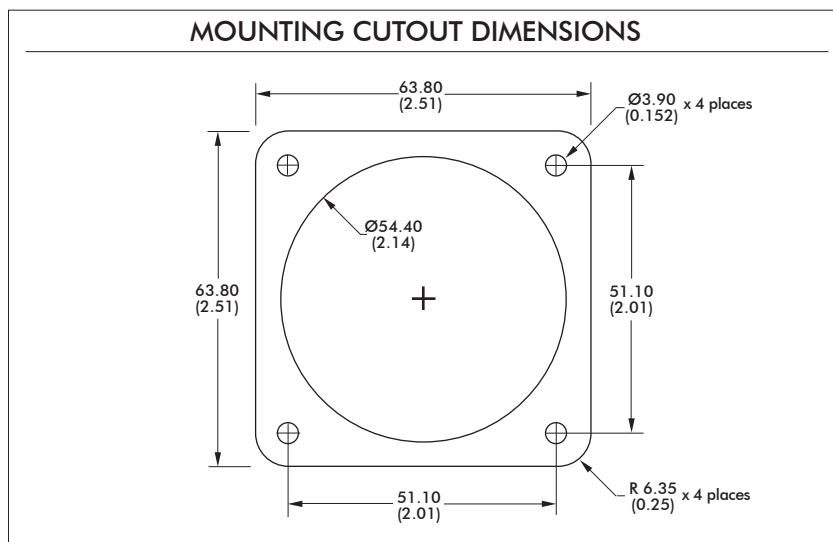
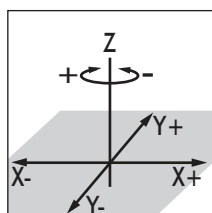

# MS series

## Mid-size Hall effect joysticks

### CONFIGURATION OPTIONS

#### LINEAR OUTPUT OPTIONS

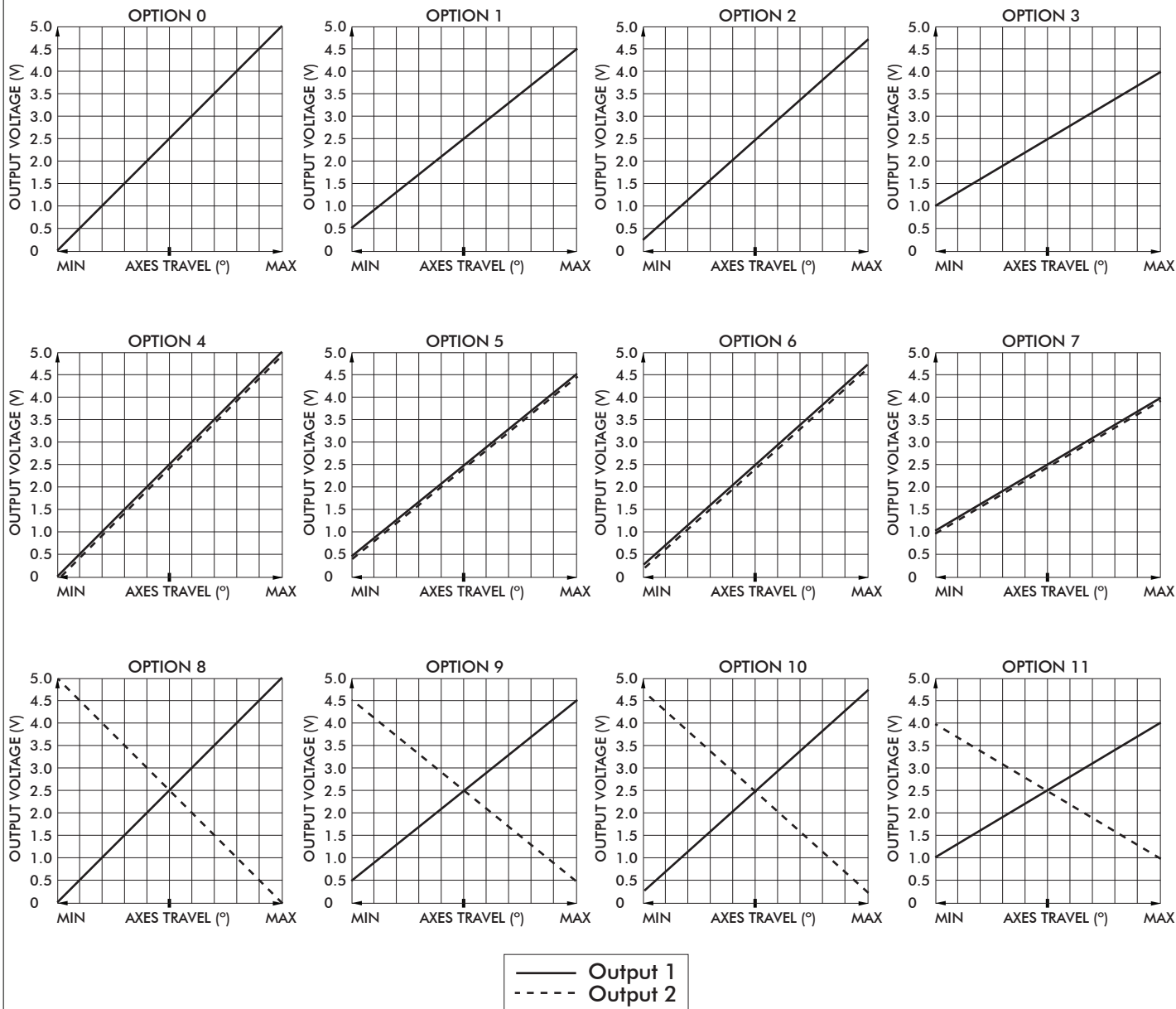



# MS series

## Mid-size Hall effect joysticks

### CONFIGURATION OPTIONS - continued

#### ADDITIONAL OUTPUT OPTIONS

### CANbus J1939

CH Products MS CANbus joysticks conform to the SAE J1939 serial bus specification used for communications between electronic control units and vehicle components.

#### FEATURES

- CANbus J1939
- Extended I/O extension for up to 16 digital and 3 analog inputs.
- Accommodates a 6-40VDC power supply

#### ELECTRICAL SPECIFICATIONS

Supply Power:	-	6 – 40 VDC
Supply Current:	-	15mA min, +5mA per LED, +6mA per axis

#### WIRING SPECIFICATION

Red Wire	-	Supply Power
Black Wire	-	Ground
Green Wire	-	CAN high data
White Wire	-	CAN low data
Blue Wire	-	Identifier Select
Orange Wire	-	Identifier Select

#### CONNECTOR OPTIONS:

- Cable assembly with Deutsch DT04 style plugs
- External I/O harnessing per customer specification

#### CANbus CONFIGURATION CHART

- Contact factory for assistance

BAUD RATE (Check one)		250K	500K	1000K		BLUE WIRE	ORANGE WIRE		
11 BIT IDENTIFIER (CAN2.0A) (Hex)	#1 TX	1	0			G	G		
	#2 TX						G		
	#3 TX					G			
	#4 TX								
29 BIT IDENTIFIER (CAN2.0B) (Hex)	#1 TX	3	2	1	0	G	G		
	#2 TX						G		
	#3 TX					G			
	#4 TX								
8 BYTE TX DATA FRAME (Binary)	7	6	5	4	3	2	1	0	IDENTIFIER SELECT WIRES
8 BYTE RX DATA FRAME (Binary)									(SUPPLIED IN PIGTAIL)
AXIS DATA TYPE (Check one)	SIGNED CHAR (+/-127)	UNSigned CHAR (0-255)	UNSigned INT (0-1023)	UNSigned INT (0-4095)					G-TIED TO 0V (BLACK WIRE)

# MS series

## Mid-size Hall effect joysticks

### CONFIGURATION OPTIONS - continued

#### ADDITIONAL OUTPUT OPTIONS

#### PLUG-AND-PLAY SOLUTIONS:

#### USB

Featuring USB 1.1 HID compliant interface, CH Products' USB joysticks are recognized as standard HID "game controller" devices. Adhering to the HID specification, CH Products' USB joysticks are plug-and-play with most versions of Windows and Linux. Joystick button and axes assignments are dependent upon the controlled application.

#### FEATURES

- USB 1.1 HID compliant "game controller" device
- Easy to install and operate
- Functions determined by controlled application
- Standard Male Type A Connector



USB Male Type A Connector

#### SUPPLIED WIRING

USB: USB Male Type A Connector with overmolded cable  
(Optional ruggedized military connectors are available.)

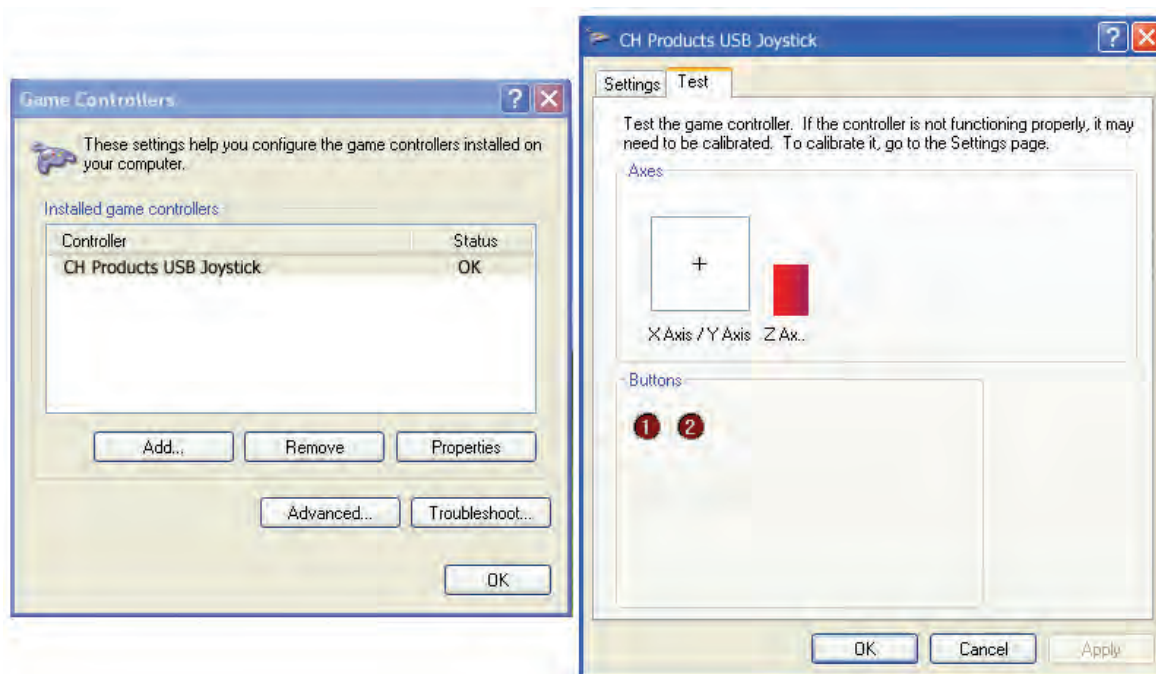

# MS series

## Mid-size Hall effect joysticks

### CONFIGURATION OPTIONS - continued

#### ADDITIONAL OUTPUT OPTIONS

#### PLUG-AND-PLAY SOLUTIONS:

#### JOYBALL (CURSOR EMULATION)

The Joyball option converts multi-axis joystick output into a mouse, trackball, or cursor control device. The joystick's internal microprocessor converts absolute axis position into a cursor velocity, which is translated as a relative trackball or mouse position. Supported protocols include Sun Microsystems (mouse systems 5vdc serial) and USB.

#### APPLICATIONS

The Joyball option is ideal for vehicle applications subjected to dirt and high vibration which makes operating a traditional cursor control device difficult. The Joyball option is widely used in shipboard and military applications.

#### FEATURES

- HID compliant "pointing device"
- Plug-and-play with USB option
- Ideal for marine GPS and navigation
- Environmental sealing up to IP68

#### SUPPLIED WIRING

USB: USB Male Type A Connector with overmolded cable

SUN: SUN mini-DIN plug with overmolded cable and strain relief

#### I/O COMPLEMENT/ USER SPECIFIED PARAMETERS:

- USB 4 pushbuttons 2 or 3 axes (X, Y, and Z "scroll")
- SUN 2 pushbuttons and 2 axes (X, Y)

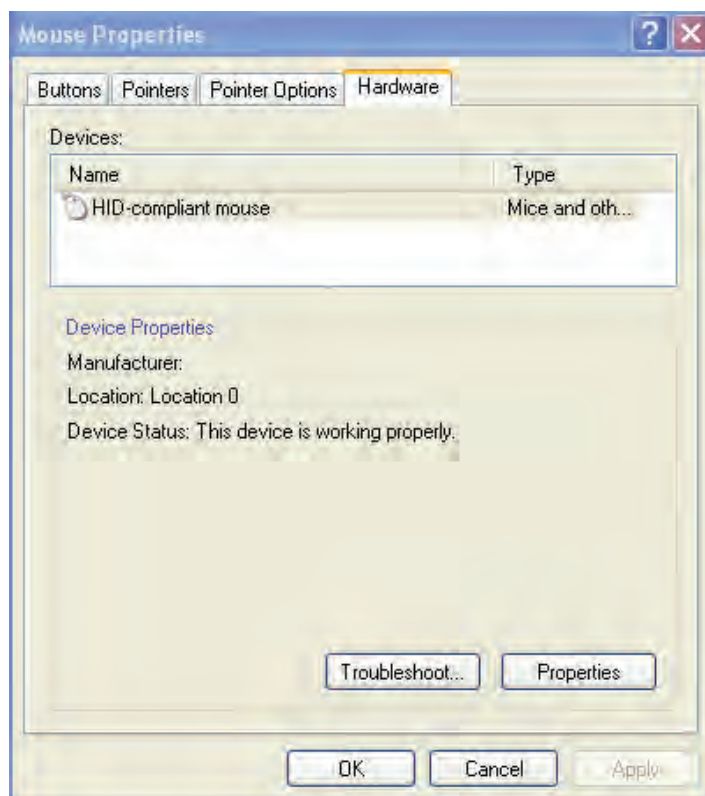

# MS series

## Mid-size Hall effect joysticks

### CONFIGURATION OPTIONS - continued

#### ADDITIONAL OUTPUT OPTIONS

### DUAL DECODE

Dual Decode utilizes a microprocessor to monitor two linear opposite-ramp signals for each joystick axis and provides one proportional (0.5VDC – 4.5VDC) and one logical output accordingly. The dual inverted signals are continuously monitored and a logical signal of 0VDC is provided for over-range (>4.5VDC), under-range (<0.5VDC) and signal tracking (sum of both signals equals 4.5V +/-10%) error. A logical signal of 5.0VDC is provided for a properly functioning joystick deflected from center.

#### APPLICATIONS

Dual Decode provides a center detect function as well as error tracking, making it ideal for high liability, safety critical applications.

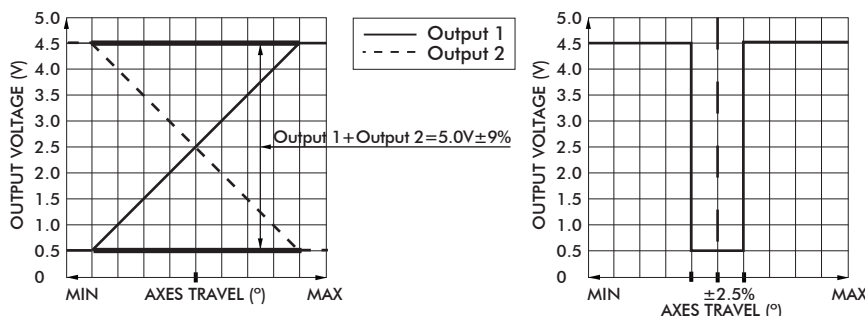

#### ELECTRICAL SPECIFICATIONS

Supply Power	-	4.5VDC to 5.5VDC
Supply Current	-	30mA + 10mA per axis

#### WIRING SPECIFICATION

Red wire	-	Customer power supply 4.5VDC-5.5VDC
Black wire	-	Ground
Blue wire	-	X axis output
Yellow wire	-	Y axis output
Green wire	-	Z axis output
Blue/White wire	-	X axis dual decode logic output
Yellow/Black wire	-	Y axis dual decode logic output
Green/Black wire	-	Z axis dual decode logic output
White wire	-	Pushbutton common wire
Orange,violet,gray,brown,pink,bl/wt/y/bk,gn/bk,gy/w wire	-	Pushbutton outputs

### ANALOG DEADBAND

Analog Deadband utilizes an analog circuit to monitor proportional joystick outputs and enhance return to center accuracy over multiple axes. Specified for joysticks with normally ranged outputs of 0VDC – 5VDC at full axis travel, a constant output of 2.5VDC is provided for the joystick's position +/-2.5° from center.

#### APPLICATIONS

Analog Deadband effectively eliminates mechanical return-to-center error, making it ideally suited for safety critical applications susceptible to drift and motion control systems lacking center position trim.

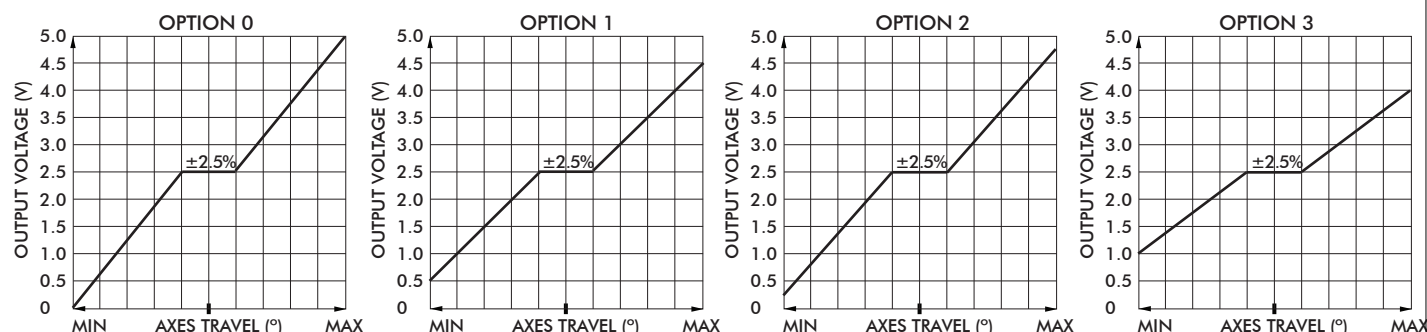

# MS series

## Mid-size Hall effect joysticks

### CONFIGURATION OPTIONS - continued

#### ADDITIONAL OUTPUT OPTIONS

ELECTRICAL SPECIFICATIONS		
Supply Power	-	4.5VDC to 5.5VDC
Supply Current	-	10mA per axis

WIRING SPECIFICATION		
Red wire	-	Customer power supply 4.5-5.5vdc
Black wire	-	Ground
Blue wire	-	X axis output
Yellow wire	-	Y axis output
Green wire	-	Z axis output
White wire	-	Pushbutton common wire
Orange,violet,gray,brown,pink,bl/wt/y/bk,gn/bk,gy/w wire	-	Pushbutton outputs

### CENTER DETECT

Center Detect utilizes a microprocessor to monitor joystick output and provides both logic and proportional signals for enhanced operator safety. Specified for a joystick normally ranged 0.5VDC to 4.5VDC, the microprocessor continuously monitors the proportional output and provides HI logic signal (5.0VDC) when moved off center and a LO logical signal (0VDC) for an over-range (>4.5VDC) or under-range (<0.5VDC).

### APPLICATIONS

Center Detect is ideal for safety critical applications including master relay control "MRC" for a motion control system or as a brake release for an overhauling load.

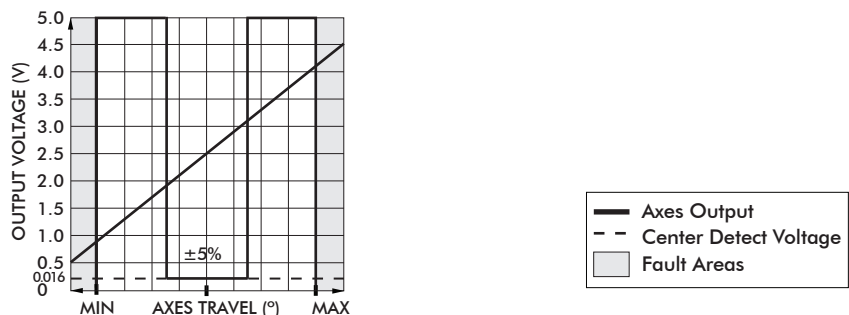

ELECTRICAL SPECIFICATIONS		
Supply Power	-	4.5V to 5.5V
Supply Current	-	30mA + 10mA per axis

WIRING SPECIFICATION		
Red Wire	-	Power supply 4.5 - 5.5VDC
Black Wire	-	Ground
Blue Wire	-	X axis output
Yellow Wire	-	Y axis output
Green Wire	-	Z axis output
Blue/White Wire	-	X axis center detect logic output
Yellow/Black Wire	-	Y axis center detect logic output
Green/Black Wire	-	Z axis center detect logic output
White Wire	-	Pushbutton common wire
Orange,violet,gray,brown,pink,bl/wt/y/bk,gn/bk,gy/w wire	-	Pushbutton outputs



# MS series

Mid-size Hall effect joysticks

CONFIGURATION OPTIONS - continued

## ADDITIONAL OUTPUT OPTIONS

### DISCRETE OUTPUT

Discrete Output is a microprocessor based option that provides up to six hi voltage/hi current, on/off outputs as well as proportional signals. Featuring a microcontroller, an a/d converter, and four to eight optically isolated solid state switches, the Discrete Output provides an electronic "switch stick" function. Switch combinations and firing angles are programmed to the application's requirement.

#### APPLICATIONS

The Discrete Output option is designed for small motor, reversing starters or hydraulic solenoid actuations.

#### DC SPECIFICATIONS

Supply Voltage Operating	-	5.0- 40VDC input power
Supply Current	-	30mA + 10mA per Hall sensor
Sourcing Outputs	-	70V AC/DC @ 1.6A max.
Sinking Outputs	-	70V AC/DC @ 3.6A max.
Discrete Output Max	-	60VDC/AC, 3.2A per discrete output

#### WIRING

Red Wire	-	Customer power supply 5 - 40VDC
Black Wire	-	Customer power supply ground
Blue Wire	-	X axis output
Yellow Wire	-	Y axis output
Green Wire	-	Z axis output
Blue/White Wire	-	X axis discrete output
Yellow/Black Wire	-	Y axis discrete output
Green/Black Wire	-	Z axis discrete output
White Wire	-	Pushbutton common wire
Orange,violet,gray,brown,pink,bl/wt,y/bk,gn/bk,gy/w wire	-	Pushbutton outputs

#### I/O COMPLEMENT AND USER SPECIFIED PARAMETERS:

Up to three axes and six discrete sourcing or sinking outputs.

#### DISCRETE OUTPUT CONFIGURATION FORM:

Discrete Output	Sourcing	Sinking	AC	DC
Xfwd				
Xrev				
Yfwd				
Yrev				
Zfwd				
Zrev				

#### SAMPLE OF COMPLETED FORM:

(Please enter required choices for each applicable axis and return form to factory.)

Discrete Output	Sourcing	Sinking	AC	DC
Xfwd		X		X
Xrev		X		X
Yfwd	X			X
Yrev	X			X
Zfwd		X		X
Zrev		X		X

# MS series

## Mid-size Hall effect joysticks

### CONFIGURATION OPTIONS - continued

#### ADDITIONAL OUTPUT OPTIONS

#### VOLTAGE REGULATOR

The Voltage Regulator is a multi-wired analog option used to mate to a variety of industrial control voltages. The Voltage Regulator may be used when the supply or output voltage is greater than 5V or when bipolar output is required.

User Specified Supply Voltage:

- 5 VDC
- 10 VDC
- 12 VDC
- 24 – 30 VDC
- Custom supply options available.

User Specified Output Voltage:

- 0-5 VDC
- 0-10 VDC
- +/-5 VDC
- +/-10 VDC
- Custom outputs available.

#### ELECTRICAL SPECIFICATIONS

Supply Power	-	5VDC to 30VDC
Supply Current	-	90mA max

#### WIRING SPECIFICATION

Red wire	-	Supply power 5-30VDC
Black wire	-	Ground
Blue wire	-	X axis output
Yellow wire	-	Y axis output
Green wire	-	Z axis output
White wire	-	Pushbutton common wire
Orange,violet,grey,brown,pink,bl/wt/y/bk,gn/bk,gy/w wire	-	Pushbutton outputs





# HG series

Hand grip Hall effect joysticks



The HG Series joystick is a rugged Hall effect controller designed for use in high operating force, hand-operated applications requiring reliable positioning control. Available with several high-function handles and in single, dual or triple axes configurations, HG Series joysticks are custom configured to meet the exacting requirements of harsh applications. Typical applications include military vehicles, refuse handling trucks, as well as fire and off-highway vehicles.

## KEY FEATURES

- Rugged, hand operation
- Hall effect sensing
- Sealed up to IP68
- 10 million life cycles
- Redundant output available
- Analog, CANbus, USB and custom outputs available



# HG series

## Hand grip Hall effect joysticks

### OPTION SELECTION

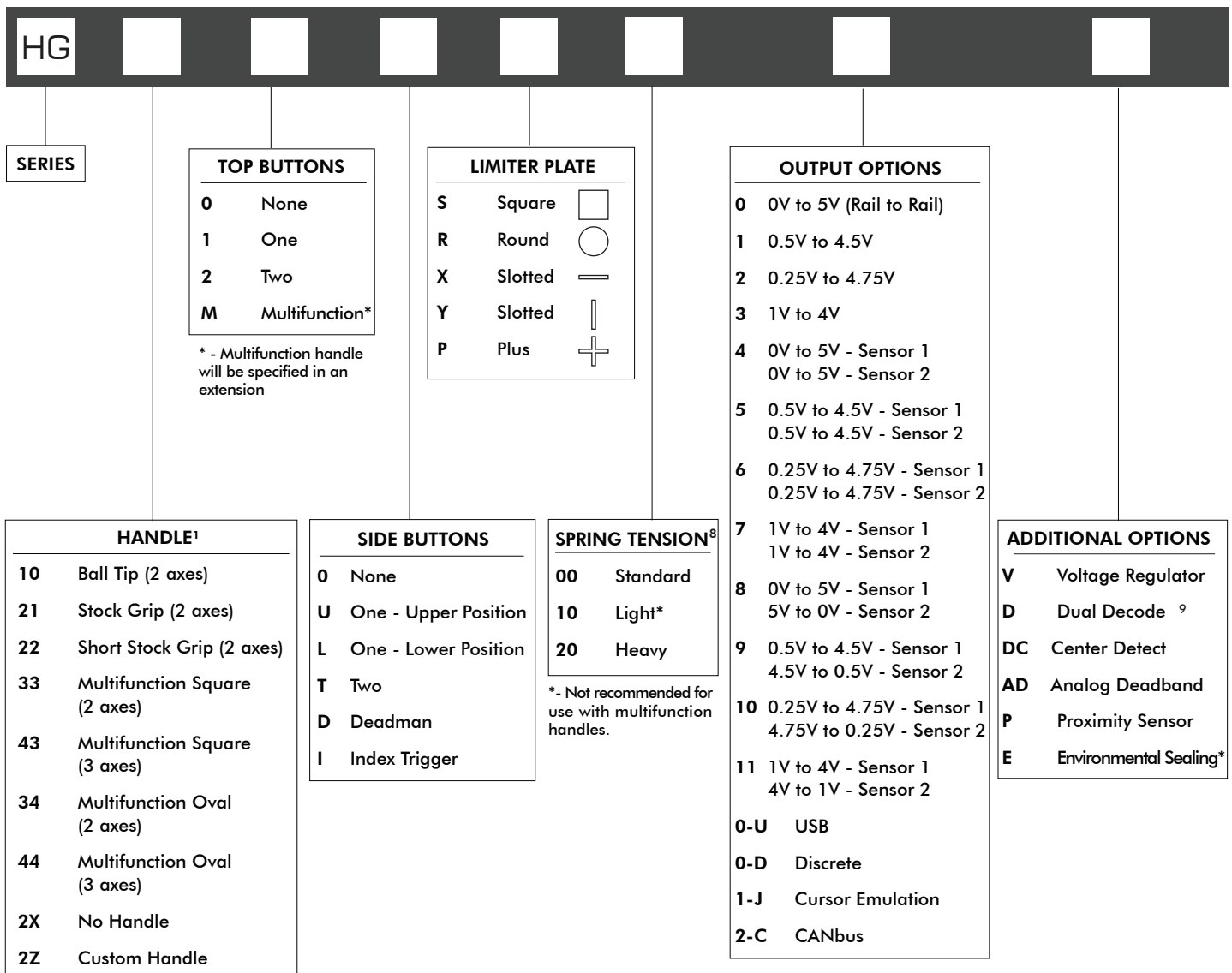

**NOTES:**

1. Refer to next page for information on standard configurations for joysticks with Stock Grip, Short Stock Grip, and Multifunction handles.
2. Stock Grip handles can have either a Deadman or a Proximity Switch.
3. Multifunction handles can have either an Index Trigger or a Proximity Switch.
4. When ordering the multifunction handle, specify Square or Oval.
5. Multifunction handle orders should be accompanied by drawing of button/component placement.
6. Multifunction handle requires Drop-in mounting.
7. Option 2X (no handle) and Option 2Z (custom handle) may require discussion with Technical Support.
8. X/Y axes spring tension. Contact Technical Support for information on best possible spring for your chosen configuration.
9. Dual Decode cannot be used with CANbus, USB, or Voltage Regulator.



\*Environmental sealing level available up to IP68. Dependent upon handle configuration.



Mounting accessories. Standard hardware includes: 1 gasket, 4 nuts (1/4-20), 4 washers (1/4), 4 screws (1/4-20x1 1/4)



# HG series

## Hand grip Hall effect joysticks

### STANDARD CONFIGURATIONS

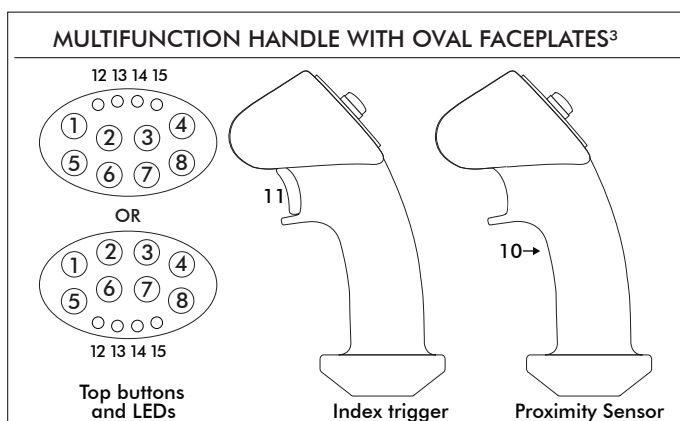
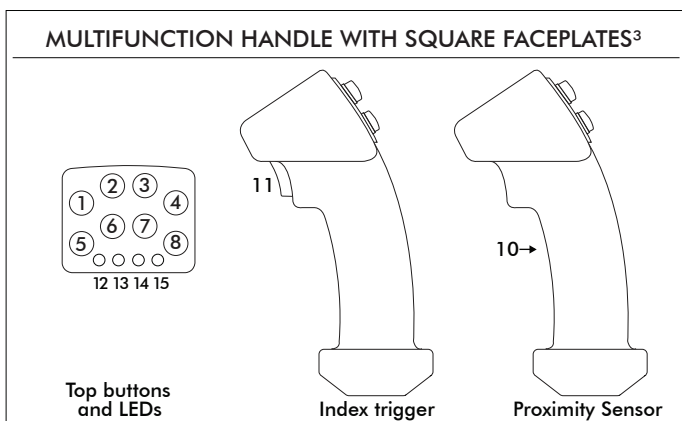
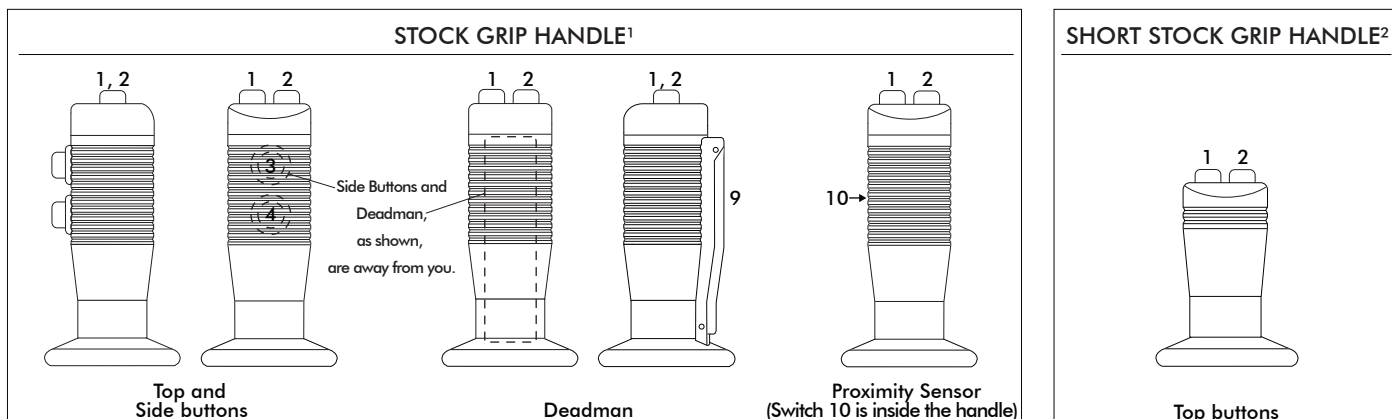

DEFAULT WIRE COLOR CODE*		
COLOR	FUNCTION	AWG
RED	Vcc or Vdd	28
BLACK	Ground	
BLUE	X Axis	
YELLOW	Y Axis	
GREEN	Z Axis	
WHITE	Switch Common (optional)	22
ORANGE	Switch 1 (optional)	
VIOLET	Switch 2 (optional)	
GRAY	Switch 3 (optional)	
BROWN	Switch 4 (optional)	
PINK	Switch 5 (optional)	
BLUE/WHITE	Switch 6 (optional)	
YELLOW/BLACK	Switch 7 (optional)	
GREEN/BLACK	Switch 8 (optional)	
VIOLET/WHITE	Deadman - Switch 9 (optional)	
YELLOW/WHITE	Proximity Sensor - Switch 10 (optional)	
RED/WHITE	Index Trigger - Switch 11 (optional)	
LIGHT GREEN	LED - 12 (optional)	
LIGHT ORANGE	LED - 13 (optional)	
GRAY/WHITE	LED - 14 (optional)	
BLACK/WHITE	LED - 15 (optional)	

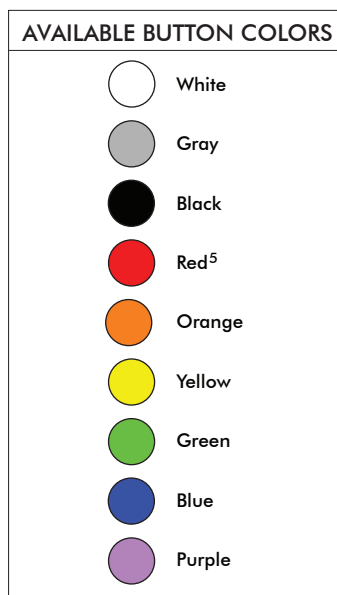

**NOTES:**

\* - Starting from the stain relief, the cable is 406mm (16in) long, 6.40mm (0.25in) stripped with plug, covered with an expandable cable sleeve.

1. The maximum possible configuration for the Stock Grip handle is up to 2 Top Buttons and 2 Side Buttons. A handle with a Deadman or a Proximity Sensor can have 2 Top Buttons, but no Side Buttons.
2. The maximum possible configuration for the Short Stock Grip handle is up to 2 Top Buttons. It is not possible with Deadman, Index Trigger, Proximity Switch, or Side Buttons.
3. A Multifunction handle can have a maximum of 8 Top Buttons and 4 LEDs on the faceplate, and an Index Trigger or a Proximity Sensor.
4. For non-standard configurations contact Technical Support. We can customize the faceplate according to your exact needs. For faceplate examples, see next page.
5. If unspecified, the pushbuttons will have snap action momentary switches with red button caps.
6. Switches will always be wired according to the position number on the handle and the Default Wire Color Code.



# HG series

Hand grip Hall effect joysticks

FACEPLATE EXAMPLES

## OVAL



1



2



3



4



5



6



7



8



9

## SQUARE



10



11



12



13



14



15



16



17

**HG series**

## Hand grip Hall effect joysticks

## SPECIFICATIONS

## MECHANICAL (FOR X AND Y AXES)

Break Out Force	-	7.7N (1.70lbf)
Operating Force	-	14.0N (3.10lbf)
Maximum Applied Force	-	1000.0N (225.00lbf)
Mechanical Angle of Movement	-	38°
Expected Life	-	10 million cycles
Lever Action (Centering)	-	Spring centering
Material	-	Glass reinforced nylon

## MECHANICAL (FOR Z AXIS)

Break Out Torque	-	0.6N·m (5.31lbf-in)
Operating Torque	-	1.1N·m (9.74lbf-in)
Maximum Allowable Torque	-	24.5N·m (216.84lbf-in)
Hand Mechanical Angle	-	42°
Expected Life	-	10 million cycles

## ENVIRONMENTAL

Operating Temperature	-	-25°C to 70°C (-13°F to 158°F)
Storage Temperature	-	-40°C to 70°C (-40°F to 158°F)
Sealing	-	IP65 to IP68 <sup>1</sup>
EMC Immunity Level (V/M)	-	IEC 61000-4-8:2009
EMC Emissions Level	-	IEC 61000-4-3:2006
ESD	-	IEC 61000-4-2:2008

## ELECTRICAL

Sensor	-	Hall effect
Resolution	-	Infinite
Supply Voltage Operating	-	5.00VDC
Reverse Polarity Max	-	-14.5VDC
Overvoltage Max	-	18VDC
Output Voltage	-	0.34V - 4.65V
Output Impedance	-	6Ω
Current Consumption Max	-	10mA max per axis
Return to Center Voltage (No Load)	-	±200mV

## STANDARD SWITCH CHARACTERISTICS/RATINGS

Electrical Resistive Load:	-	5A
Electrical Inductive Load:	-	3A
DWV:	-	1050Vrms
Low Level:	-	10mA @ 30mV
Electrical Life:	-	25,000 cycles 5A @ 28VDC resistive snap-action
Mechanical Life:	-	1 million cycles
Environmental Seal:	-	IP67
Action:	-	Momentary, snap-action
Operating Force:	-	7.5N±2.0N (1.69lbf±0.45lbf)
Total Travel:	-	0.080 inches max
Over Travel:	-	0.010 inches min

## CANbus OUTPUT VERSION

Supply Voltage Range	-	6V to 40V
CANbus Version	-	J1939

## NOTES:

- All values are nominal
- Exact specifications may be subject to configuration.  
Contact Technical Support for the performance of your specific configuration.
- <sup>1</sup> Excludes some handle options.

# HG series

## Hand grip Hall effect joysticks

### DIMENSIONAL DRAWINGS

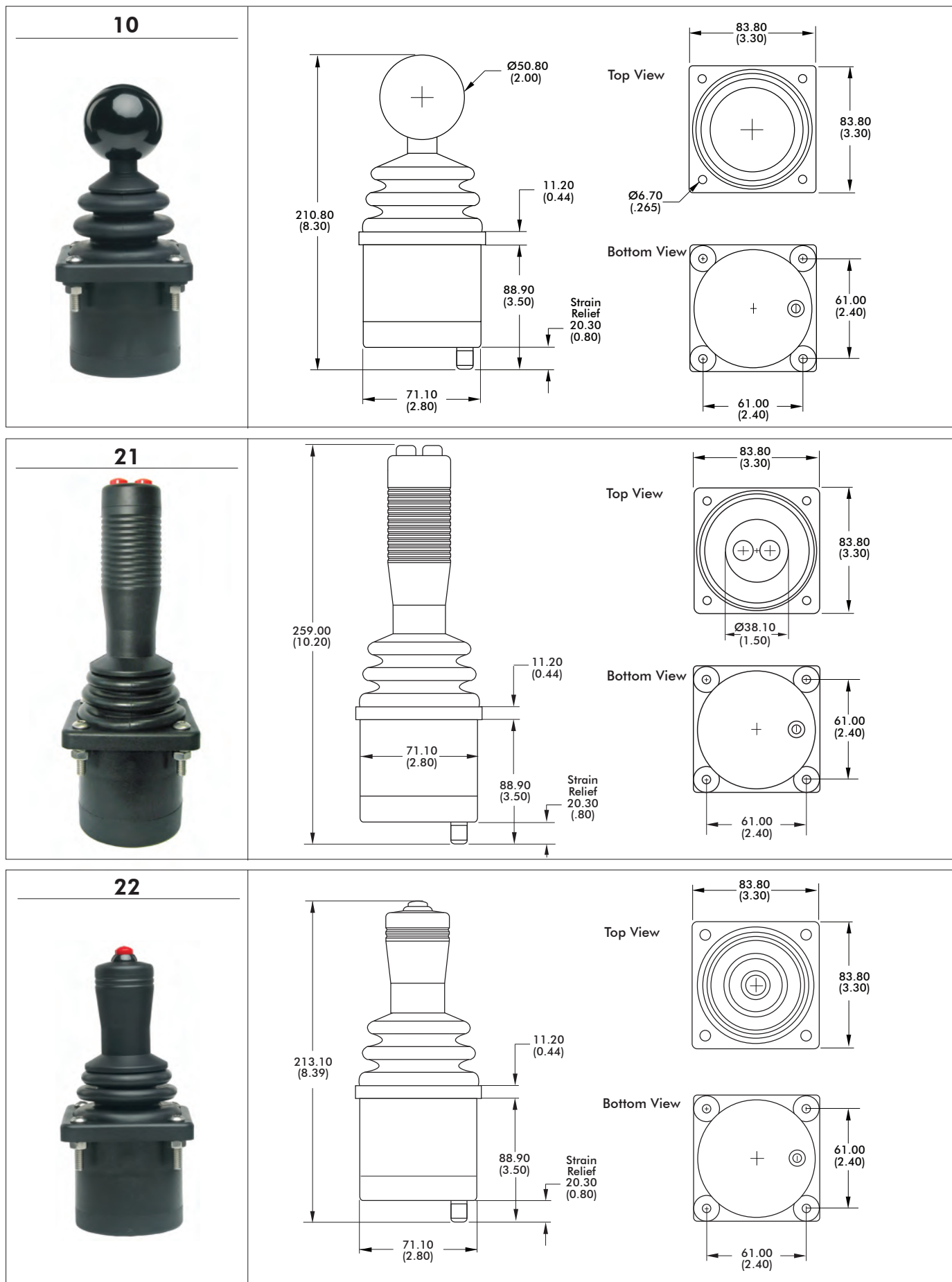

# HG series

## Hand grip Hall effect joysticks

### DIMENSIONAL DRAWINGS - continued

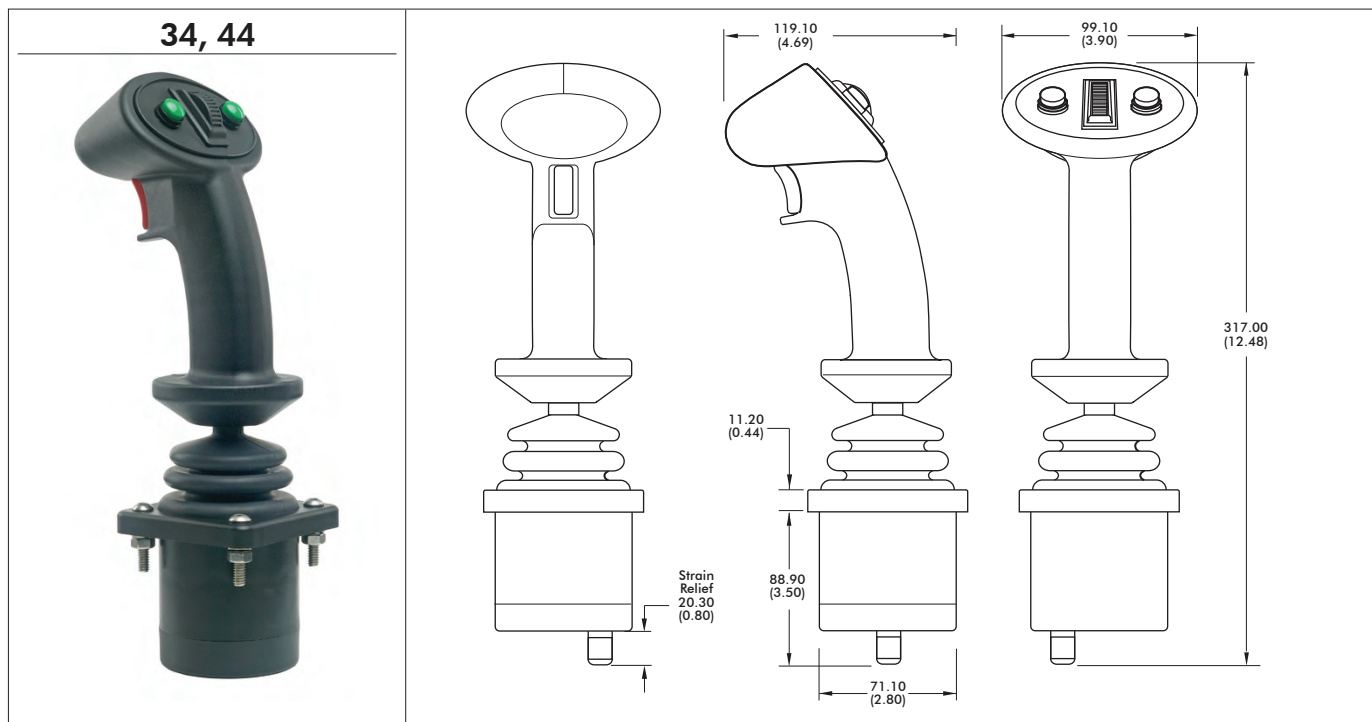
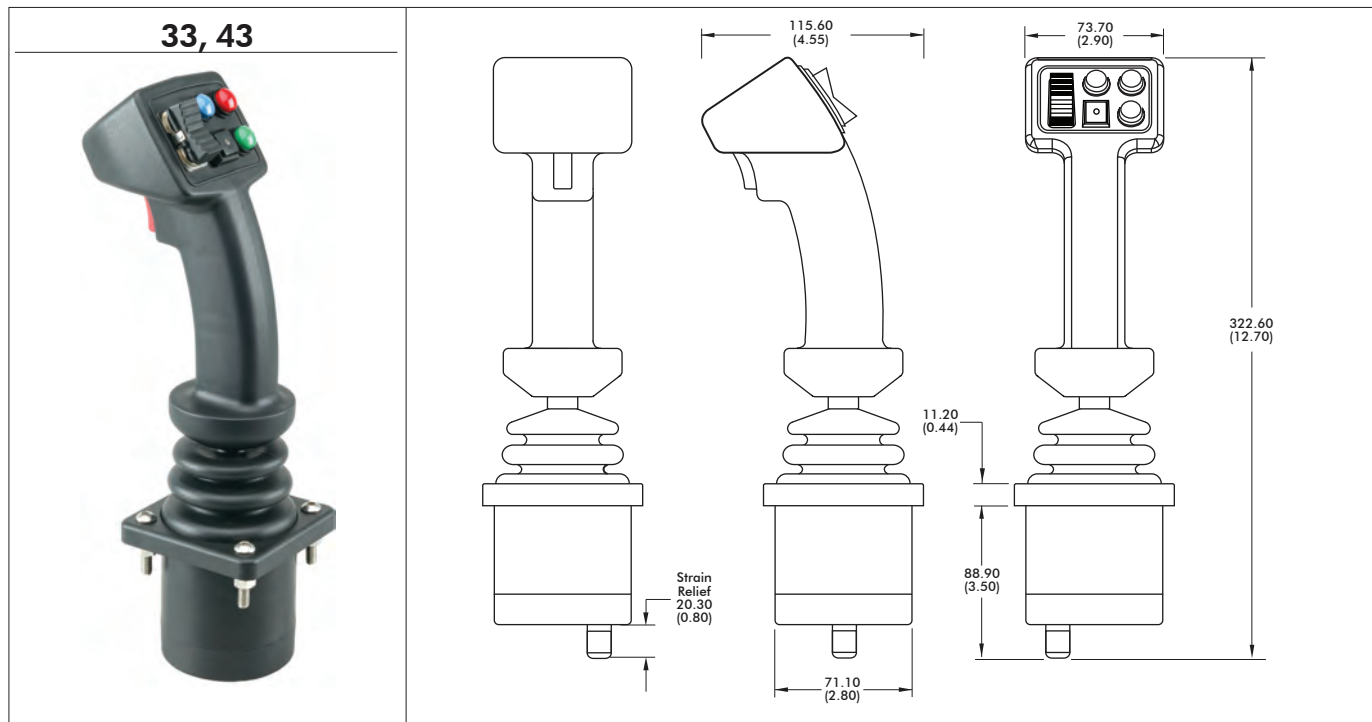

**NOTES**

1. Dimensions are in mm/(inch)
2. Actual strain relief position may vary.
3. For below panel lower profile housings, the strain relief [20.30/(0.80)] can be replaced with a rubber grommet [1.27/(0.05)], and the standard housing cap [18.54/(0.73)] can be replaced with a short cap [11.94/(0.47)]. These options are available only for joysticks without additional boards, except USB.

4. Axes orientation:

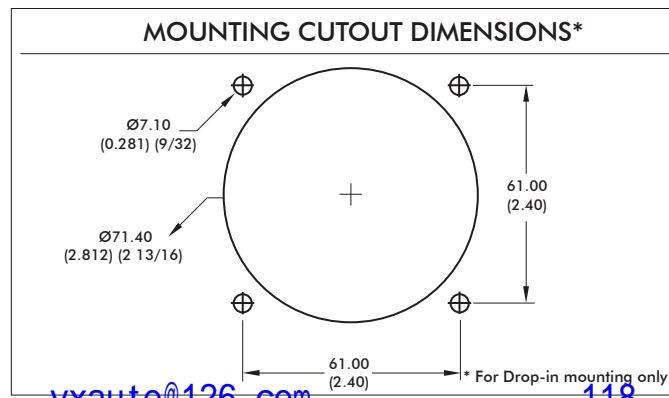
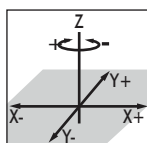



# HG series

## Hand grip Hall effect joysticks

### CONFIGURATION OPTIONS

#### LINEAR OUTPUT OPTIONS

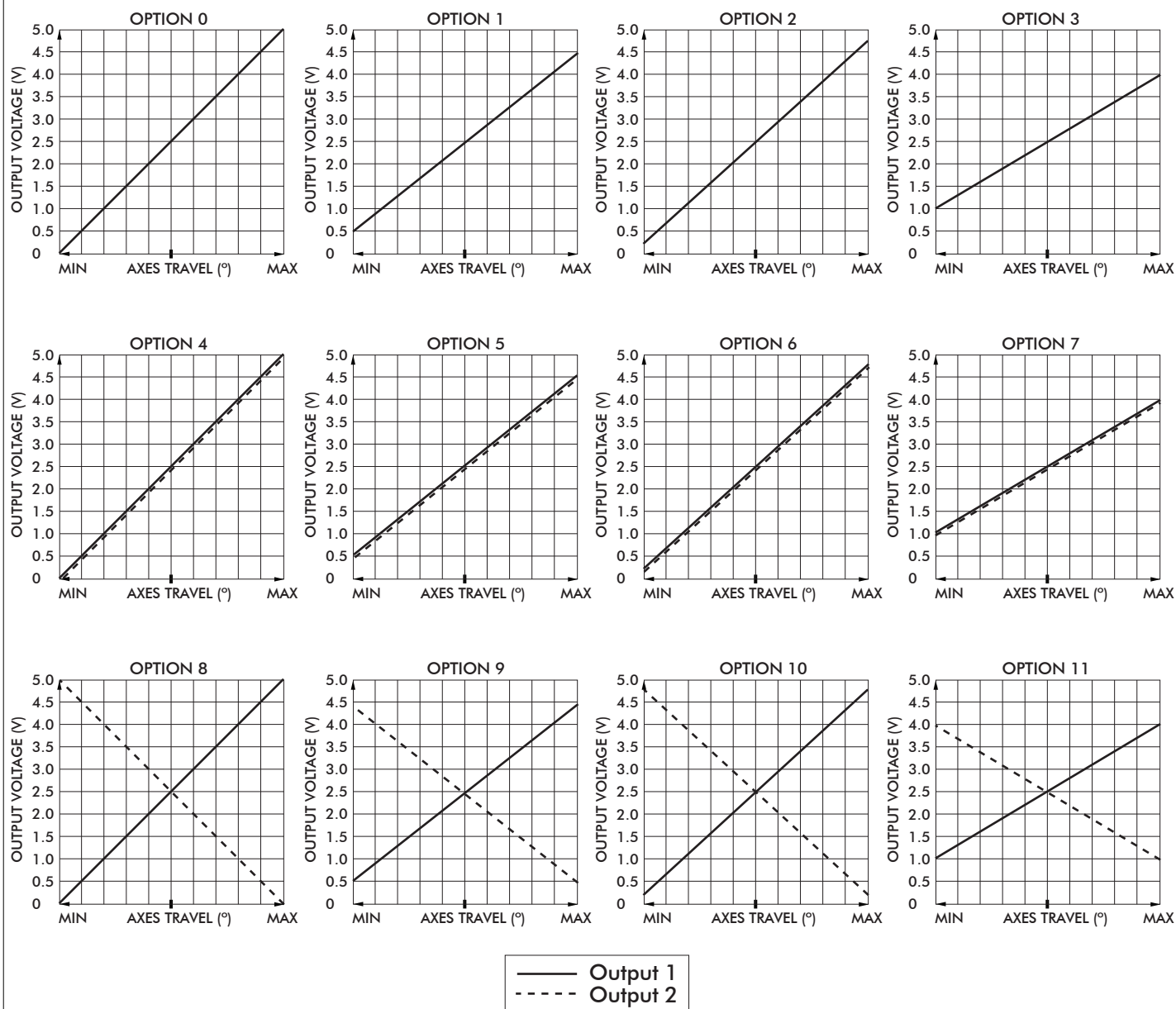



# HG series

## Hand grip Hall effect joysticks

### CONFIGURATION OPTIONS - continued

#### ADDITIONAL OUTPUT OPTIONS

### CANbus J1939

CH Products HG CANbus joysticks conform to the SAE J1939 serial bus specification used for communications between electronic control units and vehicle components. The HG CANbus option provides I/O extension for up to 51 digital and eight analog inputs.

#### FEATURES

- CANbus J1939
- Extended I/O extension for up to 51 digital and eight analog inputs.
- Accommodates a 6-40VDC power supply
- Operating temperature: -40°C to +85°C (-40°F to +185°F)
- Storage temperature: -60°C to +150°C (-60°F to +302°F)

#### ELECTRICAL SPECIFICATIONS

Supply Power:	-	6 – 40 VDC
Supply Current:	-	15mA min, +5mA per LED, +6mA per axis

#### WIRING SPECIFICATION

Red Wire	-	Supply Power
Black Wire	-	Ground
Green Wire	-	CAN high data
White Wire	-	CAN low data
Blue Wire	-	Identifier Select
Orange Wire	-	Identifier Select

#### CONNECTOR OPTIONS:

- Cable assembly with Deutsch DT04 style plugs
- External i/o harnessing per customer specification

#### CANbus CONFIGURATION CHART

- Contact factory for assistance

BAUD RATE (Check one)		250K	500K	1000K		BLUE WIRE	ORANGE WIRE
11 BIT IDENTIFIER (CAN2.0A) (Hex)	#1 TX	1	0			G	G
	RX						
	#2 TX						G
	RX						
	#3 TX					G	
	RX						
	#4 TX						
	RX						
29 BIT IDENTIFIER (CAN2.0B) (Hex)	#1 TX	3	2	1	0	G	G
	RX						
	#2 TX						G
	RX						
	#3 TX					G	
	RX						
	#4 TX						
	RX						
8 BYTE TX DATA FRAME (Binary)		7	6	5	4	3	2
8 BYTE RX DATA FRAME (Binary)							1
AXIS DATA TYPE (Check one)		SIGNED CHAR (+/-127)	UNSIGNED CHAR (0-255)	UNSIGNED INT (0-1023)	UNSIGNED INT (0-4095)		0
							IDENTIFIER SELECT WIRES
							(SUPPLIED IN PIGTAIL)
							G-TIED TO 0V (BLACK WIRE)

# HG series

Hand grip Hall effect joysticks

CONFIGURATION OPTIONS - continued

## ADDITIONAL OUTPUT OPTIONS

### PLUG-AND-PLAY SOLUTIONS:

#### USB

Featuring USB 1.1 HID compliant interface, CH Products' USB joysticks are recognized as standard HID "game controller" devices. Adhering to the HID specification, CH Products' USB joysticks are plug-and-play with most versions of Windows and Linux. Joystick button and axes assignments are dependent upon the controlled application.

#### FEATURES

- USB 1.1 HID compliant "game controller" device
- Easy to install and operate
- Functions determined by controlled application
- Standard male type "A" connector

#### SUPPLIED WIRING

USB: USB Male Type A Connector with over-molded cable  
(Optional ruggedized military connectors are available.)



USB Male Type A Connector

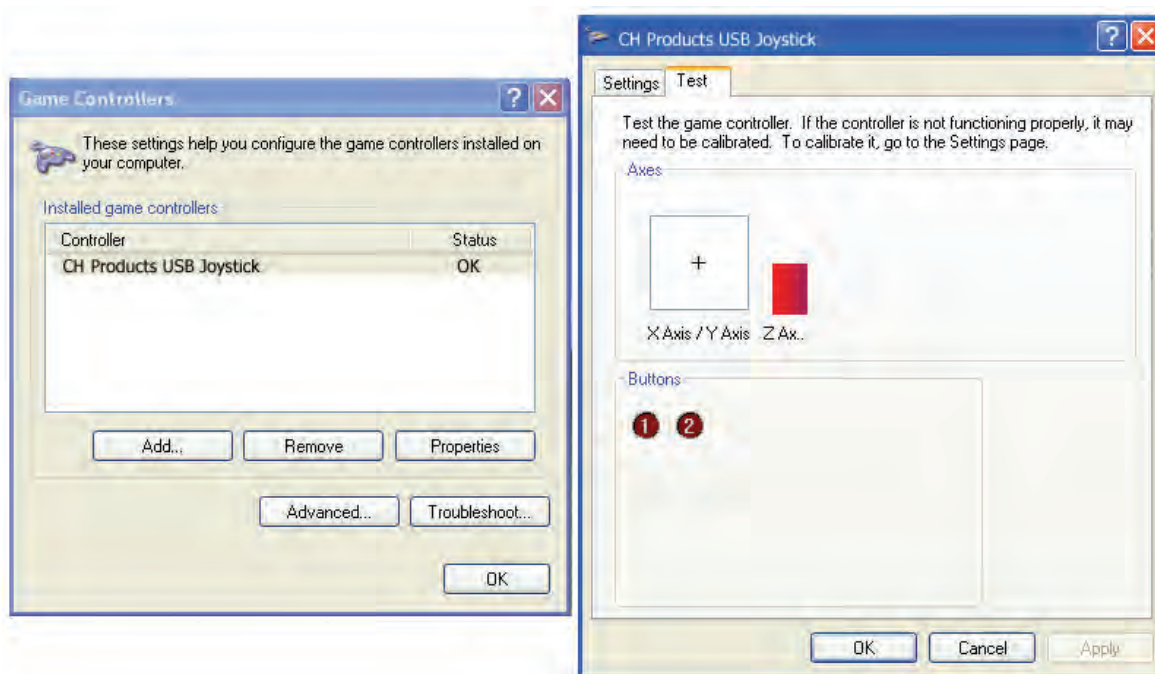

# HG series

## Hand grip Hall effect joysticks

### CONFIGURATION OPTIONS - continued

#### ADDITIONAL OUTPUT OPTIONS

### JOYBALL (CURSOR EMULATION)

The Joyball option converts multi-axis joystick output into a mouse, trackball, or cursor control device. The joystick's internal microprocessor converts absolute axis position into a cursor velocity, which is translated as a relative trackball or mouse position. Supported protocols include Sun Microsystems (mouse systems 5vdc serial) and USB.

#### APPLICATIONS

The Joyball option is ideal for vehicle applications subjected to dirt and high vibration which make operating a traditional cursor control device difficult. The Joyball option is widely used in shipboard and military applications.

#### FEATURES

- HID compliant "pointing device"
- Plug-and-play with USB option
- Ideal for marine GPS and navigation
- Environmental sealing up to IP68

#### SUPPLIED WIRING

USB: USB Male Type A Connector with over-molded cable

SUN: SUN mini-DIN plug with overmolded cable and strain relief

#### I/O COMPLEMENT/ USER SPECIFIED PARAMETERS:

- USB 4 pushbuttons 2 or 3 axes (X,Y, and Z "scroll")
- SUN 2 pushbuttons and 2 axes (X, Y)

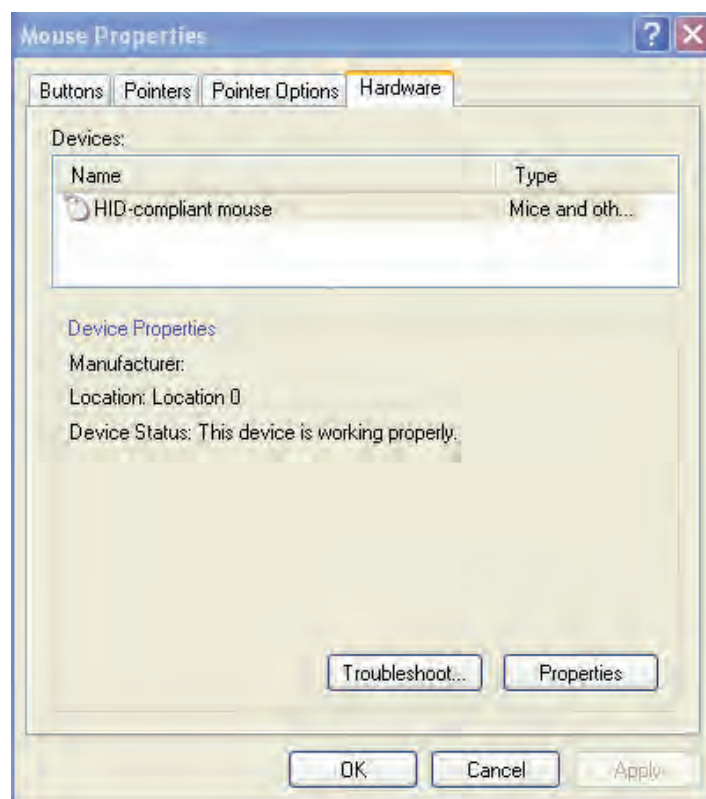

# HG series

## Hand grip Hall effect joysticks

### CONFIGURATION OPTIONS - continued

#### ADDITIONAL OUTPUT OPTIONS

#### DUAL DECODE

Dual Decode utilizes a microprocessor to monitor two linear opposite-ramp signals for each joystick axis and provides one proportional (0.5VDC – 4.5VDC) and one logical output accordingly. The dual inversed signals are continuously monitored and a logical signal of 0VDC is provided for over-range (>4.5VDC), under-range (<0.5VDC) and signal tracking (sum of both signals equals 4.5V +/-10%) error. A logical signal of 5.0VDC is provided for a properly functioning joystick deflected from center.

#### APPLICATIONS

Dual Decode provides a center detect function as well as error tracking, making it ideal for high liability, safety critical applications.

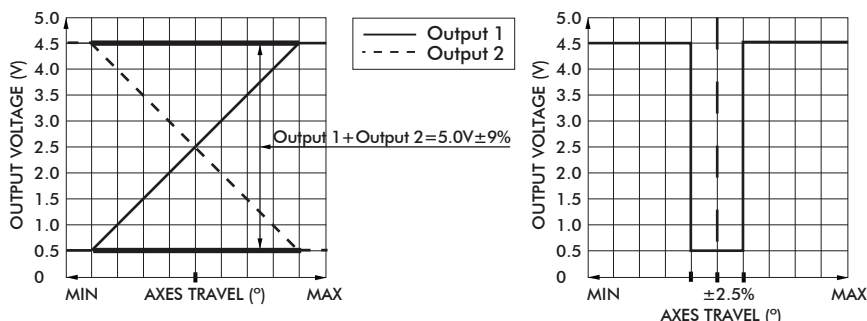

#### ELECTRICAL SPECIFICATIONS

Supply Power	-	4.5VDC to 5.5VDC
Supply Current	-	30mA + 10mA per axis

#### WIRING SPECIFICATION

Red wire	-	Customer power supply 4.5VDC-5.5VDC
Black wire	-	Ground
Blue wire	-	X axis output
Yellow wire	-	Y axis output
Green wire	-	Z axis output
Blue/White wire	-	X axis dual decode logic output
Yellow/Black wire	-	Y axis dual decode logic output
Green/Black wire	-	Z axis dual decode logic output
White wire	-	Pushbutton common wire
Orange, violet, gray, brown, pink, bl/wt/y/bk, gn/bk, gy/w wire	-	Pushbutton outputs

#### ANALOG DEADBAND

Analog Deadband utilizes an analog circuit to monitor proportional joystick outputs and enhance return to center accuracy over multiple axes. Specified for joysticks with normally ranged outputs of 0VDC – 5VDC at full axis travel, a constant output of 2.5VDC is provided for the joystick's position +/-2.5° from center.

#### APPLICATIONS

Analog Deadband effectively eliminates mechanical return-to-center error, making it ideally suited for safety critical applications susceptible to drift and motion control systems lacking center position trim.

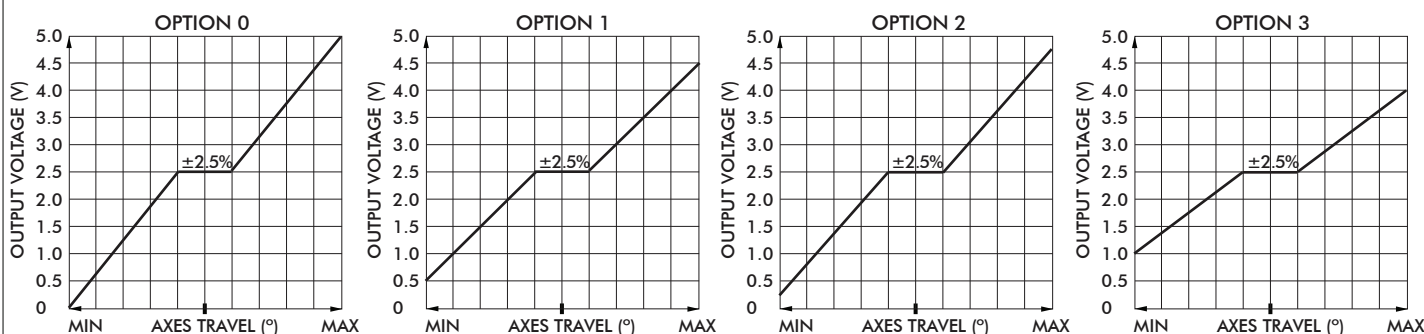

# HG series

## Hand grip Hall effect joysticks

### CONFIGURATION OPTIONS - continued

#### ADDITIONAL OUTPUT OPTIONS

##### ELECTRICAL SPECIFICATIONS

Supply Power	-	4.5VDC to 5.5VDC
Supply Current	-	10mA per axis

##### WIRING SPECIFICATION

Red wire	-	Customer power supply 4.5-5.5vdc
Black wire	-	Ground
Blue wire	-	X axis output
Yellow wire	-	Y axis output
Green wire	-	Z axis output
White wire	-	Pushbutton common wire
Orange,violet,gray,brown,pink,bl/wt/y/bk,gn/bk,gy/w wire	-	Pushbutton outputs

### CENTER DETECT

Center Detect utilizes a microprocessor to monitor joystick output and provides both logic and proportional signals for enhanced operator safety. Specified for a joystick normally ranged 0.5VDC to 4.5VDC, the microprocessor continuously monitors the proportional output and provides HI logic signal (5.0VDC) when moved off center and an LO logical signal (0VDC) for an over-range (>4.5VDC) or under-range (<0.5VDC).

#### APPLICATIONS

Center Detect is ideal for safety critical applications including master relay control "MCR" for a motion control system or as a brake release for an overhauling load.

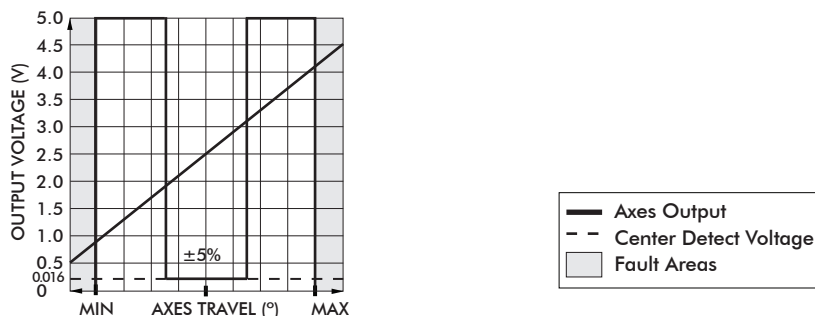

##### ELECTRICAL SPECIFICATIONS

Supply Power	-	4.5V to 5.5V
Supply Current	-	30mA + 10mA per axis

##### WIRING SPECIFICATIONS

Red Wire	-	Power supply 4.5 - 5.5VDC
Black Wire	-	Ground
Blue Wire	-	X axis output
Yellow Wire	-	Y axis output
Green Wire	-	Z axis output
Blue/White Wire	-	X axis center detect logic output
Yellow/Black Wire	-	Y axis center detect logic output
Green/Black Wire	-	Z axis center detect logic output
White Wire	-	Pushbutton common wire
Orange,violet,gray,brown,pink,bl/wt,y/bk,gn/bk,gy/w wire	-	Pushbutton outputs



# HG series

## Hand grip Hall effect joysticks

### CONFIGURATION OPTIONS - continued

#### ADDITIONAL OUTPUT OPTIONS

#### DISCRETE OUTPUT

Discrete Output is a microprocessor based option providing up to 6 hi voltage/hi current, on/off outputs as well as proportional outputs. Featuring a microcontroller, an a/d converter, and 4 to 8 optically isolated solid state switches, the Discrete Output provides an electronic "switch stick" function. Switch combinations and firing angles are programmed to the application's requirement.

#### APPLICATIONS

The Discrete Output option is designed for small motor, reversing starters or hydraulic solenoid actuations.

#### DC SPECIFICATIONS

Supply Voltage Operating	-	5.0- 40VDC input power
Supply Current	-	30mA + 10mA per hall sensor
Sourcing Outputs	-	70V AC/DC @ 1.6A max.
Sinking Outputs	-	70V AC/DC @ 3.6A max.
Discrete Output Max	-	60VDC/AC, 3.2A per discrete output

#### WIRING

Red Wire	-	Customer power supply 5 - 40VDC
Black Wire	-	Ground
Blue Wire	-	X axis output
Yellow Wire	-	Y axis output
Green Wire	-	Z axis output
Blue/White Wire	-	X axis discrete output
Yellow/Black Wire	-	Y axis discrete output
Green/Black Wire	-	Z axis discrete output
White Wire	-	Pushbutton common wire
Orange,violet,gray,brown,pink,bl/wt,y/bk,gn/bk,gy/w wire	-	Pushbutton outputs

#### I/O COMPLEMENT AND USER SPECIFIED PARAMETERS:

Up to 3 axes and 6 discrete sourcing or sinking outputs.

#### DISCRETE OUTPUT CONFIGURATION FORM:

Discrete Output	Sourcing	Sinking	AC	DC
Xfwd				
Xrev				
Yfwd				
Yrev				
Zfwd				
Zrev				

#### SAMPLE OF COMPLETED FORM:

(Please enter required choices for each applicable axis and return form to factory.)

Discrete Output	Sourcing	Sinking	AC	DC
Xfwd		X		X
Xrev		X		X
Yfwd	X			X
Yrev	X			X
Zfwd		X		X
Zrev		X		X

# HG series

## Hand grip Hall effect joysticks

### CONFIGURATION OPTIONS - continued

#### ADDITIONAL OUTPUT OPTIONS

#### VOLTAGE REGULATOR

The Voltage Regulator is a multi-wired analog option to mate a Hall effect joystick to a variety of industrial control voltages. The Voltage Regulator may be used when the supply or output voltage is greater than 5V or when bipolar output is required.

User Specified Supply Voltage:

- 5 VDC
- 10 VDC
- 12 VDC
- 24 – 30 VDC
- Custom supply options available.

User Specified Output Voltage:

- 0-5 VDC
- 0-10 VDC
- +/-5 VDC
- +/-10 VDC
- Custom outputs available.

#### ELECTRICAL SPECIFICATIONS

Supply Power	-	5VDC to 30VDC
Supply Current	-	90mA max

#### WIRING SPECIFICATION

Red wire	-	Supply power 5-30VDC
Black wire	-	Ground
Blue wire	-	X axis output
Yellow wire	-	Y axis output
Green wire	-	Z axis output
White wire	-	Pushbutton common wire
Orange,violet,gray,brown,pink,bl/wt/y/bk,gn/bk,gy/w wire	-	Pushbutton outputs





# FG series

FIXED GRIP™ hand controllers



The FG Series of FIXED GRIP hand controllers provide rugged, yet ergonomic operation for the most demanding applications. Custom configured to order, the FG Series may be equipped, for example, with a miniature thumb operated two axes joystick, index trigger guard, and USB interface. The FG Series of FIXED GRIP controllers are ideal for off-road vehicle, marine, and military applications subject to high vibration.

## KEY FEATURES

- USB outputs available**
- Rugged hand operation**
- Sealed up to IP67**
- Custom configured**
- Available with optional programming utility**



# FG series

## FIXED GRIP™ hand controllers

### OPTION SELECTION

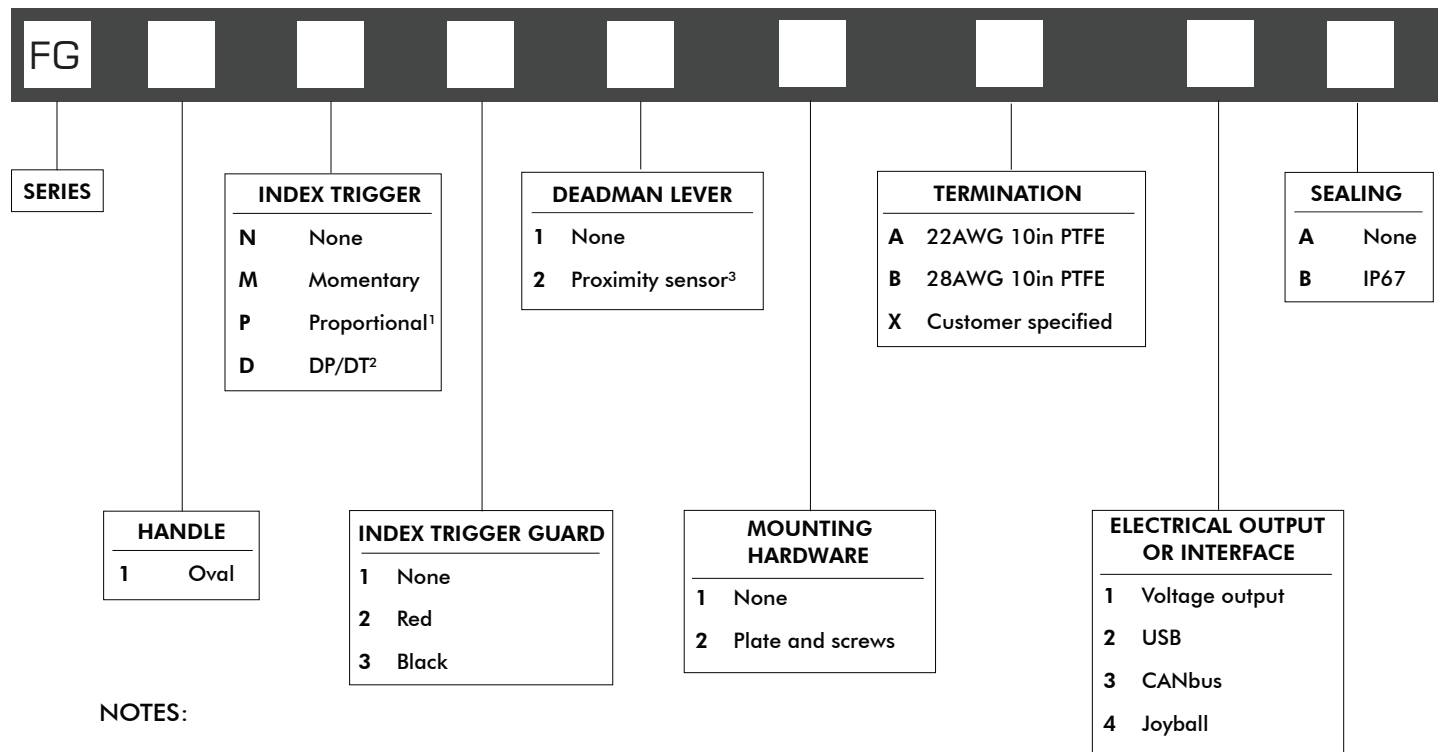

**NOTES:**

- 1 0.5V to 4.5V output
- 2 Double pole/double throw
- 3 Not available with trigger



Up to IP67 available.



Mounting accessories. Screws: 1/4-20 x 1.25in stainless steel screws, lock washers, and hex nuts

### SPECIFICATIONS

ENVIRONMENTAL	
Operating Temperature	-25°C to 85°C (-13°F to 185°F)
Storage Temperature	-40°C to 85°C (-40°F to 185°F)
Sealing	IP67
EMC Immunity Level (V/M)	IEC 61000-4-8:2009
EMC Emissions Level	IEC 61000-4-3:2006
ESD	IEC 61000-4-2:2008

STANDARD SWITCH CHARACTERISTICS/RATINGS	
Electrical Resistive Load:	5A
Electrical Inductive Load:	3A
Dielectric Withstandind Voltage:	1050Vrms
Low Level:	10mA @ 30mV
Electrical Life:	25,000 cycles 5A @ 28VDC resistive snap-action
Mechanical Life:	1,000,000 cycles
Environmental Seal:	IP67
Action:	Momentary, snap-action
Operating Force:	7.5N+/-2.0N (1.69lbf+/-0.11lb)
Total Travel:	0.080 inch max
Over Travel:	0.010 inch min

**NOTE:**

All values are nominal



# FG series

FIXED GRIP™ hand controllers

## FACEPLATE EXAMPLES

### OVAL



1



2



3



4

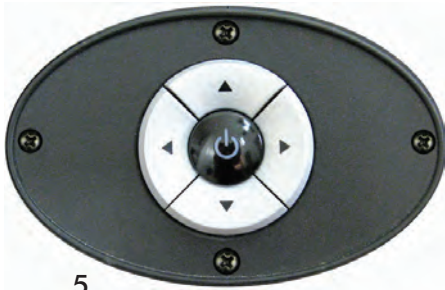

5



6



7



8



9

### HANDLE / INDEX TRIGGER

#### INDEX TRIGGER WITH TRIGGER GUARD

#### INDEX TRIGGER

#### NO INDEX TRIGGER





# FG series

FIXED GRIP™ hand controllers

DIMENSIONAL DRAWINGS

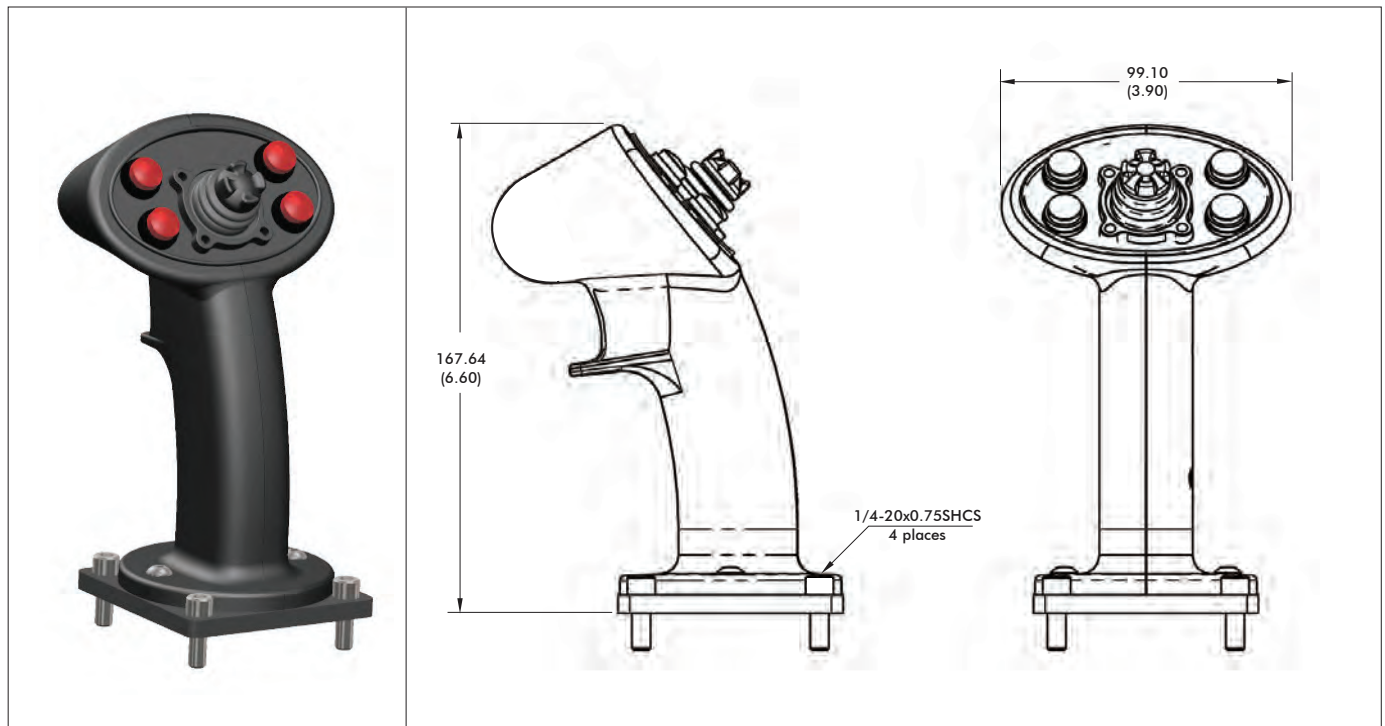

## NOTES

1. Dimensions are in mm/(inch)

### 2. Faceplate

The FG FIXED GRIP hand controller features a modular faceplate that can be customized for specific applications. Ambidextrous for most configurations, the faceplate may be populated with a variety of thumb actuated switches including momentary pushbuttons, latching pushbuttons, two or three way toggle switches, 4 or 5 way trims, and miniature proportional joysticks. Every FG faceplate is custom configured to order. Please consult factory for options.

### 3. Index Trigger

The FG Series handle may be equipped with or without in index trigger switch. Index trigger configure options include a single pole normally open momentary switch, a double pole double throw tactile switch, or a proportional Hall effect device.

#### Index Trigger Options

- N: None
- M: Momentary, single pole normally open
- P: Hall effect, 0.5V to 4.5V proportional output
- D: Double pole, double throw

### 4. Deadman Lever

The Proximity Sensor is a person present "deadman" safety switch that works by means of capacitive sensing. Fitted inside the handle and sealed from the environment, the Proximity Sensor eliminates the need for a mechanical paddle lever.

#### Deadman Lever Option

- 1: None
- 2: Proximity Sensor

# FG series

## FIXED GRIP™ hand controllers

### CONFIGURATION OPTIONS - continued

#### OUTPUT OPTIONS

#### PLUG-AND-PLAY SOLUTIONS:

#### USB

Featuring USB 1.1 HID compliant interface, CH Products' USB FIXED GRIP controllers are recognized as standard HID "game controller" devices. Adhering to the HID specification, CH Products' USB FIXED GRIP controllers are plug-and-play with most versions of Windows and Linux. FIXED GRIP controller's buttons and axes assignments are dependent upon the controlled application.

#### FEATURES

- USB 1.1 HID compliant "game controller" device
- Easy to install and operate
- Functions determined by controlled application
- Standard male type "A" connector

#### SUPPLIED WIRING

USB: USB Male Type A Connector with over-molded cable (Optional ruggedized military connectors are available.)



USB Male Type A Connector

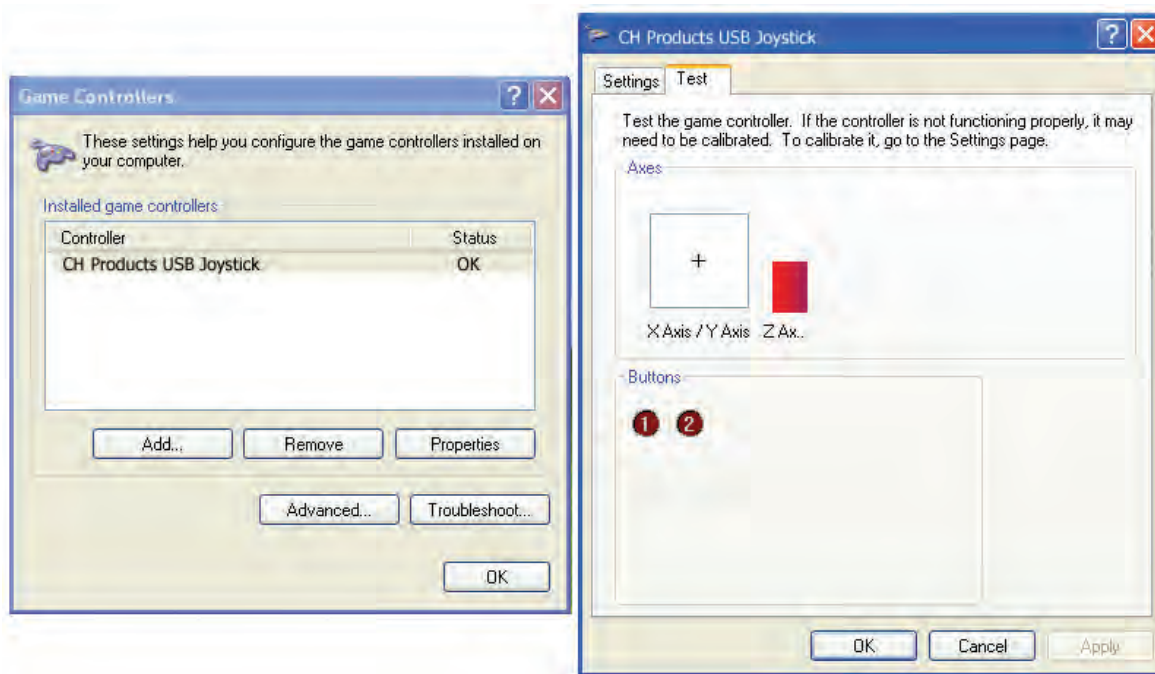

# FG series

## FIXED GRIP™ hand controllers

### CONFIGURATION OPTIONS - continued

#### ADDITIONAL OUTPUT OPTIONS

### JOYBALL (CURSOR EMULATION)

The Joyball option converts multi-axis joystick output into a mouse, trackball, or cursor control device. The FIXED GRIP controller's internal microprocessor converts absolute axis position into a cursor velocity, which is translated as a relative trackball or mouse position. Supported protocols include Sun Microsystems (mouse systems 5vdc serial) and USB.

#### APPLICATIONS

The Joyball option is ideal for vehicle applications subjected to dirt and high vibration which make operating a traditional cursor control device difficult. The Joyball option is widely used in shipboard and military applications.

#### FEATURES

- HID compliant "pointing device"
- Plug-and-play with USB option
- Ideal for marine GPS and navigation
- Environmental sealing up to IP67

#### SUPPLIED WIRING

USB: USB Male Type A Connector with over-molded cable

SUN: SUN mini-DIN plug with overmolded cable and strain relief

#### I/O COMPLEMENT/ USER SPECIFIED PARAMETERS:

- USB 4 pushbuttons 2 or 3 axes (X,Y, and Z "scroll")
- SUN 2 pushbuttons and 2 axes (X, Y)

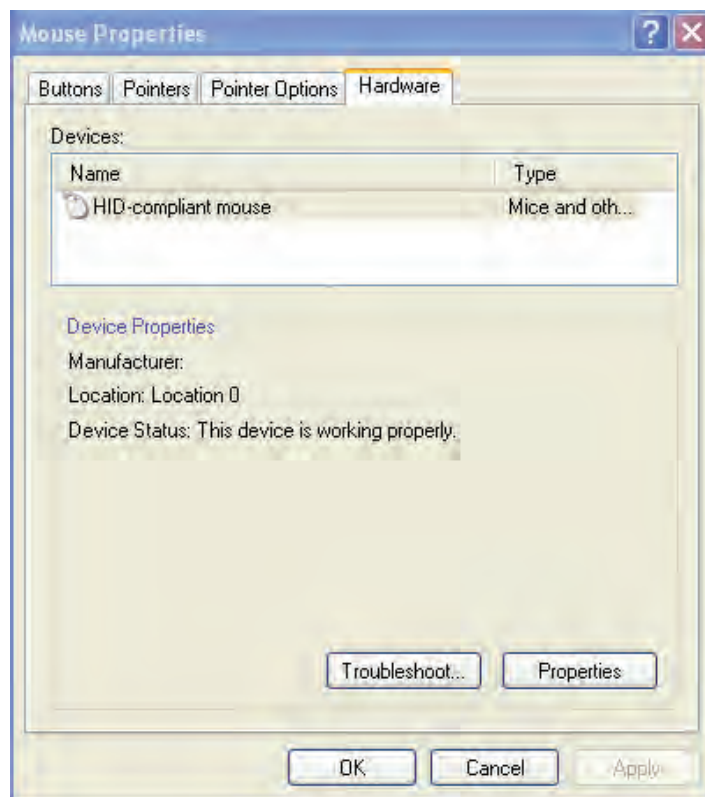

# FG series

## FIXED GRIP™ hand controllers

### CONFIGURATION OPTIONS

#### ADDITIONAL OUTPUT OPTIONS

### CANbus J1939

CH Products FG CANbus joysticks conform to the SAE J1939 serial bus specification used for communications between electronic control units and vehicle components.

#### FEATURES

- CANbus J1939
- Extended I/O extension for up to 2 digital and 3 analog inputs.
- Accommodates a 6-40VDC power supply

#### ELECTRICAL SPECIFICATIONS

Supply Power:	-	6 – 40 VDC
Supply Current:	-	15mA min, +5mA per LED, +6mA per axis

#### WIRING SPECIFICATION

Red Wire	-	Supply Power
Black Wire	-	Ground
Green Wire	-	CAN high data
White Wire	-	CAN low data
Blue Wire	-	Identifier Select
Orange Wire	-	Identifier Select

#### CONNECTOR OPTIONS:

- Cable assembly with Deutsch DT04 style plugs
- External I/O harnessing per customer specification

#### CANbus CONFIGURATION CHART

- Contact factory for assistance

BAUD RATE (Check one)		250K		500K		1000K		BLUE WIRE	ORANGE WIRE
11 BIT IDENTIFIER (CAN2.0A) (Hex)	#1	TX	1	0				G	G
		RX							
	#2	TX							G
		RX							
29 BIT IDENTIFIER (CAN2.0B) (Hex)	#3	TX						G	
		RX							
	#4	TX							
		RX							
8 BYTE TX DATA FRAME (Binary)	#1	TX	3	2	1	0		G	G
		RX							
8 BYTE RX DATA FRAME (Binary)	#2	TX							G
		RX							
AXIS DATA TYPE (Check one)									
		SIGNED CHAR (+/-127)	UNSIGNED CHAR (0-255)	UNSIGNED INT (0-1023)	UNSIGNED INT (0-4095)				IDENTIFIER SELECT WIRES (SUPPLIED IN PIGTAIL) G-TIED TO 0V (BLACK WIRE)





# TH series

Single-axis throttle joysticks



The TH Single Axis Throttle is a heavy duty friction clutch joystick delivering proportional control. Designed for prolonged use and durable enough to withstand rough operation, commonly used applications include material handling and mobile equipment. The TH Single Axis Throttle utilizes non-contacting Hall effect technology. Configuration options include mechanical detents and electronic microswitches.

## KEY FEATURES

- Rugged, hand operation
- Hall effect sensing
- Single axis friction clutch operation
- Optional mechanical detents with microswitches
- CANbus J1939 and USB options
- Redundant output available
- Sealed up to IP68





# TH series

## Single-axis throttles joysticks

### OPTION SELECTION

TH														
<b>SERIES</b>	<b>FRONT BUTTONS</b>		<b>SIDE BUTTONS*</b>			<b>MECHANICAL DETENTS</b>		<b>OUTPUT OPTIONS</b>						
	0	None	0	None	0	None	0	None	0	0V to 5V (Rail to Rail)				
	1	One	U	One - Upper Position	1	-35°	1	0.5V to 4.5V	1	0.5V to 4.5V				
			L	One - Lower Position	2	0°	2	0.25V to 4.75V	2	0.25V to 4.75V				
			T	Two	3	+35°	3	0V to 5V - Sensor 1 0V to 5V - Sensor 2	3	0V to 5V - Sensor 1 0V to 5V - Sensor 2				
			D	Deadman	4	-35° and 0°	4	0.5V to 4.5V - Sensor 1 0.5V to 4.5V - Sensor 2	4	0.5V to 4.5V - Sensor 1 0.5V to 4.5V - Sensor 2				
			M	Multifunction (includes Index Trigger)	5	-35° and +35°	5	0.25V to 4.75V - Sensor 1 0.25V to 4.75V - Sensor 2	5	0.25V to 4.75V - Sensor 1 0.25V to 4.75V - Sensor 2				
			P	Palm Grip (includes 1 Front Button)	6	0° and +35°	6	0V to 5V - Sensor 1 5V to 0V - Sensor 2	6	0V to 5V - Sensor 1 5V to 0V - Sensor 2				
				* - All that apply.	7	-35°, 0° and +35°	7	0.5V to 4.5V - Sensor 1 4.5V to 0.5V - Sensor 2	7	0.5V to 4.5V - Sensor 1 4.5V to 0.5V - Sensor 2				
								8	0.25V to 4.75V - Sensor 1 4.75V to 0.25V - Sensor 2	8	0.25V to 4.75V - Sensor 1 4.75V to 0.25V - Sensor 2			
								0-U	USB	0-U	USB			
								0-D	Discrete	0-D	Discrete			
								2-C	CANbus	2-C	CANbus			
<b>HANDLE</b>			<b>TOP BUTTONS</b>			<b>MICROSWITCHES</b>			<b>MOUNTING OPTIONS</b>		<b>ADDITIONAL OPTIONS</b>			
0	Ball Tip		0	None		0	None		R	Rear mount		V	Voltage Regulator	
1	Stock Grip <sup>1, 2</sup>		1	One		1	-35°		D	Drop-in		D	Dual Decode <sub>9</sub>	
2	Short Stock Grip <sup>1</sup>		2	Two		2	0°					AD	Analog Deadband	
3	Multifunction Square <sup>3</sup>		3	Multifunction*		3	+35°					DC	Center Detect	
4	Multifunction Oval <sup>3</sup>			* - Multifunction handle will be specified in an extension		4	-35° and 0°					P	Proximity Sensor	
5	Palm Grip					5	-35° and +35°					E	Environmental Sealing	
X	No Handle <sup>8</sup>					6	0° and +35°							
Z	Custom Handle <sup>8</sup>					7	-35°, 0° and +35°							

**NOTES:**

1. Refer to next page for information on standard configurations for throttles with Stock Grip and Short Stock Grip handles.
2. Stock Grip handles can have either a Deadman or a Proximity Switch.
3. Refer to next page for information on standard configurations for joysticks with Multifunction handles.
4. Multifunction handles can have either an Index Trigger or a Proximity Switch.
5. Multifunction handle orders should be accompanied by drawing of button/component placement.
6. Multifunction handle requires Drop-in mounting.
7. Option X (no handle) and Option Z (custom handle) may require discussion with Technical Support.
8. Dual Decode cannot be used with CANbus, USB, or Voltage Regulator.



Up to IP68 available.



Mounting accessories. Standard hardware includes: 1 gasket, 4 screws (10-32x3/4 Phillips Flat Head), 4 washers (#10 Split Lock), 4 nuts (10-332 Hex). The gasket and the mounting hardware are shipped off the throttle, in a separate bag.

# TH series

Single-axis throttle joysticks

STANDARD CONFIGURATIONS

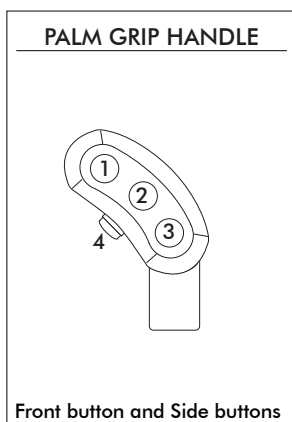
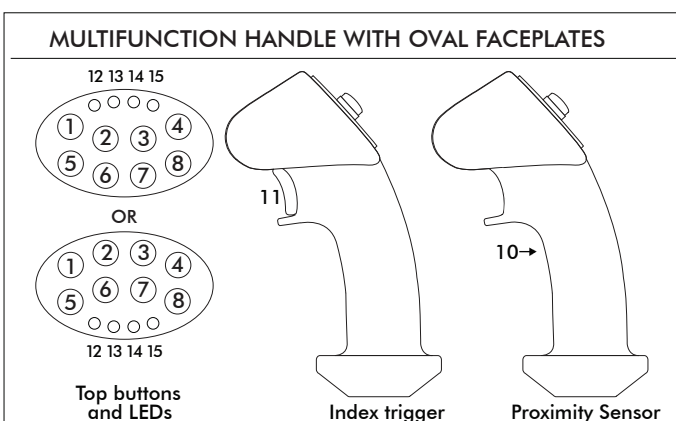
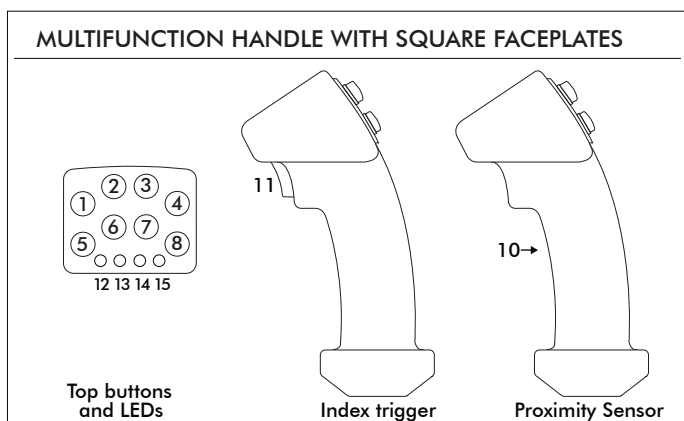
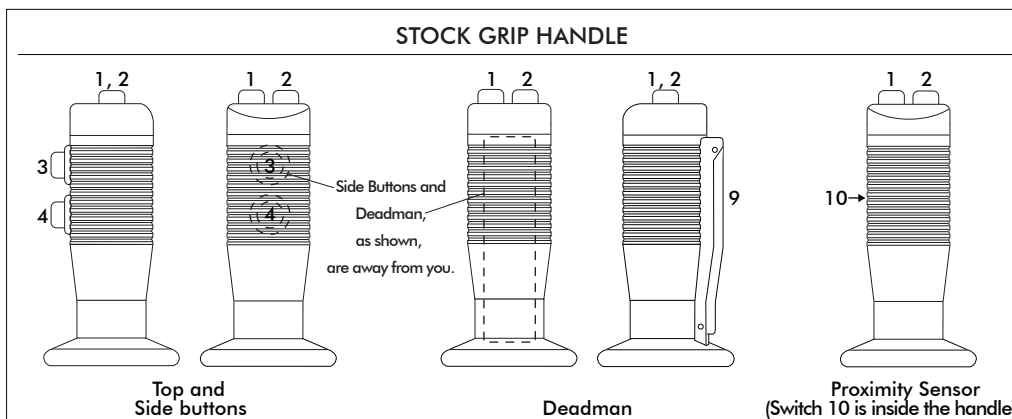

DEFAULT WIRE COLOR CODE*			
COLOR	FUNCTION	AWG	
RED	Vcc or Vdd	28	
BLACK	Ground		
BLUE	X Axis		
YELLOW	Y Axis		
GREEN	Z Axis		
WHITE	Switch Common (optional)	22	
ORANGE	Switch 1 (optional)		
VIOLET	Switch 2 (optional)		
GRAY	Switch 3 (optional)		
BROWN	Switch 4 (optional)		
PINK	Switch 5 (optional)		
BLUE/WHITE	Switch 6 (optional)		
YELLOW/BLACK	Switch 7 (optional)		
GREEN/BLACK	Switch 8 (optional)		
PURPLE/WHITE	Deadman - Switch 9 (optional)		
YELLOW/WHITE	Proximity Sensor - Switch 10 (optional)		
RED/WHITE	Index trigger - Switch 11 (optional)		
LIGHT GREEN	LED - 12 (optional)		
LIGHT ORANGE	LED - 13 (optional)		
GRAY/WHITE	LED - 14 (optional)		
BLACK/WHITE	LED - 15 (optional)		



**NOTES:**

\* - Starting from the stain relief, the cable is 406mm (16in) long, 6.40mm (0.25in) stripped with plug, covered with an expandable cable sleeve.

- The maximum possible configuration for the Short Stock Grip handle is up to 2 Top Buttons. It is not possible with Deadman, Index Trigger, Proximity Switch, or Side Buttons.
- The maximum possible configuration for the Stock Grip handle is up to 2 Top Buttons and 2 Side Buttons. A handle with a Deadman or a Proximity Sensor can have 2 Top Buttons, but no Side Buttons.
- A Multifunction handle can have a maximum of 8 Top Buttons and 4 LEDs on the faceplate, and an Index Trigger or a Proximity Sensor.
- For non-standard configurations contact Technical Support. We can customize the faceplate according to your exact needs. For faceplate examples, see next page.
- If unspecified, the pushbuttons will have snap action momentary switches with red button caps.
- Switches will always be wired according to the position number on the handle and the Default Wire Color Code.

# TH series

Single-axis throttle joysticks

FACEPLATE EXAMPLES

## OVAL



1



2



3



4

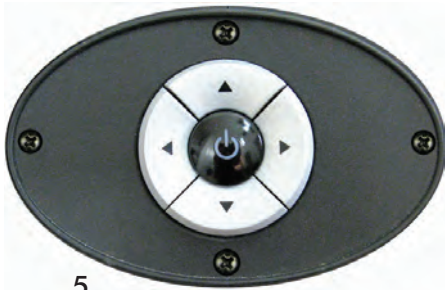

5



6



7



8



9

## SQUARE



10



11



12



13



14



15



16



17

# TH series

## Single-axis throttle joysticks

### SPECIFICATIONS

#### MECHANICAL

Break Out Force	-	6.6N (1.50lbf)
Operating Force	-	7.7N (1.70lbf)
Mechanical Angle of Movement	-	70°
Expected Life	-	10 million cycles
Mass/weight	-	Varies
Material	-	Glass reinforced nylon
Lever Action (Centering)	-	Friction

#### ENVIRONMENTAL

Operating Temperature	-	-25°C to 70°C (-13°F to 158°F)
Storage Temperature	-	-40°C to 70°C (-40°F to 158°F)
Sealing (IP)	-	IP65 to IP68*
EMC Immunity Level (V/M)	-	IEC 61000-4-8:2009
EMC Emissions Level	-	IEC 61000-4-3:2006
ESD	-	IEC 61000-4-2:2008

#### ELECTRICAL

Sensor	-	Hall effect
Resolution	-	Infinite
Supply Voltage Operating	-	5.00VDC
Reverse Polarity Max	-	-14.5VDC
Overvoltage Max	-	18VDC
Output Impedance	-	6Ω
Current Consumption Max	-	10mA
Error Signal	-	2%

#### ELECTRICAL MICROSWITCH

Electrical rating	-	0.1 A at 30 VDC (resistive load)
Operating speed	-	1mm to 250 mm/s
Operating frequency	-	Mechanical: 240 operations/min max. Electrical: 30 operations/min max.
Insulation resistance	-	100 MΩ min. (at 500 VDC)
Contact resistance	-	100 mΩ max.
Dielectric strength	-	600 VAC, 50/60 Hz for 1 min between terminals of the same polarity 1,000 VAC, 50/60 Hz for 1 min between current-carrying metal parts and ground, and between each terminal and non-current-carrying metal parts
Vibration resistance	-	Malfunction: 10 to 55 Hz, 1.5-mm double amplitude
Shock resistance	-	Destruction: 1,000 m/s <sup>2</sup> (approx. 100G) max. Malfunction: 200 m/s <sup>2</sup> (approx. 20G) max.
Durability	-	Mechanical: 1,000,000 operations min.(60 operations/min) Electrical: 100,000 operations min.(30 operations/min)
Sealing	-	IP67 (excluding solder terminals)
Operating temperature	-	-40°C to +85°C

#### STANDARD SWITCH CHARACTERISTICS/RATINGS

Electrical Resistive Load:	-	5A
Electrical Inductive Load:	-	3A
DWV:	-	1050Vrms
Low Level:	-	10mA @ 30mV
Electrical Life:	-	25,000 cycles 5A @ 28VDC resistive snap-action
Mechanical Life:	-	1million cycles
Environmental Seal:	-	IP67
Action:	-	Momentary, snap-action
Operating Force:	-	1.7 lbs +/- 0.5 lb
Total Travel:	-	0.080 inches max
Over Travel:	-	0.010 inches min

#### CANbus OUTPUT VERSION

Supply Voltage Range (Vdc)	-	6V to 40V
CANbus version	-	J1939

#### NOTES:

- All values are nominal
- Exact specifications may be subject to configuration.  
Contact Technical Support for the performance of your specific configuration.
- \* Excludes some handle options.



# TH series

Single-axis throttle joysticks

## DIMENSIONAL DRAWINGS

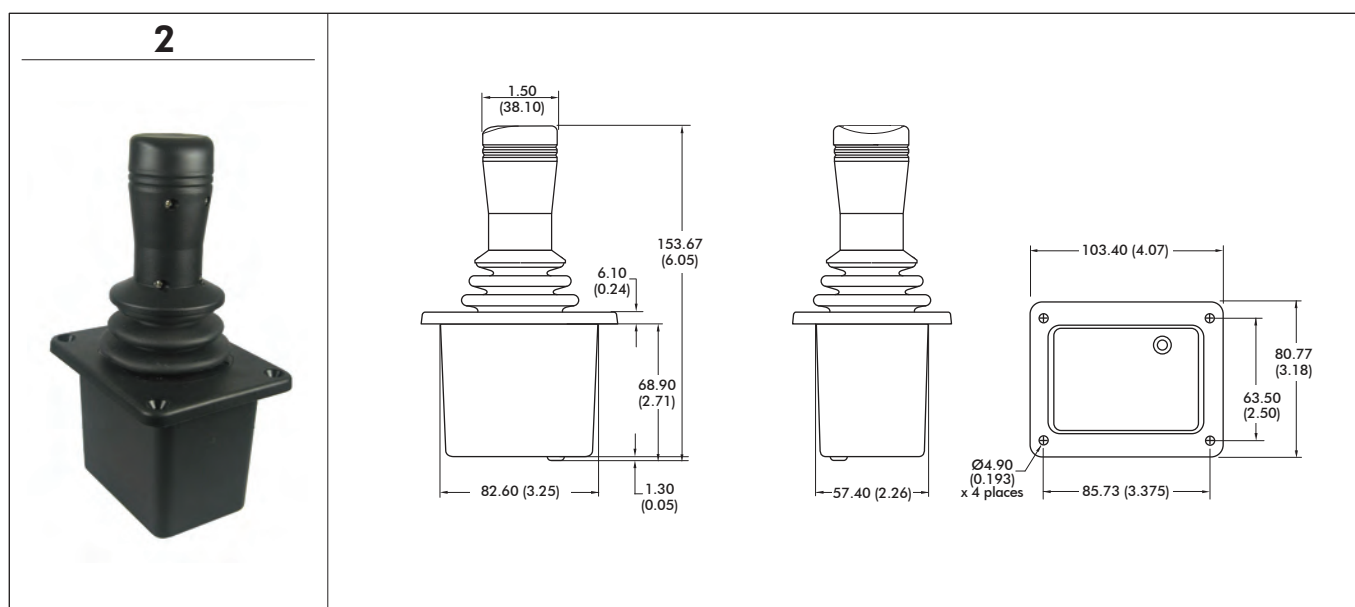
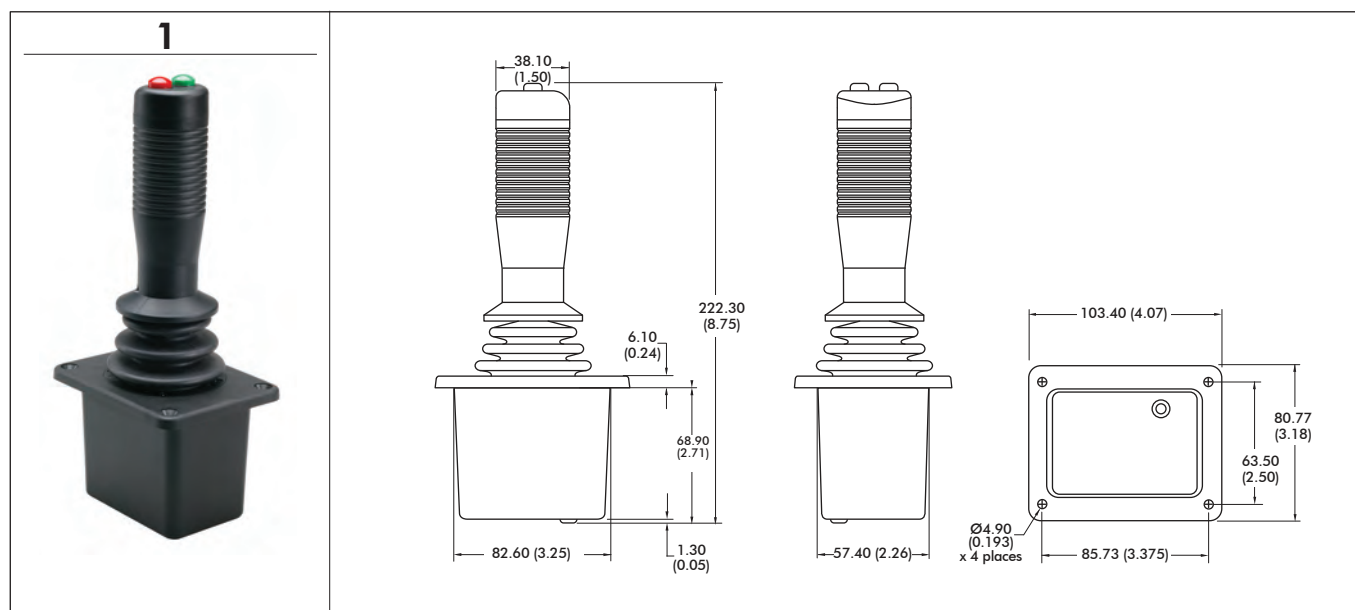
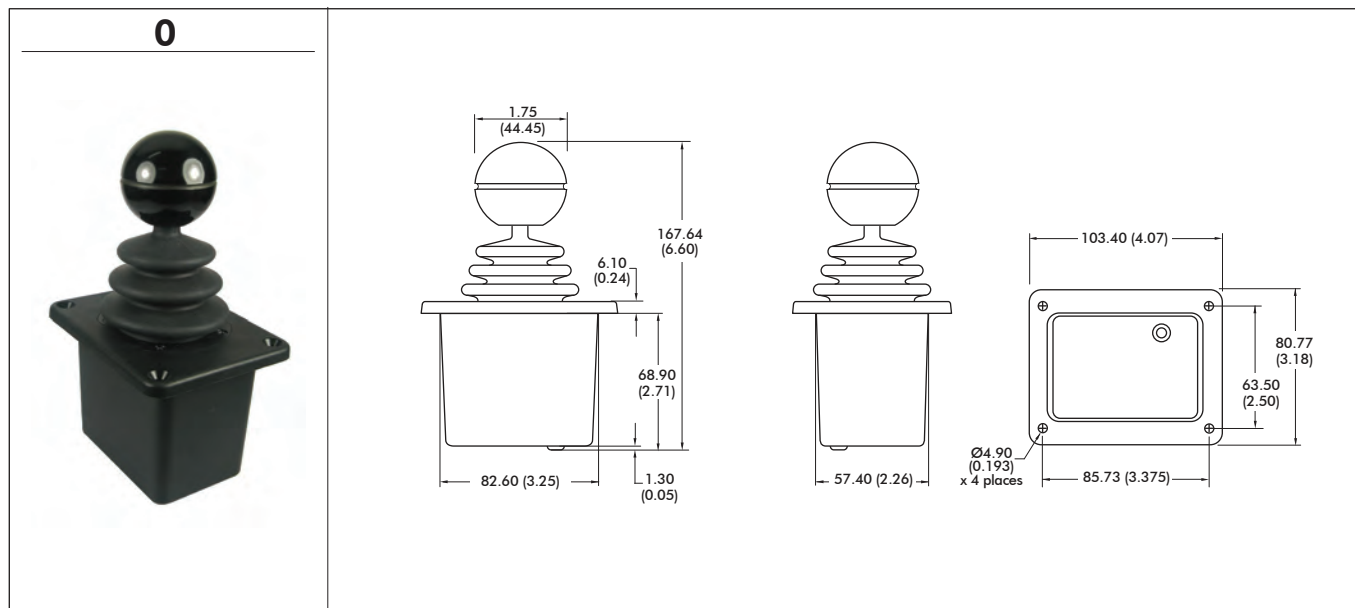



# TH series

## Single-axis throttle joysticks

### DIMENSIONAL DRAWINGS - continued

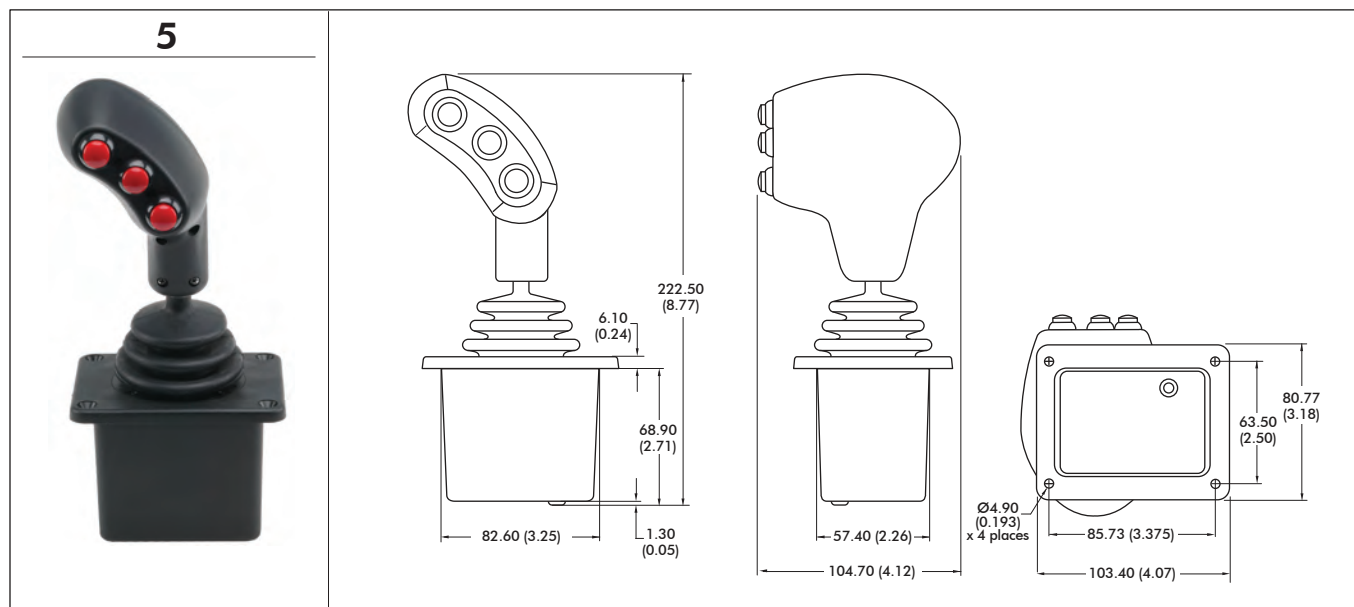
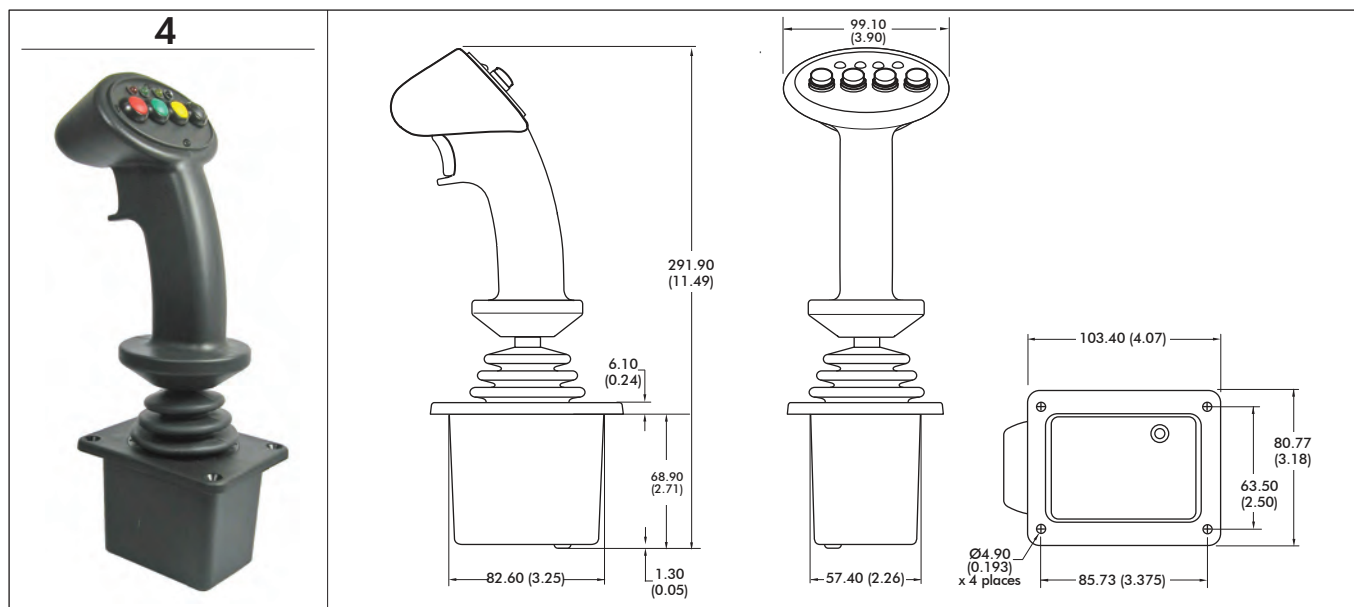
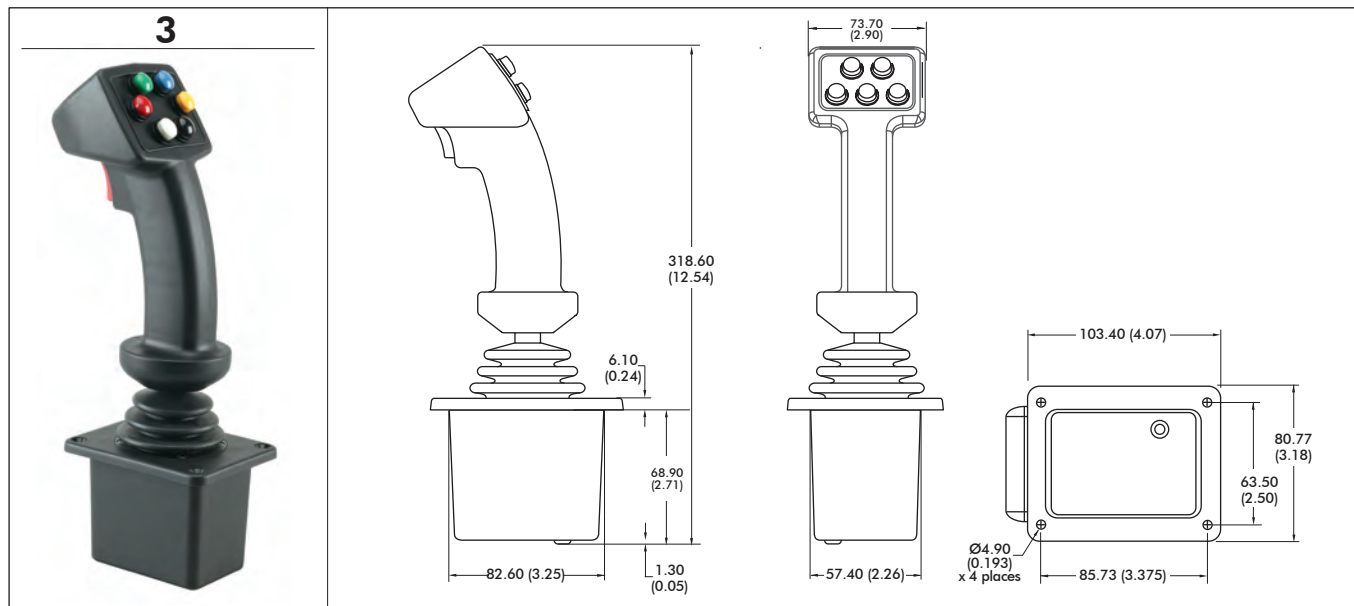

# TH series

## Single-axis throttle joysticks

### DIMENSIONAL DRAWINGS - continued

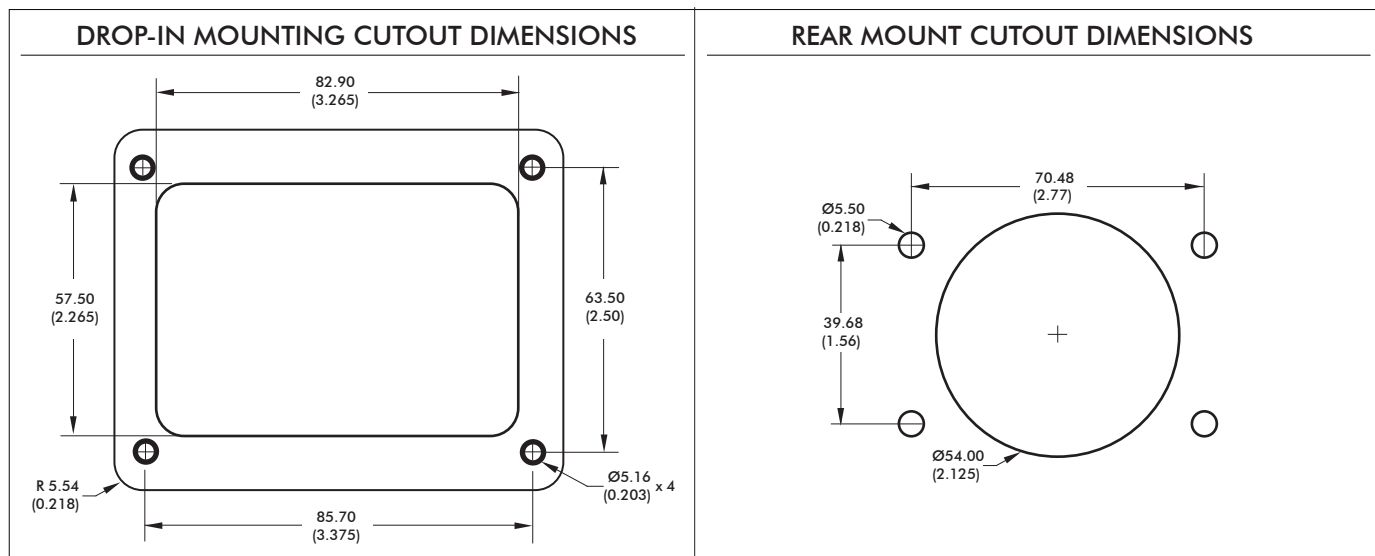
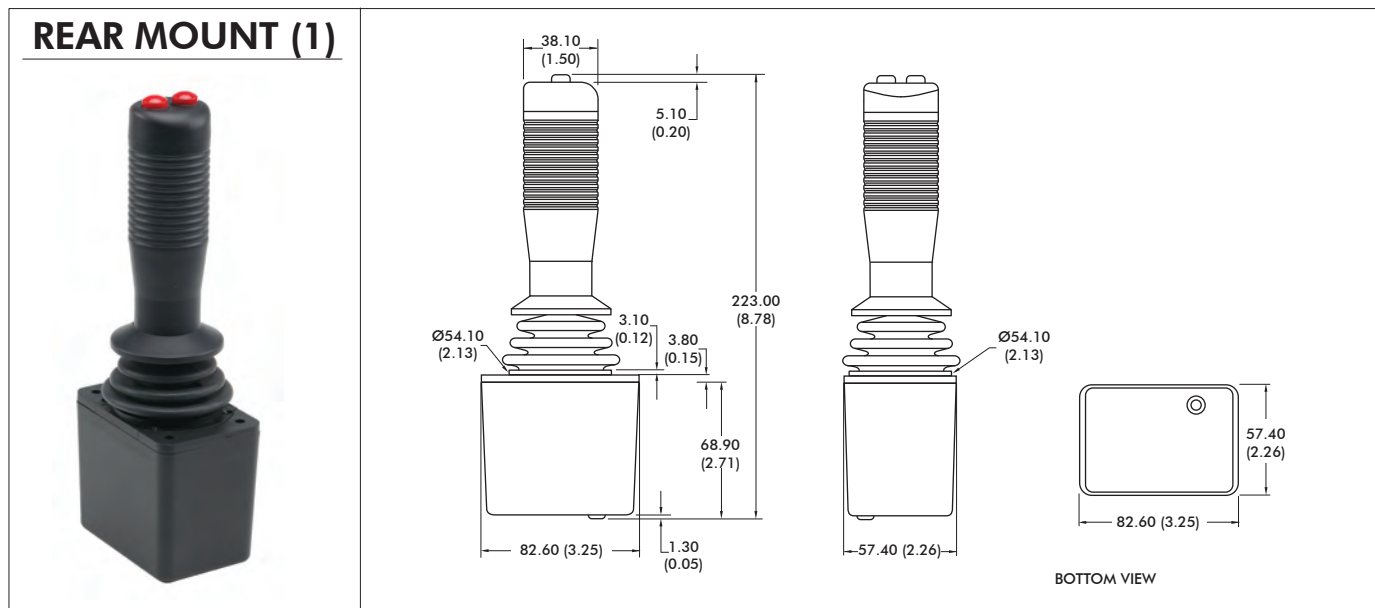

**NOTE:**

1. Dimensions are in mm/(inch)

# TH series

## Single-axis throttle joysticks

### CONFIGURATION OPTIONS

#### LINEAR OUTPUT OPTIONS

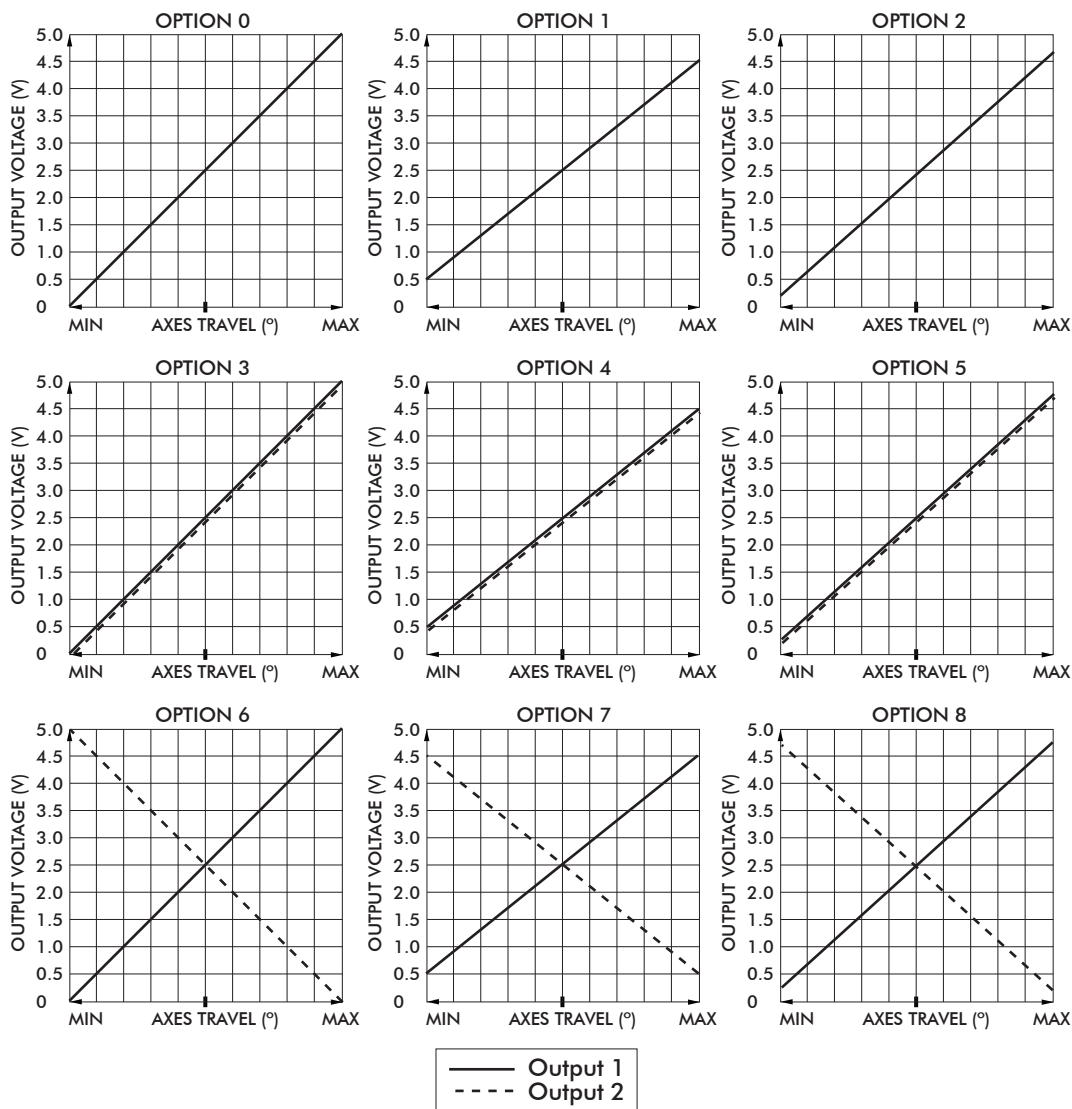

# TH series

## Single-axis throttle joysticks

### CONFIGURATION OPTIONS - continued

#### ADDITIONAL OUTPUT OPTIONS

### CANbus J1939

CH Products TH CANbus Throttles conform to the SAE J1939 serial bus specification used for communications between electronic control units and vehicle components.

#### FEATURES

- CANbus J1939
- Up to 16 digital and 3 analog inputs
- Accommodates a 6-40VDC power supply

#### ELECTRICAL SPECIFICATIONS

Supply Power:	-	6 – 40 VDC
Supply Current:	-	15mA min, +5mA per LED, +6mA per axis

#### WIRING SPECIFICATION

Red Wire	-	Supply Power
Black Wire	-	Ground
Green Wire	-	CAN high data
White Wire	-	CAN low data
Blue Wire	-	Identifier Select
Orange Wire	-	Identifier Select

#### CONNECTOR OPTIONS:

- Cable assembly with Deutsch DT04 style plugs
- External I/O harnessing per customer specification

#### CANbus CONFIGURATION CHART

- Contact factory for assistance

BAUD RATE <small>(Check one)</small>		250K	500K	1000K		BLUE WIRE	ORANGE WIRE
11 BIT IDENTIFIER <small>(CAN2.0A) (Hex)</small>	#1 TX	1	0			G	G
	RX						
	#2 TX						G
	RX						
	#3 TX					G	
	RX						
	#4 TX						
	RX						
29 BIT IDENTIFIER <small>(CAN2.0B) (Hex)</small>	#1 TX	3	2	1	0	G	G
	RX						
	#2 TX						G
	RX						
	#3 TX					G	
	RX						
	#4 TX						
	RX						
8 BYTE TX DATA FRAME <small>(Binary)</small>		7	6	5	4	3	2
8 BYTE RX DATA FRAME <small>(Binary)</small>							
AXIS DATA TYPE <small>(Check one)</small>		SIGNED CHAR <small>(+/-127)</small>	UNSIGNED CHAR <small>(0-255)</small>	UNSIGNED INT <small>(0-1023)</small>	UNSIGNED INT <small>(0-4095)</small>	G=TIED TO 0V <small>(BLACK WIRE)</small>	

# TH series

## Single-axis throttle joysticks

CONFIGURATION OPTIONS - continued

### ADDITIONAL OUTPUT OPTIONS

#### PLUG-AND-PLAY SOLUTIONS: USB

Featuring USB 1.1 HID compliant interface, CH Products' USB throttles are recognized as standard HID "game controller" devices. Adhering to the HID specification, CH Products' USB throttles are plug-and-play with most versions of Windows and Linux. Joystick button and axes assignments are dependent upon the controlled application.

#### FEATURES

- USB 1.1 HID compliant "game controller" device
- Easy to install and operate
- Functions determined by controlled application.
- Standard male type "A" connector

#### SUPPLIED WIRING

USB: USB Male Type A Connector with over-molded cable  
(Optional ruggedized military connectors are available.)



USB Male Type A Connector

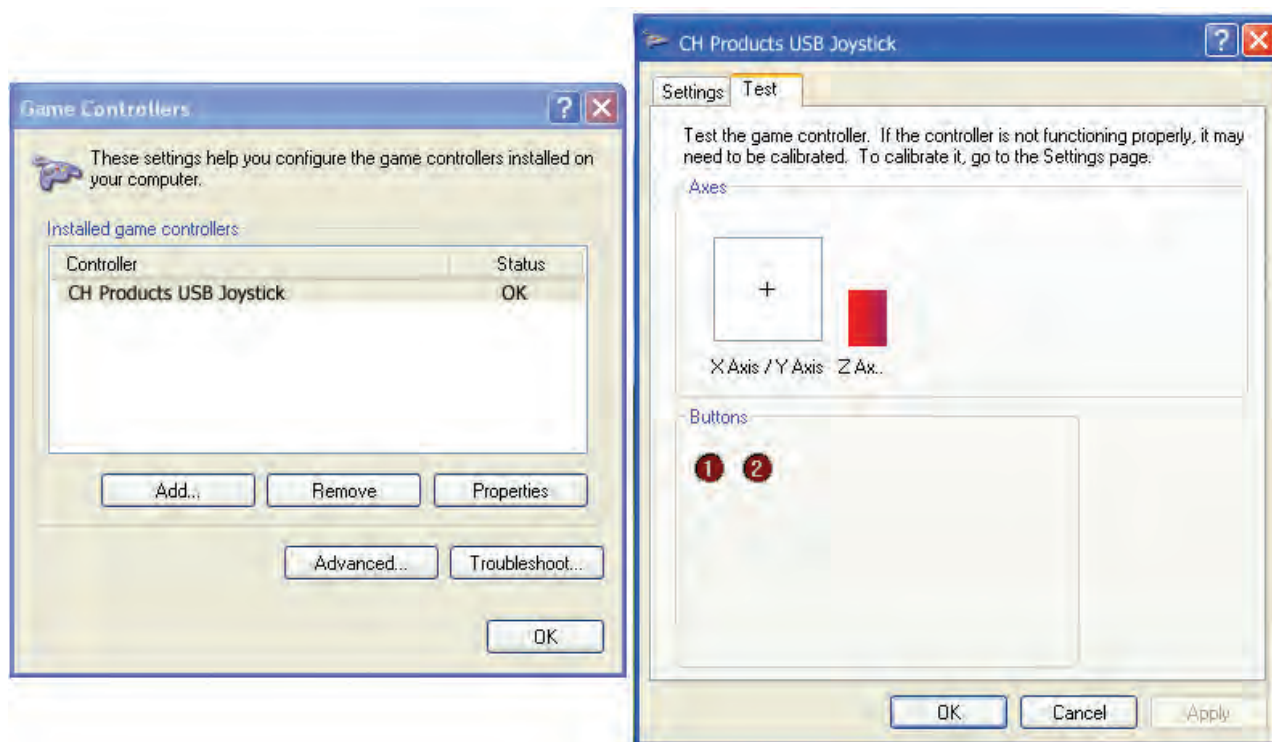



# TH series

## Single-axis throttle joysticks

### CONFIGURATION OPTIONS - continued

#### ADDITIONAL OUTPUT OPTIONS

#### VOLTAGE REGULATOR

The Voltage Regulator is a multi-wired analog option to mate a Hall effect throttle to a variety of industrial control voltages. The Voltage Regulator may be used when the supply or output voltage is greater than 5V or when bipolar output is required.

User Specified Supply Voltage:

- 5 VDC
- 10 VDC
- 12 VDC
- 24 – 30 VDC
- Custom supply options available.

User Specified Output Voltage:

- 0-5 VDC
- 0-10 VDC
- +/-5 VDC
- +/-10 VDC
- Custom outputs available.

#### ELECTRICAL SPECIFICATIONS

Supply Power	-	5VDC to 30VDC
Supply Current	-	90mA max

#### WIRING SPECIFICATION

Red wire	-	Supply power 5-30VDC
Black wire	-	Ground
Blue wire	-	X axis output
White wire	-	Pushbutton common wire
Orange,violet,gray,brown,pink,bl/wt/y/bk,gn/bk,gy/w wire	-	Pushbutton outputs

#### ANALOG DEADBAND

Analog Deadband utilizes an analog circuit to monitor proportional joystick outputs and enhance return to center accuracy over multiple axes. Specified for joysticks with normally ranged outputs of 0VDC – 5VDC at full axis travel, a constant output of 2.5VDC is provided for the joystick's position +/-2.5° from center.

#### APPLICATIONS

Analog Deadband effectively eliminates mechanical return-to-center error, making it ideally suited for safety critical applications susceptible to drift and motion control systems lacking center position trim.

#### ELECTRICAL SPECIFICATIONS

Supply Power	-	4.5VDC to 5.5VDC
Supply Current	-	10mA per axis

#### WIRING SPECIFICATION

Red wire	-	Customer power supply 4.5VDC-5.5VDC
Black wire	-	Customer power supply ground
Blue wire	-	X axis output
White wire	-	Pushbutton common wire
Orange,violet,gray,brown,pink,bl/wt/y/bk,gn/bk,gy/w wire	-	Pushbutton outputs

# TH series

## Single-axis throttle joysticks

### CONFIGURATION OPTIONS - continued

#### ADDITIONAL OUTPUT OPTIONS

##### ELECTRICAL SPECIFICATIONS

Supply Power	-	4.5VDC to 5.5VDC
Supply Current	-	10mA per axis

##### WIRING SPECIFICATION

Red wire	-	Customer power supply 4.5-5.5vdc
Black wire	-	Customer power supply ground
Blue wire	-	X axis output
White wire	-	Pushbutton common wire
Orange,violet,gray,brown,pink,bl/wt/y/bk,gn/bk,gy/w wire	-	Pushbutton outputs

## DISCRETE OUTPUT

Discrete Output is a microprocessor based option providing up to 6 hi voltage/hi current, on/off outputs as well as proportional outputs. Featuring a microcontroller, an a/d converter, and 4 to 8 optically isolated solid state switches, the Discrete Output provides an electronic "switch stick" function. Switch combinations and firing angles are programmed to the application's requirement.

### APPLICATIONS

The Discrete Output option is designed for small motor, reversing starters or hydraulic solenoid actuations.

##### DC SPECIFICATIONS

Supply Voltage Operating	-	5.0- 40VDC input power
Supply Current	-	30mA + 10mA per hall sensor
Sourcing Outputs	-	70V AC/DC @ 1.6A max.
Sinking Outputs	-	70V AC/DC @ 3.6A max.
Discrete Output Max	-	60VDC/AC, 3.2A per discrete output

##### WIRING

Red Wire	-	customer power supply 5 - 40VDC
Black Wire	-	customer power supply ground
Blue Wire	-	X axis output
Blue/White Wire	-	X axis discrete output
White Wire	-	pushbutton common wire
Orange,violet,gray,brown,pink,bl/wt/y/bk,gn/bk,gy/w wire	-	pushbutton outputs

### I/O COMPLEMENT AND USER SPECIFIED PARAMETERS:

Up to 3 axes and 6 discrete outputs sourcing or sinking discrete

#### DISCRETE OUTPUT CONFIGURATION FORM:

Discrete Output	Sourcing	Sinking	AC	DC
Xfwd				
Xrev				

#### SAMPLE OF COMPLETED FORM:

(Please enter required choices for each applicable axis and return form to factory.)

Discrete Output	Sourcing	Sinking	AC	DC
Xfwd		X		X
Xrev		X		X

# TH series

## Single-axis throttle joysticks

### CONFIGURATION OPTIONS - continued

#### ADDITIONAL OUTPUT OPTIONS

#### CENTER DETECT

Center Detect utilizes a microprocessor to monitor joystick output and provides both logic and proportional signals for enhanced operator safety. Specified for a joystick normally ranged 0.5VDC to 4.5VDC, the microprocessor continuously monitors the proportional output and provides HI logic signal (5.0VDC) when moved off center and an LO logical signal (0VDC) for an over-range (>4.5VDC) or under-range (<0.5VDC).

#### APPLICATIONS

Center Detect is ideal for safety critical applications including master relay control "MCR" for a motion control system or as a brake release for an overhauling load.

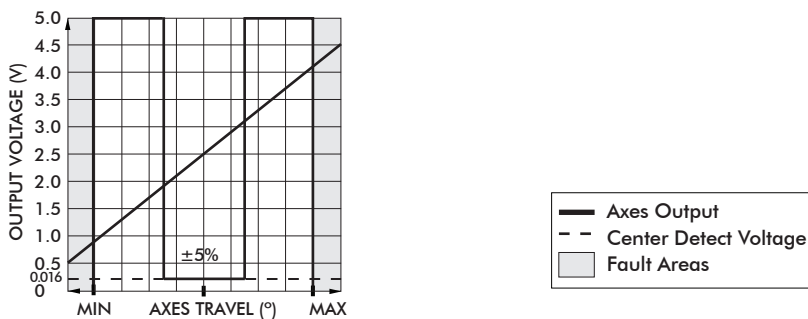

#### DC SPECIFICATIONS

Supply Power	-	4.5V to 5.5V
Supply Current	-	30mA + 10mA per axis

#### WIRING

Red Wire	-	power supply 4.5 - 5.5VDC
Black Wire	-	ground
Blue Wire	-	X axis output
Blue/White Wire	-	X axis center detect logic output
White Wire	-	pushbutton common wire
Orange,violet,gray,brown,pink,bl/wt,y/bk,gn/bk,gy/w wire	-	pushbutton outputs

# TH series

## Single-axis throttle joysticks

CONFIGURATION OPTIONS - continued

### ADDITIONAL OUTPUT OPTIONS

#### DUAL DECODE

Dual Decode utilizes a microprocessor to monitor two linear opposite-ramp signals for each joystick axis and provides one proportional (0.5VDC – 4.5VDC) and one logical output accordingly. The dual inversed signals are continuously monitored and a logical signal of 0VDC is provided for over-range (>4.5VDC), under-range (<0.5VDC) and signal tracking (sum of both signals equals 4.5V +/-10%) error. A logical signal of 5.0VDC is provided for a properly functioning joystick deflected from center.

#### APPLICATIONS

Dual Decode provides a center detect function as well as error tracking, making it ideal for high liability, safety critical applications.

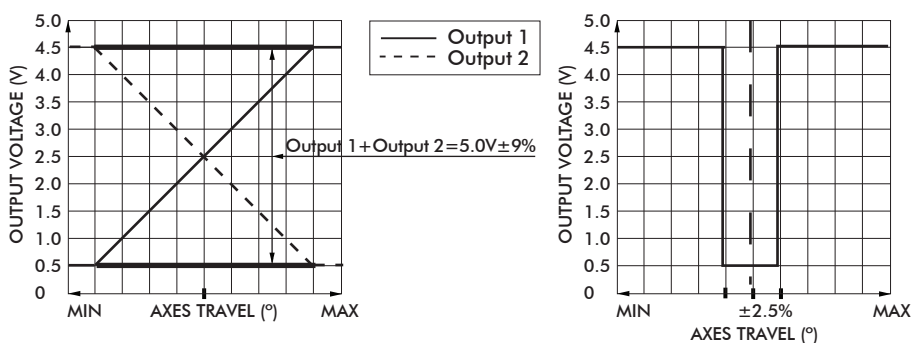

#### ELECTRICAL SPECIFICATIONS

Supply Power	-	4.5VDC to 5.5VDC
Supply Current	-	30mA + 10mA per axis

#### WIRING SPECIFICATION

Red wire	-	Customer power supply 4.5VDC-5.5VDC
Black wire	-	Ground
Blue wire	-	X axis output
Bl/wt wire	-	X axis dual decode logic output
White wire	-	Pushbutton common wire
Orange,violet,gre,y,brown,pink,bl/wt/y/bk,gn/bk,gy/w wire	-	Pushbutton outputs