



Dual Hi-Lo Pressure Switches

Form 217

Dual Hi-Lo pressure switches are rugged field mounted instruments. The pressure sensing assemblies are conventional Static “O” Ring type. The main difference is that two sensing assemblies share a common process pressure port, housing and electrical conduit connection. Two discrete sensing assemblies provide independently adjustable, fine resolution Set Points that can be calibrated to the same actuation point or split to the full span of the adjustable range without interaction.

Design and specifications are subject to change without notice.

Application Information

The Dual Hi-Lo pressure switches in this catalog consolidate control, alarm and safety shutdown applications into one instrument.

For hazardous locations, a hermetically sealed explosion proof stainless steel switching element capsule (DPDT or SPDT) is provided for each sensing assembly. Explosion proof capsules are UL Listed and CSA Certified. The housing can be opened for field calibration without interrupting electrical service.

For nonhazardous locations, a UL Recognized and CSA Approved DPDT or SPDT switching element is provided for each sensing assembly. The NEMA 4, 4X & IP65 housing also includes a standard terminal strip for ease of wiring.

The Static “O” Ring type sensing assemblies provide a wide selection of wetted materials for process compatibility and containment.

With a locally provided external relay, the Dual Hi-Lo can function as an on/off or lock-in/lockout adjustable dead band instrument. For wide adjustable dead band without an external relay, see Form 281.

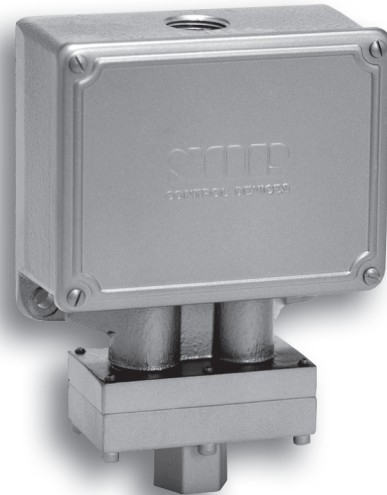

V1: Nonhazardous locations



V2: Hazardous locations

Features and Benefits

Built-in Quality

- Rigid quality standards maintained from raw material to finished product.

Field Adjustable Set Points

- Full range adjustability. No-charge factory calibration.

Robust Construction

- High cycle rate tolerance, long life, not critical to vibration.

Cost Effective

- Simple, fast installation without special tools, long service life, no required periodic service or spare parts. Installation of one Dual Hi-Lo provides two pressure switches in the time normally required for the installation of one pressure switch.

Instrument Quality

- High resolution of Set Points, high repeatability, narrow dead band, negligible temperature effect, high overrange and proof pressures, exceptionally long service life.

Delivery

- Routine shipments 7 to 10 working days. Emergency shipments via air within one day.

Service

- Factory service engineers and area factory representatives provide effective and prompt worldwide service.

Warranty

- 3 years from the date of manufacture.

Dual Hi-Lo Pressure Switches

Principle

V1 Housing for Non-Hazardous Service

V2 Housing for Hazardous Service

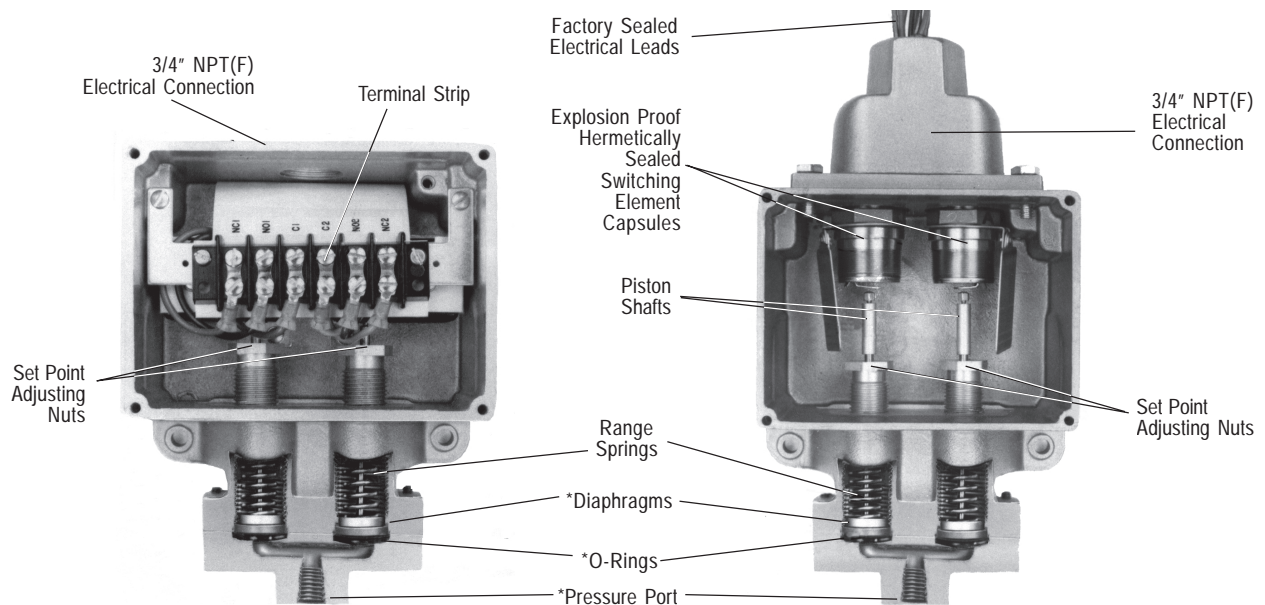

Pressure applied to the Dual Hi-Lo pressure switch is routed to two separate pressure sensing assemblies, thereby eliminating Set Point interaction associated with mechanical linkage. Each pressure sensing element of the Dual Hi-Lo Static "O" Ring Pressure Switch is a force-balanced, piston-actuated assembly sealed by a flexible diaphragm and an o-ring that is static. The only wetted parts are the single pressure port, the two diaphragm and the two o-rings. (See asterisks * in illustration above.) A wide selection of wetted materials is available.

Media pressure on the areas of the pistons counteracts the forces of the range springs (each adjustable by a separate and independent nut), and moves the respective piston shaft only a few thousandths of an inch to directly actuate the respective electrical snap-action switching element. This design virtually eliminates friction and its resultant wear.

Model Number System

66 V1-K2-N4-C1A-PP

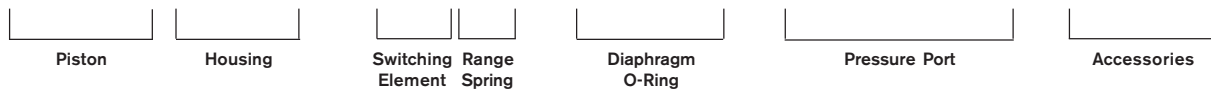

Quick Selection Guide

Basic Dual Hi-Lo pressure switches with standard wetted parts are normally suitable for air, oil, water and noncorrosive process applications in hostile environments. Refer to the Quick Selection Guide section on page 5 for a basic model number. Corrosive service and particular customer requirements may require optional components. Refer to How to Order section to build a customized model number or the dedicated page to locate optional components, such as: switching elements, diaphragm systems, pressure ports and accessories. Each position in the model number, except Accessories, must have a designator.

Applications

The Dual Hi-Lo pressure switches in this catalog are suitable for a wide variety of process applications. Specific application requirements can normally be met by selecting optional components, such as, switching elements and diaphragm systems. Certain applications may require customized specials. Consult area SOR representative or the factory.

Weathertight and hermetically sealed explosion proof models are presented in this catalog.

High pressure fluid power (hydraulic) applications where high shock pressure and high cycle rates are expected normally required pivot seal type pressure switches. Refer to Form 219.

How To Order

Information and data in this catalog are formatted to provide a convenient guide to assist instrument engineers, plant engineers and end users in selecting pressure switches for their unique applications.

Steps 1 through 5 are required. Step 6 is optional. Orders must have complete model numbers, i.e. each component must have a designator.

- Step 1:** Select **Piston-Spring** adjustable range/Set Point from specifications (pages 6 and 7). (Piston/spring combination determines adjustable range.)
- Step 2:** Select **Housing**. Weathertight or explosion proof/weathertight (page 8).
- Step 3:** Select electrical **Switching Element** for electrical service (page 9).
- Step 4:** Select **Diaphragm and O-Ring** for process compatibility and containment (page 10).
- Step 5:** Select **Pressure Port** for process compatibility and connection (page 11).
- Step 6:** Select **Accessories** required for service (page 11).

If Agency Listed, Certified or Listed pressure switches are required, see page 12 for components that must be specified.

Dual Hi-Lo Pressure Switches

Quick Selection Guide

Basic Dual Hi-Lo pressure switches with standard wetted parts are normally suitable for air, oil, water and noncorrosive process in hostile environments. The Set Point must be within the adjustable range. Refer to How to Order section on page 4 to locate optional components. Each position in the model number, except Accessories, must have a designator.

Pressure Switches

Model Number Non-Hazardous Locations NEMA 4, 4X, IP65	Adjustable Range Increasing Pressure psi	Typical Dead Band		Model Number Hazardous Locations Class I, Group A, B, C, D; Class II, E, F, G; Division 1 & 2
		K Switch psi	EF Switch psi	
44V1- K2 - N4 - B1A	2 to 8	0.2	0.6	44V2 - EF2 - N4 - B1A
44V1- K4 - N4 - B1A	2 to 25	0.3	0.9	44V2 - EF4 - N4 - B1A
44V1- K5 - N4 - B1A	3 to 50	0.4	1.2	44V2 - EF5 - N4 - B1A
44V1- K45 - N4 - B1A	4 to 75	0.5	1.5	44V2 - EF45 - N4 - B1A
66V1- K2 - N4 - B1A	7 to 30	0.5	1.5	66V2 - EF2 - N4 - B1A
66V1- K3 - N4 - B1A	12 to 100	0.9	2.7	66V2 - EF3 - N4 - B1A
66V1- K5 - N4 - B1A	20 to 180	1.4	4.2	66V2 - EF5 - N4 - B1A
66V1- K45 - N4 - B1A	25 to 275	1.9	5.7	66V2 - EF45 - N4 - B1A
55V1- K3 - N4 - B1A	25 to 240	2.2	6.6	55V2 - EF3 - N4 - B1A
55V1- K5 - N4 - B1A	35 to 375	3.1	9.3	55V2 - EF5 - N4 - B1A
55V1- K45 - N4 - B1A	45 to 550	3.9	11.7	55V2 - EF45 - N4 - B1A
99V1- K4 - N4 - B1A	100 to 500	5.3	15.9	99V2 - EF4 - N4 - B1A
99V1- K5 - N4 - B1A	200 to 1000	9.2	27.6	99V2 - EF5 - N4 - B1A
99V1- K45 - N4 - B1A	200 to 1750	15	45	99V2 - EF45 - N4 - B1A
11V1- K45 - N4 - C1A	500 to 4000	98	294	11V2 - EF45 - N4 - C1A

Vacuum Switches

Model Number Non-Hazardous Locations NEMA 4, 4X, IP65	Adjustable (Vacuum-o-Pressure) in. Hg.	Typical Dead Band		Model Number Hazardous Locations Class I, Group A, B, C, D; Class II, Group E, F, G; Division1 & 2
		K Switch	EF Switch	
74V1- K117 - N4 - B1A	15 - 0 - 15	0.5	0.5	74V2 - EF117 - N4 - B1A
74V1- K118 - N4 - B1A	30 - 0	0.5	1.5	74V2 - EF118 - N4 - B1A

Piston Disignator	Overrange (psi)	Proof (psi)
44, 74	750	1000
66, 55	1500	2500
99	2500	3900
11	4600	4600

Standard Construction

- Housing: V1, V2-Copper-free aluminum. See housing (page 8) and dimensions (pages 14 & 15) for details.
- Switching element: K: SPDT 15a 250 VAC; EF-SPDT 5 a 250 VAC. See switching element page 9 for optional switching elements.
- Diaphragm & o-ring: N4-Primary (wetted) diaphragm TCP; o-ring (wetted) Buan-N. See diaphragm and o-ring page 10 for optional diaphragm and o-ring systems.
- Pressure port: B1A-Aluminum 1/4" NPT(F). See pressure port page 11 for optional pressure ports.
- Note that the typical dead band column is divided to show different values for the K switching element in the V1 housing and the EF switching element in the V2 housing.
- Ambient temperature range: -30 to 180°F (-34 to 80°C). Check restrictions page 9 for optional electrical switching elements and page 10 for optional diaphragms systems.

Dual Hi-Lo Pressure Switches

Step 1: Specification Pressure

66V1-K2-N4-C1A-PP

This table lists piston/spring combinations for corresponding adjustable ranges, dead bands, overranges and proof pressures. Adjustable range is expressed for increasing pressure; the Set Point must be within the adjustable range. Dead band is expressed as typical. See dead band considerations at the bottom of page 8.

Piston-Spring	Adjustable Range		Typical Dead Band (Vacuum Mode)		Overrange Pressure		Proof Pressure	
	psi	bar [mbar]	psi	bar [mbar]	psi	bar	psi	bar
44 - 2	2 to 8	[140 to 550]	0.2	[15]	750	50	1000	70
44 - 4	2 to 25	0.14 to 1.7	0.3	[20]				
44 - 5	3 to 50	0.2 to 3.5	0.4	[30]				
44 - 45	4 to 75	0.3 to 5	0.5	[35]				
66 - 2	7 to 30	0.5 to 2	0.5	[35]	1500	100	2500	170
66 - 3	12 to 100	0.8 to 7	0.9	[60]				
66 - 5	20 to 180	1.4 to 12	1.4	[95]				
66 - 45	25 to 275	1.7 to 19	1.9	0.15				
55 - 3	25 to 240	1.7 to 16	2.2	0.15				
55 - 5	35 to 375	2.4 to 26	3.1	0.2	2500	170	3900	270
55 - 45	45 to 550	3.1 to 38	3.9	0.25				
99 - 4	100 to 500	7 to 35	5.3	0.4				
99 - 5	200 to 1000	14 to 70	9.2	0.6	4600	320	4600	320
99 - 45	200 to 1750	14 to 120	15	1				
11 - 45	500 to 4000	35 to 275	98	7				

Dual Hi-Lo Pressure Switches

Step 1: Specification Compound/Vacuum

74V1-K117-N4-C1A-PP

This table lists piston-spring combinations for corresponding adjustable ranges, dead bands, overrange and proof pressures. Dual Hi-Lo vacuum switches are compound; they will operate in either vacuum or pressure modes.

Adjustable range is expressed from maximum vacuum decreasing to zero gauge and increasing to maximum pressure. The Set Point must be within the adjustable range. Dead band is expressed as typical. See dead band considerations on bottom of page 8. A vacuum switch is generally better suited than a pressure switch for Set Points very near zero gauge.

Piston-Spring	Adjustable Range (Vacuum - 0 - Pressure)		Typical Dead Band (Vacuum Mode)		Overrange		Proof	
	in. Hg	bar	in. Hg	[mbar]	psi	bar	psi	bar
74 - 117	15 - 0 - 15	0.5 - 0 - 0.5	0.5	[17]	750	50	1000	70
75 - 118	30 - 0	1.0 - 0						

Notes

- Dead band values are expressed as typical expected at mid-range with the standard K switching element assembly installed. When optional switching elements are specified, corresponding dead band multipliers shown on page 8 must be applied.
- Dual Hi-Lo pressure switches can be provided with mixed adjustable ranges. (Requires Accessory Option TT.) For example:
 Left adjustable range: 7 to 30 psi
 Right adjustable range: 25 to 275 psi
 Consult factory for special model number.
- Diaphragm may have an additional effect on dead band. Consult factory. See Notes on page 9.
- Metric bar (mbar) values are practical equivalents of the reference English values; not necessarily exact mathematical conversions. This data appears on the product nameplate when metric engineering units are specified.

Dual Hi-Lo Specification-Pressure

Step 2: Housing
66V1-K2-N4-C1A-PP

Service	Description	Designator
Non-Hazardous Locations	Electrical conduit connection 3/4" NPT(F). NEMA 4, 4X, IP65. Material: Alloy 356 copper-free aluminum.	V1
Hazardous Locations UL Listed CSA Certified SAA Approved Note 2 Snap Switch	Housing contains UL Listed, CSA Certified and SAA Approved snap switch for hazardous locations and hostile environments. See details Note 2, page 8. Electrical conduit connection 3/4" NPT(F). NEMA 4, 4X, & IP65. Material 356 copper-free aluminum.	V2

Notes

1. Check switching element group-housing compatibility below before selecting element. See page 9 for switching element details.
2. Consult the factory for availability of SAA Approved units.

Housing Compatibility

Switching Element Group Housing Designator V1	Switching Element Group Housing Designator V2
A, AA, B, BB, C, E, EE, G, H J, JJ, K, KA, L, S, T, W, Y	AF, AG, EF, EG, JF, JG

Dead Band Considerations

1. Dead band values are expressed as typical expected at midrange using the standard K switching element. When optional switching elements are specified, corresponding dead band multipliers must be applied.
2. Dead bands are fixed (nonadjustable), except when T or H switching elements are used.
3. Dead band can be adjustable by selecting T or H switching element. (Not available when piston designator is 11 or 99.)
4. Dead band multipliers must be applied to the typical dead band values shown in the specification tables whenever optional switching elements other than K, KA or W are used.
5. Dead band can be widened by selecting an optional switching element with a multiplier greater than 1.0.

Example:

Model 66V1-G5-N4-C1A-PP

Typical standard dead band 1.2 psi

G-Switching element multiplier = 3.0

Corrected typical dead band $1.2(3) = 3.6$ psi

Switching Element Designators	Dead Band Multiplier
K, KA, W	1.0
E, J, Y	1.5
A, B, EF, G	3.0
JF, L	3.5
AF, EE	4.0
C, JJ, S	5.0
EG	5.5
AA, BB, JG	6.0
AG	8.5
T adjustable	2.5 to 6.5
H adjustable	1 to 3

Dual Hi-Lo Pressure Switches

Step 3: Switching Element

66V1-K2-N4-C1A-PP

Cross reference compatibility chart on page 8 to ensure that switching element will fit in housing.

Switching Element Service	Housing Designator	Electrical Connection	AC Rating		DC Rating Resistive			Dead Band Multiplier		Designator		
			Volts	Amps	Volts	Amps	Volts	Amps	SPDT	DPDT	SPDT	DPDT
Conventional Switching Elements (See Note 1)												
Normal Service AC	V1	Terminal Block	250	15	125	.4*	30	5*	1.0	-	K	N/A
Low Power Gold Contacts			125	1	-	-	28	1*	1.0	-	KA	N/A
Wide Dead Band AC			125	1	-	-	30	1	1.5	5.0	J	JJ
AC or DC			250	15	-	.5	-	-	3.0	-	G	N/A
Wide Dead Band DC			250	11	125	.5*	30	5.0	3.0	6.0	A	AA
Narrow Dead Band DC			250	15	125	.5	-	-	3.5	-	L	N/A
Very Wide Dead Band DC			250	5	125	.5*	30	5.0*	1.5	4.0	E	EE
Very High Capacity DC Magnetic Blow-Out			250	15	125	.5	-	-	5.0	-	C	N/A
Hi Ambient Temperature Rating - 400°F			125	10	125	1.5 Minimum 10.0 Maximum	-	-	5.0	-	S	N/A
Wide Adjustable Dead Band			250	5	125	.3	-	-	3.0	6.0	B	BB
Narrow Adjustable Dead Band			250	5	125	.5*	-	-	1.5	-	Y	N/A
			250	5	125	.3*	-	-	1.0	-	W	N/A
			250	15	125	.4*	-	-	2.5 to 6.5	-	T	N/A
	250	15	-	-	-	-	1 to 3	-	H	N/A		
Hermetically Sealed Switching Element Capsules (See Note 2)												
AC or DC	V2	18" 18 AWG color-coded wire leads 1/2" NPT(M) conduit connection	250	11	125	.5*	30	5.0	4.0	8.5	AF	AG
Narrow Dead Band DC			250	5	125	.5*	30	5.0*	3.0	5.5	EF	EG
Low Power Gold Contacts			125	1	-	-	30	1	3.5	6.0	JF	JG

Notes

- AC/DC electrical ratings for switching elements K, KA, J, JJ, G, A, AA, L, E, EE, C, S, B, BB, Y, W, T & H (used in the V1 housing) are UL Recognized and CSA Certified.
- The hermetically sealed switching element capsule is UL Listed, CSA Certified and SAA Approved as an explosion proof snap switch per the table below.

Agency	Hazardous Location Conditions	Designator
UL Listed	Class I, Group A, B, C, D; Class II, Group E, F & G; Division 1 & 2	AF, EF, AG, EG, JF, JG
CSA Certified		
SAA Approved	Ex s IIC T6 IP65 Class I, Zone 1 DIP T6 IP65	AF, EF, AG, EG

- DC electrical ratings are for resistive loads only. Those marked with an asterisk (*) are not agency recognized or certified but have been verified by testing or experience.

- Switching element ambient temperature limits:

Temperatures:

-40 to 167°F (-40 to 75°C) AF, AG, EF, EG, JF, JG

-65 to 400°F (-54 to 204°C) B, Y, W

-65 to 250°F (54 to 120°C) A, E, J

-65 to 180°F (-54 to 80°C) All others

- Dead band multipliers must be applied to the typical dead band figures given in the specification tables on page 8.

- Switching Elements W & Y have an Elgiloy spring.

- DPDT is 2-SPDT. See Glossary of Terms on page 13.

CAUTION: The switching element assembly has been precisely positioned in the housing at the factory for optimum performance. Any inadvertent movement or replacement in the field will degrade performance, could render the device inoperative, and can void the warranty unless factory authorized procedures are followed.

Dual Hi-Lo Pressure Switches

Step 4: Diaphragm & O-Ring

66V1-K2-N4-C1A-PP

Notes

1. N4 diaphragm system is standard. It is normally suitable for air, oil, water and noncorrosive processes.
2. Other diaphragm and o-ring combinations may be available. Consult the factory or the SOR representative in your area for more information.
3. Wetted parts have been selected as representing the most suitable commercially available material for use in the service intended. However, they do not constitute a guarantee against corrosion or permeation, since processes vary from plant to plant and concentration of harmful fluids, gases or solids vary from time to time in a given process. Empirical experience by users should be the final guide. Alternate materials based on this are generally available.
4. Specify N3 diaphragm system for high cycle rate, high shock applications where Buna-N and TCP are compatible with the process.

O-Ring Material	°F	°C
Viton	32 to 400	0 to 204
Viton GLT	-20 to 400	-29 to 204
Kalrez	0 to 400	-18 to 204
Aflas	25 to 400	-4 to 204
Buna-N		
Neoprene	-30 to 200	-34 to 93
EPR		
TCP-Teflon Coated Polyimide Diaphragm	-30 to 400	-34 to 204

5. This table shows allowable minimum and maximum temperatures for o-rings.
6. Dead bands are slightly higher when using H, J, N6, N3, or W series diaphragm options. Consult factory.
7. M9 diaphragm system is suggested for steam applications up to 400°F.
8. If Kalrez, EPR or Viton is selected for high-temperature process media or ambient temperature requirements, the A, B, E, J, W or Y switching elements are suggested with reference to the table in Note 4, page 8.

O-Ring (Wetted)	Diaphragm (Wetted Primary)	Designator	
Viton	Monel	A4	
Kalrez		A6	
Viton	Hastelloy B	H4	
Kalrez		H6	
Viton	Hastelloy C	J4	
Kalrez		J6	
Viton	Carpenter 20	L4	
Kalrez		L6	
Viton GLT	316L SS	M1	
Buna-N		M2	
Viton		M4	
Neoprene		M5	
Kalrez		M7	
Aflas		M8	
EPR		M9 (See Note 7)	
Viton		TCP Teflon-Coated Polyimide	N1
Buna-N			N3 (See Note 4)
Buna-N	N4 Standard (See Note 1)		
Kalrez	N5		
Kalrez	N6		
EPR	TCP Teflon-Coated Polyimide	N7	
Aflas		N8	
Buna-N	Buna-N	P1	
Neoprene	Neoprene	R1	
Viton	Viton	S1	
Viton GLT		S2	
Buna-N	Tantalum	W2	
Viton		W4	
Neoprene		W5	
Kalrez		W6	
EPR Ethylene Propylene	EPR Ethylene Propylene	Y1	

Dual Hi-Lo Pressure Switches

Step 5: Pressure Port Material & Connection Systems

66V1-K2-N4-C1A-PP

Material	Connection	Designator
Aluminum Alloy 356 copper-free casting	1/4" NPT(F)	B1A*
	1/2" NPT(F)	B2A*
316SS CF-8M Casting	1/4" NPT(F)	C1A
	1/2" NPT(F)	C2A

Note

*Aluminum pressure port (B1A, B2A) not available for 500 to 4000 psi adjustable range (Piston Designator 11).

Step 6: Accessories

66V1-K2-N4-C1A-PP

Accessory / Option & Description	Designator
Wetted Parts are cleaned for industrial oxygen service.	BB
CSA Certified pressure/vacuum switch. See agency listings page 12.	CS
Universal terminal box. Stainless steel. FM Approved and CSA Certified. (V2 housing only.) (SPDT only.)	HT
Vacuum protector plate. Retains diaphragm in pressure switch if subjected to vacuum greater than 15 in. Hg. Material matches or exceeds pressure port material.	MM
Stainless steel piston and cylinder disc for higher overrange and proof. Consult factory.	PC
Pipe (stanchion) mounting kit for (1-1/2 or 2" pipe). Order as a separate line item for CSA Certified pressure switches.	PK
Tag, fiber. Attached with plastic wire to housing. Stamped with customer specified tagging information.	PP
Tag, stainless steel. Attached with stainless steel wire to housing. Stamped with customer specified tagging information. (2 lines, 18 characters and spaces per line.)	RR
Explosion proof and weathertight electrical junction box with screw terminals. 3/4" NPT(F) top or right conduit connections as required. UL Listed and CSA Certified Class I, Groups A, B, C & D; Class II, Group E, F & G; Divisions 1 and 2. Includes cover oring for weathertight applications. (V2 housing only.) (SPDT only.)	TB
Oversize stainless steel nameplate or separate stainless steel tag. Permanently attached to housing. Stamped with customer specified tagging information.	TT
Fungicidal varnish. Covers exterior and interior except working parts.	VV
Epoxy coating. Exterior only. Polyimide epoxy with 316SS pigment.	YY
Chained cover with captive screws to conform to former JIC specification.	ZZ
"X" is used as a suffix to the model number for special requirements not keyed elsewhere in the model number by an "X". Each "X" must be completely identified in the text of the order or inquiry. When more than one "X" is required, use "X" followed by the number of such items. For example, "X3" means three separate otherwise unidentifiable requirements.	X

Dual Hi-Lo Pressure Switches

Shipping Weights

Actual shipping weights may vary from the charted values because of product material, configuration and packaging requirements.

V1Housing	V1 Housing	Accessory	Add (lbs)	(kgs)
4 lbs (2 kgs)	5 lbs (2.5 kgs)	PK Pipe Kit	1.5	0.7
		TB Junction Box with Terminal Block	5	2.25

Agency Listings

The following combinations only are available as approved, certified or listed by the agencies shown. Some components are for products not offered in this catalog. Certain components or combinations may acquire additional approval, certification or listing between print dates of this catalog. Contact the factory for the most current information.

CSA

Enclosure 4 (weathertight)

Piston	Housing	Switching Element	Diaphragm Spring	Pressure Port & O-Ring Material	Connection Size	Accessories/Option
All	V1	A, AA, B, BB, C, E, EE, G, H, J, JJ, K, KA, L, S, T, W, Y	All	All	All	CS Required

Class I, Group A, B, C, D; Class II, Group E, F, G; Enclosure 4X

Piston	Housing	Switching Element	Diaphragm Spring	Pressure Port & O-Ring Material	Connection Size	Accessories/Option
All	V2	AF, AG, EF, EG, JF, JG	All	All	All	CS Required All except TB

SOR recognizes that there is no industry convention with respect to terminology and definitions pertinent to pressure switches. This glossary applies to SOR Dual Hi Lo Pressure Switches.

Adjustable Range

The span of pressure between upper and lower limits within which the pressure switch can be adjusted to actuate/deactuate. It is expressed for increasing pressure.

Dead Band

The difference in pressure between the increasing Set Point and the decreasing Set Point. It is expressed as typical, which is an average with the increasing Set Point at mid range for a pressure switch with the standard K switching element. It is fixed (nonadjustable) unless T or H switching element is specified.

Hermetically Sealed

A welded steel capsule with glass-to-metal, factory-sealed, electrical leads that isolates the electrical switching element(s) from the environment.

Overrange

The maximum input pressure that can be continuously applied to the pressure switch without causing permanent change of Set Point, leakage or material failure.

Pressure Switch

A bi-stable electromechanical device that actuates/deactuates one or more electrical switching element(s) at a predetermined discrete pressure/vacuum (Set Point) upon rising or falling pressure/vacuum.

Proof Pressure

The maximum input pressure that can be continuously applied to the pressure switch without causing leakage or catastrophic material failure. Permanent change of Set Points may occur, or the device may be rendered inoperative.

Repeatability

The ability of a pressure switch to successively operate in Set Point that is approached from a starting point in the same direction and returns to the starting point over three consecutive cycles to establish a pressure profile. The closeness of the measured Set Point values is normally expressed as a percentage of full scale (maximum adjustable range pressure).

Set Point

That discrete pressure at which the pressure switch is adjusted at actuate/deactuate on rising or falling pressure. It must fall within the adjustable range and be called out as increasing or decreasing pressure.

SPDT Switching Element

Single-Pole, Double Throw (SPDT) has three connections: C-Common, NO-Normally Open and NC-Normally Closed, which allows the switching element to be electrically connected to the circuit in either NO or NC state.

DPDT Switching Element

DPDT is two synchronized SPDT switching elements which actuate together at increasing Set Point and deactuate together at decreasing Set Point. Discrete SPDT switching elements allow two independent circuits to be switched; i.e., one AC and one DC.

The synchronization linkage is factory set, and is not field adjustable. Synchronization is verified by connecting test lamps to the switching elements and observing them go "On" simultaneously at actuation and "Off" simultaneously at deactuation.

Dual Hi-Lo Pressure Switches

Dimensions

Dimensions in this catalog are for reference only. They may be changed without notice. Contact the factory for certified drawings for a particular model number. Dimensions are expressed as millimeters over inches. Design and specifications are subject to change without notice (Linear = mm/in.).

Non-Hazardous Locations - Weathertight NEMA 4, 4X, IP65

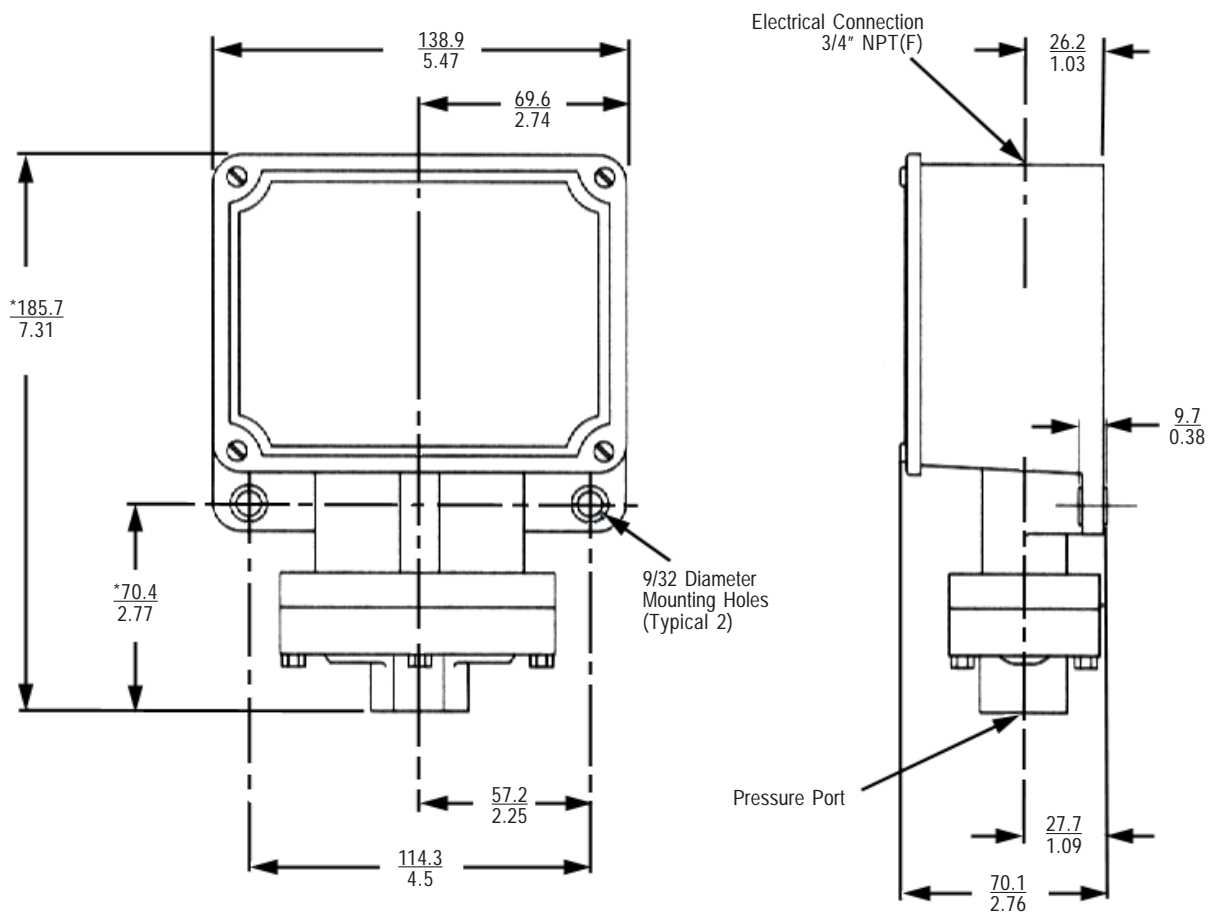

*Add $\frac{6.4}{.25}$ for all non-aluminum ports.

Housing Designator: V1

Dual Hi-Lo Pressure Switches

Dimensions

Dimensions in this catalog are for reference only. They may be changed without notice. Contact the factory for certified drawings for a particular model number. Dimensions are expressed as millimeters over inches. Design and specifications are subject to change without notice (Linear = mm/in.).

Hazardous Locations

Contains Explosion Proof, Hermetically Sealed Switching Element Capsule: UL Listed, CSA Certified Class I, Groups A, B, C, D; Class II, Group E, F, G; Divisions 1 & 2

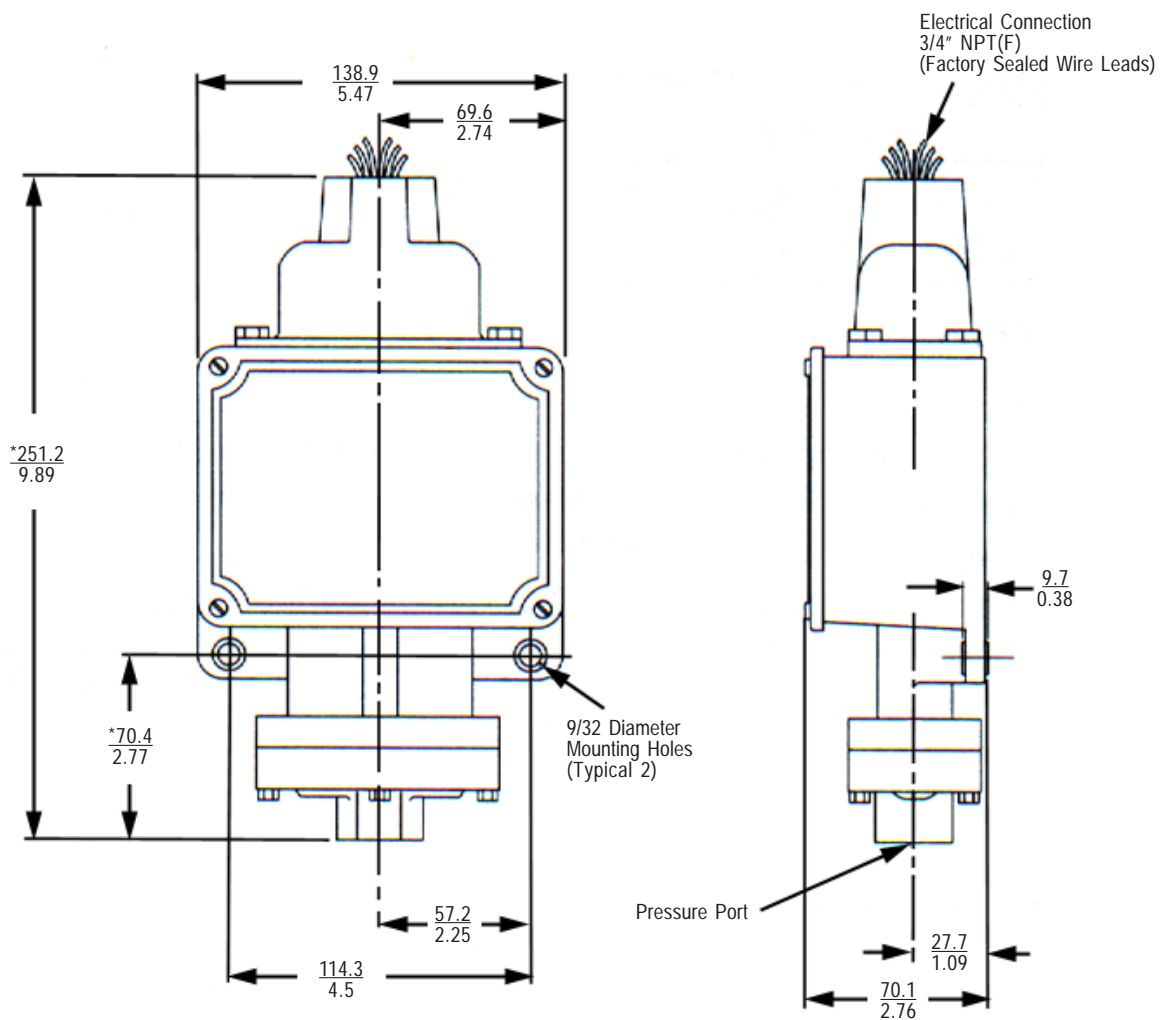

*Add $\frac{6.4}{.25}$ for all non-aluminum ports.

Housing Designator: **V2**



Process Instrumentation

SOR INC.

14685 West 105th Street
Lenexa, Kansas 66215

Phone 913-888-2630
Toll Free 800-676-6794
Fax 913-888-0767

www.sorinc.com

Registered Quality System to ISO 9001