



Adjustable Dead Band Pressure Switches

Form 281

The adjustable dead band pressure switch should be used when there is a requirement for an adjustable and wide dead band between the increasing and decreasing set points.

Function

Alarm: Hi – Lo

Control: On – Off

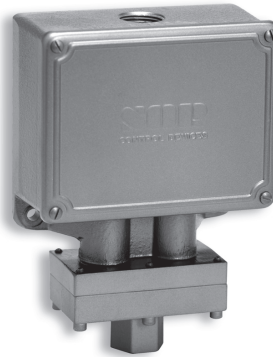

V1 Weathertight Housing



V3 Weathertight Explosion Proof Hermetically Sealed Switches

Features and Benefits

- Wide adjustable dead band
- Independent adjustments for increasing and decreasing Set Points
- Field adjustable with fine resolution of Set Points
- Instrument quality – high repeatability
- High overrange and proof pressures
- Exceptionally long life
- Not critical to vibration
- Wide selection of wetted parts materials for process compatibility and containment

Adjustable Dead Band Pressure Switches

Principle

The SOR Adjustable Dead Band pressure switch incorporates two industry proven Static “O” Ring pressure sensing elements. Media pressure on the areas of the pistons counteracts the forces of the range springs – each adjustable by a separate adjusting nut – and moves the piston shafts to operate the lever assembly which, in turn, actuates and deactuates the electrical switching element. Each pressure sensing element of the Adjustable Dead Band pressure switch is a force balance piston-actuated assembly sealed by a flexible diaphragm and an o-ring that is static. The only wetted parts are the single pressure port, two diaphragms, and two o-rings all indicated with asterisks (*) in this illustration.

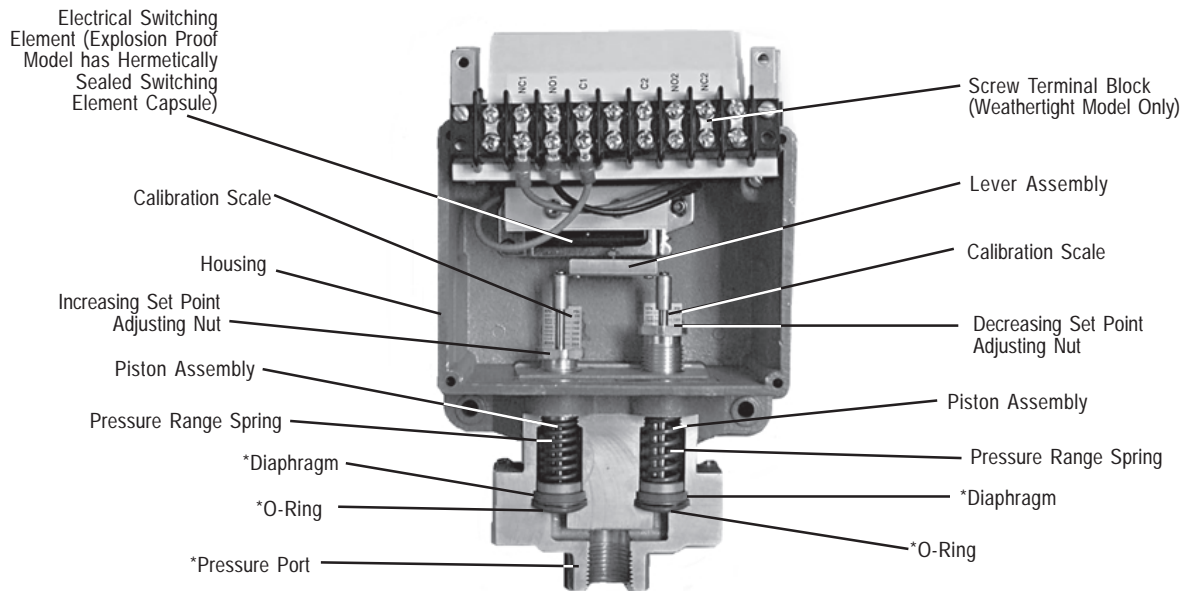

Principle Schematic

The lever assembly travel illustrated here has been exaggerated for clarity.

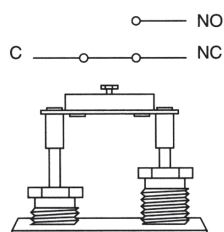

No Pressure: Electrical switching element is deactuated.

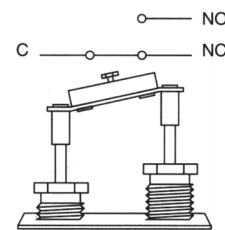

Pressure greater than decreasing Set Point but less than increasing Set Point. Electrical switching element remains deactuated.

Actuation

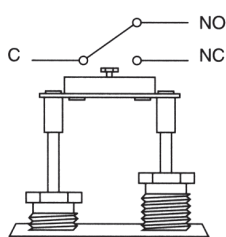

Pressure equal to or greater than increasing Set Point: Electrical switching element is actuated.

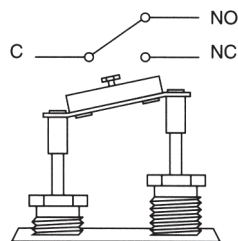

Pressure less than increasing Set Point but greater than decreasing Set Point: Electrical switching element remains actuated.

Deactuation

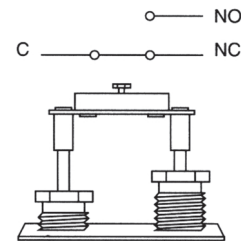

Pressure equal to or less than decreasing Set Point: Electrical switching element is deactuated.

Model Number System

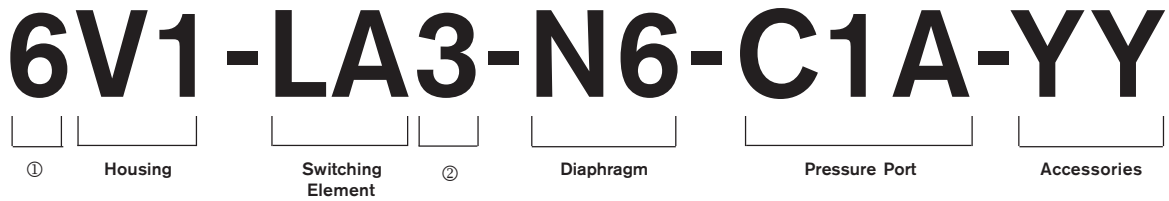

How to Order

Information and data in this catalog are formatted to provide a convenient guide to assist instrument engineers, plant engineers and end users in selecting pressure switches for their unique applications.

Steps 1 through 5 are required. Step 6 is optional. Orders must have complete model numbers, i.e. each component must have a designator.

Step 1: Select **Adjustable Range** from pages 4, 5 and 6 to fill in ① and ②.

Step 2: Select **Housing**. Weathertight or explosion proof/weathertight (page 6).

Step 3: Select electrical **Switching Element** for electrical service (page 7).

Step 4: Select **Diaphragm and O-Ring** for process compatibility and containment (page 8).

Step 5: Select **Pressure Port** for process compatibility and connection (page 9).

Step 6: Select **Accessories** required for service (page 9).

If Agency Approved, Certified or Listed pressure switches are required, see page 10 for components that must be specified.

Adjustable Dead Band Pressure Switches

Step 1: Adjustable Range

5V1-LA3-N6-C1A-YY

Six adjustable dead band ranges are available. Each adjustable range is displayed on a grid (pages 5 and 6). Determine the correct adjustable range for the application by checking increasing and decreasing Set Point requirements against the tables. In the example below, a contact closure is required when pressure increases to 160 psi. The same contact must open when pressure decreases to 60 psi. Since 60 psi is within the blue field, the example grid range is correct for the application.

When the correct range grid is selected, insert range designators ① and ② from that grid into the model number.

Step 1

Find the specified increasing Set Point at the top of the graph.

Step 2

Find the specified decreasing Set Point along the left edge of the graph.

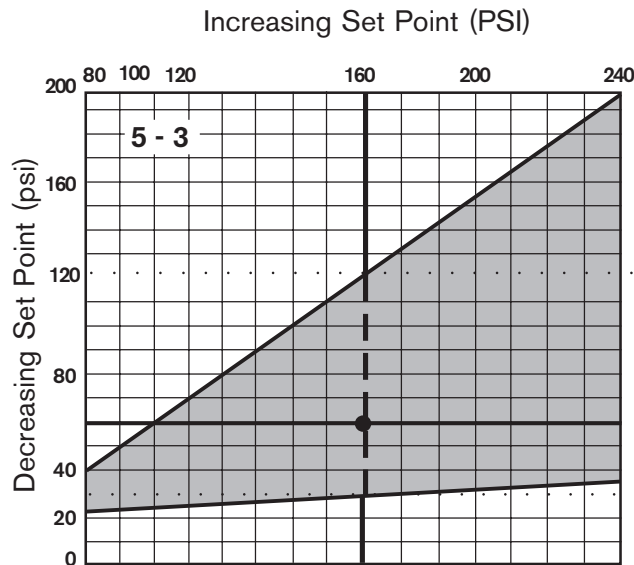

Step 3

Following the vertical line down from the increasing Set Point. Follow the horizontal line across from the decreasing Set Point. Any point within the blue field is acceptable.

① 5 ② 3

5V1-LA3-N6-C1A-YY

1st and 4th places in model number

Adjustable Dead Band Pressure Switches

Step 1: Adjustable Range

5V1-LA3-N6-C1A-YY

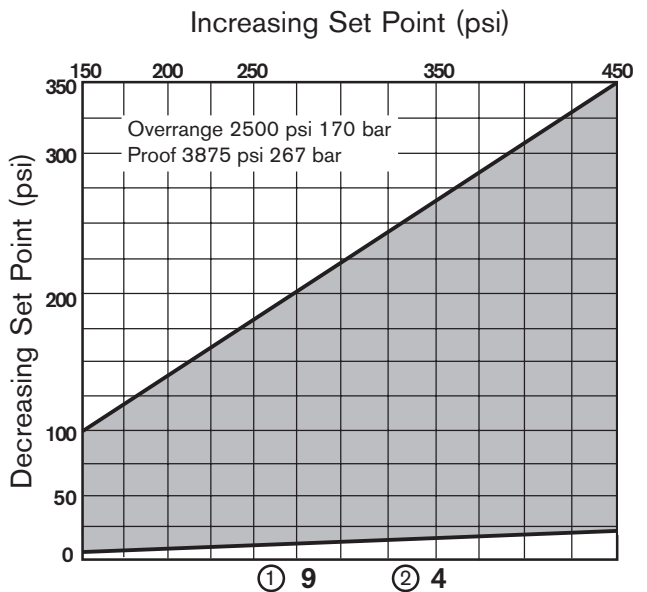
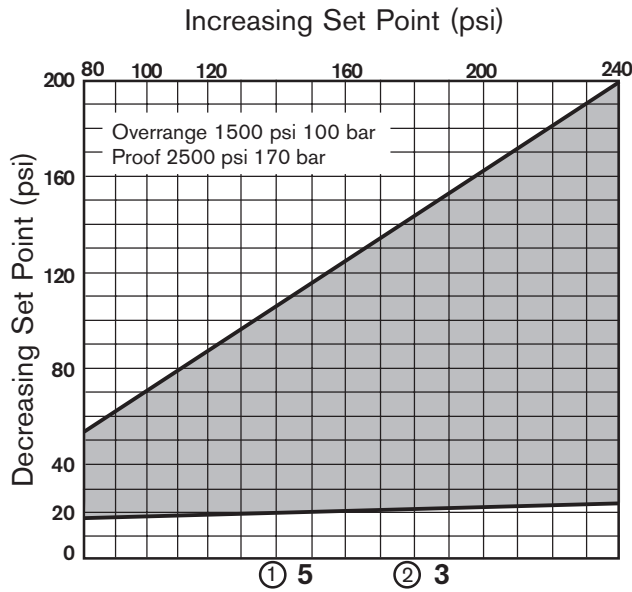
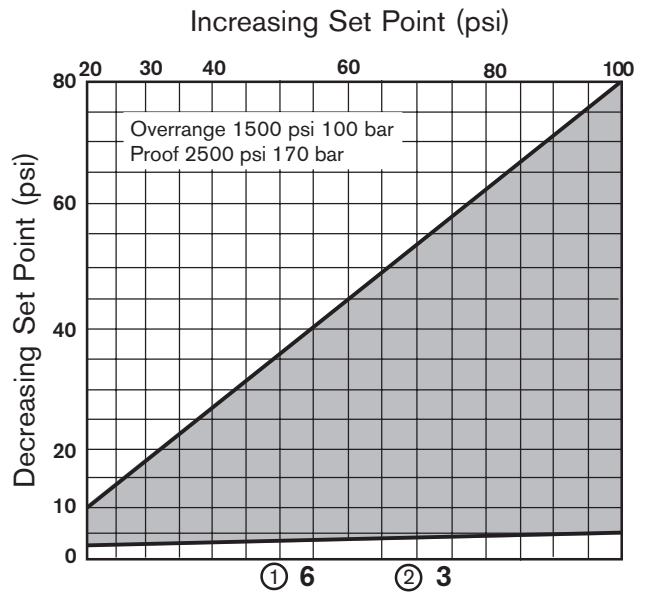
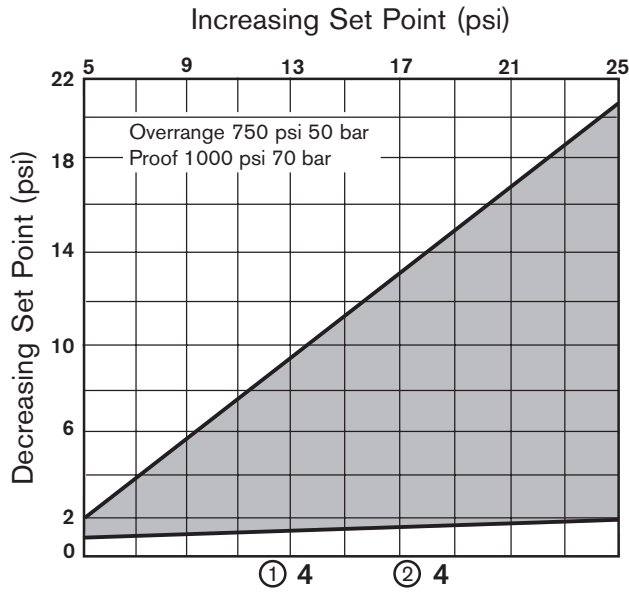

Adjustable Dead Band Pressure Switches

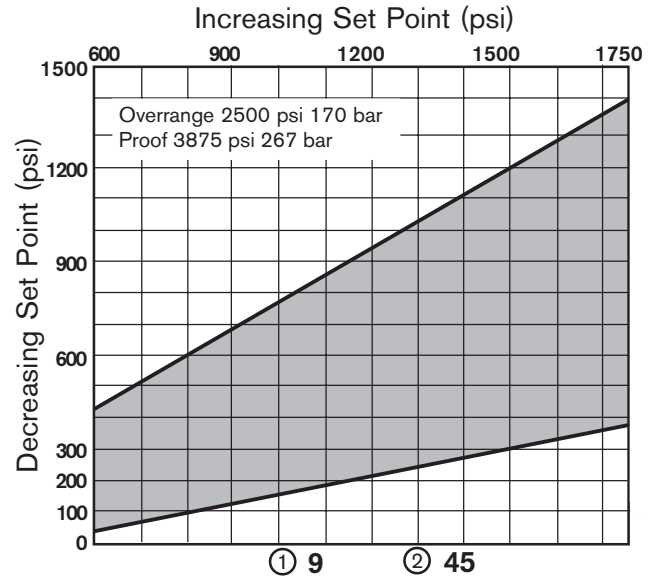
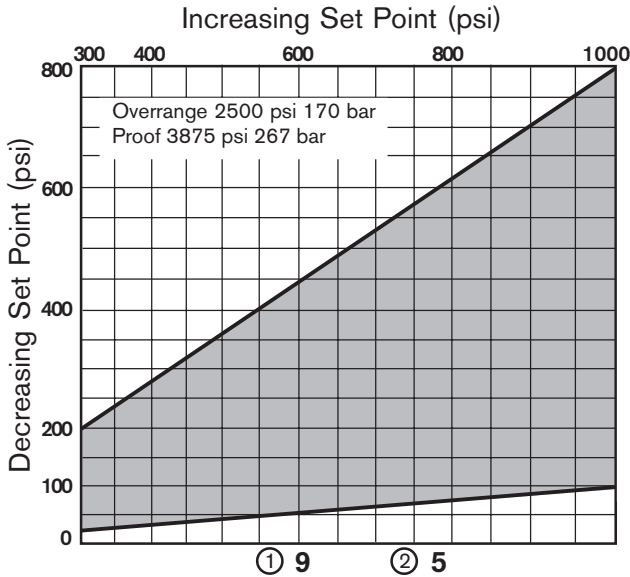

Step 1: Adjustable Range

5V1-LA3-N6-C1A-YY



Step 2: Housing

6V1-LA3-N6-C1A-YY

Service	Description	Designator
Non-Hazardous Locations	<p>Weathertight for non-hazardous service. NEMA 4, 4X & IP65 Electrical conduit connection: 3/4" NPT(F) Material: 356 aluminum Use LA or SA switching element and terminal block. Shipping weight: 4 pounds (2 kgs) See cutaway view on page 2; dimensions on page 14.</p> 	V1
Hazardous Locations (UL Listed/CSA Certified Snap Switch)	<p>Explosion proof and weathertight. NEMA 4, 4X & IP65. Class I, Group A, B, C, D; Class II, Group E, F, G; Division 1 & 2 Electrical conduit connection: 3/4" NPT(F) Material: 356 aluminum Use AG switching element; hermetically sealed SS capsule Shipping weight: 5 pounds (2.5 kgs)</p> 	V3

Adjustable Dead Band Pressure Switches

Step 3: Switching Elements

6V1-LA3-N6-C1A-YY

Switching Element Service	Contact Form	Electrical Connection Type	AC Rating		DC Rating Resistive				Maximum Ambient Temperature		Designator	
			Volts	Amps	Volts	Amps	Volts	Amps	Deg F	Deg C	SPDT	DPDT
Normal Service AC	SPDT	Screw Terminal Block	250	15	125	.5	30	10*	180	80	LA	N/A
Very High Capacity DC Magnetic Blow-out			125	10	125	1.5 Minimum 10.0 Maximum	-	-	180	80	SA	N/A
AC or DC	DPDT	18" 18 AWG color-coded wire leads 3/4" NPT(M) conduit connection	250	11	125	.5*	30	5.0	160	70	N/A	AG

1. The switching elements shown above are UL Listed and CSA Certified. The DC current rating marked (*) is not UL Listed but has been verified by testing and/or experienced.
2. The hermetically sealed switching element capsule is UL Listed, CSA Certified and SAA Approved as a snap switch in accordance with the following table.

Agency	Hazardous Location Condition	Designator
UL Listed	Class I, Group A, B, C, D; Class II, Group E, F, G; Division 1 & 2	AG
CSA Certified		
SAA ^{Note 3} Approved	Ex x IIC T6 for Class 1, Zone 1 DIP Type B 80°C for Class II, Division 1 & 2	

3. Consult the factory for availability of SAA Approved units.

Adjustable Dead Band Pressure Switches

Step 4: Diaphragm and O-Ring

6V1-LA3-N6-C1A-YY

Notes

- N4 diaphragm system is standard. It is normally suitable for air, oil, water and non-corrosive processes.
- Other diaphragm and o-ring combinations may be available. Consult the factory or the SOR representative in your area for more information.
- Wetted parts have been selected as representing the most suitable commercially available material for use in the service intended. However, they do not constitute a guarantee against corrosion or permeation, since processes vary from plant to plant and concentration of harmful fluids, gases or solids vary from time to time in a given process. Empirical experience by users should be the final guide. Alternate materials based on this are generally available.
- Specify N3 diaphragm system for high cycle rate, high shock applications where Buna-N and TCP are compatible with the process.
- This table shows allowable minimum and maximum temperature for o-rings.

O-Ring Material	°F	°C
Viton	32 to 400	0 to 204
Viton GLT	-20 to 400	-29 to 204
Kalrez	0 to 400	-18 to 204
Aflas	25 to 400	-4 to 204
Buna-N Neoprene EPR	-30 to 200	-34 to 93
TCP-Teflon Coated Polyimide Diaphragm	-30 to 400	-34 to 204

- M9 diaphragm system is suggested for steam applications up to 400°F.
- Dead bands are slightly higher when using H, J, W, N3, or N6 series diaphragm options. Consult the factory.

O-Ring (Wetted)	Diaphragm (Wetted Primary)	Designator	
Viton	Monel	A4	
Kalrez		A6	
Viton	Hastelloy B	H4	
Kalrez		H6	
Viton	Hastelloy C	J4	
Kalrez		J6	
Viton	Carpenter 20	L4	
Kalrez		L6	
Viton GLT	316L SS	M1	
Buna-N		M2	
Viton		M4	
Neoprene		M5	
Kalrez		M7	
Aflas		M8	
EPR		M9 (See Note 6)	
Viton		TCP Teflon-Coated Polyimide	N1
Buna-N			N3 (See Note 4)
Buna-N	N4 Standard (See Note 1)		
Kalrez	N5		
Kalrez	Kalrez	N6	
EPR	TCP Teflon-Coated Polyimide	N7	
Aflas		N8	
Buna-N	Buna-N	P1	
Neoprene	Neoprene	R1	
Viton	Viton	S1	
Viton GLT		S2	
Buna-N	Tantalum	W2	
Viton		W4	
Neoprene		W5	
Kalrez		W6	
EPR Ethylene Propylene	EPR Ethylene Propylene	Y1	

Adjustable Dead Band Pressure Switches

Step 5: Pressure Port

6V1-LA3-N6-C1A-YY

Material	Connection	Designator
Aluminum Alloy 356 copper-free casting	1/4" NPT(F)	B1A
	1/2" NPT(F)	B2A
316SS CF-8M Casting	1/4" NPT(F)	C1A
	1/2" NPT(F)	C2A

Step 6: Accessories

6V1-LA3-N6-C1A-YY

Accessory / Option & Description	Designator
Wetted parts are cleaned for industrial oxygen service.	BB
CSA Certified pressure switch. Available with V1 housing. Housing has earth (ground) lug. See agency listings on page 10 for details.	CS
Cemented cover gasket on weathertight housing.	GC
Universal terminal box, 1/2" NPT(F). 316SS. Explosion proof. FM Approved; CSA Certified. See form 657 (Catalog GI-30).	HT
Vacuum protector plate. Retains diaphragm in pressure switch if subjected to vacuum greater than 15 in. Hg. Material matches or exceeds pressure port material.	MM
Compliance to NACE Certification MR0175.	NC
Stainless steel piston and cylinder disc for higher overrange and proof. Consult factory.	PC
Pipe (stanchion) mounting kit for (1-1/2 to 2" pipe). Order as a separate line item for CSA Certified pressure switches.	PK
Tag, fiber. Attached with plastic wire to housing. Stamped with customer specified tagging information.	PP
Tag, stainless steel. Attached with stainless steel wire to housing. Stamped with customer specified tagging information. (2 lines, 18 characters and spaces per line.)	RR
Explosion proof and weathertight electrical junction box with screw terminals. 3/4 "NPT(F) top or right conduit connections as required. UL Listed and CSA Certified Class I, Groups A, B, C & D; Class II, Group E, F & G; Division 1 & 2. Includes cover o-ring for weathertight applications. (V3 housing only.)	TB
Oversize stainless steel nameplate. Permanently attached to housing. Stamped with customer specified tagging information.	TT
Fungicidal varnish. Covers exterior and interior except working parts.	VV
Epoxy coating. Exterior only. Polyimide epoxy with 316SS pigment.	YY
Chained cover with captive screws to conform to former JIC specification.	ZZ
"X" is used as a suffix to the model number for special requirements not keyed elsewhere in the model number by an "X". Each "X" must be completely identified in the text of the order or inquiry. When more than one "X" is required, use "X" followed by the number of such items. For example, "X3" means three separate, otherwise unidentifiable requirements.	X

Adjustable Dead Band Pressure Switches

Agency Listings

The following combinations only are available as approved, certified or listed by the agencies shown. Some components are for products not offered in this catalog. Certain components or combinations may acquire additional approval, certification or listing between print dates of this catalog. Contact the factory for the most current information.

CSA	Enclosure 4 (weathertight)						
	Piston	Housing	Switching Element	Spring	Diaphragm & O-Ring	Pressure Port Material & Connection Size	Accessories/ Option
	All	V1	LA, SA	All	All	All	CS Required All except TB

SOR recognizes that there is no industry convention with respect to terminology and definitions pertinent to pressure switches. This glossary applies to SOR Pressure Switches.

Adjustable Range

The span of pressure between upper and lower limits within which the pressure switch can be adjusted to actuate/deactuate.

Dead Band

The difference in pressure between the increasing Set Point and decreasing Set Point.

Decreasing Set Point

That discrete pressure at which the pressure switch is adjusted to deactuate on falling pressure. It must fall within the adjustable range.

Hermetically Sealed

A welded steel capsule with glass-to-metal, factory-sealed, electrical leads that isolates the electrical switching element(s) from the environment.

Increasing Set Point

That discrete pressure at which the pressure switch is adjusted to actuate on rising pressure. It must fall within the adjustable range.

Overrange

The maximum input pressure that can be continuously applied to the pressure switch without causing permanent change of Set Point, leakage or material failure.

Pressure Switch

A bi-stable electromechanical device that actuates/deactuates one or more electrical switching element(s) at a predetermined discrete pressure/vacuum (Set Point) upon rising or falling pressure/vacuum.

Proof Pressure

The maximum input pressure that can be continuously applied to the pressure switch without causing leakage or catastrophic material failure. Permanent change of Set Point may occur, or the device may be rendered inoperative.

Repeatability

The ability of a pressure switch to successively operate at a Set Point that is approached from a starting point in the same direction and returns to the starting point over three consecutive cycles to establish a pressure profile. The closeness of the measured Set Point values is normally expressed as a percentage of full scale (maximum adjustable range pressure).

SPDT Switching Element

Single-Pole, Double Throw (SPDT) has three connections: C – Common, NO – Normally Open and NC – Normally Closed, which allows the switching element to be electrically connected to the circuit in either NO or NC state.

DPDT Switching Element

DPDT is two synchronized SPDT switching elements which actuate together at increasing Set Point and deactuate together at decreasing Set Point. Discrete SPDT switching elements allow two independent circuits to be switched; i.e., one AC and one DC.

The synchronization linkage is factory set, and is not field adjustable. Synchronization is verified by connecting test lamps to the switching elements and observing them go “On” simultaneously at actuation and “Off” simultaneously at deactuation

Adjustable Dead Band Pressure Switches

Dimensions

Dimensions in this catalog are for reference only. They may be changed without notice. Contact the factory for certified drawings for a particular model number. Dimensions are expressed as millimeters over inches (Linear = mm/in.).

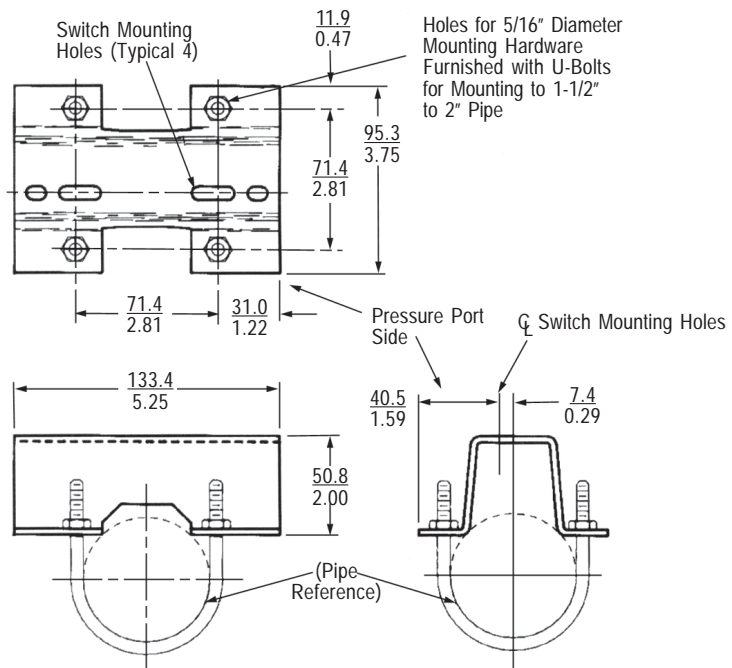

Pipe Mounting Kit: **PK**

Perpendicular Mounting

Parallel Mounting

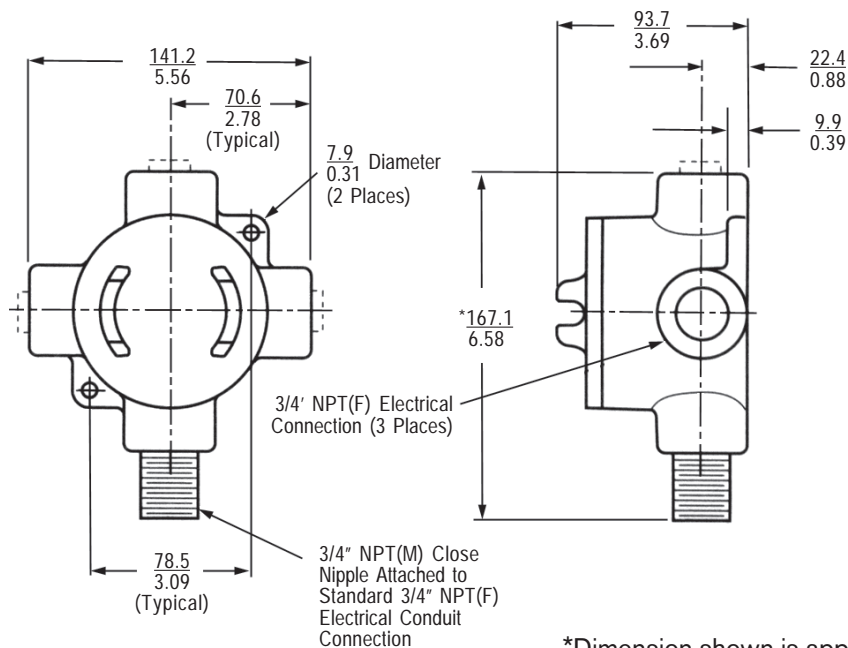

*Dimension shown is approximate and based on a 5-thread engagement.

Junction Box with Terminal Block: **TB**

Adjustable Dead Band Pressure Switches

Dimensions

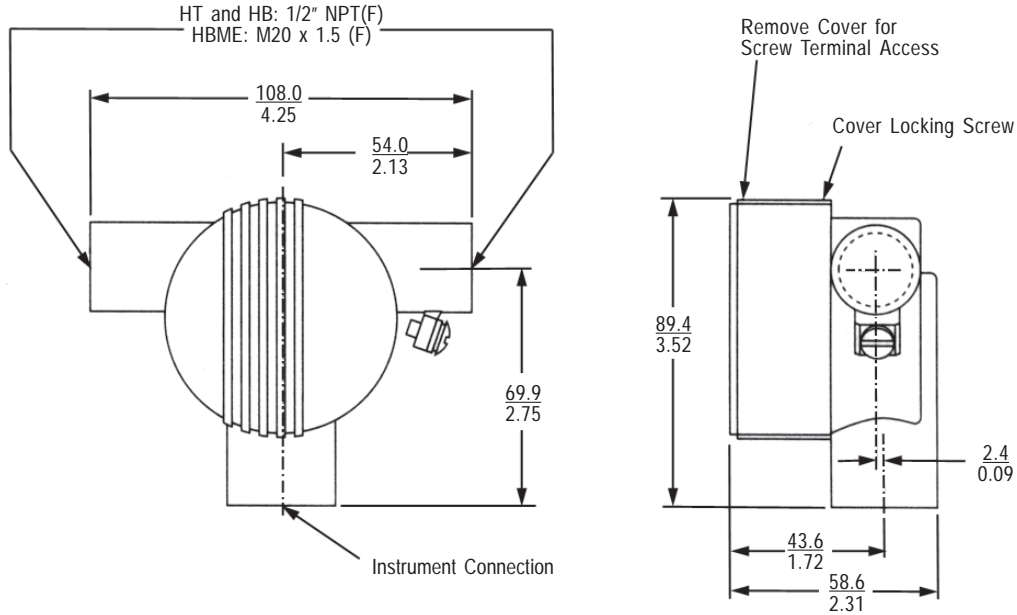

Dimensions shown are for reference only. Contact the factory for certified dimension drawings.

Junction Box with Terminal Block: HT

Shipping Weights

V1 Housing	V3 Housing	Accessory	Add lbs	kgs
4 lbs (2 kgs)	5 lbs (2.5 kgs)	PK Pipe Kit	1.5	0.7
		TB Junction Box with Terminal Block	5	2.25

Actual shipping weights may vary from the charted values because of product material, configuration and packaging requirements.

Adjustable Dead Band Pressure Switches

Housing Dimensions

Dimensions in this catalog are for reference only. They may be changed without notice. Contact the factory for certified drawings for a particular model number. Dimensions are expressed as millimeters over inches (Linear = mm/in.).

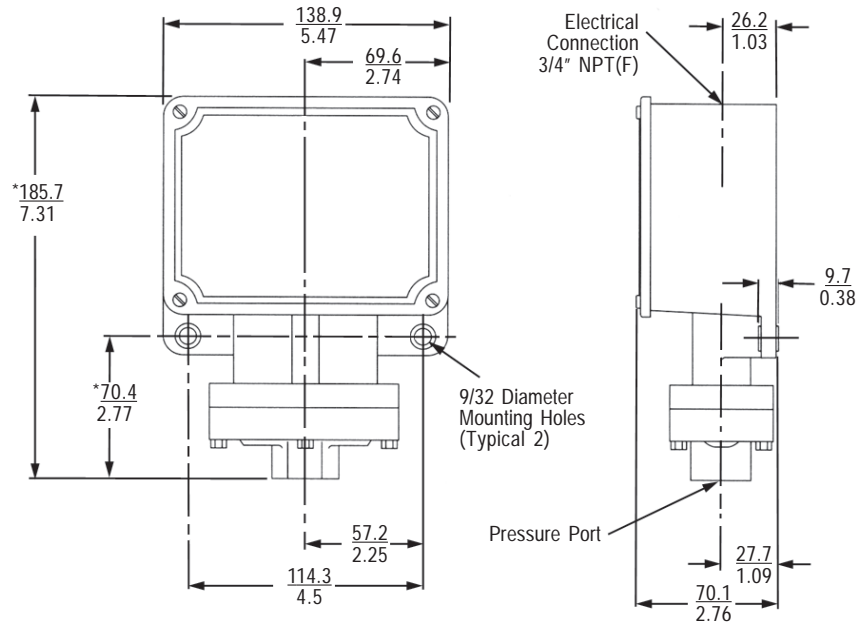

Non-Hazardous Locations
Weathertight NEMA 4, 4X, IP65
Housing Designator: V1

*Add 6.4 for all non-aluminum ports.
 0.25

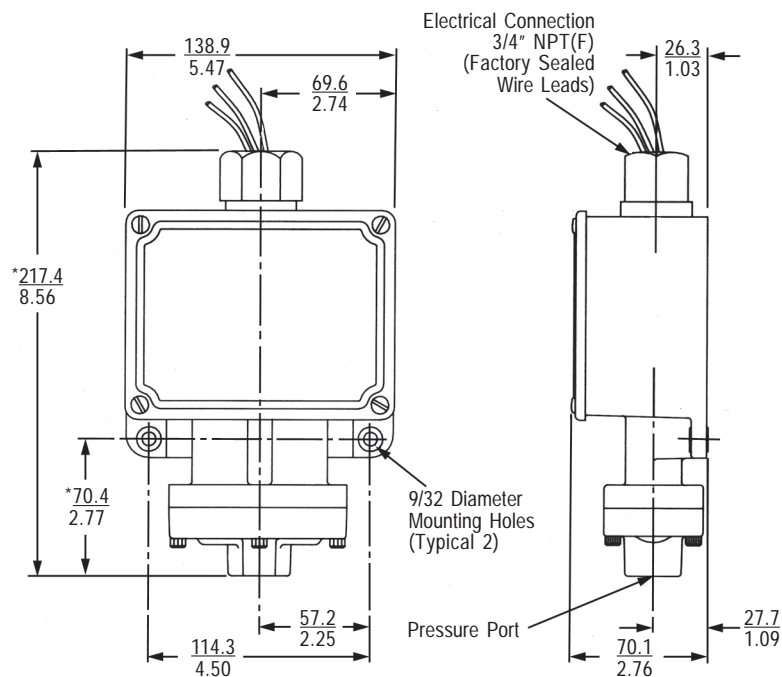

*Add 6.4 for all non-aluminum ports.
 0.25

Hazardous Locations

Contains Explosion Proof, Hermetically Sealed Switching Element Capsule: UL Listed, CSA Certified Class I, Group A, B, C, D; Class II, Group E, F, G; Divisions 1 & 2

Housing Designator: V3



Process Instrumentation

SOR INC.

14685 West 105th Street
Lenexa, Kansas 66215

Phone 913-888-2630
Toll Free 800-676-6794
Fax 913-888-0767

www.sorinc.com

Registered Quality System to ISO 9001

Form 281 (04.02) Printed in U.S.A.