

PMIX (selectable sensor types)

Guided Incremental Linear Encoder

- Alternative to conventional Linear measuring systems (Lengths 200/400/600 mm available)
- LMIX2 or EMIX2 as measuring system available
- Combination with Z15, Z16 or Z17 possible
- Sensor and magnetic tape integrated
- optimal guided & easy to install



1. INTRODUCTION	3
2. THE SENSOR	3
2.1 Functionality of the sampling sensors	3
2.2 Resolution/Edge multiplier	3
3. SUPPLY AND OUTPUT VERSIONS	3
3.1 Voltage drop referring to wire length	4
4. CONNECTIONS OF PMIX	4
6. INSTALLATION	5
6.1 Installation place	5
6.2 Supply voltage	5
6.3 Fault clearance	5
7. DIMENSIONS	5
8. TECHNICAL SPECIFICATIONS	6
00 - Supply / Output level 10 – 30 V / 10 – 30 V HTL	6
01 - Supply / Output level 10 – 30 V / TTL Line Driver	6
11 - Supply / Output level 5 V / TTL Line Driver	6
9. TYPE DESIGNATION	7
10. LIABILITY EXCLUSION / GUARANTEE	8

1. Introduction

PMIX is based on the respective selected encoder type i.e. ELGO LMIX2 (further EMIX2 or battery powered indicator/encoder system like Z15, Z16 or Z17 are possible). With a contactless principal of measuring, it's an alternative to conventional linear measuring systems. The sensor head and the magnetic tape are fixed in a mechanical cylinder and will be optimal guidedl at lengthwise movements. Thus the system can be mounted and installed immediately.

2. The Sensor

2.1 Functionality of the sampling sensors

Integrated in the sensor head are the magneto resistor measuring-bridges as well as the interpolation circuit and the output drivers. The bridge generates the distance dependent count pulses for the signal processing electronic.

The distance between sensor and tape must not be larger than 2.0 mm at LMIX2 resp. 0.8 mm at EMIX2. Every smaller value (0.1 – 2.0 resp. 0.8 mm at EMIX2) is allowed. The sensor cable is an eight wire cable, highly flexible and suitable for tug chains. It consists of twisted pair wires and is shielded.

2.2 Resolution/Edge multiplier

(How to order see page 7 / Point 9 Type designation)

1. With LMIX2 Sensor: 0.1 mm at single edge triggering, resp. 0.025 mm at four edge triggering (Magnetic tape pole distance 5 mm)
2. With EMIX2 Sensor: 0.01 mm at four edge triggering (Magnetic tape pole distance 2 mm)
3. With Z15, Z16 or Z17: 0.1 mm

3. Supply and Output Versions

The following combination of supply and output levels are deliverable:

1. **Order index 00*** = supply voltage **10 - 30 V** / output level **10 - 30 V**
2. **Order index 01*** = supply voltage **10 - 30 V** / output level **TTL Line Driver**
3. **Order index 11*** = supply voltage **5 V** / output level **TTL Line Driver**

** Order index (see page 7 / point 9 type designation)*

Note: To reach the largest possible interference distance it is recommended to supply the magnetic length system PMIX with 10-30 VDC and to select the A/B signals TTL-compatible (5V) (**Index 01**) and to evaluate them differential.

3.1 Voltage drop referring to wire length

(only when supply voltage 5 VDC)

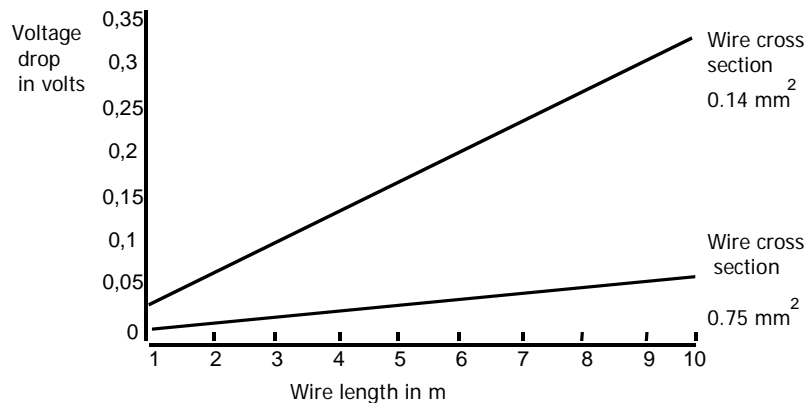

4. Connections of PMIX

	open wires Standard	D-SUB 9 pins Option D1 (ELGO-D-SUB assignment)
Function	Color	Pin no.
0V (GND)	White	1
5VDC/10-30 VDC in	Brown	2
Channel A	Green	3
Channel B	Yellow	4
Channel Z	Black	8
Channel A'	Violet	6
Channel B'	Orange	7
Channel Z'	Gray	9
Shielding	PE \equiv	Connected to housing

6. Installation

6.1 Installation place

The installation place must be at least 0.5 m away from inductive and capacitive interference sources as contactors, relays, engines, switch power pack, clocked controllers, etc. The PMIX cable must principally be wired separately from heavy duty current wires and a distance to interference sources must be kept. The cylinder resp. the magnetic tape must be installed with min. 100 mm distance from other magnets or magnetic fields.

6.2 Supply voltage

The supply voltages must be stabilized DC voltages and should not exceed 5 VDC with a tolerance of $\pm 2.5\%$. Allowed ripple at 10-30 VDC and 5 VDC is: $< 50\text{ mV}$.

6.3 Fault clearance

If there arise interferences in spite of observing all above mentioned points, proceed as follows:

1. Add RC elements over contactor reels of AC contactors (e.g. $0.1\ \mu\text{F}/100\ \Omega$).
2. Add recovery diodes over DC inductances
3. Add RC elements over each engine phase and over the engine brake
4. Use separate power pack for following circuits (e.g. indicator, counter etc.)

7. Dimensions

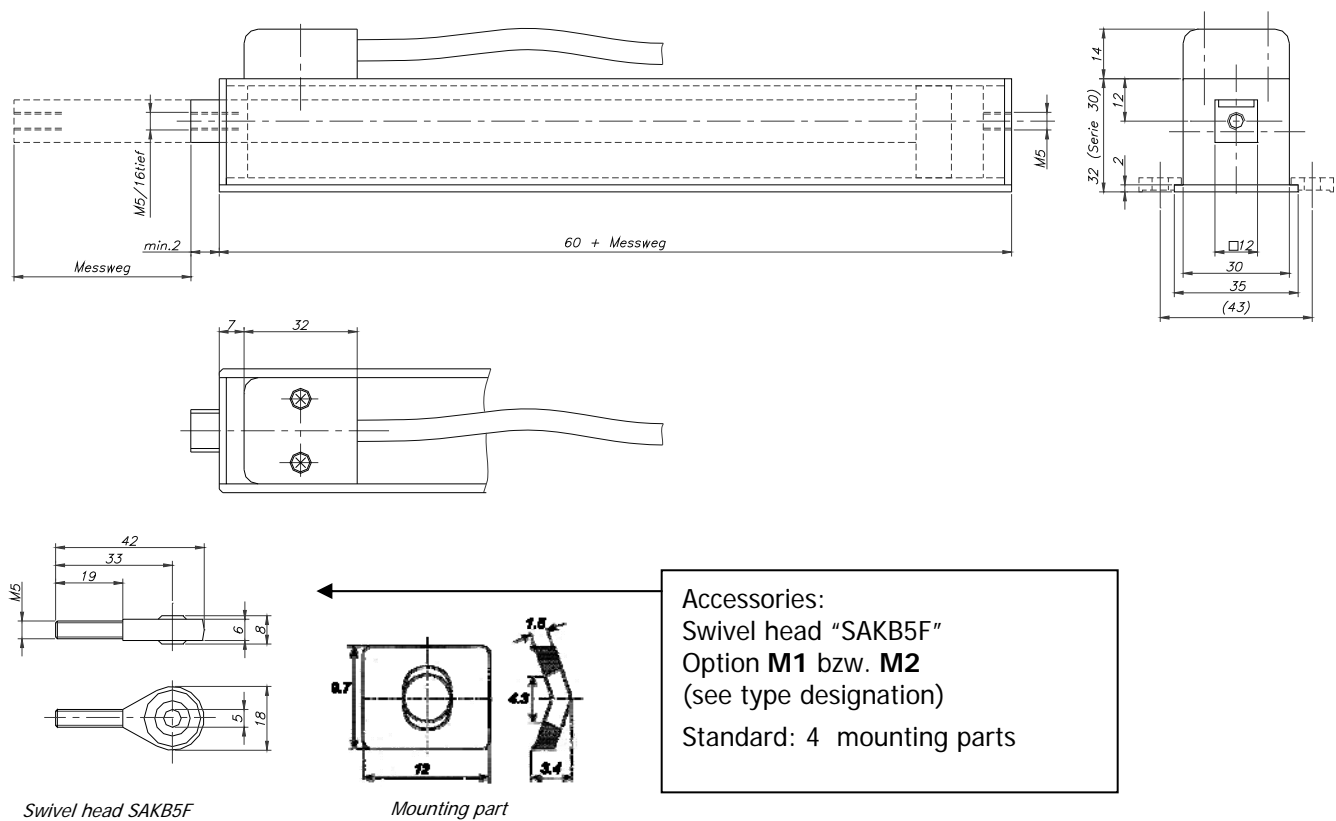

8. Technical specifications

General

Housing	: Cylinder; Aluminium Sensor; Zinc die cast
Protection	: Cylinder IP40 Sensor IP 67
Operate temperature	: -10... +70 °C (-25... +85 °C) auf Anfrage
Output current	: max. 20 mA per channel
Outputs	: push/pull, continuous short circuit proof
Index pulse	: Cycle duration, dependent on operating speed

00 - Supply / Output level 10 – 30 V / 10 – 30 V HTL

Tolerance of supply voltage	: +/- 10%
Consumption	: max.150 mA
Operating speed	: LMIX max. 5.0 m/s at optimal Evaluation EMIX max. 4.0 m/s at optimal Evaluation
max. Length of wire	: 30 m

01 - Supply / Output level 10 – 30 V / TTL Line Driver

Tolerance of supply voltage	: +/- 10%
Consumption	: max. 150 mA
Operating speed	: LMIX max. 5.0 m/s EMIX max. 4.0 m/s
max. Length of wire	: 50 m

11 - Supply / Output level 5 V / TTL Line Driver

Tolerance of supply voltage	: +/- 5%, Ripple <50 mV
Consumption	: max. 200 mA
Operating speed	: LMIX max. 5.0 m/s EMIX max. 4.0 m/s
max. Length of wire	: 10 m

9. Type designation

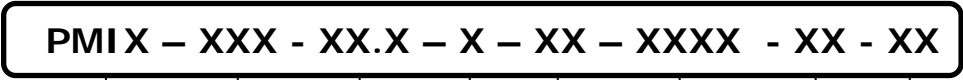

Series/Type

SN-Number

- 000 = Standard
- 001 = first special version
- 002... etc.

Length of signal wire (XX,X m)

- Standard lengths:
- 1, 3, 5, 8 m with LMIX2/EMIX2
 - 1 m with Z15 or Z16
 - others on request

Resolution

- 1 = 0.025 mm (at 4 edge triggering) based on LMIX2
- 3 = 0.01 mm (at 4 edge triggering) based on EMIX2
- 4 = 0.1 mm with Z15
- 5 = 0.1 mm with Z16

Supply/output level

- 00 = 10-30 VDC/10-30 VDC
- 01 = 10-30 VDC/ 5 V-TTL line driver
- 11 = 5VDC/ 5V-TTL line driver

*** Length of cylinder (effective measuring length)**

- 0200 = 200 mm
- 0400 = 400 mm
- 0600 = 600 mm
- Others on request

Options

- D1 = 9 pin D-SUB-Connector (PIN-assignment in ELGO-Standard)

Montage

- M0 = Without swivel heads, with 4 mounting parts (**Standard**)
- M1 = With 1 swivel head SAKB5F and 4 mounting parts
- M2 = With 2 swivel heads SAKB5F, without mounting parts

* It is to be noted that always 60 mm must be added to the measuring length.
 For example if a PMIX with 200 mm is ordered, then the total length amounts to 260 mm.

10. Liability exclusion / Guarantee

We have checked the contents of this instruction manual carefully, to the best of our knowledge and belief for conformity with the described hardware and software. Nevertheless errors, mistakes or deviations can not be excluded, therefore we do not guarantee complete conformity. Necessary corrections will be included in the subsequent editions.

We appreciate your ideas and improvement suggestions very much. Reprint, duplication and translation, even in extracts, are only allowed with a written authorization by the company ELGO Electric GmbH. We constantly strive for improving our products, therefore we keep all rights reserved for any technical modifications without any notice. ELGO Electric does not assume any liability for possible errors or mistakes.

The guarantee period is one calendar year from the date of delivery and includes the delivered unit with all components. ELGO Electric GmbH will at its option replace or repair without charge defects at the unit or the included parts, verifiable caused by faulty manufacturing and/or material in spite of proper handling and compliance to the instruction manual.

Damages verifiably not caused by ELGO Electric GmbH and due to improper handling are excluded from any guarantee e.g. by applying faulty voltage, diffusion of liquid into the interior of the engine, using force, scratching the surface, chemical influences etc.!

Subject to modifications ©ELGO Electric GmbH 2005

ELGO - Electric - GmbH
Measure - Control - Position
Carl - Benz - Straße 1, D-78239 Rielasingen
phone.: 0049-7731/93 39 - 0, Fax: 2 88 03
Internet: www.elgo.de, Mail: info@elgo.de

