

MSA 770, MSA 870

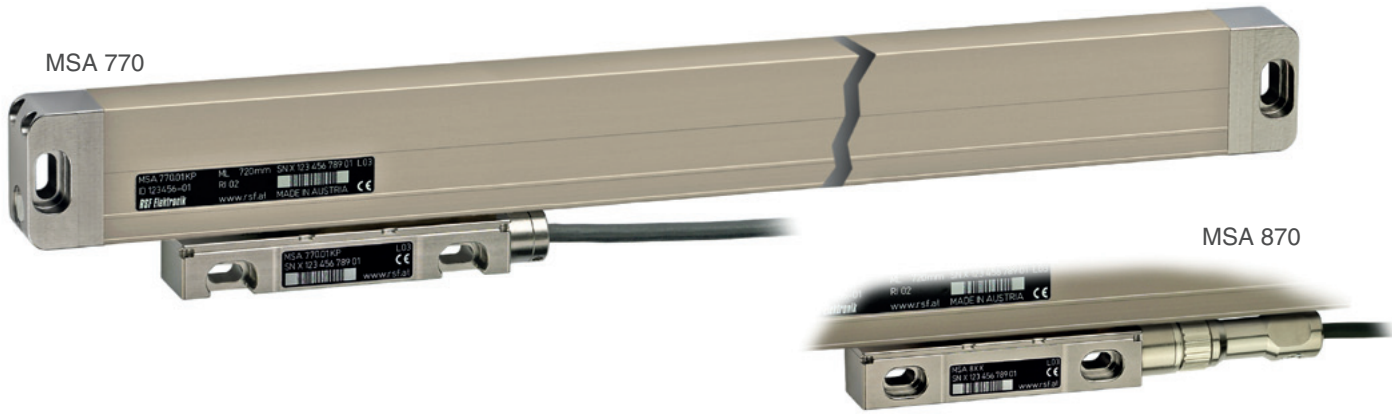

Dimensions, mounting tolerances MSA 770:

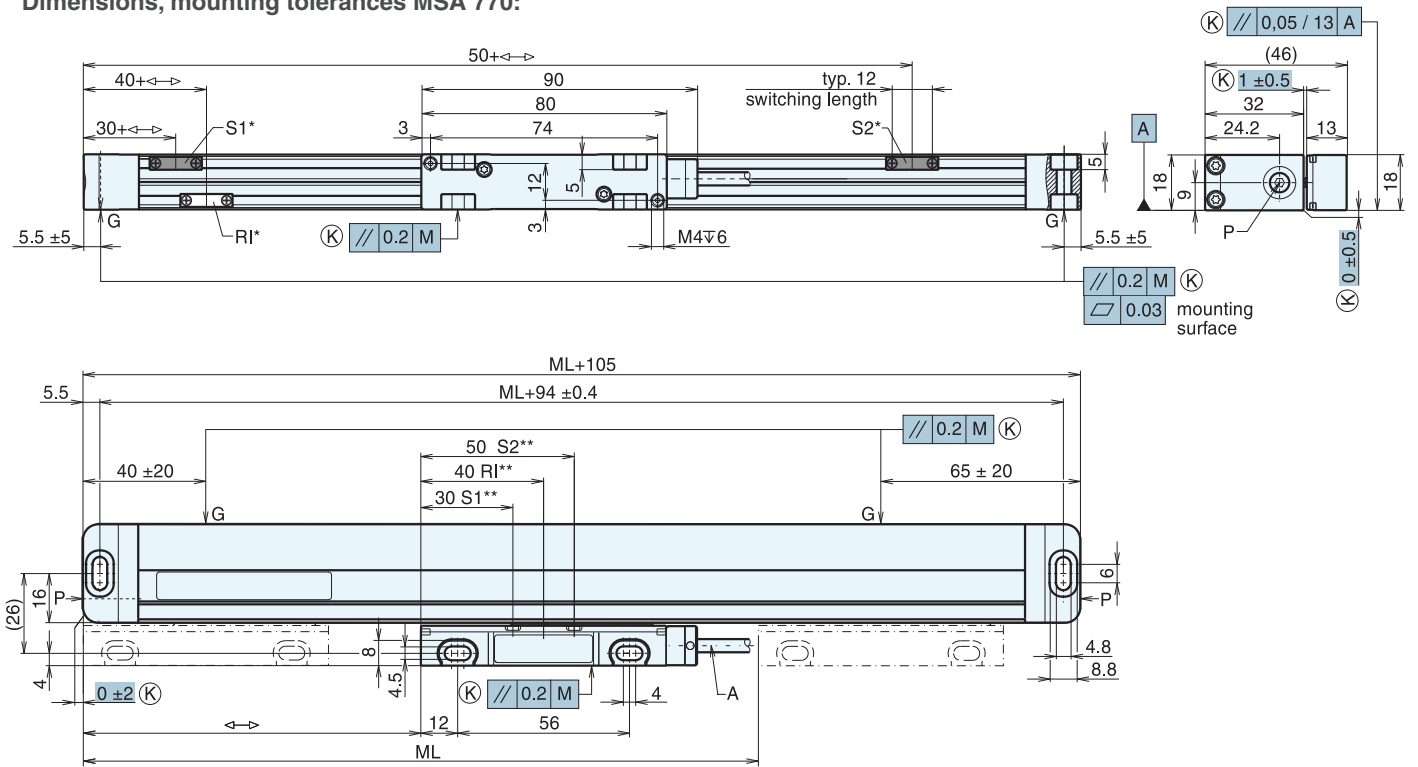

Dimensions, mounting tolerances MSA 870:

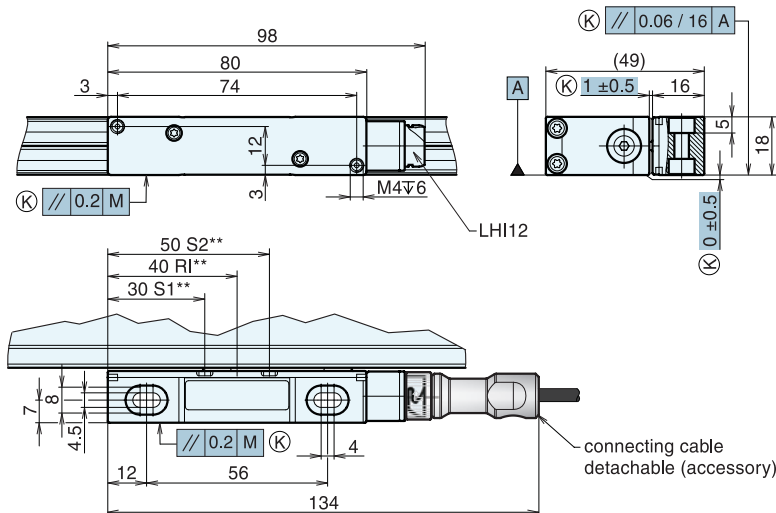

- M = machine guideway
- ML = measuring length
- G = gauging points
- ↔ = 0 ... ML
- A = cable
- LHI12 = male connector
- Ⓚ = customer mounting dimensions
- optional:
- P = M5 air inlet
- S1, S2 = switch signals
- RI = selectable reference mark
- * = actuator magnet
- ** = sensor position