

## MSA 710, MSA 810

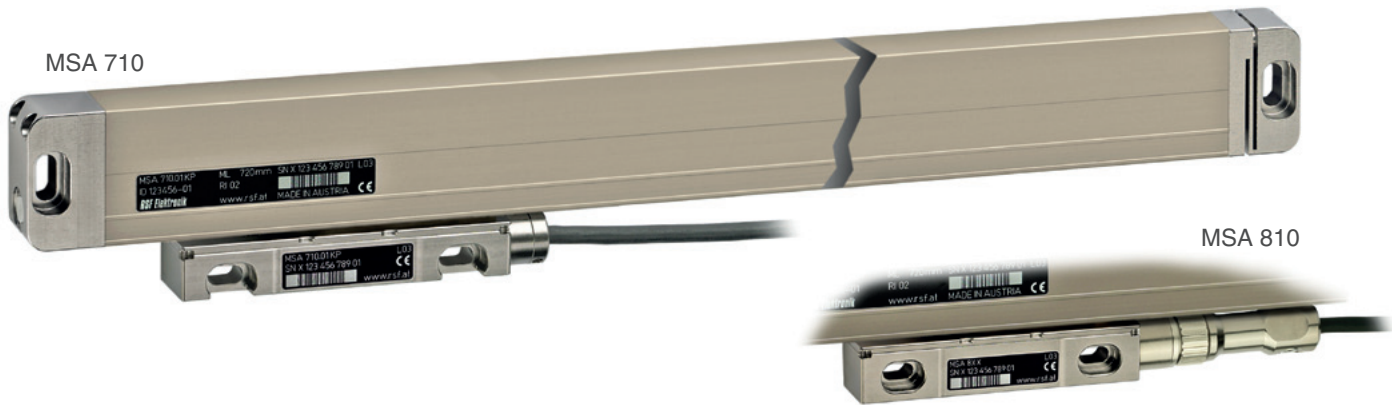

### Dimensions, mounting tolerances MSA 710:

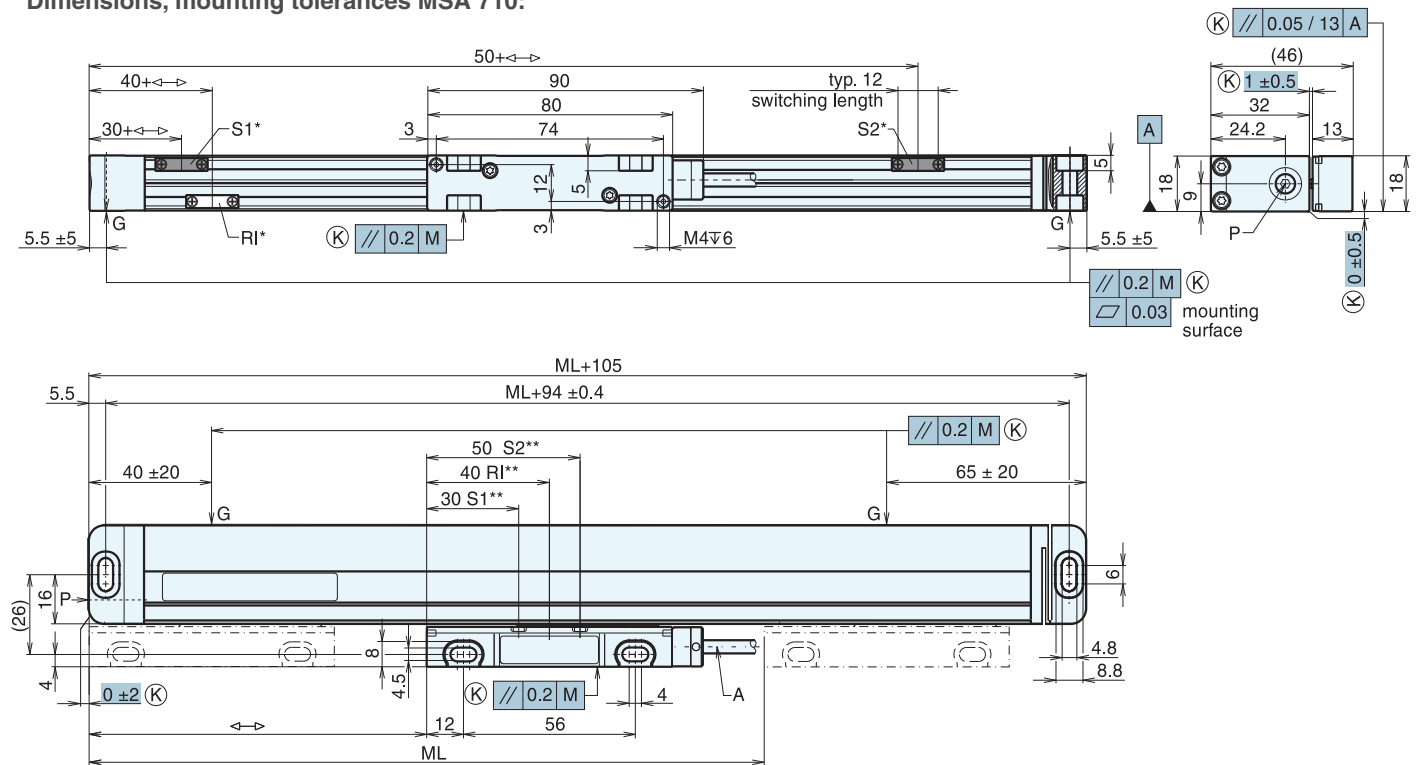

### Dimensions, mounting tolerances MSA 810:

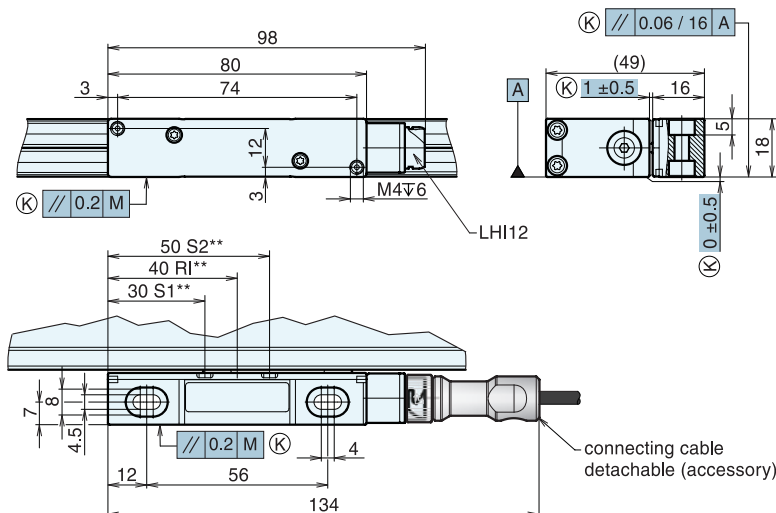

- M = machine guideway
- ML = measuring length
- G = gauging points
- ↔ = 0 ... ML
- A = cable
- LHI12 = male connector
- (K) = customer mounting dimensions
- optional:
- P = M5 air inlet
- S1, S2 = switch signals
- RI = selectable reference mark
- \* = actuator magnet
- \*\* = sensor position