



RACTRON
ELECTRONICS

深圳市瑞科创电子有限公司

地址：广东深圳市福田区上步南路1001号锦峰大厦A座3楼308-312室
电话：0755-83062006 82767281 82767282 82767283 32971587
传真：0755-83004913 www.ractron.com bojillsheng@ractron.com.cn

石英晶体谐振器 Crystal Resonators HC-49 SMD DATASHEET

	项目	Item	规格
1	标称频率	Nominal Frequency	3MHz - 86MHz
2	外壳尺寸	Holder Type	HC-49 SMD
3	振动模式	Mode of Vibration	Fundamental 基频/AT 3 rd overtone 三次泛音/AT
3	拐点温度	Turnover Temperature	25°C ± 5°C
4	频率精度	Frequency Tolerance @ 25°C	±10ppm ± 15ppm ±20ppm ± 30ppm ±50ppm ±100ppm
5	工作温度	Operating Temperature	- 0°C ~ +50°C -10°C ~ +60°C -10°C ~ +70°C -20°C ~ +70°C -30°C ~ +80°C -40°C ~ +85°C
6	温度频差	Freq Stability vs. Temp	±10ppm ±15ppm ±20ppm ±30ppm ±50ppm ±100ppm
7	负载电容	Load Capacitance	6pF 8pF 10pF 12.5pF 16pF 20pF 30pF 50pF
8	谐振电阻	Equivalent Series Resis	35K Ω
9	静电容	Shunt Capacitance	1.8pF max
10	激励电平	Drive Level	1 μW standard
11	绝缘电阻	Insulation Resistance	500M Ω at DC100V
12	年老化率	Aging Rate a Year	±5ppm/year (Max)
13	检测仪器	Test Impedance Meter	S&A250B
14	印字形式	Marking	
15	存储温度	Storage Temperature Range	-40°C ~ +85°C
16	存储湿度	Storage Humidity Range	0~95% RH

DIMENSIONS 外形尺寸

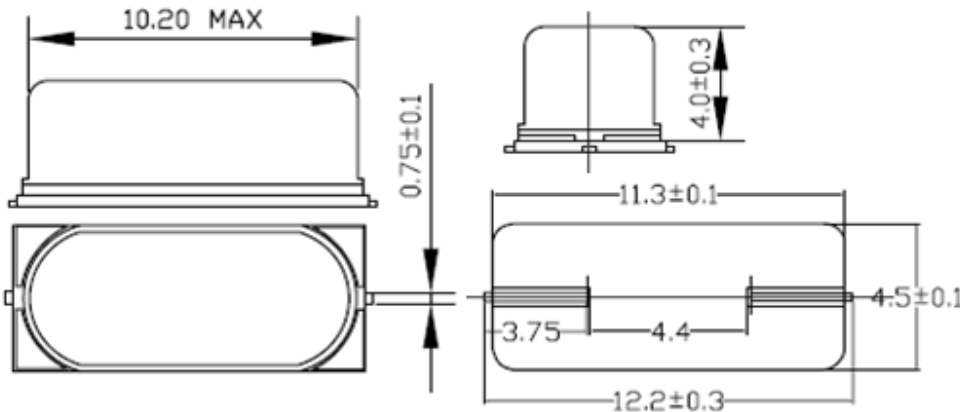



RACTRON
ELECTRONICS

深圳市瑞科创电子有限公司

地址：广东深圳市福田区上步南路1001号锦峰大厦A座3楼308-312室
电话：0755-83062006 82767281 82767282 82767283 32971587
传真：0755-83004913 www.ractron.com bojillsheng@ractron.com.cn

机械及环境性能 Physical and Environment Characteristics

序号	类别	规范	检验标准
1	自由跌落	从60cm高度自由跌落到30mm厚硬木板上，跌落三次	$\Delta f/f \leq \pm 5\text{ppm}$ $\Delta R \leq 20\%$
2	振动	频率10~55Hz，振幅1.5mm，X、Y、Z方向各振动2小时。	$\Delta f/f \leq \pm 5\text{ppm}$ $\Delta R \leq 20\%$
3	引出端强度	a. 拉力：固定振荡器主体，沿引脚轴向施加0.9Kg拉力，保持30±5秒。 b. 弯曲：引脚端头悬挂450g的重物，弯曲90°，时间2~3秒，以相同速度返回原位置，再反向操作一次。	引脚无拔出或断裂现象 $\Delta f/f \leq \pm 5\text{ppm}$ $\Delta R \leq 20\%$
4	密封性	将谐振器浸在酒精中，加压5Kg/cm ² ，时间五分钟。	测量引脚与基座间绝缘电阻>500MΩ (DC100V)
5	可焊性	从引脚末端至底部2~2.5mm放入235℃±5℃的焊槽内，时间2±0.5秒。	沾锡面>90%，频率变化≤±10ppm
6	耐焊接热	从引脚末端至底部2~2.5mm处放入260℃±10℃的焊槽内，时间10±0.5秒	$\Delta f/f \leq \pm 5\text{ppm}$ $\Delta R \leq 20\%$
7	温度循环	将谐振器放置在高低温箱中，将温度设置在-20℃，温度到达后保持30分钟，再将温箱升温到+80℃，保持30分钟，这是一个循环；再将温箱降温到-20℃，开始下一个循环，如此循环三次	$\Delta f/f \leq \pm 5\text{ppm}$ $\Delta R \leq 20\%$
8	恒定湿热	在40±3℃，90~95% RH，放置96小时，取出后恢复2小时	$\Delta f/f \leq \pm 5\text{ppm}$ $\Delta R \leq 20\%$
9	高温老化	85℃±2℃老化96小时，取出后常温下恢复2小时	$\Delta f/f \leq \pm 5\text{ppm}$ $\Delta R \leq 20\%$
10	耐低温	-40℃±2℃放置96小时，取出后常温下恢复2小时	$\Delta f/f \leq \pm 5\text{ppm}$ $\Delta R \leq 20\%$



RACTRON
ELECTRONICS

深圳市瑞科创电子有限公司

地址：广东深圳市福田区上步南路1001号锦峰大厦A座3楼308-312室

电话：0755-83062006 82767281 82767282 82767283 32971587

传真：0755-83004913 www.ractron.com bojillsheng@ractron.com.cn

Physical and Environment Characteristics

Item	Condition of test	Performance Requirements
Mechanical Shock	Resonator shall be measured after 3 times random dropping from the height of 60cm onto hard wooden board of thickness more than 30mm	No visible damage, and measured Values shall meet Table 1
Vibration	Subject resonator to following vibration: Frequency: 10~55Hz Amplitude: 1.5mm Duration: 3 mutually perpendicular planes in each 2 hours Direction: X Y and Z axis	No visible damage, and measured Values shall meet Table 1
Terminal Strength Terminal Pulling Terminal Bending	Force of 5N is applied to each lead in axial direction for 30±5 sec. When force of 5N is applied to each lead in axial direction, the lead shall folded up 90° from the axial direction and folded back to the axial direction. The speed of folding shall be each 3 seconds.	No visible damage, and measured Values shall meet Table 1
Solder ability	Lead terminals are immersed up to 2mm from Resonator's body in soldering bath of 235±5℃ for 2±0.5 sec.	More than 95% of the terminal surface of the resonator shall be covered with fresh solder
Resistance to Soldering Heat	Lead terminals are immersed up to 2mm from Resonator's body in soldering bath of 260±10℃ for 10±0.5 seconds and then resonator shall be measured after being placed in natural conditions for 2 hours.	No visible damage, and measured Values shall meet Table 1
Temperature Cycling	Subject the resonator to -20℃ for 30 min, followed by a high temperature of +80℃ for 30 min. Cycling shall be repeated 5 times. resonator shall be measured after being placed in natural conditions for 2 hours.	No visible damage, and measured Values shall meet Table 1
Heat Resistance	Subject the resonator to +85℃±5℃ for 96 hours, resonator shall be measured after being placed in natural conditions for 2 hours.	No visible damage, and measured Values shall meet Table 1
Cold Resistance	Subject the resonator to -40℃±5℃ for 96 hours, resonator shall be measured after being placed in natural conditions for 2 hours.	No visible damage, and measured Values shall meet Table 1
Humidity	Subject the resonator at +40℃±5℃ and 90%~95% R.H. for 96 hours, resonator shall be measured after being placed in natural conditions for 2 hours.	No visible damage, and measured Values shall meet Table 1



RACTRON
ELECTRONICS

深圳市瑞科创电子有限公司

地址：广东深圳市福田区上步南路1001号锦峰大厦A座3楼308-312室
电话：0755-83062006 82767281 82767282 82767283 32971587
传真：0755-83004913 www.ractron.com bojillsheng@ractron.com.cn

无铅陶瓷贴片产品回流焊温度曲线

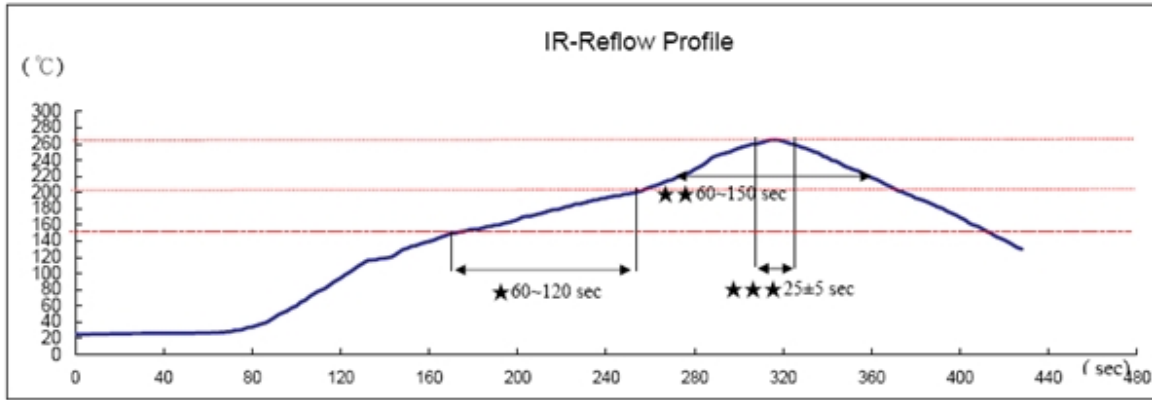

Reference Standard: JEDEC-STD 020

Test conditions: ★Pre-heating : 150°C to 200°C, 60~120secs.
★★Heating : 217°C, 60~150sec.
★★★Peak temperature : 260±5°C, 25±5sec.

10MHz 20MHz 电性能测试数据

THE TESTING DATA OF ELECTRICAL CHARACTERISTICS

TEST DATE:01/16/2012

PART NO. :

FREQUENCY:10.000MHZ

ORDER NO. :

NO	FREQUENCY @ 25 °C (HZ)	OFFSET 0.45 -0.45 (PPM)	ICC 2 (mA)	PULL_H 12 (PPM)	PULL_L -4 -12 (PPM)	FREQ_V_H 0.2 (V)	FREQ_V_L 0.2 -0.2 (V)	START_T 2 (mS)	LINE 10 %	P_P 0.8 (V)
1	10000000.40	0.04	1.10	6.73	-6.44	0.01	-0.01	0.16	0.79	1.25
2	10000000.00	0.00	1.00	6.15	-5.89	0.01	0.00	0.14	0.70	1.24
3	10000000.20	0.02	1.15	6.40	-6.13	0.02	0.00	0.14	0.72	1.24
4	10000000.60	0.06	1.10	6.40	-6.09	0.01	0.00	0.14	0.77	1.24
5	9999999.80	-0.02	1.10	6.51	-6.21	0.01	0.00	0.19	0.84	1.24
6	10000000.60	0.06	1.15	6.73	-6.35	0.02	0.00	0.19	0.83	1.26
7	10000000.60	0.06	1.05	6.42	-6.05	0.02	0.01	0.13	0.82	1.25
8	10000000.50	0.05	1.10	6.21	-5.94	0.02	0.00	0.18	0.71	1.23
9	10000000.20	0.02	1.10	6.89	-6.53	0.01	0.00	0.22	0.84	1.25
10	10000001.10	0.11	1.10	6.73	-6.38	0.01	0.00	0.15	0.81	1.24
	OK_QTY	AVG:	0.04	1.10	6.52	-6.20	0.01	0.16	0.78	1.24
	10.00	STD:	0.04	0.04	0.25	0.22	0.01	0.03	0.06	0.01
		GA:	8.89	****	-37.08	44.98	7.00	****	****	****
		CP:	4.05	6.86	5.44	6.14	13.33	20.40	55.86	18.50
		CPK:	3.69	6.86	3.42	3.38	13.33	20.40	55.86	18.50

INSPECTOR: KELLA
SUPERVISOR: MILLER



RACTRON
ELECTRONICS

深圳市瑞科创电子有限公司

地址：广东深圳市福田区上步南路1001号锦峰大厦A座3楼308-312室
电话：0755-83062006 82767281 82767282 82767283 32971587
传真：0755-83004913 www.ractron.com bojillsheng@ractron.com.cn

THE TESTING DATA OF ELECTRICAL CHARACTERISTICS

TEST DATE:01/26/2013

PART NO. :

FREQUENCY:20.000MHZ

ORDER NO. :

NO	FREQUENCY @ 25 °C (MHZ)	OFFSET 0.45 -0.45 (PPM)	ICC 2 (mA)	V Ver 0.2 -0.2 (PPM)	START_T 2 (mS)	PULL_H 999 5 (PPM)	PULL_L -5 (PPM)	VP_P 1 (V)	VC L 10 0		
1	20	0	1.7	-0.001	0	0.001	6.5	-6.5	1.22	0.7	OK
2	20	-0.02	1.7	-0.001	-0.004	0.001	6.3	-6.5	1.24	0.5	OK
3	20	0.01	1.8	0.002	-0.002	0.003	6.5	-6.5	1.22	0.5	OK
4	20	0.01	1.8	0.001	-0.002	0.001	6.3	-6.5	1.22	0.4	OK
5	20	0.01	1.7	0.002	0.001	0.02	6.5	-6.7	1.24	0.6	OK
6	20.000001	0.03	1.8	0.002	0.003	0.02	6.9	-6.9	1.25	0.6	OK
7	19.999999	-0.04	1.8	0.002	0	0.002	6.5	-7	1.24	0.4	OK
8	20.000001	0.05	1.8	0.002	0.003	0.02	6.9	-7	1.22	0.5	OK
9	19.999999	-0.03	1.7	0.001	-0.001	0.002	6.8	-7.1	1.22	0.4	OK
10	20	0	1.7	0.002	0.003	0.02	6.4	-6.7	1.24	0.6	OK
11	20.000001	0.04	1.8	0.001	0.001	0.001	6.7	-6.9	1.22	0.5	OK
12	19.999999	-0.04	1.7	0	0.002	0.02	6.5	-6.5	1.22	0.7	OK
13	19.999999	-0.03	1.7	0.003	0.003	0.002	6.8	-7	1.22	0.5	OK
14	19.999999	-0.05	1.8	0.003	0.005	0.001	6.9	-6.9	1.24	0.5	OK
15	19.999999	-0.05	1.7	0.005	0.001	0.001	6.5	-7	1.22	0.5	OK
16	20	0.02	1.7	0.002	0.02	0.02	6.5	-7	1.22	0.6	OK
17	20.000001	0.04	1.8	0.003	0.001	0.001	6.8	-6.8	1.22	0.4	OK
18	20	0.02	1.7	0.006	0.002	0.002	6.5	-7	1.22	0.5	OK
19	20	0.02	1.8	0.004	0.007	0.002	6.7	-6.5	1.22	0.5	OK
20	19.999999	-0.07	1.8	0.004	0.004	0.02	6.5	-6.6	1.22	0.6	OK
	AVG:	0.0	1.7	0.0	0.0	0.0	6.6	-6.8	1.2	0.5	
	STD:	0.0	0.0	0.0	****	0.0	0.2	0.2	0.0	0.1	
	GA:	-1.0									
	CP:	4.4									
	CPK:	4.4									
		116									
		116									

TEST_QTY: 20

OK_QTY: 20

NG_QTY: 0

INSPECTOR: KELLA

SUPERVISOR: MILLER



RACTRON
ELECTRONICS

深圳市瑞科创电子有限公司

地址：广东深圳市福田区上步南路1001号锦峰大厦A座3楼308-312室
电话：0755-83062006 82767281 82767282 82767283 32971587
传真：0755-83004913 www.ractron.com bojillsheng@ractron.com.cn

10MHz 20MHz 温度稳定性测试数据

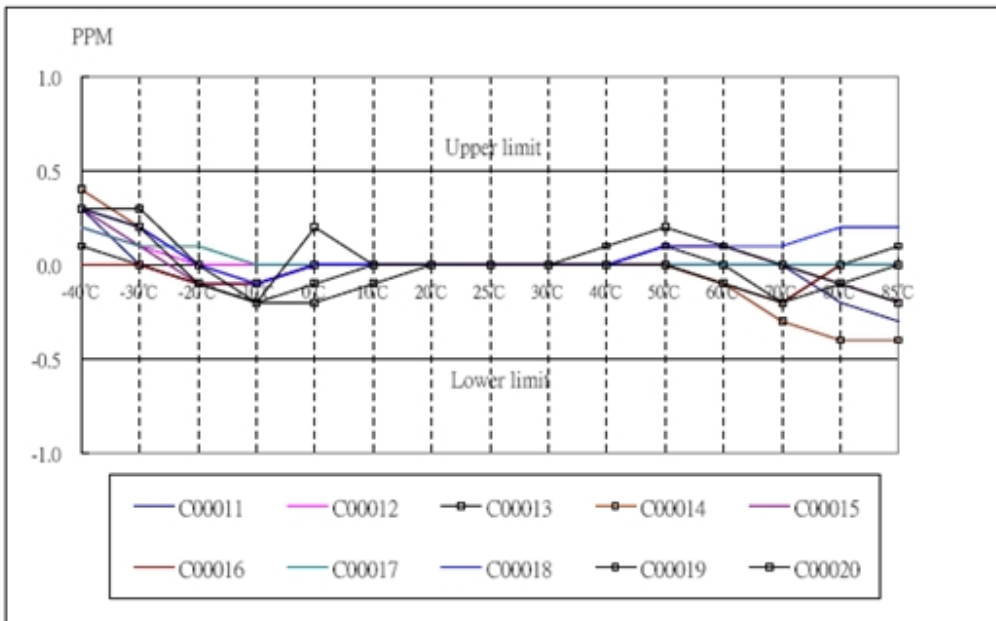
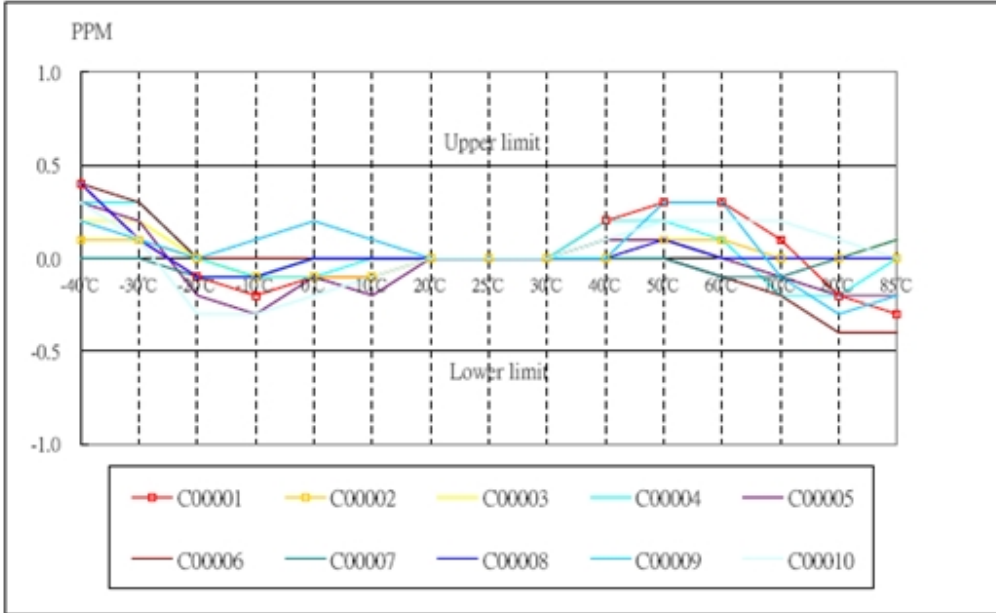

10MHz 20MHz 相位噪声测试数据



RACTRON
ELECTRONICS

深圳市瑞科创电子有限公司

地址：广东深圳市福田区上步南路1001号锦峰大厦A座3楼308-312室
电话：0755-83062006 82767281 82767282 82767283 32971587
传真：0755-83004913 www.ractron.com bojillsheng@ractron.com.cn

$\mathcal{L}(f)$ Phase Noise at 10.0 MHz (dBc/Hz)

10 dB/Div

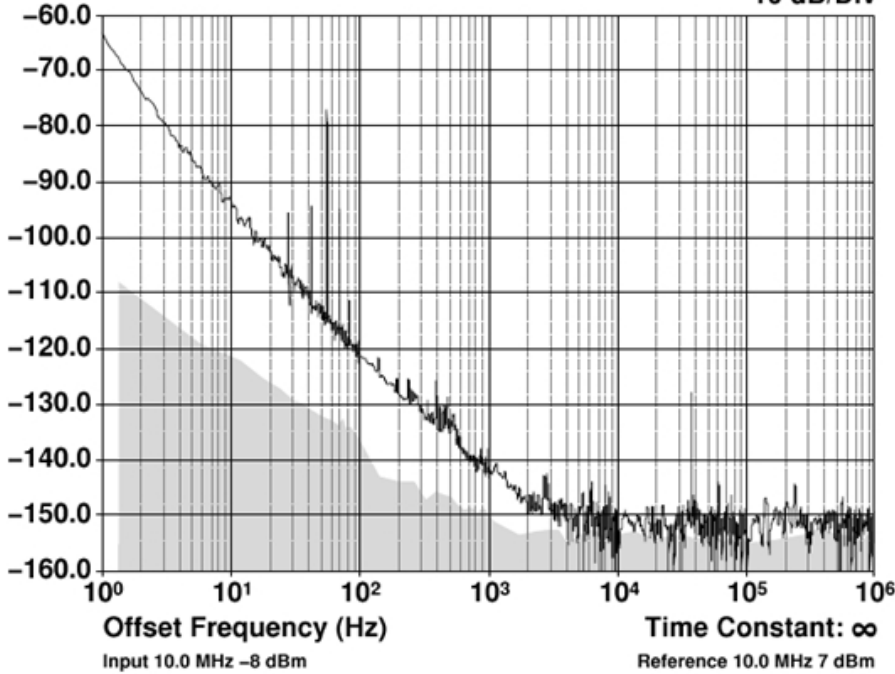

$\mathcal{L}(f)$ Phase Noise at 20.0 MHz (dBc/Hz)

10 dB/Div

