



实验室电源供应器系列 Laboratory Power Supply Series

PSI 8000 2U

640W - 3000W

32V - 720V

4A - 120A



此图为标准 2U 产品 / Picture shows standard 2U version

PSI 8080-40 2U:	09 230 410	PSI 8720-15 2U:	09 230 416
PSI 8080-60 2U:	09 230 411	PSI 8032-20 2U:	09 230 417
PSI 8080-120 2U:	09 230 412	PSI 8065-10 2U:	09 230 418
PSI 8160-60 2U:	09 230 413	PSI 8160-04 2U:	09 230 419
PSI 8360-15 2U:	09 230 414	PSI 8040-60 2U:	09 230 425
PSI 8360-30 2U:	09 230 415	PSI 8040-120 2U:	09 230 426



© Elektro-Automatik

严禁再版、复印或部分错误地使用该说明书，否则将承担该行为导致的法律后果。

安全说明



危险电压

警戒：输出电压可能会升高至危险电位 (> 60 VDC) ！

所有带电元件必须屏蔽起来。输出端的所有操作必须在产品断开主电源（电源开关关闭）后才能执行，可能只有受过电流危险知识的人士方可操作。负载和产品（输出端）间的任何连接必需防止相互碰擦。连接到电源输出端的应用设备必须配置好，并配有保险丝，以防止使用时由于过载或误操作而损坏产品。



重点！记住！

- 请仅在铭板标示电压下操作该仪器。
- 请勿将任何机械零件，特别是金属件，插入仪器通风孔内，否则会有触电的危险，也可能损坏产品
- 请避免在本产品周围使用任何液体物质，以免进入产品内并损坏产品
- 从电源插座上拔下电源线后，请勿立即触摸电源线插头的金属接触片，因为可能有触电的危险
- 不要将负载，特别是阻性负载，在电源输出打开后才连接到产品上，因为可能会产生火花，从而损坏产品或伤到人的手。
- 从后板插槽安装接口卡时，请遵循一般防静电规则
- 只能在产品完全关闭(电源开关为关闭状态)后插入和取出接口卡
- 产品老化以及超负荷使用，可能引起按钮和旋钮类控制件出现不可预测的行为。

	页码
1. 简介	6
2. 技术规格	6
2.1 控制面板	6
2.2 各型号详细规格	7
3. 产品描述	9
3.1 各面视图	9
3.2 供应清单	10
4. 一般信息	11
4.1 序言/ 安全警戒	11
4.2 制冷	11
4.3 拆开产品	11
5. 安装	11
5.1 目检	11
5.2 2U型号的市电连接	11
5.3 4U型号的市电连接	11
5.4 直流输出端	11
5.5 “感测”端 (远程感测)	11
5.6 接口卡插槽	11
6. 操作	12
6.1 显示器	12
6.2 使用的符号	12
6.3 各显示元素简介	12
6.4 打开电源	13
6.5 打开功率输出	13
6.6 调节设定值	13
6.7 转换按钮面板	14
6.8 锁定控制面板	14
6.9 更改位置模式	14
6.10 转至函数管理器	14
6.11 激活菜单	14
6.12 参数页	15
6.13 报警、警戒和信号提示	15
6.14 报警和警戒的确认	15
6.15 函数管理器	15
6.15.1 配置函数	16
6.15.2 函数布局	16
6.15.3 配置序列	17
6.15.4 与序列有关的参数	17
6.15.5 定义序列点	17
6.15.6 函数运行时的显示	17
6.15.7 函数管理器的控制	18
7. 产品设置	19
7.1 定义操作参数	20
7.2 预定义预设清单	20
7.3 调节极限	21
7.4 配置控制面板	21
7.5 配置图行显示器	22
7.6 监控	22
7.6.1 电压监控	22
7.6.2 电流监控	23
7.6.3 阶跃响应监控	24
7.7 恢复至默认配置	25
7.8 解锁U/I/R运行模式	25
7.9 锁定产品配置	25
8. 数字接口卡	25
8.1 一般信息	25
8.2 配置接口卡	25

	页码
9. 内置模拟接口	26
9.1 一般信息	26
9.2 模拟接口的设定	26
9.3 D-Sub插座总图	26
9.4 应用举例	26
9.5 各引脚分布说明	27
10. 其它应用	28
10.1 远程感测	28
10.2 连接不同类型的负载	28
10.3 市电出现欠压或过压	28
10.4 系统总线端的功能	29
10.4.1 主机-辅机模式下的串联	29
10.4.2 共享总线模式下的并联	30
10.4.3 混合连接	30
10.5 连网	31
10.6 其它附件和选项功能	31
10.7 固件更新	31

1. 简介

PSI 8000 2U系列因其19“拉拔式结构外形，极其适用于测试系统和工业控制设备。

除电源产品的标准功能外，用户还可定义和恢复不同的预设值，用可定义极限监控设定值和实际值，用函数管理器创建和配置预设值的函数循环。

它还有一个特点，即配有内置模拟接口，可在0...5V或0...10V普通电压范围内工作。从而提供一简易监控本产品或完全远程控制的方法。可修改数字输入脚和输出脚的逻辑电位。1kW以上型号可进行输出功率调节。

还可选择多款数字接口卡，通过电脑实现更宽光谱范围的控制和监控功能，或者另外一外部扩展卡-IF-A1，通过外部手段，如PLC-可编程控制器当内部接口，对产品进行控制。

通过接口卡的使用可轻易地将产品整合于现有系统内，且根本不需配置接口卡或仅需配置少数设定值。

本产品通过接口卡可连接其他类型电源，并借此控制它们。或者通过外置控制系统，如PLC-可编程控制器，对本产品进行控制和监测。

1000W以上的多数型号还有这些特征：带可调功率调整电路（除两个型号外，详见技术规格表），以及实现主-从模式下的串联或共享总线下的并联的“System Bus”端子。

主功能一览：

- 设定0...100%范围内的电压和电流
- 0...110% U_{Nom} 可调过压阈值
- 插拔式接口卡（CAN, USB, RS232, IEEE/GPIB, 模拟, Ethernet/LAN, Profibus）
- 外部控制和监测用模拟接口，用0...5V或0...10V（可选）控制0...100%的范围值
- 功率级别：640W, 1000W, 1500和3000W
- 温控风扇
- 状态（OT, OVP, CC, CV）指示灯
- 4种可选内存集，监控函数
- 函数管理器
- 可调内阻（选项）
- 高速跃变（选项）
- 带汽车点火序列的内置有源负载（选项）
- 主-从串联连接（1kW型号起）
- 并联连接（共享总线下）

2. 技术规格

2.1 控制面板

型号

显示器：128x64点阵图形显示器
操作控制件：6个旋钮，2个按钮

显示格式

额定值限定最大可调范围。

电压、电流和功率（1kW型号以上）实际值与设定值同时显示，过压阈值设定值则分开显示。

电压的显示

分辨率：4位数
格式：0.00V...99.99V
100.0...999.9V

电流的显示

分辨率：4位数
格式：0.000A...9.999A
0.00A...99.99A

功率的显示

分辨率：4位数
格式：0.0W...999.9W
0.000kW...9.999kW

阻值的显示

（仅在“内阻控制”选项功能解锁情况下）
分辨率：4位数
格式：00.00m Ω ...99.99m Ω
0.000 Ω ...9.999 Ω
00.00 Ω ...99.99 Ω

时间的显示

时间以4种自动转换的范围显示。

分辨率：
范围1：2ms to 9.999 s
范围2：10ms to 59.99s
范围3：1:00m to 59:59min
范围4：1:00h to 99:59h

精确度：

范围1：2ms
范围2：10ms
范围3：1s
范围4：1 min

2.2 各型号详细规格

	PSI 8032-20 2U	PSI 8065-10 2U	PSI 8160-04 2U	PSI 8080-40 2U	PSI 8040-60 2U	PSI 8080-60 2U
电源输入						
输入电压	90...264V	90...264V	90...264V	90...264V	90...264V	90...264V
输入电压功率降额	-	-	-	-	90...150V	90...150V
230V时输入电流	max. 3.2A	max. 3.4A	max. 3.2A	max. 4.8A	max. 7.5A	max. 7.5A
输入频率	45...65Hz	45...65Hz	45...65Hz	45...65Hz	45...65Hz	45...65Hz
输入保险丝	T 8A	T 8A	T 8A	T 16A	T 16A	T 16A
功率因素值	> 0.99	> 0.99	> 0.99	> 0.99	> 0.99	> 0.99
输出 - 电压						
额定电压 U_{Nom}	32V	65V	160V	80V	40V	80V
可调范围	0V... U_{Nom}	0V... U_{Nom}	0V... U_{Nom}	0V... U_{Nom}	0V... U_{Nom}	0V... U_{Nom}
市电波动范围在±10% ΔU_{IN} 时的稳定度	< 0.02%	< 0.02%	< 0.02%	< 0.02%	< 0.02%	< 0.02%
带载10...90%时的稳定度	< 0.05%	< 0.05%	< 0.05%	< 0.05%	< 0.05%	< 0.05%
纹波 P-P	< 100mV	< 150mV	< 120mV	< 10mV	< 10mV	< 10mV
纹波 RMS	< 8mV	< 10mV	< 20mV	< 4mV	< 4mV	< 4mV
精确度*	≤ 0.2%	≤ 0.2%	≤ 0.2%	≤ 0.2%	≤ 0.2%	≤ 0.2%
显示器分辨率	10mV	10mV	100mV	10mV	10mV	10mV
远程感测补偿	max. 2.0V	max. 2.0V	max. 2.0V	max. 2.0V	max. 2.0V	max. 2.0V
过压保护门限 (可调)	0...35.2V	0...71.5V	0...176V	0...88V	0...44V	0...88V
输出 - 电流						
额定电流 I_{Nom}	20A	10A	4A	40A	60A	60A
可调范围	0... I_{Nom}	0... I_{Nom}	0... I_{Nom}	0... I_{Nom}	0... I_{Nom}	0... I_{Nom}
市电波动范围在±10% ΔU_{IN} 时的稳定度	< 0.05%	< 0.05%	< 0.05%	< 0.05%	< 0.05%	< 0.05%
带载0...100% ΔU_{OUT} 时的稳定度	< 0.15%	< 0.15%	< 0.15%	< 0.15%	< 0.15%	< 0.15%
纹波 P-P	< 65mA	< 25mA	< 3mA	< 19mA	< 100mA	< 100mA
纹波 RMS	< 10mA	< 3mA	< 1mA	< 7mA	< 7mA	< 7mA
精确度*	≤ 0.2%	≤ 0.2%	≤ 0.2%	≤ 0.2%	≤ 0.2%	≤ 0.2%
显示器分辨率	10mA	10mA	1mA	10mA	10mA	10mA
负载从10...90%瞬态恢复时间	< 2ms	< 2ms	< 2ms	< 2ms	< 2ms	< 2ms
输出 - 功率						
额定功率 P_{Nom}	640W	650W	640W	1000W	1500W	1500W
降低额定功率	-	-	-	-	1000W	1000W
精确度*	-	-	-	0... P_{Nom}	0... P_{Nom}	0... P_{Nom}
可调范围	-	-	-	≤ 0.2%	≤ 0.2%	≤ 0.2%
调节分辨率	0.1W	0.1W	0.1W	1W	1W	1W
其它						
调节分辨率	90.5%	93.0%	93.0%	90.5%	90.5%	90.5%
环境温度	0...40° C	0...40° C	0...40° C	0...40° C	0...40° C	0...40° C
储存温度	-20...70° C	-20...70° C	-20...70° C	-20...70° C	-20...70° C	-20...70° C
相对湿度	< 80%	< 80%	< 80%	< 80%	< 80%	< 80%
标准型号的产品尺寸 (WxHxD)	19" 2U 380mm	19" 2U 380mm	19" 2U 380mm	19" 2U 460mm	19" 2U 460mm	19" 2U 460mm
带ZH选项功能的产品尺寸 (WxHxD)	19" 2U 380mm	19" 2U 380mm	19" 2U 380mm	19" 2U 460mm	19" 2U 460mm	19" 2U 460mm
标准型号的产品重量	9.5kg	9.5kg	9.5kg	13.5kg	13.5kg	13.5kg
带ZH选项功能的产品重量	11kg	11kg	11kg	15kg	15kg	15kg
绝缘耐压输出对外壳	500V DC	500V DC	500V DC	500V DC	500V DC	500V DC
绝缘耐压输入对输出	4200V DC					
制冷	风扇制冷, 前板为入风口, 后板为排风口					
安全标准	EN 60950					
EMC标准	EN 61326, EN 55022 等级 B					
过压等级	2					
保护等级	1					
污染程度	2					
工作高度	<2000m					
串联操作						
最大串联电压	600V					
主-从操作	无					
并联操作						
最大并联电压	1500V					
主-从操作	有, 经共享总线连接器					
模拟编程						
输入范围	0...5V 或 0...10V, 可选					
精确度*	≤ 0.2%					
输入阻抗	53kOhm					
产品编号	09230417	09230418	09230419	09230410	09230425	09230411

* 与额定值有关, 该精确度决定设定值与实际值间允许最大误差。

举例: 一台80V型号产品的电压精确度最少为0.2%, 即为160mV。当设定5V电压时, 且允许最大误差为160mV, 故得出实际值可能在4.84V和5.16V之间。

	PSI 8360-15 2U	PSI 8040-120 2U	PSI 8080-120 2U	PSI 8160-60 2U	PSI 8360-30 2U	PSI 8720-15 2U
电源输入						
输入电压	90...264V	180...264V	180...264V	180...264V	180...264V	180...264V
输入电压功率降额	90...150V	180...207V	180...207V	180...207V	180...207V	180...207V
230V时输入电流	max. 7.5A	max. 15A	max. 15A	max. 15A	max. 15A	max. 15A
输入频率	45...65Hz	45...65Hz	45...65Hz	45...65Hz	45...65Hz	45...65Hz
输入保险丝 (标准型号)	T 16A	T 16A	T 16A	T 16A	T 16A	T 16A
输入保险丝 (带ZH选项功能的型号)	T 16A	2x T16A	2x T16A	2x T16A	2x T16A	-
功率因素值	> 0.99	> 0.99	> 0.99	> 0.99	> 0.99	> 0.99
输出 - 电压						
额定电压 U_{Nom}	360V	40V	80V	160V	360V	720V
可调范围	0V... U_{Nom}	0V... U_{Nom}	0V... U_{Nom}	0V... U_{Nom}	0V... U_{Nom}	0V... U_{Nom}
市电波动范围在 $\pm 10\% \Delta U_{IN}$ 时的稳定度	< 0.02%	< 0.02%	< 0.02%	< 0.02%	< 0.02%	< 0.02%
带载10...90%时的稳定度	< 0.05%	< 0.05%	< 0.05%	< 0.05%	< 0.05%	< 0.05%
纹波 P-P	< 50mV	< 10mV	< 10mV	< 20mV	< 30mV	< 50mV
纹波 RMS	< 8mV	< 5mV	< 5mV	< 10mV	< 12mV	< 20mV
精确度*	$\leq 0.2\%$	$\leq 0.2\%$	$\leq 0.2\%$	$\leq 0.2\%$	$\leq 0.2\%$	$\leq 0.2\%$
显示器分辨率	100mV	100mV	100mV	100mV	100mV	100mV
远程感测补偿	max. 2.0V	max. 2.0V	max. 2.0V	max. 2.0V	max. 2.0V	max. 2.0V
过压保护门限 (可调)	0...396V	0...44V	0...88V	0...176V	0...396V	0...792V
输出 - 电流						
额定电流 I_{Nom}	15A	120A	120A	60A	30A	15A
可调范围	0... I_{Nom}	0... I_{Nom}	0... I_{Nom}	0... I_{Nom}	0... I_{Nom}	0... I_{Nom}
市电波动范围在 $\pm 10\% \Delta U_{IN}$ 时的稳定度	< 0.05%	< 0.05%	< 0.05%	< 0.05%	< 0.05%	< 0.05%
带载0...100% ΔU_{OUT} 时的稳定度	< 0.15%	< 0.15%	< 0.15%	< 0.15%	< 0.15%	< 0.15%
纹波 P-P	< 1mA	< 25mA	< 25mA	< 18mA	< 60mA	< 2mA
纹波 RMS	< 0.45mA	< 9mA	< 9mA	< 6mA	< 21mA	< 1mA
精确度*	$\leq 0.2\%$	$\leq 0.2\%$	$\leq 0.2\%$	$\leq 0.2\%$	$\leq 0.2\%$	$\leq 0.2\%$
显示器分辨率	10mA	100mA	100mA	10mA	10mA	10mA
负载从10...90%瞬态恢复时间	< 2ms	< 2ms	< 2ms	< 2ms	< 2ms	< 2ms
输出 - 功率						
额定功率 P_{Nom}	1500W	3000W	3000W	3000W	3000W	3000W
降低额定功率	1000W	2500W	2500W	2500W	2500W	2500W
精确度*	0... P_{Nom}	0... P_{Nom}	0... P_{Nom}	0... P_{Nom}	0... P_{Nom}	0... P_{Nom}
可调范围	$\leq 0.2\%$	$\leq 0.2\%$	$\leq 0.2\%$	$\leq 0.2\%$	$\leq 0.2\%$	$\leq 0.2\%$
调节分辨率	1W	1W	1W	1W	1W	1W
其它						
调节分辨率	93.0%	90.5%	90.5%	93.0%	90.5%	90.5%
环境温度	0...40°C	0...40°C	0...40°C	0...40°C	0...40°C	0...40°C
储存温度	-20...70°C	-20...70°C	-20...70°C	-20...70°C	-20...70°C	-20...70°C
相对湿度	< 80%	< 80%	< 80%	< 80%	< 80%	< 80%
标准型号的产品尺寸 (WxHxD)	19" 2U 460mm	19" 2U 460mm	19" 2U 460mm	19" 2U 460mm	19" 2U 460mm	19" 2U 460mm
带ZH选项功能的产品尺寸 (WxHxD)	19" 2U 460mm	19" 4U 460mm	19" 4U 460mm	19" 4U 460mm	19" 4U 460mm	-
标准型号的产品重量	13.5kg	16.5kg	16.5kg	16.5kg	16.5kg	16.5kg
带ZH选项功能的产品重量	15kg	19.5kg	19.5kg	19.5kg	19.5kg	-
绝缘耐压输出对外壳	500V DC	500V DC	500V DC	500V DC	500V DC	1000V DC
绝缘耐压输入对输出	4200V DC					
制冷	风扇制冷, 前板为入风口, 后板为排风口					
安全标准	EN 60950					
EMC标准	EN 61326, EN 55022 等级 B					
过压等级	2					
保护等级	1					
污染程度	2					
工作高度	<2000m					
串联操作						
最大串联电压	600V					
主-从操作	无					
并联操作						
最大并联电压	1500V					
主-从操作	有, 经共享总线连接器					
模拟编程						
输入范围	0...5V 或 0...10V, 可选					
精确度*	$\leq 0.2\%$					
输入阻抗	53kOhm					
产品编号	09230414	09230426	09230412	09230413	09230415	09230416

* 与额定值有关, 该精确度决定设定值与实际值间允许最大误差。

举例: 一台80V型号产品的电压精确度最少为0.2%, 即为160mV。当设定5V电压时, 且允许最大误差为160mV, 故得出实际值可能在4.84V和5.16V之间。

3. 产品描述

3.1 各面视图



图 1. 2U标准型产品前视图，带ZH选项功能的则不同



图 2. 2U产品后视图

注解:

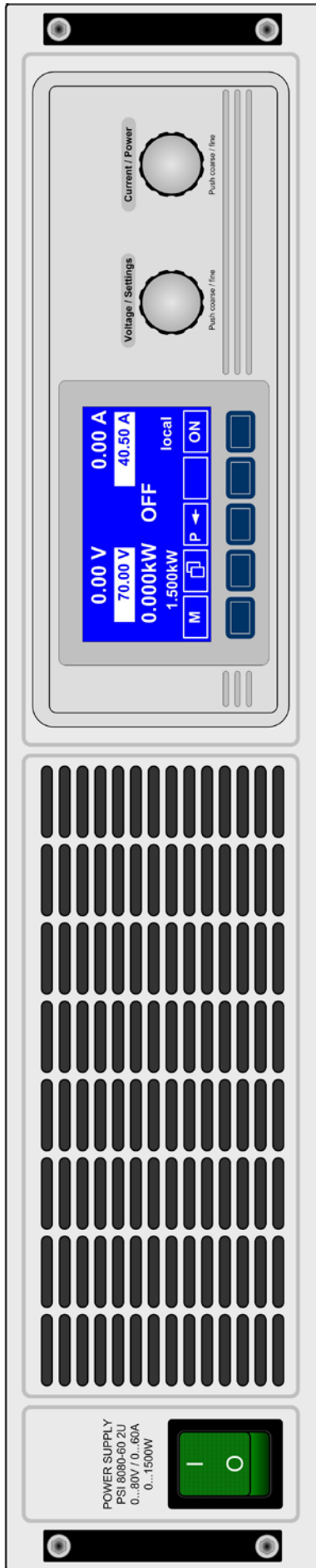
- A - 电源开关
- B - 通风槽
- C - 控制面板
- D - 模拟接口, 15引脚, 母插
- E - 数字扩展卡插槽
- F - 系统总线
- G - 风扇
- H - 电源输出端子, M8螺丝端子块
- J - 输入保险丝 (保险丝值请见,2. 技术规格“)
- K - 电源输入插座 (见章节5.2)
- L - 带ZH选项功能产品的控制面板

系统总线引脚分布 (详情请参考10.4章节) :

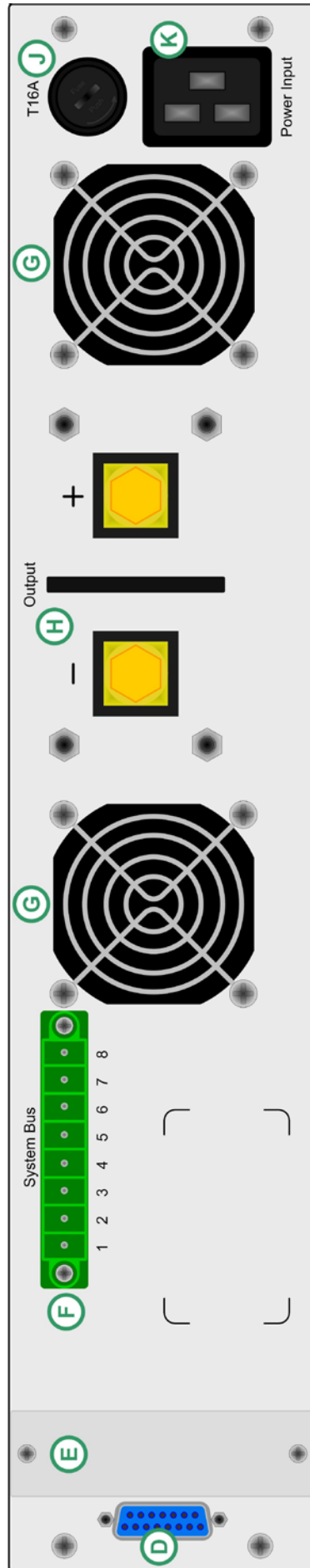
- 1 - 感测 +
- 2 - 感测 -
- 3 - 主机输出电流
- 4 - 主机输出电压
- 5 - 从机输入电流
- 6 - 从机输入电压
- 7 - 共享总线
- 8 - 地



图 3. 带ZH选项功能，高度为4U的产品前视图



图 4. 4U产品型号的后视图

注解:

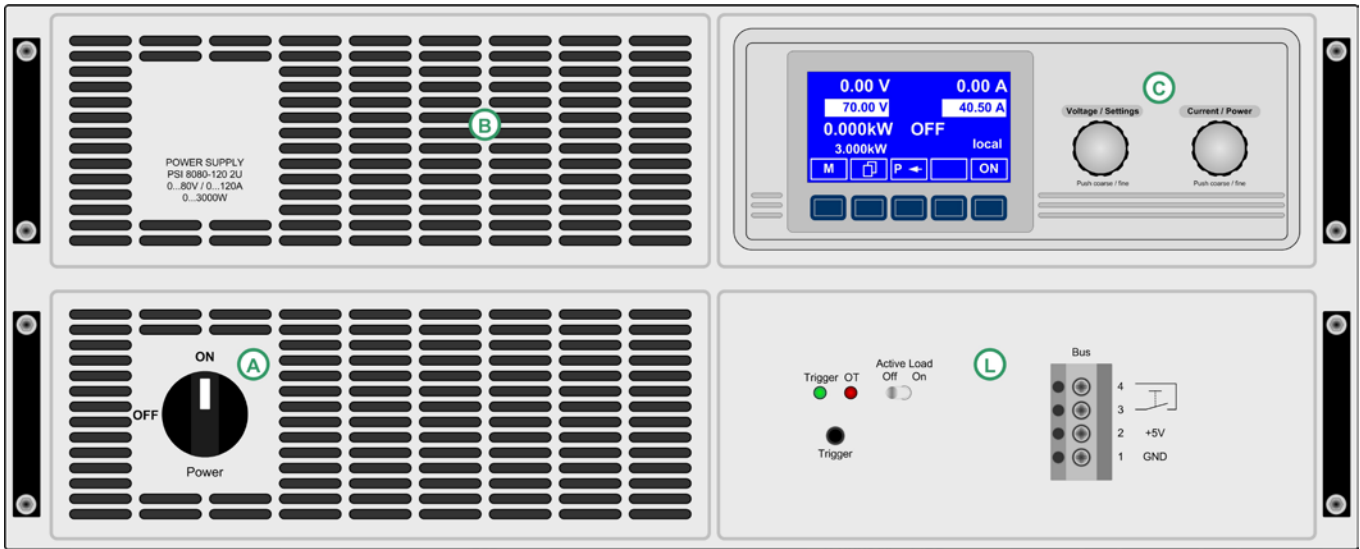
- A- 电源开关
- B - 通风槽
- C - 控制面板
- D - 模拟接口，15引脚，母插
- E - 数字扩展卡插槽
- F- 系统总线
- G - 风扇
- H - 电源输出端子，M8螺丝端子块
- J- 输入保险丝（保险丝值请见“技术规格”）
- K - 电源输入插座（见章节5.2）
- L- 带ZH选项功能产品的控制面板

系统总线引脚分布（详情请参考10.4章节）：

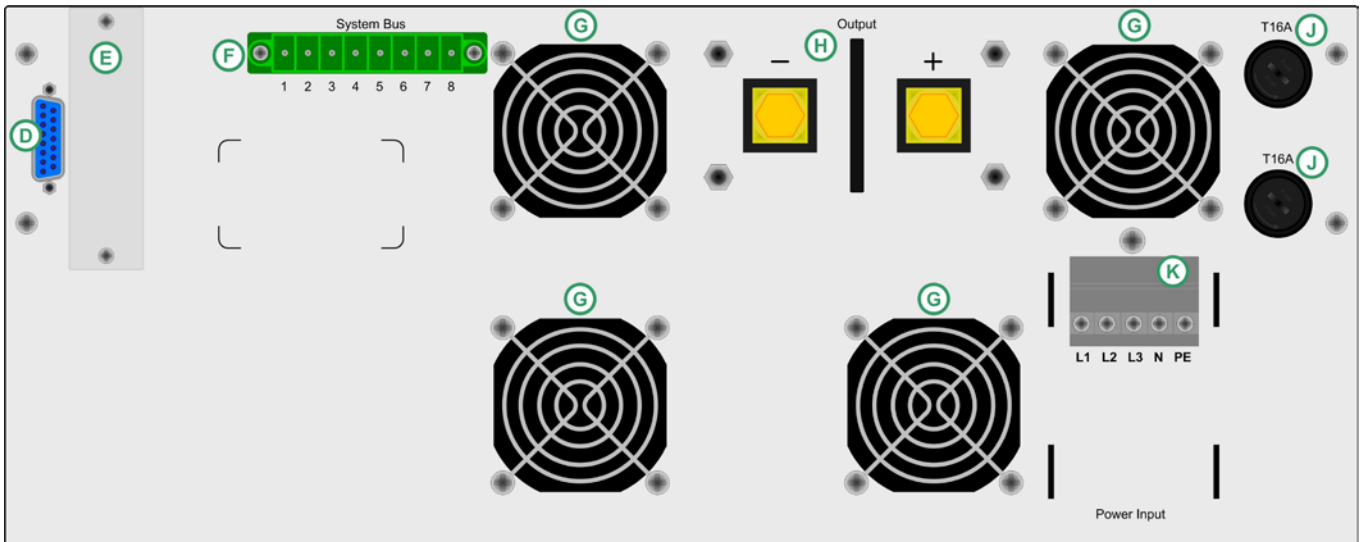
- 1 - 感测 +
- 2 - 感测 -
- 3 - 主机输出电流
- 4 - 主机输出电压
- 5 - 从机输入电流
- 6 - 从机输入电压
- 7 - 共享总线
- 8 - 地

3.2 供应清单

- 1 x 电源供应器
- 1 x 印刷版使用说明书
- 1 x 电源线（仅2U型号产品有）

4. 一般信息

4.1 序言/安全警戒

本说明书和产品专供对电源有基本了解的人士使用。不应给无基本电器知识的人士操作，因本说明书未作此方面描述。操作不当和未遵守安全说明的操作，可能会损坏产品或丧失产品保修权！

4.2 制冷

要保持外壳两侧进风孔和后板排风孔的清洁，以确保良好的冷却效果。注意产品后方至少10cm以内无任何物体阻挡，以保证空气流通顺畅。

4.3 拆开产品

若想拆开产品或用工具从产品内部拆除零件，可能会有高压触电的危险。必须将本产品与主电源断开后方可进行，否则用户自行承担风险。

只有受过电流危险知识训练的人员方可进行相关的维护或修理。

5. 安装

5.1 目检

收到本产品后，请检查是否有外观受损痕迹。如有，请不要操作本产品，应立即联系您的供应商。

5.2 2U型号的市电连接

本产品通过电源线接地。故仅可与带接地触点的电源插座相连。且连线中间不可接无接地触点的延伸线！

还装有5x20mm的保险丝(具体数值请看规格参数表)，装于产品后板的保险座内。

5.3 4U型号的市电连接

尽管4U产品有一三相输入端，但却使用普通的230V供电电压(L+N+PE)。鉴于安全考虑不允许接三相输入电压。而连接L1和L2，加上N和PE。故输入端接线必须如下图所示：

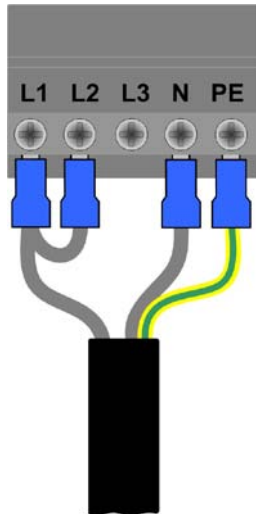

5.4 直流输出端

功率输出端位于产品前部。它有永久短路保护。

本输出端**无保险**！为避免损坏负载设备，应随时注意负载机的额定值。

连接线的直径取决于多个条件，像输出电流、线长和环境温度。

建议使用长为1.5m的连线：

10A 以下：	0.75mm ² ，	15A 以下：	1.5mm ²
30A 以下：	4mm ²	40A 以下：	6mm ²
60A 以下：	16mm ²	120A 以下：	35mm ²

针对**每根线**(弹性线)。

输出“+”和“-”极未接地，若有必要，可将其中一极接地。

注意！将其中一输出极接地时，请随时检查负载(如电子负载)的其中一极是否也已接地。否则将引起短路！

注意！串联时注意输出极的电位转移！此时仅建议带最低电位的极点接地。

5.5 “感测”端(远程感测)

为补偿负载线上(每根线最大1V)的压降，电源可“感测”负载端而不是输出端的电压。它将调整输出电压以使负载获得所需电压。

T按正确极性将远程感测线连到产品后板**System Bus**端。

(+)感测端只能与负载设备(+)端相连，(-)感测端与(-)端相连，否则会损坏两头的产品。

详情也可参考章节“10.1 远程感测”。

5.6 接口卡插槽

可选择给本产品配上接口卡。接口卡插槽位于产品后端。更多信息见章节“8. 数字接口卡”。

6. 操作

6.1 显示器

图5展示了图形显示器的总图。正常操作时，显示器显示实际和设定电压（左上排）和电流（右上排），以及功率（左下排）。而在设置模式下，显示参数和相关设置。

功率设定值仅在1kW型号产品上显示。

如果“内阻控制”解锁，内阻设定值可能代替功率设定值，随产品设置所选而定。

6.2 使用的符号

下列描述的显示和操作元素以不同符号标示。

 = **Displayed only**, 所有只显示，代表状态的元素以这个符号标识

 = **Parameter**, 可更改值以该符号标识，且表示强调

 = **Menu items**, 可选，指向下个分级或带参数的最低级 {...}括号表示可能的选项或参数的调节范围。

6.3 各显示元素简介

 **70.00 V** 实际输出电压

 **35.00 A** 实际输出电流

 **1.300kW** 实际输出功率

正常操作期间，实际值以大写字母显示。

 **70.00 V** 设定电压

期望输出电压（左旋钮）的目标值。可对该值粗调（见章节6.3步宽）或细调（逗号右边的位数）。粗调和细调间的转换通过左旋钮上的按钮完成。

 **40.50 A** 设定电流

期望输出电流（右旋钮）的目标值。可对该值粗调（见章节6.3步宽）或细调（逗号右边的位数）。粗调和细调间的转换通过右旋钮上的按钮完成。要调节设定值必须先按  按钮。

 **1.500kW** 设定功率

期望最大输出功率的目标值（右旋钮）。要设定该值，必须在之前就按下  按钮。

 **10.00 Ω** 设定内阻（选项）

期望内阻的目标值（右旋钮）。如果内阻控制解锁，且在产品设置下选择了U/I/R模式，该设定值替代功率设定值。要设定该值，必须先按下  按钮。





图 5

电源输出的状态显示于显示器右下角。

 **{ON,OFF}** 电源输出状态

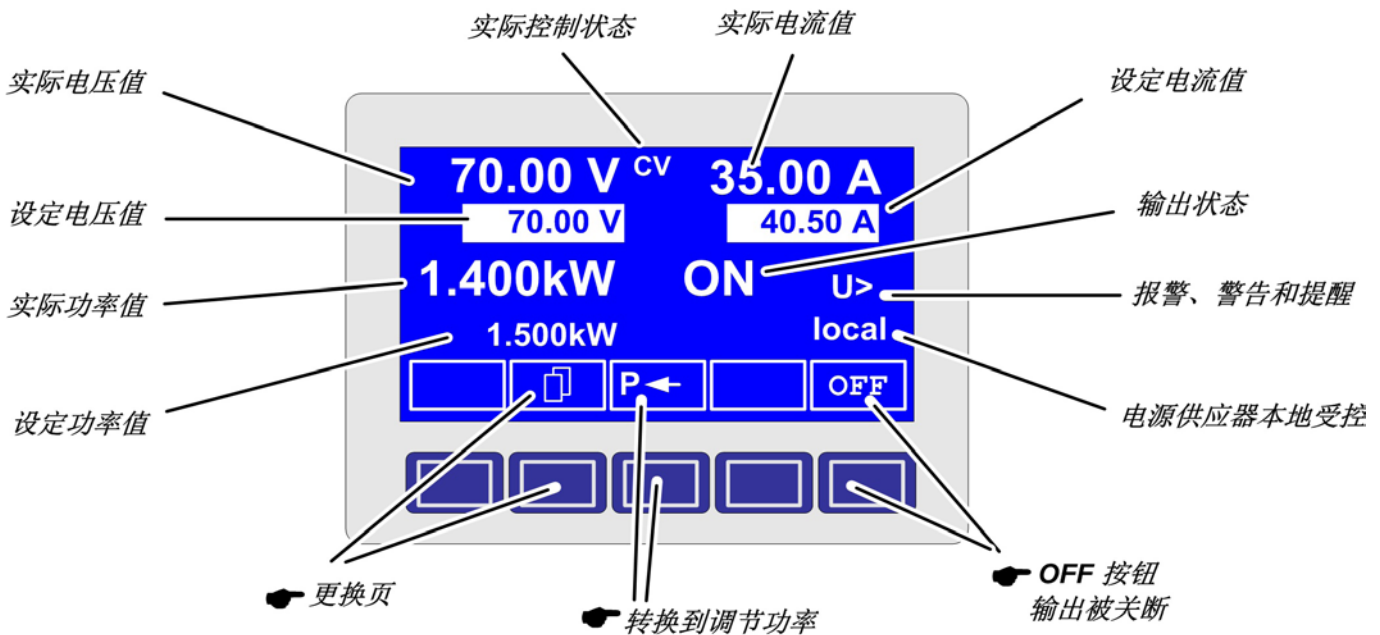
当前激活的控制模式显示于相应实际值的右边。比如，“CV”缩写显示于实际电压的旁边，表示“控制电压”模式正在运行。这些输出值由运行的控制模式限定：

 **CV** - 由电压设定值限定
(= 恒定电压)

 **CP** - 由功率设定值限定
(= 恒定功率)

 **CC** - 由电流设定值限定
(= 恒定电流)

 **CR** - 由设定内阻限定 (在U/I/R模式下)，在实际值旁边
(= 恒定电阻)

另外与输出状态不同的，还有报警、警戒或信号提示：

 **Alarm** 如： **OT** = 过温

 **Warnings** 如： **U>** = 过压

 **Signals** 如： **I>** = 过流

产品当前受控位置显示于输出状态下方。此位置表示用户在未改变位置时绝不可控制该仪器。

 **local** 只能在该仪器上控制

 **remote** 通过通讯接口 (IF-C1, IF-R1, IF-U1 等。) 进行远程控制

 **extern** 通过模拟接口远程控制

6.4 打开电源

电源开关启动仪器。打开后，显示屏上显示产品型号，如果是程控型，再显示用户文本。

通过其中一个数字接口卡，利用LabView VI进入用户文本，该文本可在多组产品同时使用的复杂环境下辨别每个产品。

当识别和进入内部系统后，电源的最后状态(设定值，报警管理等)被存储。主电源断电(供电故障)又恢复后或产品重新启动后，输出状态可在  **Profile** 菜单中设置。

6.5 打开功率输出

 按下**ON**按钮，只要未被内部模拟接口的“REM-SB”输入引脚(13)或插上的模拟接口卡“Standby”输入引脚(11)阻止，因为这两引脚有最高优先权，即可打开电源输出。如果其中一引脚阻止按钮打开输出，显示器会指示“**auto ON**”状态文字，提示用户，一旦该引脚的阻止，即可打开输出。





注意：在local状态下(见章节6.9)，模拟接口(内部或外部)的引脚REM-SB是无效的。

显示器指示当前状态为“ON”。

 **OFF**按钮关闭电源输出(关断)。显示状态为“OFF”。

6.6 调节设定值

只要“extern”或“remote”未显示，都可手动调节电压、电流或功率设定值。

在产品设置  **Accept set value** 下选择模式，通过  **M** ->  **Profile** ->  **General settings** ->  **Control panel** 进入该设置。详情见“7.4 配置控制面板”。

直接设置设定值

用旋钮可直接设置设定值。

左旋钮调电压。当电压设定值被选定并调整时，数字反过来显示。

右旋钮既可以设置电流、功率(1kW型号起)设定值，也可以设置内阻设定值(当选择了U/I/R模式，且该模式已解锁)。选定的设定值反向显示于屏幕上。

用选择键

 **P** 选择功率设定值，或者用

 **R** 选择内阻设定值，或者

 **I** 选定电流设定值。

可限制最大可调功率。

设定值的提交

与设定值直接调节方式不同的，还可选择只有当提交设定值后用**RETURN**键方可设定这些参数。详情参考“7. 产品设置”。设定值仍可用旋钮来更改，但只要没有提交就不会传到输出端。设定值未被修改时，只有单位才反向显示。修改后数值和单位都反向显示。

SELECT键可从电流调节转至功率调节，用右旋钮调节。此时选择的设定值未提交，也未设定。

 按下**RETURN**键就提交设定值。

 **ESC** 按下**ESC**键则取消新设定值，显示旧值。

注意：设定阻值的调节仅在解锁了“内阻控制”选项(见章节7.8)后才可执行。

可从0Ω至20 Unom/Inom调节设定内阻。意思是，举例：当产品的Unom = 65V和Inom = 10A，那我们可就可将它调至最大130Ω。*

使用预设值

在菜单  **Preset List** (见„7.2 预定义预设清单“) 下有一个由4组设定值组成的表格。用左旋钮选择预设清单, 用**RETURN**按钮提交设定值, 或用**ESC**按钮放弃使用。

 选定的设定值组目前仍为1。按下**RETURN**按钮后, 第3组设定值被提交给店员。显示器则显示新的设定值组, 第3组。

 **MEMORY**按钮可用来直接跳跃到定义预设清单的菜单页, 然后利用**RETURN**按钮, 按照正常方法进行编辑和提交。

设定值的调节步宽

电压			电流		
额定值	粗调	细调	最大值	粗调	细调
32V	200mV	10mV	4A	50mA	1mA
40V	0.5V	10mV	5A	50mA	1mA
65V	0.5V	10mV	10A / 15A	0.1A	10mA
80V	0.5V	10mV	20A / 30A	0.2A	10mA
160V	1V	100mV	40A / 60A	0.5A	10mA
360V	2V	100mV	120A	1A	100mA
720V	5V	100mV			

功率			阻值		
额定值	粗调	细调	额定值	粗调	细调
640/650W	5W	100mW	13.3/16Ω	100mΩ	10mΩ
1000W	10W	1W	26.7/32/40Ω	200mΩ	10mΩ
1500W	10W	1W	53.3/64Ω	500mΩ	10mΩ
3000W	20W	1W	130Ω	1Ω	10mΩ
			240/260Ω	2Ω	10mΩ
			480/720/800Ω	5Ω	10mΩ
			960Ω	10Ω	10mΩ

6.7 转换按钮面板

 **PAGE**按钮可转换至另一按钮面板。用户利用其他面板的新按钮锁定控制面板, 转至函数管理器或设置位置模式。

6.8 锁定控制面板



 “锁定按钮面板”按钮可锁住所有除它自身和旋钮外的任何其它键。这样产品被锁定后, 不可手动进入, 不能更改任何参数, 也不可进入任何菜单。在菜单下可设定锁定模式。于是可使控制面板完全失效, 或者用**OFF**键解除(产品被锁定但可通过**OFF**键打开和关闭)。可参考„7.4 配置控制面板“的“启动键盘锁定”。



 控制面板锁定后, 图标即变为这个。此按钮可用于再次解除控制面板的锁定, 如果

在下2s内按下此键, 图标即变成 。

6.9 更改位置模式

本产品可设置成不受远程控制或不允许用接口卡转成远程控制的模式。

 用**EXT**按钮, 用户通过数字或模拟接口卡可启动远程控制, 停用  **local**模式。

 用此按钮将产品设为严格的本地模式, 这样产品只可在本地受控 ( **local**), 即只能手动操作, 拒绝通过任何模拟或数字接口进入。

6.10 转至函数管理器

 **SEQ**键将显示屏转至函数管理模式。

只有当产品处于待机状态(输出=关闭)时方可转至函数管理器。且当前的电压、电流设定值为0V和0A。详情请参考章节„6.15 函数管理器“。

6.11 激活菜单

 主菜单通过**MENU**键进入, 显示屏转换到主菜单界面, 出现如下文本菜单:

-  **Profile** 设置和选择用户配置文档
-  **Function** 设置函数列
-  **Analogue interface** 设置内部模拟接口
-  **Communication** 配置可插拔式接口卡
-  **Options** 默认设置, 解锁功能, 锁定产品配置
-  **About...** 生产商, 服务, 软件版等

 按**ESC**按钮将进入上一级菜单页。

  按**SELECT**键选择进入另一个菜单。

 按**RETURN**键进入下一级子菜单。菜单最后一级总以参数页显示, 详见下一个主题。

6.12 参数页

参数页为菜单最底级。在这您可更改多种不同参数来设置产品。



按ESC键进入参数页的上级菜单，不再接受任何参数。



用SELECT键选择不同参数。所选参数会反向显示，用左旋钮可进行更改。



RETURN键将更改后并被接受和保存的参数提交出去。并退出参数页面，进入下一个上级菜单。

6.13 报警、警戒和信号提示

报警，警戒和简单提示(此被称作“信号提示”)以声音或可视信号发出(见章节„7.4 配置控制面板“)。

报警要优先于警戒或信号提示。一次可显示多至四种报警，警戒或信号提示，且以每两秒间隔时间循环一次。如显示的信号超过四个，再有报警出现，前面的警戒或提示信号将被取消，用报警替代。

本电源监控接口卡的传输错误，用户设置的警戒和报警信息。输出电压，输出电流，及真实值与设定值间的差异都能监控到。

下表列出可能出现的错误种类和其代表意义，产品可配置的可选错误种类。

报警 会关断输出，必须确认后才可重新启动输出(见„6.14 报警和警戒的确认“)。

警戒 如未被确认则一直显示于屏幕。如果“auto ON”由于某一特殊故障被激活，则暂时关断电源输出。例如：在系统链接模式下从属电源的输入电压瞬间缺失。

提示信号 仅显示，并持续至故障原因消失。如出现超过一个以上的提示信号，它们将以2s的间隔时间循环显示。

6.14 报警和警戒的确认



用ACK键确认报警和警戒。

用此键确认了出现的警戒后，将转为信号并持续显示，不然被删除，不再显示。

6.15 函数管理器

函数管理器用于创建自动控制电源供应器的函数。函数f(U, I, Δt)建立后可将设定值转成曲线图。函数管理器每隔2ms设置设定值，意指只有2ms的倍数时间才能设定，比如：50ms。如果两点间的电压或电流改变，将形成一个由一定步骤组成的跳跃。(Δt:2ms, 形成25个步骤，如果设定值是50ms的话)

函数管理器控制电源，输入配置在函数内的设定值。输出值的实际发展由负载决定。

使用术语解释：

函数=由多达5组连接的序列头(在菜单 Setup function开始)构成，而一个函数可组成多达五组不同的配置序列。

函数排布=通过函数管理器在函数布局下的配置，可设定电源操作模式(U//P 或 U//R)。而且还可在此处设定函数的重复率和序列的任意秩序。根据函数布局，函数管理器在上个序列完成后处理下一列，并使用下列的序列控制设定值。

序列=由序列控制和10个序列点构成。如果函数管理器即将处理一序列，首先设定序列控制给出的参数，连续设定10个序列点，按照某特定序列设定的重复率，重复整个处理程序。

序列控制(Sequence control) =定义序列重复率和序列处理过程中最大功率设定值与内阻(选项，必须解锁)。

显示	错误类型			根据	描述
	报警	警告	简单提示		
OV	·				电源输出端过压
SYS	·				一般系统错误
FCT	·				不能存储和/或不能提交函数
OT	·			1)	过温错误
				2)	
CAN		·			CAN总线传输错误
U>	def.	def.	def.		超过过压监控阀值
U<	def.	def.	def.		超过欠压监控阀值
I>	def.	def.	def.		超过过流监控阀值
I<	def.	def.	def.		超过欠流监控阀值
U↗	def.	def.	def.		正向电压转换时设定值比较出错
U↘	def.	def.	def.		负向电压转换时设定值比较出错
I↗	def.	def.	def.		正向电流转换时设定值比较出错
I↘	def.	def.	def.		反向电流转换时设定值比较出错
P↗	def.	def.	def.		正向功率转换时设定值比较出错
P↘	def.	def.	def.		反向功率转换时设定值比较出错

1) OT disappear = OFF

2) OT disappear = auto ON

def. = 可定义

序列点=一个序列通常由10个序列点组成。序列点由函数管理器从0点到9点连续处理。序列点的定义决定了要在给出时间 Δt 内达到设定的电压、电流值。这使得用户通过设定0ms或2ms的阶跃函数和4ms至99h99m时间坡度，创建阶跃函数。还可设定0ms的时间，但形成的真实时间会是2ms，因为设定值是以2ms为一阶跃阶段。

除函数外，您可设置和使用用户化设置内的监控电路。也可通过接口卡的链接控制函数管理器，其特点：您可在函数将要停止的地方设置一暂停点。

6. 15. 1 配置函数



菜单页 **Function** 指向下列菜单选项：

- Setup function**
- Sequence 1**
- Sequence 2**
- Sequence 3**
- Sequence 4**
- Sequence 5**

6. 15. 2 函数布局



此处可定义电源的操作模式和重复率。

◆ **Function mode**

- = U//P 函数使用U//P运作模式
(仅针对1kW以上且有功率调整功能的型号)
- = U/I 函数使用U/I运作模式
(仅针对640W以上且有功率调整的型号)
- = U//R 函数使用U//R运作模式
(仅当“内阻”选项解锁后)

也可见章节,,7.1 定义操作参数“。

◆ **Funct.cycles**

- = {1..254} 循环n次
- = ∞ 无限制循环

◆ **Link sequences to one function**

- Task:** 1 2 3 4 5
Seq.: {-,1..5} {-,1..5} {-,1..5} {-,1..5} {-,1..5}

用户可针对特定任务定义函数由哪一序列组成，以何种顺序排列。图标“-”表示该任务未被定义，因此将不被处理。

函数管理器显示总图：



图 6

6. 15. 3 配置序列

菜单页  **Sequence {1..5}** 指向序列编辑页。

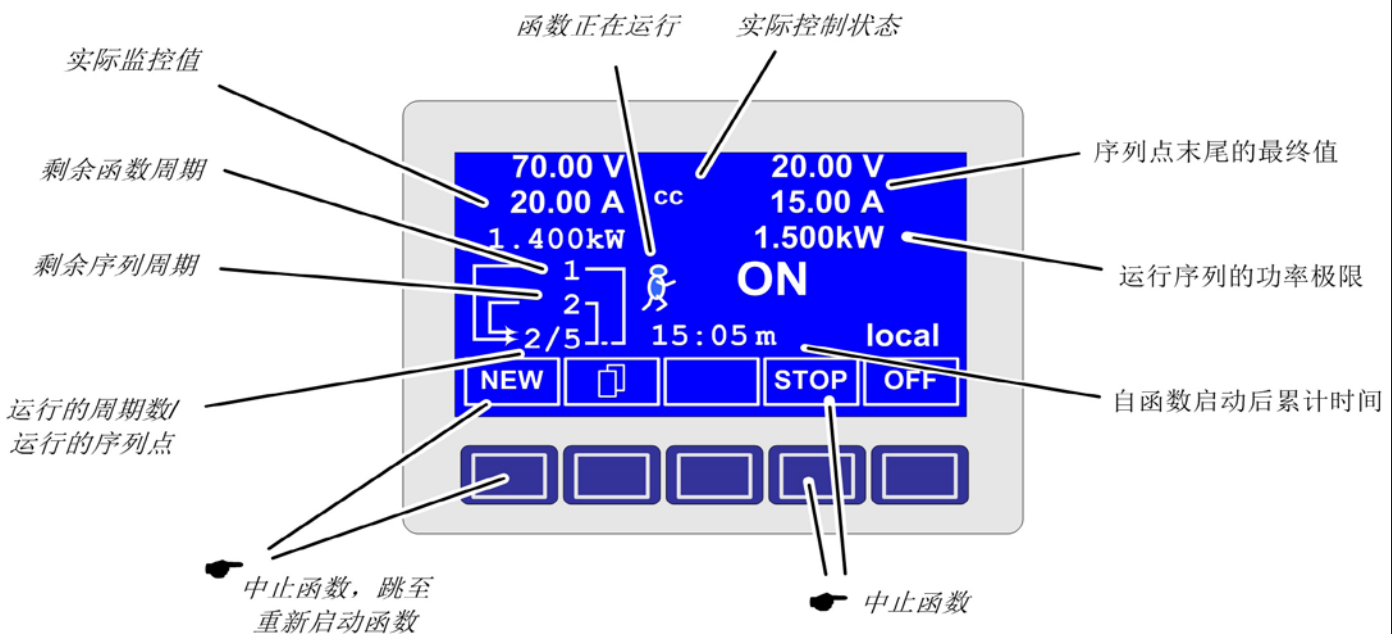

指向下列菜单选项：

 **Sequence {1..5}** (要编辑的序列数)

 **Sequence control**

 **Sequence points 0-4**

 **Sequence points 5-9**

此处可设置序列重复率，最大功率和内阻(可选，要解锁)，以及序列点。

6. 15. 4 与序列有关的参数



 **Function mode : U/I/P**

显示电源供应器的函数模式。

◆ **Seq. cycles {1..254, ∞}** 默认: 1

= {1..254} 重复n次
= ∞ 重复无数次

◆ **P seq= {0...P_{nom}}** 默认: P_{nom}

此处的最大功率影响整个序列。

仅在选择“内阻”项的情况下(可解锁)：

◆ **R seq= {0Ω...20 * R_{inom}}** 默认: R_{inom}

此处的最大内阻影响整个序列。

6. 15. 5 定义序列点



一个序列由10个序列点组成。一个序列点由3组数据组成：电压U, 电流I和时间Δt的设定值。

◆ **Δt = { 0...99:59h}**

◆ **U[V] = { 0... U_{nom}}**

◆ **I[V] = { 0... I_{nom}}**

要了解序列如何处理，您需考虑每个序列周期的开始条件：

函数开始的设定值

函数通常这样开始

$U_{set} = 0V$ 和 $I_{set} = 0A$

再进入序列的设定值

如果序列重复，最后被处理的序列将改变下个序列循环的开始条件。

比如：将序列点9设为80V/50A/250ms，重复运行该序列，于是序列以80V/50A，和之前设为0序列点（如：500ms）的时间开始循环。在500ms这个时间段内，设定值将以线性地接近0序列点的定义值。

6. 15. 6 函数运行时的显示

也可见上页总图。



 **70.00 V**
35.00 A
1400kW 真实值显示

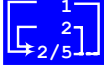

在显示器左边，真实值以小字体显示。运行的控制状态(CV/CC/CP)显示在对应值的右边。

 **20.00 V**
15.00 A
1500kW 序列处理完后即将到达的序列点设定值，显示于

屏幕右边。

  显示函数运作的状态，函数(1)和序列(2)的剩余重复次数，当前序列号(2/_)和现时运行的序列点(_/5)。

  表示函数管理器暂停或尚未开始。

  函数管理器正在运行。

 **15:05 m** 函数发生器启动后的累计时间也会显示出来。函数管理器停止，时间显示才停止。**STEP**, **RUN**或**GO**键以多种方式操作函数管理器，同时时间显示会持续累计。

 **{ON,OFF}** 电源输出状态

除电源输出状态外，还显示报警，警戒或信号提示状态。

6. 15. 7 函数管理器的控制

交互式控制面板给函数管理器提供多个控制键。利用这些按键用户可暂停、继续、重设为起始点或退出函数管理器。

比如：待机时的模拟显示如下：

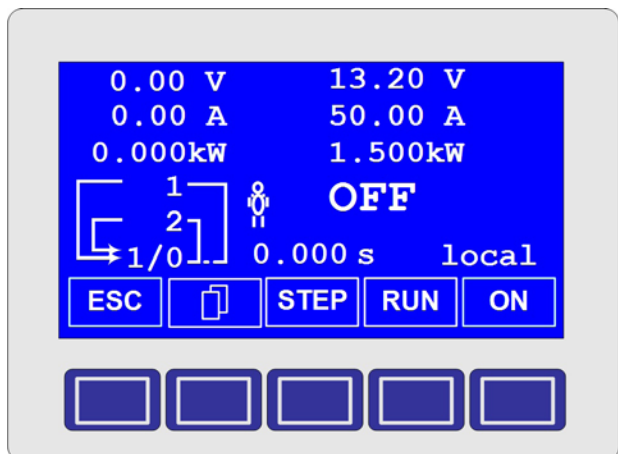

函数管理器真正设定电源前，可在显示屏幕上模拟此函数。在此操作过程中

- 不可打开输出，且

- 一步一步处理这些序列点，并按相同方法检验。

也可通过接口卡执行此操作。还可在50个序列点中额外地设置一停顿点。处理到这个点时，序列、函数就会暂停。

ESC **ESC**键退出函数管理，并返回电源的前一状态。

STEP **STEP**键逐步运行序列。按下此按钮，执行当前序列点。完成这个后，显示于屏幕右上角的设定值被设定。

RUN **RUN**键启动函数管理器，按定义值运行函数，然后持续处理序列点。

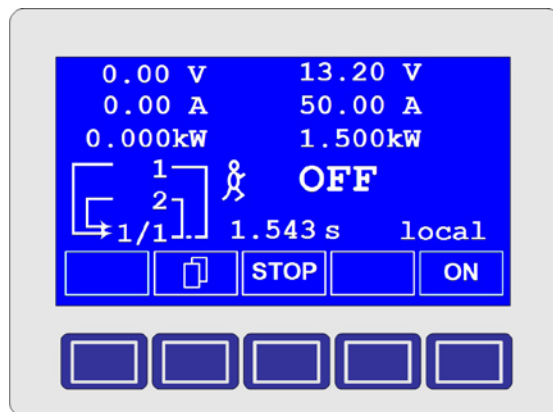

GO 用**GO**键继续运行停止后的函数。

NEW 或者用**NEW**键可重设函数管理器，开始执行当前函数。

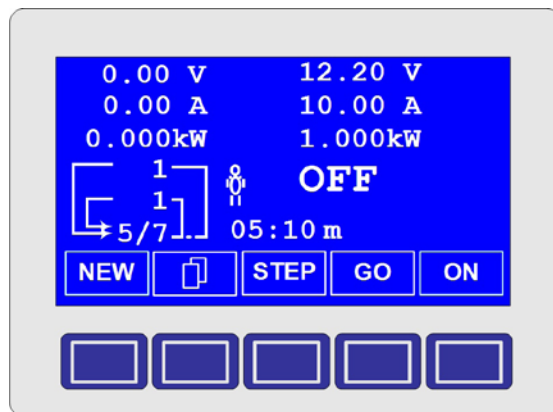

7. 产品设置

第1部分: Profile菜单

注解:
 选项: 内阻
 并非针对每个型号

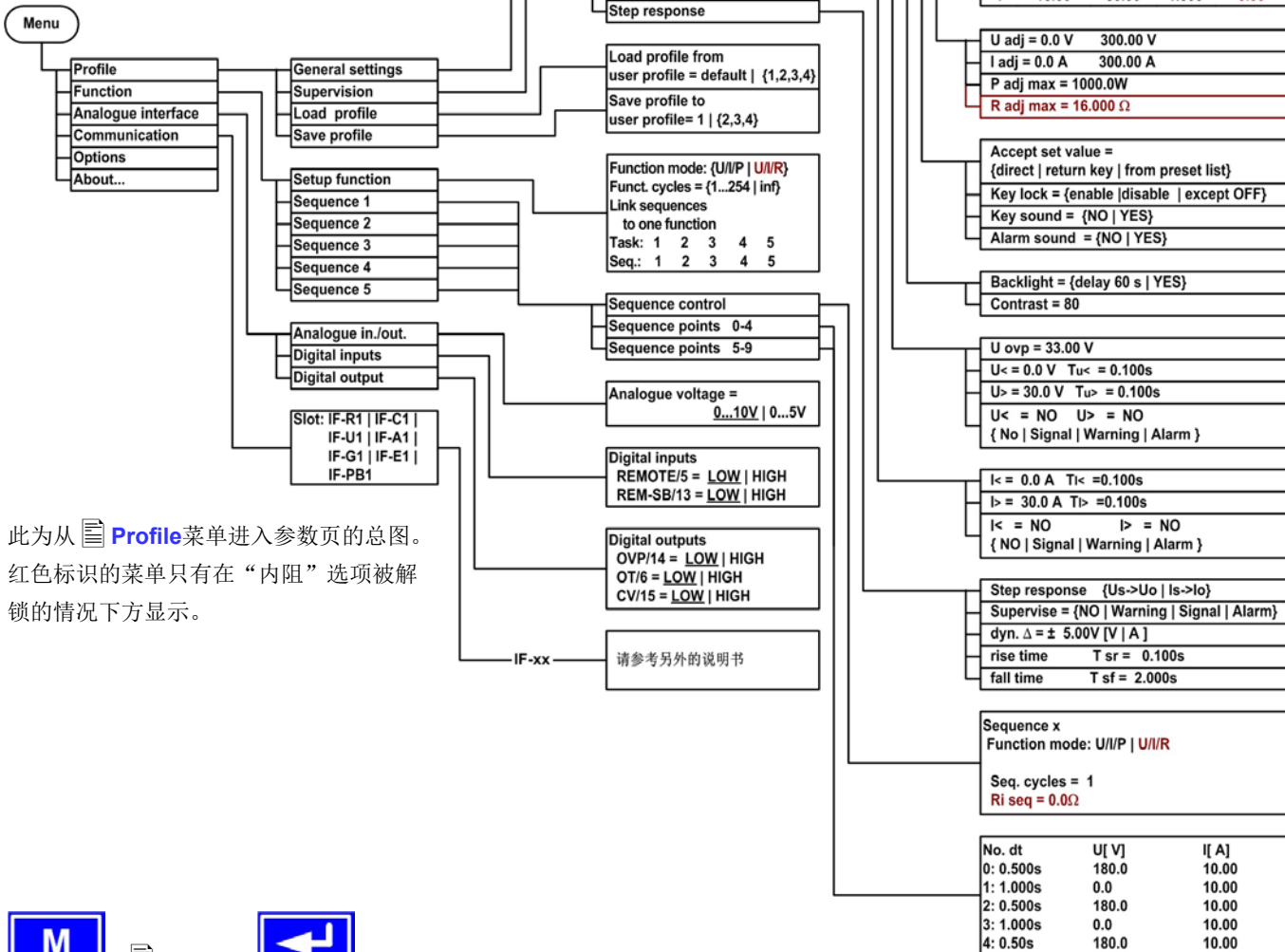

此为从 Profile菜单进入参数页的总图。红色标识的菜单只有在“内阻”选项被解锁的情况下方显示。



该配置文件意在减少不同用户设置产品时所需时间，或保留用户定义的设置参数，以便将来重复使用。最后使用的配置文件总在电源启动后上载。

进入 Profile菜单将出现下列选项:

- General settings
- Supervision
- Load profile
- Save profile



进入 General settings菜单，指向下列选项，可配置操作模式，显示界面，产品处理(调节):

- Setup operation mode
- Preset list
- Adjust limits
- Control panel
- Display



进入 Supervision菜单，指向下列选项，可对报警、警戒和信号提示，还有相应监控限制和反应时间进行设置。

- U thresholds
- I thresholds
- Step response



◆ Load profile from user profile = {default, 1..4}
 当前配置文件被所选配置文件表代替。



◆ Save profile to user profile = {1..4}
 当前配置文件被存储于四个配置文件中的其中一个。

7.1 定义操作参数



在此可设置设定值的调节方式，即将使用的操作模式，主电源供电恢复后产品如何反应的设置，或产品出现过温异常后的行为。

U/I/P 或 U/I/R 操作模式

- ◆ **Setup op. mode** 默认: U/I/P
- = U/I/P 功率级由设定电压、电流和功率（仅针对1kW以上且有功率调整的型号）控制。
- = U/I 功率级由电压和电流（仅针对640W以下型号）控制。
- = U/I/R 功率级由电压、电流和内阻设定值，以及可设不可调的功率设定值（仅当“内阻控制”选项解锁后）控制。

注意: U/I/R操作模式只有在 **Options** 菜单中解锁后方可使用。解锁码可从售货公司买到。当购买产品时应要求告知序列号，因为解锁码与此相关。
在U/I/R操作模式下，您可为电压源增加可调内阻。

设定电压与电源的空载电压 U_0 有关。 I_{act} 乘以 $R_{i, set}$ 可减少空载电压。该电压值的计算公式如下:

$$U_{set} = (U_0 - I_{act} \cdot R_i) \left| \begin{matrix} I_{set}, P_{set} \end{matrix} \right.$$

图形解释:

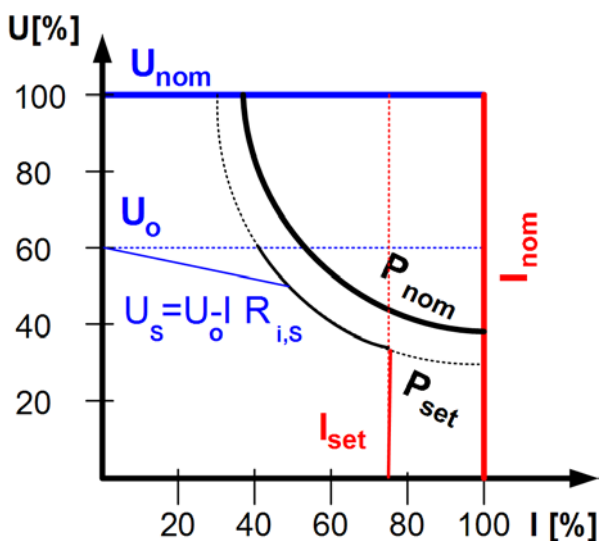
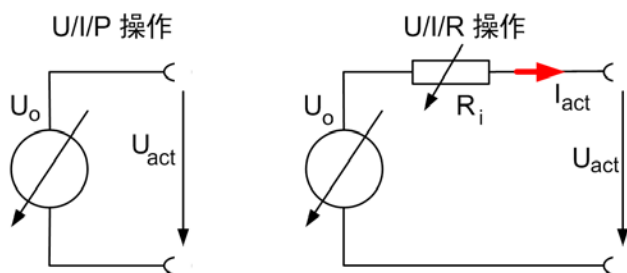

CR 当内阻控制被激活，且设为U/I/R操作模式，将显示这个图标。

U/I/R模式被激活时，显示内阻 $R_{i, set}$ 而不是功率 P_{set} ，但是功率实际值仍然显示。

过温错误之后的恢复

◆ **OT disappear** 默认: auto ON
= OFF 即使电源已经冷却，电源输出仍关闭。

错误...

OT (过温)以报警形式显示。
= auto ON 当电源冷却到过温关闭极限以下，会自动打开。

错误...

OT (过温)以警戒形式显示。
警戒与报警一样，只有当此动作被确认后从显示屏消失(见章节.6.13报警、警戒和信号提示“)。

“电源打开”后的输出状态

◆ **Power ON** 默认: OFF
= OFF 市电恢复或电源被打开后电源输出仍为关闭。
= restore 电源供应器输出恢复到市电断电或电源供应器被关闭之前的状态。如果关闭产品时电源状态为ON，再次启动后，输出仍为ON。

7.2 预定义预设清单



可预先定义4组不同预设值。

No.	U[V]	I[A]	P[kW]	R[Ω]
1:	0.00	0.00	1.500	20
2:	10.00	10.00	1.200	25
-:	0.00	0.00	1.500	50
-:	0.00	0.00	1.500	100

阻值(红色)仅在U/I/R模式解锁的情况下出现。
功率值(绿色)仅针对1kW以上型号产品。

利用参数 ◆ **Accept set value = from preset list** 您可从正常设定值转换到其中一组预设值，或在两组预设值之间转换。通过此选项实际上可在设定值之间“跳跃”。

7.3 调节极限



在此可定义最大和最小调整极限。这些极限常常在本地或远程模式(即：产品由电脑控制)下受干扰。

电压设定值极限

◆ **U adj** 默认: 0V, U_{nom}
= { $U_{adj.min}$ } { $U_{adj.max}$ }

反之 $U_{adj.min} = \{0 \dots U_{adj.max}\}$ and $U_{adj.max} = \{U_{adj.min} \dots U_{nenn}\}$

在此可定义可调电压的上限和下限。超出极限的设定值不被接受, 不管是由控制板还是由电脑远程控制(通过接口卡通讯)产生。

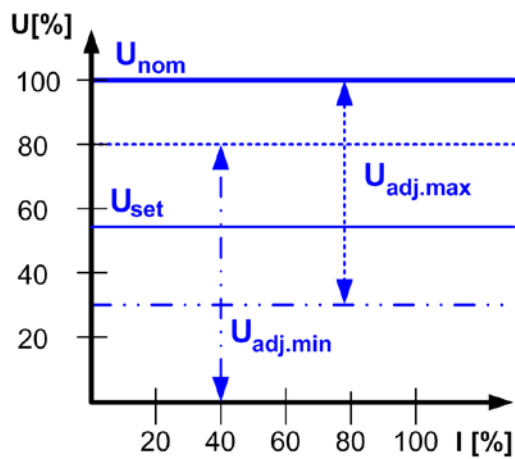

电流设定值界限

◆ **I adj** 默认: 0A, I_{nom}
= { $I_{adj.min}$ } { $I_{adj.max}$ }

反之 $I_{adj.min} = \{0 \dots I_{adj.max}\}$ and $I_{adj.max} = \{I_{adj.min} \dots I_{nom}\}$

在此可定义可调电流的上限和下限。超出极限的设定值不被接受, 不管是由控制板还是由电脑远程控制(通过接口卡通讯)产生。

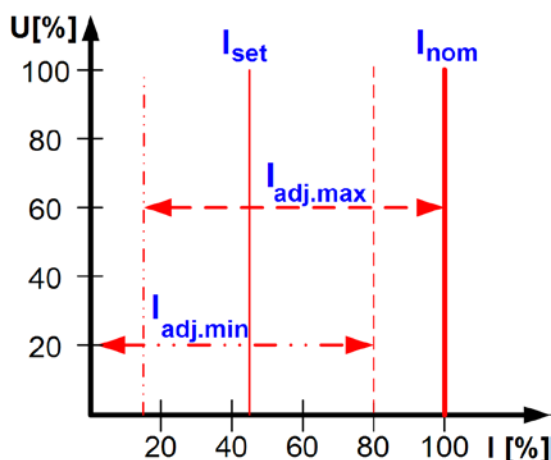

功率设定值极限 (仅针对1kW以上型号)

◆ **P adj max** 默认: P_{nom}
= {0kW... P_{nom} }

在此可定义可调功率的上限和下限。超出极限的设定值不被接受, 不管是由控制板还是电脑远程控制(通过接口卡通讯)产生。

内阻设定值极限

(可选项, 仅在U/I/R模式解锁情况下)

◆ **R adj max** 默认: 0 Ω
= {0 Ω ...20 * R_{inom} }

如果U/I/R模式已解锁, 您可定义可调内阻的上限和下限。超出极限的设定值不被接受, 不管是由控制板还是由电脑远程控制(通过用接口卡通讯)产生。

7.4 配置控制面板



菜单页 **Control panel** 能让您设置所有与图显和控制面板有关的参数。

配置设定值的手动调节方法

- ◆ **Accept set value** 默认: **direct**
- = **direct** 用旋钮更改设定值后, 直接设为产品功率级。
 - = **return key** 仅当用**RETURN**键提交后方可设定更改后的设定值。
 - = **from preset list** 用旋钮从 **Preset List**选择设定, 然后用**RETURN**按钮提交。

控制面板的锁定

仅能在此配置控制面板的锁定。

- ◆ **Key lock** 默认: **except OFF**
- = **except OFF** 控制面板(按键和旋钮)将被锁定, 但是**OFF**键除外。
 - = **enable** 控制面板将完全被锁定。
 - = **disable** 不锁

控制面板的锁定是为了避免对设定值或其它设置进行不需要的更改。

注意: 该设定仅为临时性设定。产品重新打开或者断电后重获市电, 该设定会重置 (=失效)。

声音

- ◆ **Key sound** 默认: **NO**
- = **YES** 按键有短“嘀”音提示
 - = **NO** 按键无声响

◆ **Alarm sound** 默认: **YES**

- = **YES** 如出现报警或警戒, 每间隔一短暂时间即发出“嘀”音信号。
- = **NO** 报警/警戒不带声音信号

7.5 配置图行显示器



菜单页 **Display** 设置所有与图显相关的参数。

- ◆ **Backlight** 默认: YES
 - = YES 背光灯常亮
 - = delay 60s 最后一次使用按键或旋钮, 60s后背光灯关闭。

- ◆ **Contrast** 默认: 80%
 - = { 70%...90% }

可按产品安装位置和能更清晰地观看数值来调节对比度。

7.6 监控



菜单页 **Supervision** 配置对输出电压、电流和功率的监控, 也可对阶跃函数监控。 **Supervision** 菜单页指向下列选项:

- ☰ **U thresholds**
- ☰ **I thresholds**
- ☰ **Step response**

7.6.1 电压监控



菜单页 **U thresholds** 设置过压极限 (OVP), 以及过压与欠压的监控电路。

过压保护 (OVP)

- ◆ **U ovp** 默认: $1,1 * U_{nom}$
 - = { $U > \dots 1,1 * U_{nom}$ }

精确度: U_{nom} 值的0.3%
分辨率: 4 位数
响应时间: <math> < 100\mu s </math>

过压保护意在保护电源输出。若还要保护负载, 也将过压保护值调至负载的最大允许电压。如果输出达到该极限会被即刻关断。

举例: 一台80V产品的 U_{ovp} 最大能调到88V。

 **OV** 这个是以报警显示的过压保护。(见章节, 6.13 报警、警戒和信号提示 “)

过压监控

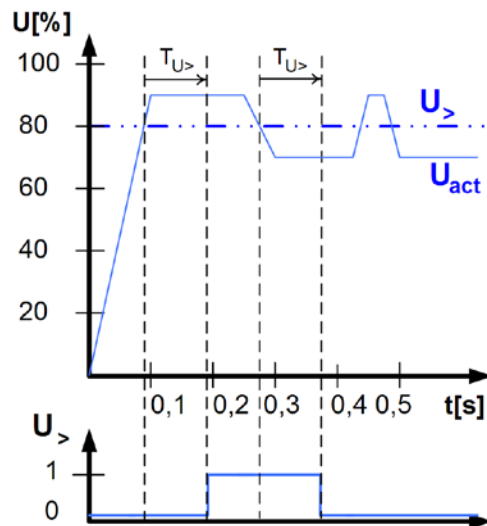

- ◆ **U>** 默认: U_{Nom}
 - = { $U < \dots U_{ovp}$ }

- ◆ **Tu>** 默认: 100ms
 - = { 0...99:59h }

这与OVP(见上述)有稍微不同。在这也监控电压, 但过了定义的延时 ◆ **Tu>** 时间后, 以报警, 警戒或信号提示告知用户。如果在 ◆ **Tu>** 时间内电压下降至极限以下, 该信号消失。因此您不是每次收到OVP错误信息, 或者过压出现时间大于定义 ◆ **Tu>** 时间时只听到报警声, 也可监控过压。

 **U>** 报警: 过压

此错误关断电源输出。必须确认报警错误后, 才能再次打开输出。

 **U>** 警戒: 过压

此错误出现后并持续存在, 直到信息被确认方才消失。

 **U>** 信号提示: 过压

欠压监控

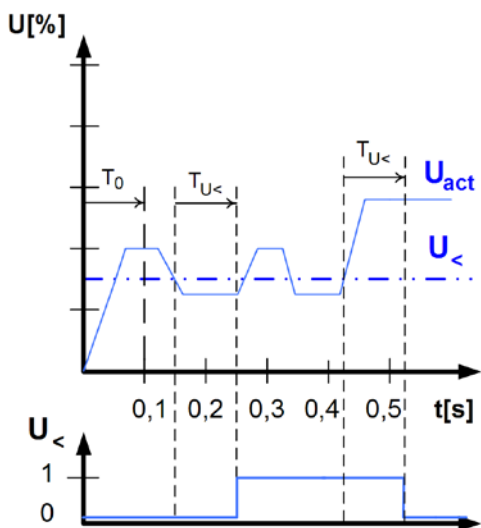

◆ **U<** 默认: 0V
= { 0... U> }

◆ **Tu<** 默认: 100ms
= { 0...99:59h }

电压一下降至欠压极限以下，过了响应时间◆**Tu<**后，发出欠压信号。如果在◆**Tu<**内超过欠压极限，信号消失。在电源输出打开后，欠压错误仅维持**T0=100ms**。

U< 报警：欠压

此错误关断电源输出。必须确认报警信息后，才能再次打开输出。

U< 警戒：欠压

此错误出现后并持续存在，直到信息被确认后方才消失。

U< 信号提示：欠压

模拟接口(IF-A1,可选)可从其中一数字输出端发出过压或欠压信号。

7.6.2 电流监控

I thresholds +

菜单页 **I thresholds**配置欠流和过流监控电路。

欠流监控

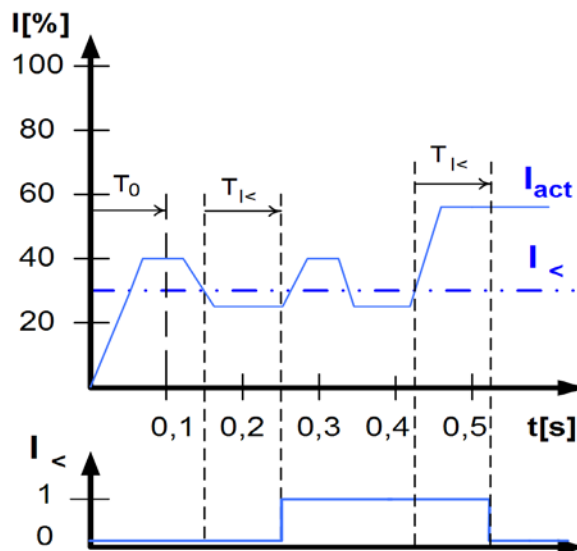

◆ **I<** 默认: 0A
= { 0... I> }

◆ **Ti<** 默认: 100ms
= { 0...99:59h }

如果电流实际值降至已调欠流极限以下，过了响应时间◆**Ti<**后，发出欠流错误信号。如果在◆**Ti<**内实际电流超出极限，错误提示消失。再电源输出打开，欠压错误仅维持**T0=100ms**。

I< 报警：欠流

此错误关断电源输出。确认报警信息后，才能再次打开电源输出。

I< 警戒：欠流

此错误出现后并持续存在，直到信息被确认后方才消失。

I< 信号提示：欠流

过流监控

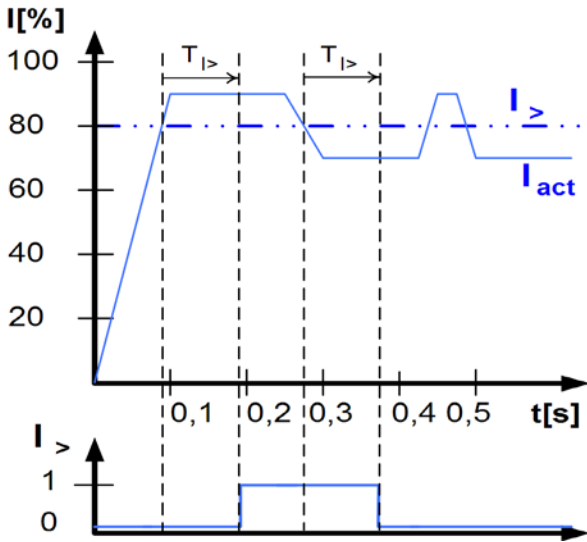

◆ $I >$ 默认: I_{Nom}
 = { $I < \dots I_{Nom}$ }

◆ $T_i >$ 默认: 100ms
 = { 0...99:59h }

如果实际电流降至已调过流极限以下, 过了响应时间 ◆ $T_i >$ 后, 发出过流错误信号。如果实际电流在 ◆ $T_i >$ 内超出此极限值, 错误提示消失。再电源输出打开后, 过压错误仅维持 $T_o = 100ms$ 。

🖨️ $I >$ 报警: 过流

此错误关断电源输出。必须确认报警信息后, 才能再次打开电源输出。

🖨️ $I >$ 警戒: 过流

此错误出现后并持续, 直到信息被确认后消失。

🖨️ $I >$ 信号提示: 过流

模拟接口 (IF-A1, 可选) 可从其中一数字输出端发出过流或欠流信号。

7.6.3 阶跃响应监控

📄 Step response +

菜单项 Step response 配置实际值与设定值的动态和静态比较监控电路。

◆ Step response: 默认: $U \rightarrow U_o$

$U_s \rightarrow U_o$ 监控设定电压和实际电压的偏差
 $I_s \rightarrow I_o$ 监控设定电压和实际电压的偏差

◆ Supervise Default: NO

NO 监控未启用
 Signal 监控报告一信号
 Warning 监控报告一警戒信息
 Alarm 监控报告一报警信息

◆ dyn. Δ 默认: 10%
 = 8.00V 电压允许误差
 = 5.00A 电流允许误差

电源供应器的设置过程取决于负载。当一组设定值被更改后, 要过一定时间才能将期望值传到电源输出端。比如: 在无负载操作下, 要用几秒钟的时间电压才从100%降到0V, 因为输出电容需要一定的时间放电。

一个阶跃响应的监控

已调设定值与真实测量值进行比较。如果它们之间有差异, 且差异大于误差值, 过了设定时间 ◆ T_{sr} 后, 监控器将发出错误信号。见下面数据: .

◆ rise time

$T_{sr} = \{ 0 \dots 99:59h \}$ 默认: 100ms

◆ fall time

$T_{sf} = \{ 0 \dots 99:59h \}$ 默认: 2s

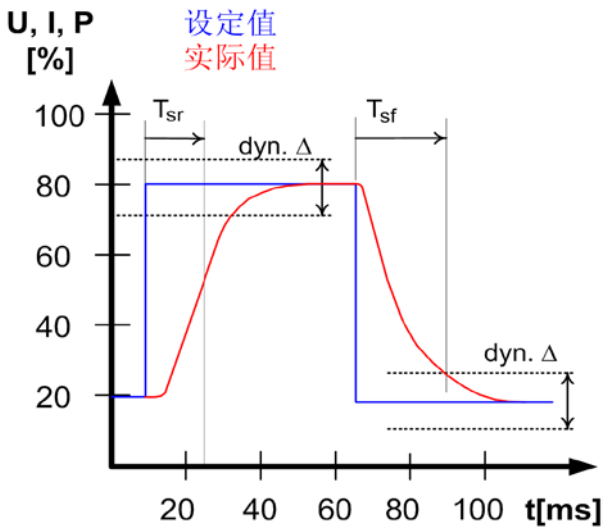

设定/真实值比较的通知

例如: 如果在设定时间 ◆ T_{sr} 内未完成较低设定值到较高设定值的跳跃, 就会发出报警、警戒或信号提示类的监控错误。

🖨️ $U \nearrow$ 或 🖨️ $U \nearrow$ 或 🖨️ $U \nearrow$

根据 Step response 的配置, 错误以 $U \nearrow$ 发出通知。

例如: 如果在设定时间 ◆ T_{sf} 内未完成较低设定值到较高设定值的跳跃, 就会发出报警、警戒或信号提示类的监控错误。

🖨️ $U \searrow$ 或 🖨️ $U \searrow$ 或 🖨️ $U \searrow$

根据 Step response 的配置, 错误以 $I \searrow$ 发出通知。

第2部分：菜单  Options

进入菜单  Options 有下列选项：

 **Reset configuration**

 **Enable R mode**

 **Setup lock**

7.7 恢复至默认配置

您可将所有设定的修改恢复到默认状态(产品出厂时的状态)。进入选择相应菜单后，会再次提示您，是否选择恢复您当前的个人设置。

注意：即使产品配置用PIN码锁定，也会被该设置解锁和覆盖！

◆ **Are you sure ?**

默认：NO

- = YES 恢复所有默认设置的修改
- = NO 不更改

7.8 解锁U//R运行模式

 R mode available:

- YES U//R运行模式锁定已解除并可用
- NO U//R运行模式还不可用

U//R运行模式只有用PIN码解锁后才可用。并在配置文件中进行检查配置。(见“7.1 定义操作参数”)

解锁U//R运行模式的识别码要另外购买。如果您有意使用此模式，在订购该产品时一起购买，也可以以后再订购。

◆ **Activate R mode via pin code: 0 0 0 0**

在此处使用您从供应商购买的识别码。

可从0Ω至(产品的) 20* Unom/Inom调节设定阻值。

7.9 锁定产品配置



为安全起见，有必要将产品配置锁定。在此输入的识别码由4组数字组成，每组数字都从0到15中选择。

◆ **Lock setup via** 输入识别码
pin code: {0..15} {0..15} {0..15} {0..15}

只有输入相同识别码或用  **Reset configuration** 恢复设置才能解除此锁定功能。后者将取消用户化配置，所以应仅在忘记识别码的情况下使用。

如用识别码锁定，再次输入识别码后才能更改设置，此时设置被解锁。

注意！ 这仅对产品的用户化配置有影响，非产品设定值或前板上的旋钮！

8. 数字接口卡

8.1 一般信息

该电源支持多种通讯(或模拟控制，用IF-A1)接口卡。所有卡都耐压2000V。

数字接口卡IF-R1 (RS232)，IF-C1(CAN) 和 IF-U1(USB) 使用统一的通讯协议。一旦配上这些卡，一台电脑可一次性控制多达30台电源供应器。

GPIB数字接口卡IF-G1 (IEEE 488)卡为每条总线上的多台产品提供一个SCP指令结构。模拟卡IF-A1电隔离，带可配置的输入、输出模拟接口。

新款以太网/LAN卡 IF-E1也提供SCPI指令集。它还特别配了一额外的USB端口，能够藉由IF-U1卡访问产品。

还有一款Profibus接口卡IF-PB1，它使整套总线接口卡更完善。这种卡连带GSD/GSE文件。经Profibus卡，可设定和监控电压、电流、功率和产品状态，按客户需求还可配备其它功能。该卡也有一额外的USB端口，用于固件更新或选择USB卡IF-U1来控制产品。

8.2 配置接口卡

接口卡须被配置一次，然后每次被替代。通过菜单  **Communication** 完成。



 **Slot:** { IF-... } 根据本机原配型号

◆ **Device node**

默认：1

- = {1..30} 总共可给一台产品配置30个设备结点(地址)。如果是控制多台产品，一个设备节点仅能分派一次。

当插上Profibus接口卡IF-PB1后，则有如下：

◆ **Profibus address**

默认：1

- = {1..125} 可从最多125个可能的地址内给从机选择一个。该设定仅当Profibus卡IF-PB1插入后方有效。

本产品会自动识别插上的接口卡。菜单选项显示插入卡的产品编号。

配置不同的卡

因为不同的卡有不同的参数要配置，这些在相应卡用户手册中有详细描述。请见那些参考。

9. 内置模拟接口

9.1 一般信息

内置15芯模拟接口位于产品后板，结合其它工具实现下列功能：

- 远程控制电流和电压
- 远程控制0...100%输出功率 (仅针对1KW以上且带功率调整功能的型号)
- 远程监控(OT, OVP, CC, CV)状态
- 远程监控实际值
- 远程打开/关闭输出

使用提示：

- 用模拟电压来控制产品需用“REMOTE”(5)引脚转为远程控制模式。
- 连接控制电源的应用设备前，要保证所有线连接正确，并检查应用设备不会输入高于指定电压的电压（最大12V）。
- REM-SB (远程待机, 13引脚)输入引脚要优先于Output On按钮。意思是，如果该引脚定义输出状态为“off”，就不能用按钮来打开输出，除  local模式激活以外。也可见章节6.9。
- VREF输出引脚给设定值输入脚VSEL、CSEL和PSEL创建设定值，如仅需电流控制，可将VSEL和PSEL脚连到VREF脚，然后通过一外电压(0...5V或0...10V)来供电，或通过VREF和地之间的电位器来给CSEL供电。也可参考下一章节。
- 如选择了0...5V电压范围，想输入高达10V的设定值，则高于5V以上的电压会被忽略（被限制），以保证100%的设定值。
- 模拟接口的地与输出负极相连。

9.2 模拟接口的设定



 Analogue in./out.

 Digital inputs

 Digital outputs

 Analogue in./out. 为模拟设定值输入脚和实际值输出脚选择电压范围：

◆ Analogue voltage 默认：0...10V

= 0...10V 为0...100%的设定/实际值选择0...10V电压范围。

= 0...5V 为0...100%的设定/实际值选择0...5V电压范围。

VREF脚的参考电压被自动调节到上述选择范围，变成5V 或 10V。

 Digital inputs 定义数字控制输入脚是在LOW或HIGH水平动作。

◆ REMOTE /5 默认：LOW

= LOW 如果该引脚连到LOW（地），产品转至模拟远程控制模式。

= HIGH 如果该引脚连到HIGH（地），产品转至模拟远程控制模式。

注意！该引脚默认连到HIGH。意即：若选择HIGH设定，且引脚未连接，则产品将永久停留在模拟远程控制模式下！

9.3 D-Sub插座总图

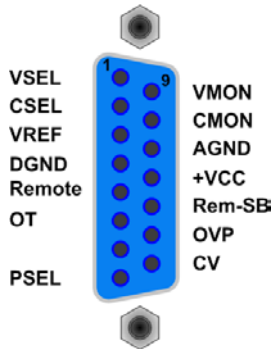

9.4 应用举例

注意！请勿将模拟接口的地接到外控设备（比如：PLC）的负输出端，如果连上，就表示控制设备连到了电源输出负极（形成接地回路），负载电流流经控制线，从而损坏设备！



图7



图8

9.5 各引脚分布说明

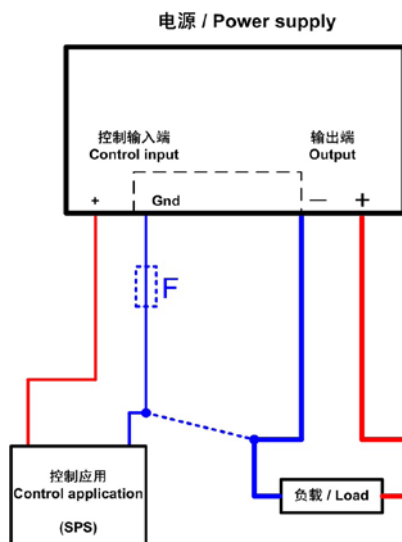
引脚	名称	类型 ⁽¹⁾	描述	水平	电气参数
1	VSEL	AI	设定值: 电压	0...10V 或 0...5V 对应 U_{Nom} 的 0..100%	精确度 < 0,1%
2	CSEL	AI	设定值: 电流	0...10V 或 0...5V 对应 I_{Nom} 的 0..100%	阻值 $R_i > 100k$
3	VREF	AO	参考电压	10V 或 5V	$I_{Max} = +5mA$ 时, 精确度 < 0.2% 短路保护对 AGND
4	DGND	POT	数字控制信号参考电位		+Vcc, 控制和状态信号
5	REMOTE	DI	在内控和外控间切换	外控 = LOW ⁽⁴⁾ , $U_{Low} < 1V$ 内控 = HIGH, $U_{High} > 4V$ 内控 = open	电压范围 = 0 ...30V 输出 5V 时, $I_{Max} = +1mA$ 发送: 开集电极对 DGND
6	OT	DO	过温错误	OT = HIGH, $U_{High} > 4V$ 无 OT = LOW ⁽⁴⁾ , $U_{Low} < 1V$	准开集电极上拉至 V_{cc} ⁽²⁾ 输出 5V 时, 电流最大 +1mA $U_{CE} = 0.3V$ 时, $I_{Max} = -10mA$ $U_{Max} = 0...30V$ 短路保护对 DGND
7	N.C.				不连
8	PSEL ⁽³⁾	AI	设定值: 功率	0...10V 或 0...5V 对应 P_{Nom} 的 0..100%	精确度 < 0.5% 阻值 $R_i > 100k$
9	VMON	AO	实际值: 电压	0...10V 或 0...5V 对应 U_{Nom} 的 0..100%	$I_{Max} = +2mA$ 时, 精确度 < 0.1% 短路保护对 AGND
10	CMON	AO	实际值: 电流	0...10V 或 0...5V 对应 I_{Nom} 的 0..100%	
11	AGND	POT	模拟信号参考电位		-SEL, -MON, VREF 信号
12	+Vcc	AO	辅助电压输出 (Ref: DGND)	11...13V	$I_{Max} = 20mA$ 短路保护对 DGND
13	REM-SB	DI	输出关闭	关 = LOW ⁽⁴⁾ , $U_{Low} < 1V$ 开 = HIGH, $U_{High} > 4V$ 开 = OPEN	电压范围 = 0...30V 输出 5V 时, $I_{Max} = +1mA$ 发送: 开集电极对 DGND
14	OVP	DO	过压错误	OVP = HIGH, $U_{High} > 4V$ 无 OVP = LOW ⁽⁴⁾ , $U_{Low} < 1V$	准开集电极上拉至 V_{cc} ⁽²⁾ 输出 5V 时, 电流最大 +1mA $U_{CE} = 0.3V$ 时, $I_{max} = -10mA$ $U_{Max} = 0...30V$ 短路保护对 DGND
15	CV	DO	指示电压调整启用	CV = LOW ⁽⁴⁾ , $U_{Low} < 1V$ CC = HIGH, $U_{High} > 4V$	

⁽¹⁾ AI = 模拟输入, AO = 模拟输出, DI = 数字输入, DO = 数字输出, POT = 电位

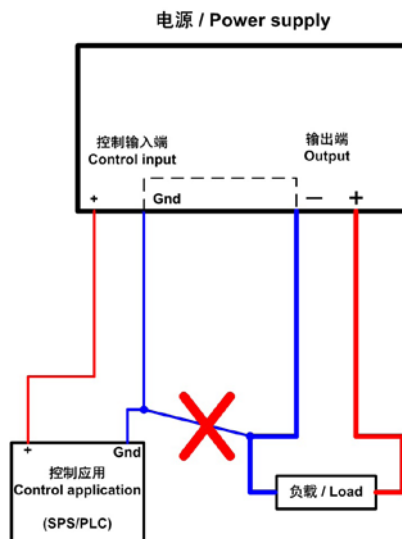
⁽²⁾ 内控 $V_{cc} = 13...15V$

⁽³⁾ 仅针对 1kW 以上型号

⁽⁴⁾ 默认设定, 可在产品设置下更改

输出关闭

“PREM-SB” 引脚一直都为工作状态，因此它不依靠远程模式。在不利用外部手段条件下用它可关闭输出，比如：当紧急关闭功能用。

用户需要做的就是确保合适的输入电压水平。

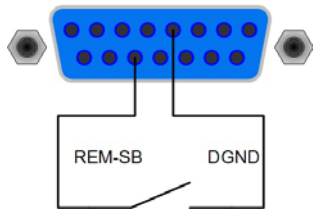

远程控制电流和电压

VREF和接地脚之间有两电位器，VSEL和CSEL输入端上有一滑动器。利用前板上的旋转编码器可控制电源，将它当作电流源或电压源用。如果VREF输出脚的电流最大为3mA，则需使用至少10kOhm的电位器。

这儿显示的是带功率调整特点的产品型号，功率设定值与紧密VREF相关，范围为100%。

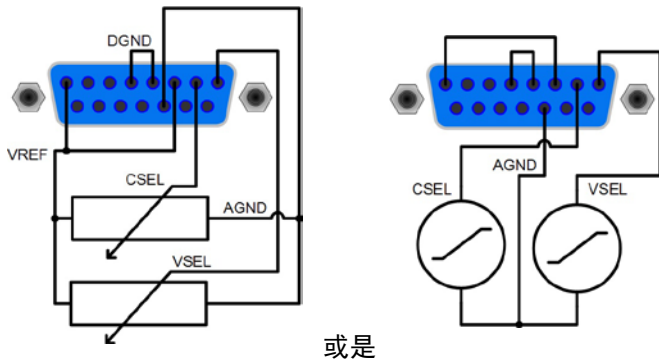

远程控制功率(当具有该功能时)

与上述例子相似，但是用可调功率极限来完成。功率调整仅在1000W以上且具有该功能的产品上工作。

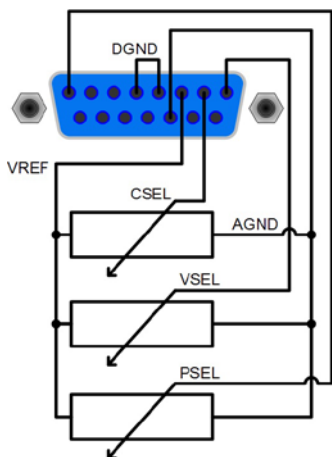

10. 其它应用

10.1 远程感测

远程感测操作用来补偿电源和负载间连线的压降。因为这受限于一定水平，建议按照输出电流选择适当直径的连线，以将压降减到最小。感测输入端位于产品前板，Sense端子上，请按正确极性连线到此。电源会自动检测外部感应端，并通过负载的实际电压而非输出电压，来补偿输出电压，从而按照电源与负载间的压降值提升输出电压。

最大补偿值：见“2.2 各产品型号详细规格”。



图 9

10.2 连接不同类型的负载

不同类型的负载，如阻性负载（台灯，电阻），电子负载或感性负载（马达），性能不同，它们会对电源起反作用。例如，马达会产生一反电压，导致电源因过压保护而关断输出。

电子负载有电压、电流和功率调整电路，它们与电源的相互作用，可能会提高输出纹波或其它多余的副作用。电阻负载几乎100%中性。故建议在连接应用设备时要考虑负载的特性。

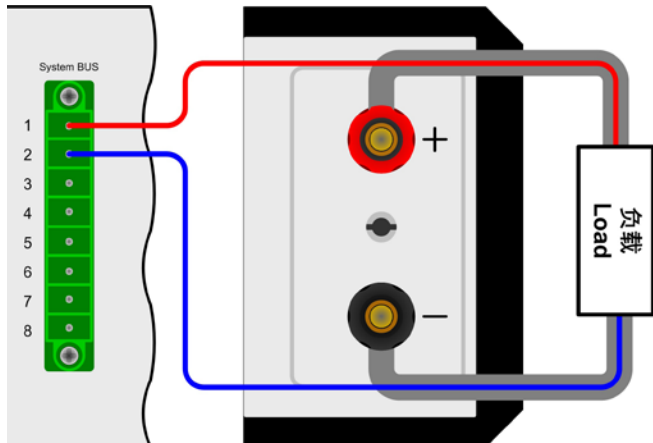
10.3 市电出现欠压或过压

本产品的特征为采用主动式功率因素和宽范围的输入。意为，可在90V...264V，3kW型号为180V...264V，输入电压下操作。90V或180V以下的输入电压被认为是断电，或完全关闭产品，它会保存产品最后条件，并关断功率输出。

应避免输入端长期欠压或过压！

重要！ 1500W功率的产品在输入电压低于约150V时降额至1000W。3000W功率的产品在输入电压低于约205V时降额至2000W。

10.4 系统总线端的功能

8脚System Bus端子位于产品后端，用来连接远程感测线或串联或并联多台产品。

各引脚分布说明：

- 1: 感测 +
- 2: 感测 -
- 3: 主机输出电流
- 4: 主机输出电压
- 5: 辅机输入电流
- 6: 辅机输入电压
- 7: 共享总线
- 8: 地

注意！3-8引脚的功能如下面段落描述，仅针对输出功率为1000W以上的产品才有，除720V产品外。

10.4.1 主机-辅机模式下的串联

注意：720V产品无该功能。

注意：额定功率以上的产品方具有该功能。

串联时，建议只针对具有相同输出电流的产品，否则额定输出电流最低的产品将定义为系统的最大电流。

一台设备总是下一台的主机，然后这个下一台成为辅机和再下一台的主机，如此类推。连接两台以上产品时，建议将某一台作为主机，其它为辅机。辅机由主机通过System Bus端字的辅机输入引脚3和4来控制。可同时控制其电压和电流，也可分开控制。

图10为连线举例。由主机提供电压和电流。如果只控制电压或电流其中一个，那另外一个的设定值应设为100%。

要远程控制整个系统，经模拟或数字接口控制主机即可。读出实际值时，电流监控值会代表整个系统的电流，但是电压监控值仅代表主机的输出电压。若想获得实际读数，可将串联（只有当所有产品为同型号时适用）在一起的多台产品的实际电压相乘，或者分开读出它们。

注意！如果将其中一输出极接地，为安全起见，建议具最低电位的极接地，也就是主机的负输出极(-)。

注意！系统主机必须始终是带最低电位的那台！

鉴于安全和隔离的原因，串联时需考虑下面一些限制和规则：

- 串联时任何一台产品的负直流输出端对地(PE)的电压不可上升到 >300V的电位！
- 共享总线端不可连线！
- 串联中各产品模拟接口的地(AGND, DGND)不可相互连接！
- 远程感测端不可连线！

举例：额定电压为360V的两台同型号产品，比如：PSI 8360-15 2U。按计算，它们串联后的总电压可能高达 720V。鉴于产品负输出端的电位，第二台产品的负直流端电压可能会上升到 360V。这是绝对不允许的！所以必须将较低电位的产品限制到某一最大值。下图阐述了最后形成的总电压将为660V。



图 10. 主-从模式下的串联

10.4.2 共享总线模式下的并联

注意：额定功率1kW以上的产品方具有该功能。

注意！只有相同型号（输出电压和电流相同）的产品才可用于下列操作模式。

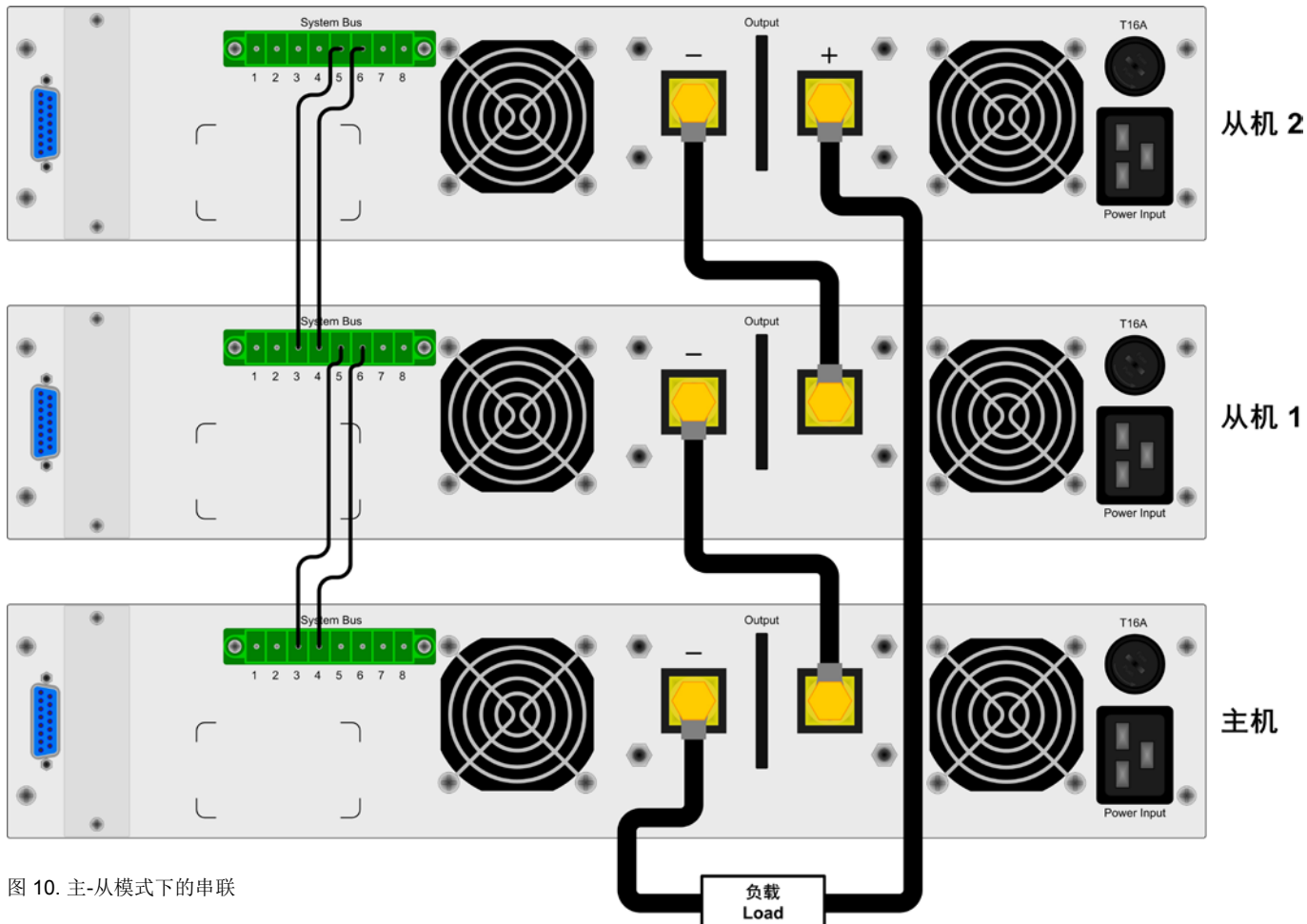
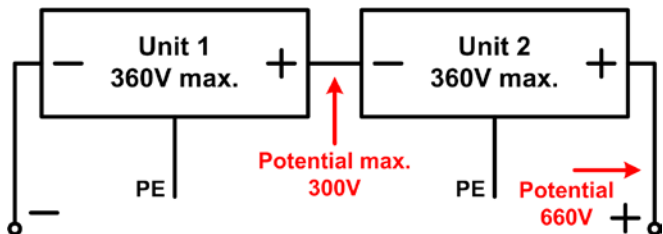
若想增加输出电流，可并联两台或更多同型号的产品。必须总是确保负载连线具有足够大的直径！理想情况下，连到负载的所有连线应该具有相同长度和直径。

需要进行下列连接：将所有产品的(+)直流输出极相互连接。所有产品**System Bus**端子的7（共享总线）和8（地）引脚并联连接。如果还需远程感测，则将所有感测+和感测-的输入脚并联后与负载连接。

重点：在该模式下，带**最低**输出电压的产品控制并决定整个并联系统的输出电压。意思是，该系统内的任何一台产品都可能成为这个任务的担当者。故建议挑选一台产品来控制整个系统的电压和电流，而将其他剩余产品的设定电压设为需求最小值。也可将所有辅机的电压和功率设定值设为100%，或者如果不需要，也可将每台机都设为同一值，从而可形成所需总数值。

所有产品显示各自实际数值，不会出现系统输出电流的总值。

要远程控制整个系统，经模拟或数字接口控制主机即可。读出实际值时，电压监控值会代表整个系统的电压，但是电流监控值仅代表主机的输出电流。若想获得实际读数，可将并联（只有具有相同输出电流的产品适用）在一起的多台产品的实际电流相乘，或者分开读出它们。

图11为连线举例。

10.4.3 混合连接

本产品允许一个系统内并联与串联的混合连接。虽然具有这功能，仍建议按下列步骤进行：

先执行并联，如：3台65V/10A的先并联，然后再将它们串联（相同的三台设备），以获得130V/30A的系统。

如需大电流，而且设备台数为奇数时，建议将负载放在并联产品的中间。

建议连接方式

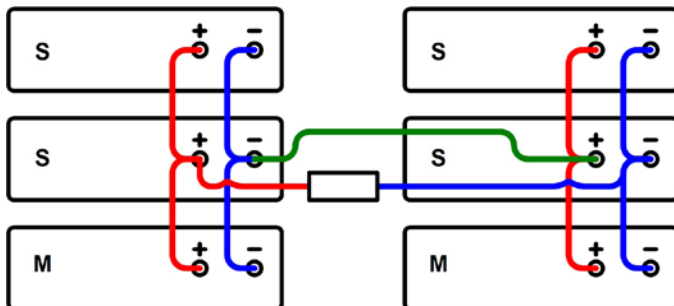

不建议连接方式



图11. 用共享总线下的并联

10.5 连网

下图描述了多台产品在数控状态下以星形（USB，RS232，Ethernet）或车形（CAN，GPIB）配置的连网举例。适用总线系统和接口的限制和技术规格。

通过**USB**，一台电脑可控制多达30台产品，需使用带特制电源的USB集线器。这也基本适用于RS232。区别在于操作和线长。

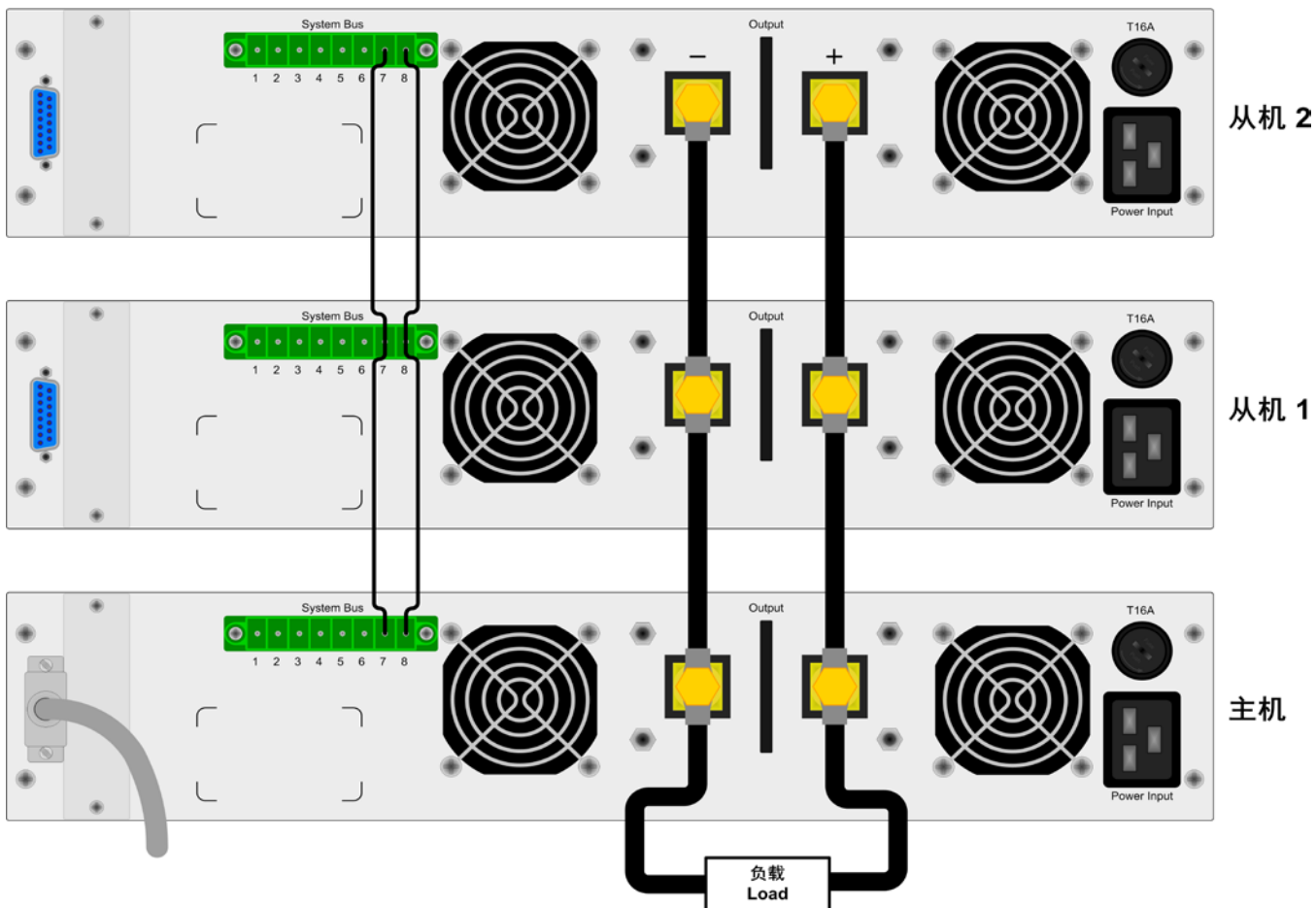
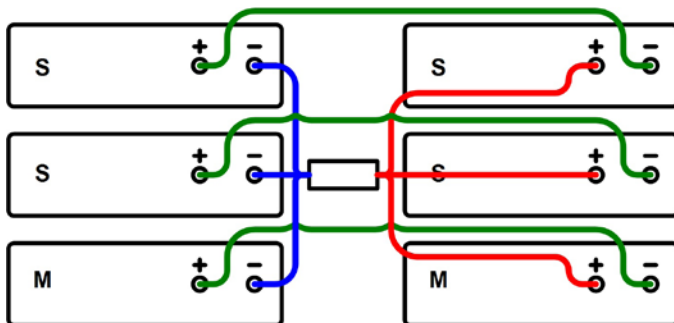
通过**CAN**，每个地址段上的多达30台电源，可容入新的或现有的CAN总线系统。它们由产品节点和RID组成。

通过**GPIB**，每一条总线限制最多为15台，由一台GPIB主机控制。一台电脑上可安装多台主机，这样可增加可编址单元数。



图 12. 用USB或RS232联网

10.6 其它附件和选项功能

可供下列附件：

a) USB-至-模拟接口UTA12

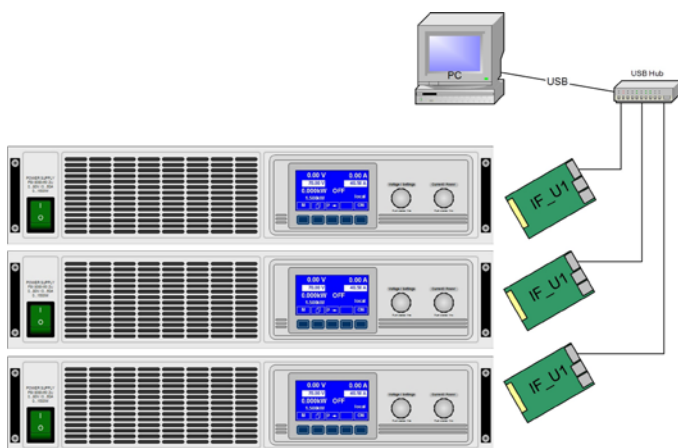
经USB(电脑面)和产品内置模拟接口远程控制。

b) IF选项卡：数字接口卡

还配USB，RS232，CAN，GPIB/IEEE(仅SCPI)，以太网/LAN或Profibus用可插拔式数字接口卡。

c) IF选项卡：模拟接口卡

还配扩展型、25针隔离模拟接口卡。可随时拆卸和安装。

可供下列选项：

a) HS选项功能：高速跃变(1kW以上型号)

通过减少输出电容容量来增加输出电压的动态。必须指出的是其它相关输出值也增加！

注意：这是个永久性更改，不可更改回来。

b) ZH选项功能：带汽车点火序列的内置有源负载

这个内部模块也被称为两象限模块，供应高达100W的连续功率和约2400W的峰值功率。主要目的是给产品的输出电容快速放电，比平常要快。从而增加输出电压的动态动作，但不影响其它输出值的。第二个功能是模拟内置汽车点火序列，从而可通过一按钮或远程信号触发它。该功能最初用在汽车行业，可用一开关停止该模块的功能。

注意：只有额定电压在360V以下的型号才有此功能。

c) IR选项功能：内阻调整

该选项可以后购买，并在产品设置菜单下用代码解锁。

解锁后，用户可选择U//P或U//R操作。在U//R模式下不可调节功率设定值，只能在产品设置下定义极限。

注意：在解锁这个选项前，最终需要更新产品固件。请咨询您的供货商！

10.7 固件更新

只有当产品出现错误行为或者应用新功能时才需进行产品固件更新。

要更新一台产品固件，需要用到某一数字接口卡，新的固件文档，称作“更新工具”的Windows软件。

下列这些接口卡才能用于固件更新：

- IF-U1 (USB)
- IF-R1 (RS232)
- IF-E1 (Ethernet/USB)
- IF-PB1 (Profibus/USB)

如果手上没有一张上述接口卡，则不可更新。请立即联系您的产品销售方寻求解决方案。

产品对应的更新工具和固件文档可从产品制造商网站获取，或者发邮件索取。更新工具将会指导用户整个半自动更新过程。



图 13. 用CAN卡联网举例，也适用于GPIB卡

© Elektro-Automatik

Reprint, duplication or partly, wrong use of this user instruction manual are prohibited and might be followed by legal consequences.

Safety instructions

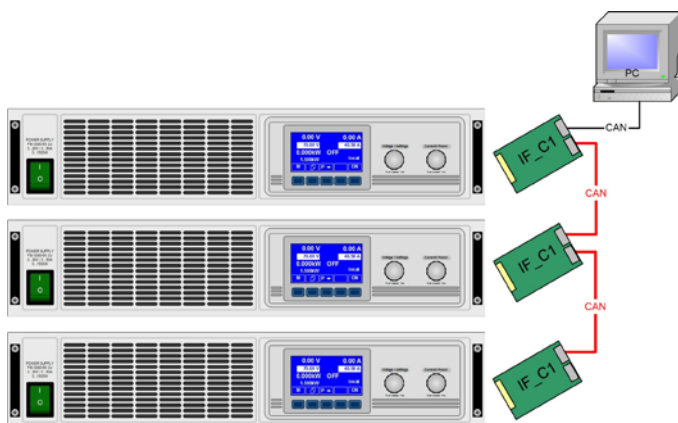

Dangerous voltage

Caution: The output voltage can rise to dangerous levels (> 60 VDC)!

All live parts have to be covered. All actions at the output terminals have to be done while the unit is switched off from the mains (mains switch OFF) and may only be executed by personnel which is instructed about the hazards of electrical current. Any connection between the load and the unit (at the output terminals) have to be scoop-proof. Applications connected to the power output must be configured and fused in a way that prevents the use of these to cause a damage or worse to the unit by overload or malfunction.



Important! Keep in mind!

- Only operate the unit at the voltage stipulated on the type plate
- Never insert mechanical parts, especially from metal, into the unit, there is risk of an electrical shock and the unit might get damaged
- Avoid the use or presence of liquids in the proximity of the unit, the liquid might get into the unit and cause damage
- Never touch the contacts of the mains plug at the mains cord directly after unplugging it from the mains socket, because there is risk of an electrical shock
- Never connect loads, especially ones with low resistance, to the unit while the power output is switched on, because it can cause sparks which might damage the unit and injure the hands
- In order to equip interface cards into the slots on rear, the common ESD regulations have to be followed
- The interface card may only be plugged and unplugged while the unit is completely switched off (mains switch OFF)
- Aging of the device, as well heavy use may result in unpredictable behaviour of control elements like pushbuttons and rotary knobs.

	Page
1. Introduction	36
2. Technical specifications.....	36
2.1 Control panel	36
2.2 Model specific data.....	37
3. Device description.....	39
3.1 Views.....	39
3.2 Scope of delivery.....	40
4. General	41
4.1 Prologue / Warning.....	41
4.2 Cooling	41
4.3 Opening the device.....	41
5. Installation.....	41
5.1 Visual check	41
5.2 Mains connection 2U models	41
5.3 Mains connection 4U models	41
5.4 DC output terminal.....	41
5.5 Terminal „Sense“ (Remote sense)	41
5.6 Interface card slot.....	41
6. Handling.....	42
6.1 The display	42
6.2 Used symbols	42
6.3 Short overview about the display elements.....	42
6.4 Switching the unit on	43
6.5 Switching the power output on	43
6.6 Adjusting set values.....	44
6.7 Switching the button panel	44
6.8 Locking the control panel.....	44
6.9 Changing the location mode.....	44
6.10 Switching to the function manager	45
6.11 Activating the menu	45
6.12 Parameter pages	45
6.13 Alarms, warnings and signals.....	45
6.14 Acknowledging alarms and warnings	46
6.15 The function manager.....	46
6.15.1 Configuring the function	47
6.15.2 The function layout	47
6.15.3 Configuring sequences.....	47
6.15.4 Sequence related parameters	47
6.15.5 Defining the sequence points	47
6.15.6 Display during the function run	48
6.15.7 Controlling the function manager.....	48
7. Device configuration.....	49
7.1 Defining operation parameters	50
7.2 Predefining preset lists	50
7.3 Adjustment limits	51
7.4 Configuring the control panel.....	51
7.5 Configuring the graphic display	52
7.6 Supervision.....	52
7.6.1 Voltage supervision	52
7.6.2 Current supervision	53
7.6.3 Step response supervision	54
7.7 Reset to default configuration.....	55
7.8 Unlocking the U//R operation mode.....	55
7.9 Locking the device configuration	55
8. Digital interfaces.....	56
8.1 General.....	56
8.2 Configuring the interface cards.....	56

	Page
9. Internal analogue interface.....	56
9.1 General.....	56
9.2 Settings for the analogue interface.....	56
9.3 Example applications.....	58
10. Other applications.....	59
10.1 Remote sense.....	59
10.2 Connecting different types of loads.....	59
10.3 Mains undervoltage or overvoltage occurs.....	59
10.4 Functions of terminal System Bus.....	59
10.4.1 Series connection in Master-Slave mode.....	59
10.4.2 Parallel connection in Share Bus mode.....	60
10.4.3 Mixed connections.....	61
10.5 Networking.....	62
10.6 Accessories and options.....	62
10.7 Firmware update.....	62

1. Introduction

The laboratory power supplies of the series **PSI 8000 2U** are ideally suited for test systems and industrial control facilities by their 19" draw-out case.

Apart from standard functions of power supplies the user can define and recall different presets of set values, supervise set values and actual values by definable limits or create function runs of configurable preset values with the integrated function manager.

The devices also feature an integrated analogue interface that can handle the common voltage ranges of 0...5V or 0...10V. This offers a way of easily monitoring the device as well as total remote control. The logical levels of the digital inputs and the output can be modified.

The optionally available, digital interface cards provide an even wider spectrum of control and monitoring functions by means of a PC. Another optionally available extension card is the galvanically isolated analogue interface IF-A1 which can even better serve to control the device by external means, like a PLC, as the internal interface.

The integration into existent systems is done very comfortably by using an interface card, while there is no need to configure the card at all or with only a few settings.

Via the analogue interface, the power supply can also be operated in connection to other power supply units, controlling these via the interface. Or they can be controlled and monitored by an external control system, like a PLC.

Most models from 1000W feature an adjustable power regulation circuit (with two exceptions, see technical specs), as well as a „System Bus“ terminal which enables series connection as master-slave or parallel connection with share bus.

The main functions at a glance:

- Set voltage and current, each with 0...100%
- Adjustable overvoltage threshold 0...110% UNom
- Pluggable interface cards (CAN, USB, RS232, IEEE/GPIB, Analogue, Ethernet/LAN, Profibus)
- Analogue interface for external control and monitoring with 0...5V or 0...10V (selectable) for 0...100%
- Powers of 640W, 1000W, 1500W and 3000W
- Temperature controlled fan
- Status indication (OT, OV, CC, CV) in the display
- 4 selectable memory sets, supervision function
- Function manager
- Adjustable internal resistance (optional)
- High speed ramping (optional)
- Internal, active load with car ignition sequence (optional)
- Master-slave series connection (models from 1kW)
- Parallel connection (Share bus)

2. Technical specifications

2.1 Control panel

Type

Display	Graphics display 128x64 dots
Operating controls:	6 pushbuttons, 2 rotary knobs

Displayed formats

The nominal values limit the maximum adjustable range.

Actual values and set values for voltage, current and power (models from 1kW) are displayed simultaneously, the set value of the overvoltage threshold is displayed separately.

Display of voltage values

Resolution:	4 digits
Formats:	0.00V...99.99V 100.0...999.9V

Display of current values

Resolution:	4 digits
Formats:	0.000A...9.999A 0.00A...99.99A

Display of power values

Resolution:	4 digits
Formats:	0.0W...999.9W 0.000kW...9.999kW

Display of resistance values

(only with unlocked option „internal resistance control“)

Resolution:	4 digits
Formats:	00.00mΩ...99.99mΩ 0.000Ω...9.999Ω 00.00Ω...99.99Ω

Time displays

Times are displayed in 4 automatically switched ranges.

Resolution:	
Range 1:	2ms to 9.999 s
Range 2:	10ms to 59.99s
Range 3:	1:00m to 59:59min
Range 4:	1:00h to 99:59h

Accuracy:

Range 1:	2ms
Range 2:	10ms
Range 3:	1s
Range 4:	1 min

2.2 Model specific data

	PSI 8032-20 2U	PSI 8065-10 2U	PSI 8160-04 2U	PSI 8080-40 2U	PSI 8040-60 2U	PSI 8080-60 2U
Mains input						
Input voltage	90...264V	90...264V	90...264V	90...264V	90...264V	90...264V
- with derating	-	-	-	-	90...150V	90...150V
Input current at 230V	max. 3.2A	max. 3.4A	max. 3.2A	max. 4.8A	max. 7.5A	max. 7.5A
Input frequency	45...65Hz	45...65Hz	45...65Hz	45...65Hz	45...65Hz	45...65Hz
Input fuse	T 8A	T 8A	T 8A	T 16A	T 16A	T 16A
Power factor	> 0.99	> 0.99	> 0.99	> 0.99	> 0.99	> 0.99
Output - Voltage						
Nominal voltage U_{Nom}	32V	65V	160V	80V	40V	80V
Adjustable range	0V... U_{Nom}	0V... U_{Nom}	0V... U_{Nom}	0V... U_{Nom}	0V... U_{Nom}	0V... U_{Nom}
Stability at mains fluctuation $\pm 10\% \Delta U_{IN}$	< 0.02%	< 0.02%	< 0.02%	< 0.02%	< 0.02%	< 0.02%
Stability at 10...90% load	< 0.05%	< 0.05%	< 0.05%	< 0.05%	< 0.05%	< 0.05%
Ripple P-P	< 100mV	< 150mV	< 120mV	< 10mV	< 10mV	< 10mV
Ripple RMS	< 8mV	< 10mV	< 20mV	< 4mV	< 4mV	< 4mV
Accuracy*	$\leq 0.2\%$	$\leq 0.2\%$	$\leq 0.2\%$	$\leq 0.2\%$	$\leq 0.2\%$	$\leq 0.2\%$
Resolution of display	10mV	10mV	100mV	10mV	10mV	10mV
Remote sense compensation	max. 2.0V	max. 2.0V	max. 2.0V	max. 2.0V	max. 2.0V	max. 2.0V
Overvoltage protection (adjustable)	0...35.2V	0...71.5V	0...176V	0...88V	0...44V	0...88V
Output - Current						
Nominal current I_{Nom}	20A	10A	4A	40A	60A	60A
Adjustable range	0... I_{Nom}	0... I_{Nom}	0... I_{Nom}	0... I_{Nom}	0... I_{Nom}	0... I_{Nom}
Stability at mains fluctuation $\pm 10\% \Delta U_{IN}$	< 0.05%	< 0.05%	< 0.05%	< 0.05%	< 0.05%	< 0.05%
Stability at 0...100% ΔU_{OUT}	< 0.15%	< 0.15%	< 0.15%	< 0.15%	< 0.15%	< 0.15%
Ripple P-P	< 65mA	< 25mA	< 3mA	< 19mA	< 100mA	< 100mA
Ripple RMS	< 10mA	< 3mA	< 1mA	< 7mA	< 7mA	< 7mA
Accuracy*	$\leq 0.2\%$	$\leq 0.2\%$	$\leq 0.2\%$	$\leq 0.2\%$	$\leq 0.2\%$	$\leq 0.2\%$
Resolution of display	10mA	10mA	1mA	10mA	10mA	10mA
Transient recovery time 10...90% load	< 2ms	< 2ms	< 2ms	< 2ms	< 2ms	< 2ms
Output - Power						
Nominal power P_{Nom}	640W	650W	640W	1000W	1500W	1500W
Nominal power at derating	-	-	-	-	1000W	1000W
Accuracy*	-	-	-	0... P_{Nom}	0... P_{Nom}	0... P_{Nom}
Adjustable range	-	-	-	$\leq 0.2\%$	$\leq 0.2\%$	$\leq 0.2\%$
Resolution of display	0.1W	0.1W	0.1W	1W	1W	1W
Miscellaneous						
Efficiency	90.5%	93.0%	93.0%	90.5%	90.5%	90.5%
Ambient temperature	0...40°C	0...40°C	0...40°C	0...40°C	0...40°C	0...40°C
Storage temperature	-20...70°C	-20...70°C	-20...70°C	-20...70°C	-20...70°C	-20...70°C
Humidity rel.	< 80%	< 80%	< 80%	< 80%	< 80%	< 80%
Dimensions (WxHxD) standard model	19" 2U 380mm	19" 2U 380mm	19" 2U 380mm	19" 2U 460mm	19" 2U 460mm	19" 2U 460mm
Dimensions (WxHxD) option ZH	19" 2U 380mm	19" 2U 380mm	19" 2U 380mm	19" 2U 460mm	19" 2U 460mm	19" 2U 460mm
Weight standard model	9.5kg	9.5kg	9.5kg	13.5kg	13.5kg	13.5kg
Weight with option ZH	11kg	11kg	11kg	15kg	15kg	15kg
Isolation output to enclosure	500V DC	500V DC	500V DC	500V DC	500V DC	500V DC
Isolation input to output	4200V DC					
Cooling	by fans, air inlet on the front, air exhaust on the rear					
Safety	EN 60950					
EMC standards	EN 61326, EN 55022 Class B					
Overvoltage class	2					
Protection class	1					
Pollution degree	2					
Operational altitude	<2000m					
Series operation						
max. series connection voltage	600V					
Master-Slave	no					
Parallel operation						
max. parallel connection voltage	720V					
Master-Slave	yes, via Share bus					
Analogue programming						
Input range	0...5V or 0...10V, selectable					
Accuracy	$\leq 0.2\%$					
Input impedance	53kOhm					
Article number	09230417	09230418	09230419	09230410	09230425	09230411

* Related to the nominal value, the accuracy defines the maximum allowed deviation between set value and actual value.

Example: a 80V model has min. 0.2% voltage accuracy. This is 160mV. When setting a voltage of 5V and with an allowed maximum deviation of 160mV, the resulting actual value could be between 4.84V and 5.16V.

	PSI 8360-15 2U	PSI 8040-120 2U	PSI 8080-120 2U	PSI 8160-60 2U	PSI 8360-30 2U	PSI 8720-15 2U
Mains input						
Input voltage	90...264V	180...264V	180...264V	180...264V	180...264V	180...264V
- with derating	90...150V	180...207V	180...207V	180...207V	180...207V	180...207V
Input current at 230V	max. 7.5A	max. 15A	max. 15A	max. 15A	max. 15A	max. 15A
Input frequency	45...65Hz	45...65Hz	45...65Hz	45...65Hz	45...65Hz	45...65Hz
Input fuse (standard model)	T 16A	T 16A	T 16A	T 16A	T 16A	T 16A
Input fuse (model with option ZH)	T 16A	2x T16A	2x T16A	2x T16A	2x T16A	-
Power factor	> 0.99	> 0.99	> 0.99	> 0.99	> 0.99	> 0.99
Output - Voltage						
Nominal voltage U_{Nom}	360V	40V	80V	160V	360V	720V
Adjustable range	0V... U_{Nom}	0V... U_{Nom}	0V... U_{Nom}	0V... U_{Nom}	0V... U_{Nom}	0V... U_{Nom}
Stability at mains fluctuation $\pm 10\% \Delta U_{IN}$	< 0.02%	< 0.02%	< 0.02%	< 0.02%	< 0.02%	< 0.02%
Stability at 10...90% load	< 0.05%	< 0.05%	< 0.05%	< 0.05%	< 0.05%	< 0.05%
Ripple P-P	< 50mV	< 10mV	< 10mV	< 20mV	< 30mV	< 50mV
Ripple RMS	< 8mV	< 5mV	< 5mV	< 10mV	< 12mV	< 20mV
Accuracy*	$\leq 0.2\%$	$\leq 0.2\%$	$\leq 0.2\%$	$\leq 0.2\%$	$\leq 0.2\%$	$\leq 0.2\%$
Resolution of display	100mV	100mV	100mV	100mV	100mV	100mV
Remote sense compensation	max. 2.0V	max. 2.0V	max. 2.0V	max. 2.0V	max. 2.0V	max. 2.0V
Overvoltage protection (adjustable)	0...396V	0...44V	0...88V	0...176V	0...396V	0...792V
Output - Current						
Nominal current I_{Nom}	15A	120A	120A	60A	30A	15A
Adjustable range	0... I_{Nom}	0... I_{Nom}	0... I_{Nom}	0... I_{Nom}	0... I_{Nom}	0... I_{Nom}
Stability at mains fluctuation $\pm 10\% \Delta U_{IN}$	< 0.05%	< 0.05%	< 0.05%	< 0.05%	< 0.05%	< 0.05%
Stability at 0...100% ΔU_{OUT}	< 0.15%	< 0.15%	< 0.15%	< 0.15%	< 0.15%	< 0.15%
Ripple P-P	< 1mA	< 25mA	< 25mA	< 18mA	< 60mA	< 2mA
Ripple RMS	< 0.45mA	< 9mA	< 9mA	< 6mA	< 21mA	< 1mA
Accuracy*	$\leq 0.2\%$	$\leq 0.2\%$	$\leq 0.2\%$	$\leq 0.2\%$	$\leq 0.2\%$	$\leq 0.2\%$
Resolution of display	10mA	100mA	100mA	10mA	10mA	10mA
Transient recovery time 10...90% load	< 2ms	< 2ms	< 2ms	< 2ms	< 2ms	< 2ms
Output - Power						
Nominal power P_{Nom}	1500W	3000W	3000W	3000W	3000W	3000W
Nominal power at derating	1000W	2500W	2500W	2500W	2500W	2500W
Accuracy*	0... P_{Nom}	0... P_{Nom}	0... P_{Nom}	0... P_{Nom}	0... P_{Nom}	0... P_{Nom}
Adjustable range	$\leq 0.2\%$	$\leq 0.2\%$	$\leq 0.2\%$	$\leq 0.2\%$	$\leq 0.2\%$	$\leq 0.2\%$
Resolution of display	1W	1W	1W	1W	1W	1W
Miscellaneous						
Efficiency	93.0%	90.5%	90.5%	93.0%	90.5%	90.5%
Ambient temperature	0...40°C	0...40°C	0...40°C	0...40°C	0...40°C	0...40°C
Storage temperature	-20...70°C	-20...70°C	-20...70°C	-20...70°C	-20...70°C	-20...70°C
Humidity rel.	< 80%	< 80%	< 80%	< 80%	< 80%	< 80%
Dimensions (WxHxD) standard model	19" 2U 460mm	19" 2U 460mm	19" 2U 460mm	19" 2U 460mm	19" 2U 460mm	19" 2U 460mm
Dimensions (WxHxD) option ZH	19" 2U 460mm	19" 4U 460mm	19" 4U 460mm	19" 4U 460mm	19" 4U 460mm	-
Weight standard model	13.5kg	16.5kg	16.5kg	16.5kg	16.5kg	16.5kg
Weight with option ZH	15kg	19.5kg	19.5kg	19.5kg	19.5kg	-
Isolation output to enclosure	500V DC	500V DC	500V DC	500V DC	500V DC	1000V DC
Isolation input to output	4200V DC					
Cooling	by fans, air inlet on the front, air exhaust on the rear					
Safety	EN 60950					
EMC standards	EN 61326, EN 55022 Class B					
Overvoltage class	2					
Protection class	1					
Pollution degree	2					
Operational altitude	<2000m					
Series operation						
max. series connection voltage	600V					
Master-Slave	no					
Parallel operation						
max. parallel connection voltage	720V					
Master-Slave	yes, via Share bus					
Analogue programming						
Input range	0...5V or 0...10V, selectable					
Accuracy	$\leq 0.2\%$					
Input impedance	53kOhm					
Article number	09230414	09230426	09230412	09230413	09230415	09230416

* Related to the nominal value, the accuracy defines the maximum allowed deviation between set value and actual value.

Example: a 80V model has min. 0.2% voltage accuracy. This is 160mV. When setting a voltage of 5V and with an allowed maximum deviation of 160mV, the resulting actual value could be between 4.84V and 5.16V.

3. Device description

3.1 Views

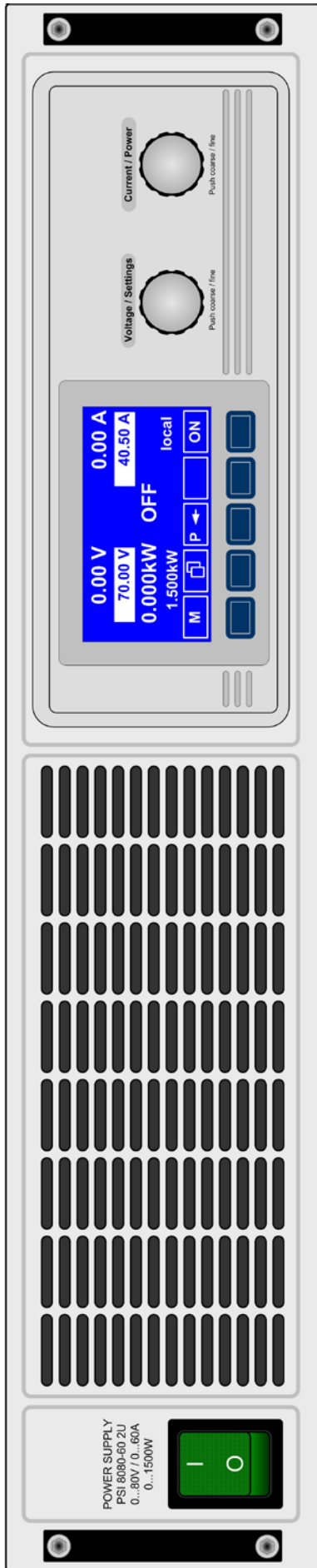

Figure 1. Front view 2U standard version, models with ZH option differ

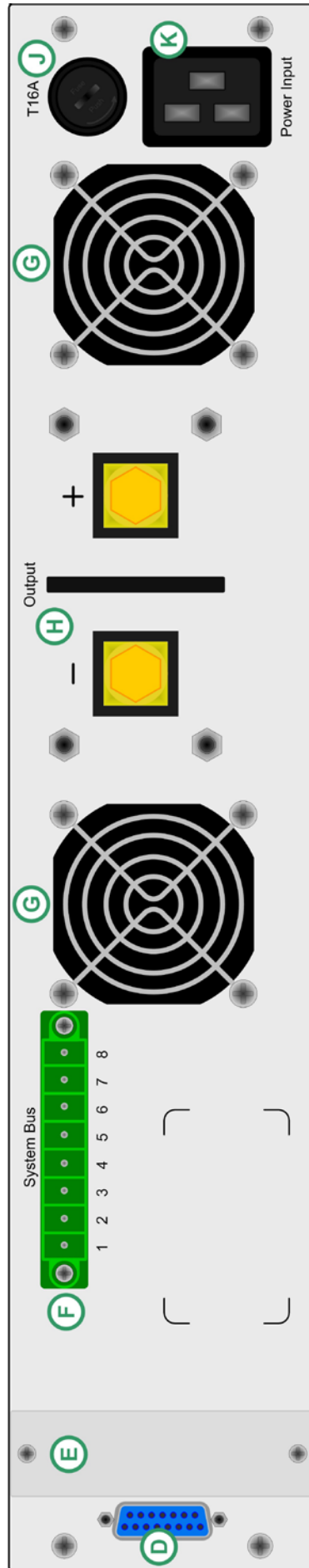

Figure 2. Rear view 2U version

Pin assignment of System Bus (see section 10.4 for details):

- 1 - Sense +
- 2 - Sense -
- 3 - Master output Current
- 4 - Master output Voltage
- 5 - Slave input Current
- 6 - Slave input Voltage
- 7 - Share Bus
- 8 - Ground

- Legend:
- A - Power switch
 - B - Air ventilation slots
 - C - Control panel
 - D - Analogue interface, 15pole, female
 - E - Slot for digital extension cards
 - F - System Bus
 - G - Fans
 - H - Power output, M8 screw block
 - J - Input fuse (for value see „2. Technical specifications“)
 - K - Power input socket, 3pole, IEC 60320 (see section 5.2)

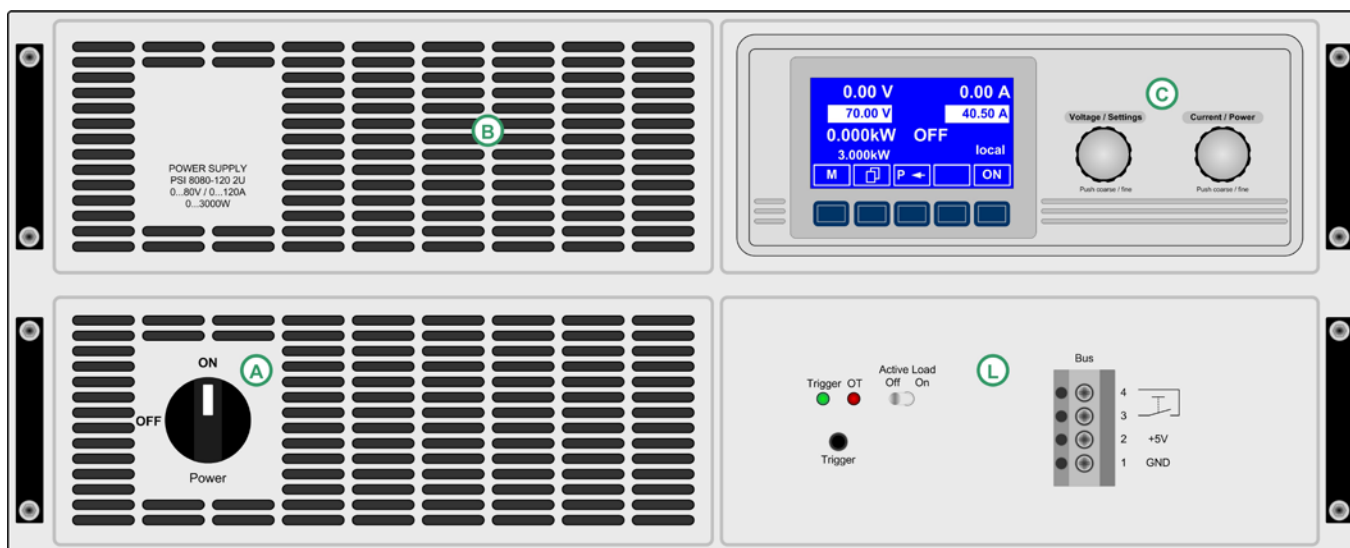

Figure 3. Front view 4U version with ZH option

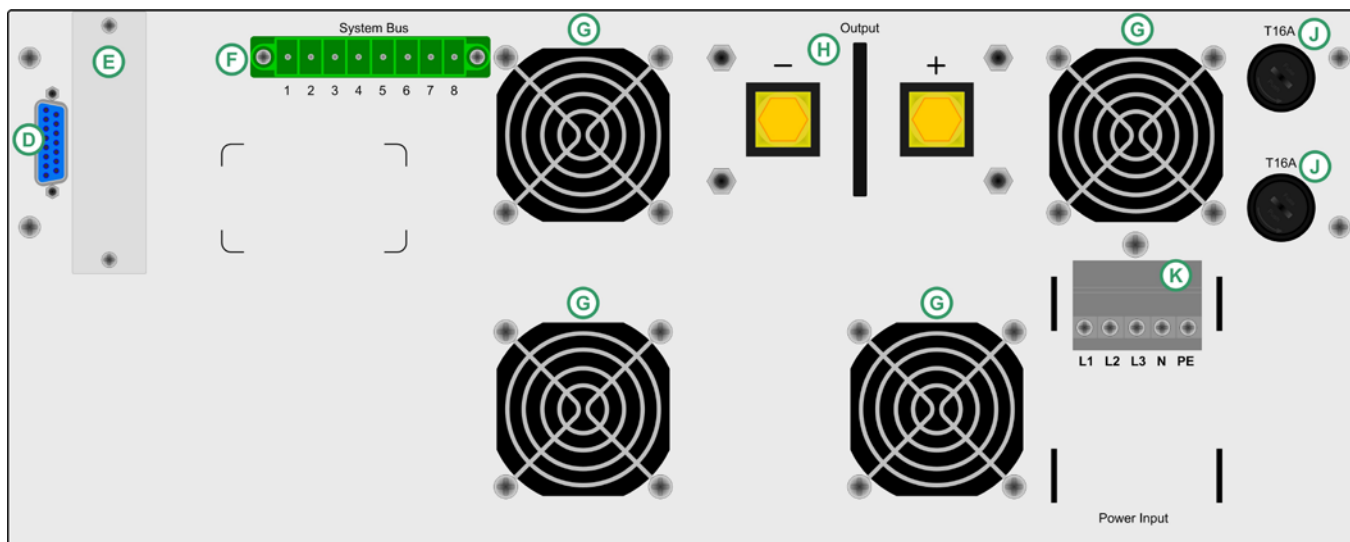

Figure 4. Rear view 4U version

Legend:

- A - Power switch
- B - Air ventilation slots
- C - Control panel
- D - Analogue interface, 15pole, female
- E - Slot for digital extension cards
- F - System Bus
- G - Fans
- H - Power output, M8 screw block
- J - Input fuses (for value see „2. Technical specifications“)
- K - Power input terminal (see section 5.3)
- L - Control panel of ZH option

Pin assignment of System Bus (see section 10.4 for details):

- 1 - Sense +
- 2 - Sense -
- 3 - Master output Current
- 4 - Master output Voltage
- 5 - Slave input Current
- 6 - Slave input Voltage
- 7 - Share Bus
- 8 - Ground

3.2 Scope of delivery

- 1 x Power supply unit
- 1 x Printed user manual
- 1 x Mains cord (2U models only)

4. General

4.1 Prologue / Warning

This user instruction manual and the device are intended to be used by users who know about the principle of a power supply. The handling of the device should not be left to persons who are unaware of the basic terms of electrotechnology, because these are not described in this manual. Inappropriate handling and non-observance to the safety instructions may lead to a damage of the device or loss of warranty!

4.2 Cooling

The air inlets in the front and the air outlets at the rear have to be kept clean to ensure proper cooling. Take care of at least 10cm distance at the rear to any surrounding objects in order to guarantee unimpeded air flow.

4.3 Opening the device

When opening the unit or removing parts from the inside with tools there is risk of electric shock by dangerous voltages. Open the unit only at your own risk and disconnect it from the mains before.

Any servicing or repair may only be carried out by trained personnel, which is instructed about the hazards of electrical current.

5. Installation

5.1 Visual check

After receipt, the unit has to be checked for signs of physical damage. If any damage is found, the unit may not be operated. Also contact your dealer immediately.

5.2 Mains connection 2U models

The unit is grounded via the mains cord. Thus the unit may only be operated at a mains socket with grounding contact. This must not be interrupted by an extension cable without ground conductor!

The unit is fused with a 5 x 20mm safety fuse (for value see technical specs table), which is located in the fuseholder at the rear.

5.3 Mains connection 4U models

Though the device features a three-phase input terminal, it is used with a normal 230V supply (L + N + PE). Three-phase input is not allowed because of security reasons. The input uses L1 and L2, plus N and PE. So the input connection has to be like this:

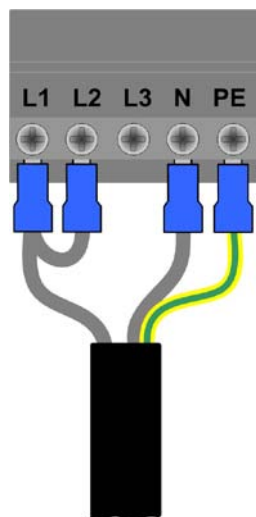

5.4 DC output terminal

The power output is located on the front of the device. It is permanent short-circuit-proof.

The output is **not** fused! In order to avoid damage to the load application, always take care for the nominal values of the load.

The cross section of the leads depends on several conditions, like the output current, the lead length and the ambient temperature.

Up to 1.5m lead length we recommend to use:

up to 10A :	0,75mm ²	up to 15A :	1,5mm ²
up to 30A :	4mm ²	up to 40A :	6mm ²
up to 60A :	16mm ²	up to 120A :	35mm ²

per cable (flexible wire).

The outputs “+” and “-” are not grounded, so that **one** of them may be grounded if necessary.

Attention! When grounding one of the output poles always check if one of the poles of the load (eg. electronic load) is also grounded. This could result in a short-circuit!

Attention! Notice the potential shift of the output poles when using series connection! Grounding is hereby only recommended at the pole with the lowest potential against ground.

5.5 Terminal „Sense“ (Remote sense)

In order to compensate the voltage drop along the load leads (max. 1V per lead), the power supply can „sense“ the voltage at the load instead at the output. It will regulate the output voltage so that the desired voltage is provided to the load.

The remote sense feature is wired with correct polarity to the terminal **System Bus** at the rear.

(+) Sense must only be connected to (+) at the load application and (-) Sense must only be connected to (-)! Else both systems can take damage.

For additional information also see section „10.1 Remote sense“.

5.6 Interface card slot

The unit can be equipped with an optional interface card. The slot to insert the card is located at the rear side. Further information about the interface cards can be found in section „8. Digital interfaces“.

6. Handling

6.1 The display

Figure 5 shows an overview of the graphical display. During normal operation, the display shows the actual and set values of voltage (upper left), current (upper right) and power (lower left). In device setup mode, it display parameters and settings.

The power set value is only displayed at models from 1kW which feature power regulation.

In case the optional „internal resistance control“ is unlocked, the power set value might be replaced by the internal resistance set value, depending on what is selected in the device setup.

6.2 Used symbols

In the following description the display and operating elements are marked differently by symbols.

 = **Displayed only**, all elements which are only displayed and which represent a state are marked with this symbol

 = **Parameter**, changeable values, are marked with this symbol and are emphasised

 = **Menu items**, selectable, lead to the next sublevel or to the bottom level with parameters

Brackets {...} mark possible options or adjustment ranges for parameters.

6.3 Short overview about the display elements

 **70.00 V** Actual value of the output voltage

 **35.00 A** Actual value of the output current

 **1.300kW** Actual value of the output power

During normal operation the actual values are displayed in big letters.

 **70.00 V** Set value of voltage

Target value of the desired output voltage (left knob). The value is adjusted in coarse (see section 6.6 for step widths) or fine (always rightmost digit). Switching between coarse and fine is done with the pushbuttons on the left rotary knob.

 **40.50 A** Set value of current

Target value of the desired output current (right knob). The value is adjusted in coarse (see section 6.6 for step widths) or fine (always rightmost digit). Switching between coarse and fine is done with the pushbuttons on the right rotary knob. It might be required to push button  before the set value is adjustable.

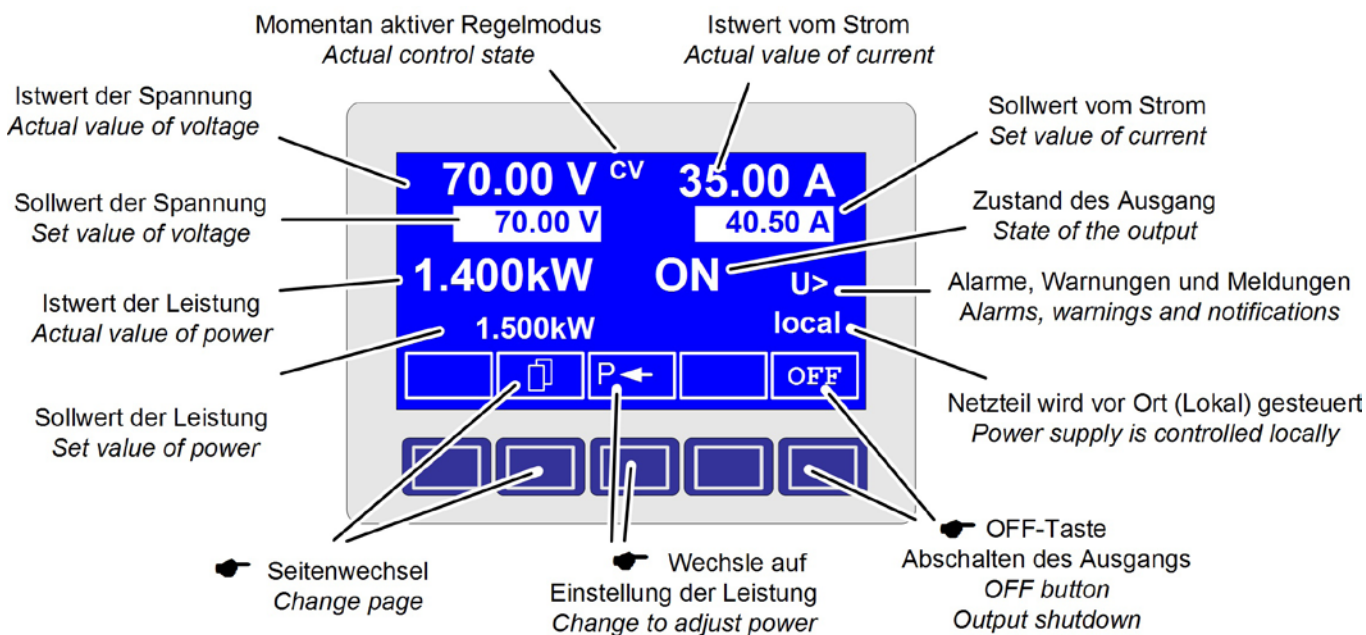







Figure 5

 **1.500kW** Set value of the power
 Target value of the desired maximum output power (right knob).
 In order to set the value, button  has to be pushed before.

 **10.00 Ω** Set value of internal resistance (optional)
 Target value of the desired internal resistance value (right knob).
 This set value replaces the power set value if the internal resistance control is unlocked and U/I/R mode has been selected in the device setup. In order to set the value, button  has to be pushed before.

The state of the power output is displayed in the bottom right corner of the display.

 **{ON,OFF}** State of the power output
 The currently active control mode is displayed to the right of the related actual values. For instance, the abbreviation „CV“ is displayed next to the actual value of voltage, because it means that „Constant voltage“ mode is active. The output values are limited by the active control mode:

 **CV** - limited by the voltage set value
 (= Constant Voltage)

 **CP** - limited by the power set values
 (= Constant Power)

 **CC** - limited by the set value of current
 (= Constant Current)

 **CR** - limited by the set value for internal resistance (optional at U/I/R mode), indicated next to the actual voltage
 (= Constant Resistance)

Additionally to the state of the output an alarm, a warning or a signal can be displayed:

 **Alarm** Example:  **OT** = Overtemperature

 **Warnings** Example:  **U>** = Overvoltage

 **Signals** Example:  **I>** = Overcurrent

The location from where the unit is currently controlled is displayed below the output state. This location is absolute, which means that you cannot control the unit from elsewhere without changing the location.

 **local** Control only possible at the unit

 **remote** Remote control via communication interfaces (IF-C1, IF-R1, IF-U1 etc.)

 **extern** Remote control via analogue interface

6.4 Switching the unit on

The unit is switched on with the mains switch. After it has been switched on, the displays shows the device type and, if programmed, a user text.

The user text can be entered via one of the digital interface cards using an included LabView VI. This text is intended to identify a single unit in an complex environment of multiple units.

After the internal system has been verified and has booted, the last state of the power supply (set values, alarm management etc.) is restored. The return state of the output after a mains loss (power fail error) or after the unit was switched on can be set in the  **Profile** menu.

6.5 Switching the power output on

 By pressing the **ON** button the power supply output is switched on, as long as it is not blocked by the input pin „REM-SB“ (13) of the internal analogue interface or input pin „Standby“ (11) of a equipped analogue interface card IF-A1, because both have higher priority. If one of these is preventing to switch the output on by the button, the display will indicate the status text „auto ON“, noticing the user that the output will switch on as soon as the block from the pins is removed.





Note: in local state (see section 6.9), the pin REM-SB of the analogue interface (internal or external) is inoperative.

The display shows the current state with „**ON**“.

 The **OFF** button switches the power supply output off (shutdown). This state is displayed with „**OFF**“.

6.6 Adjusting set values

As long as „extern“ or „remote“ are not shown in the display, the set values for voltage, current or power can be set manually.

The mode is selected in the device setup at  **Accept set value**. The setting can be accessed with  ->  Profile ->  General settings ->  Control panel. See „7.4 Configuring the control panel“ for details.

Direct setting of the set values

Using the rotary knobs directly sets the set values.

The left rotary knob adjusts the voltage. The set value of the voltage is displayed invertedly while it is selected and adjusted.

The right rotary knob either sets the set value for the current, for the power (at models from 1kW) or internal resistance (optional, unlockable, with U/I/R mode chosen). The selected set value is displayed invertedly.

With the select keys



the set value for the power, with



the set value for the internal resistance or with



the set value for the current is selected.

The maximum adjustable power can also be limited.

Set values are submitted

Alternatively to the direct adjustment of set values you can choose to set the set values only after submitting them with the **RETURN** button. See section „7. Device configuration“ for details. The set values can still be changed with the rotary knobs, but are not set to the output as long as they're not submitted. While the set value is unchanged, only its unit is displayed invertedly. If the set value is changed it is also displayed invertedly.

The **SELECT** keys switch from current adjustment to power adjustment for the right rotary knob. The chosen set values are not submitted to and set by the power supply until then.



Pressing the **RETURN** button submits the set values.



Pressing the **ESC** button discards the new set values and the old set values are displayed again.

Note: the adjustment of the resistance set value is only accessible after the optional „internal resistance control“ is unlocked (see section 7.8).

The resistance set value is adjustable from 0Ω up to 20* Unom/Inom. Means, for example, at a device with Unom = 65V and Inom = 10A it can be adjusted to a maximum of 130Ω.

Using predefined set values

A table of up to 4 sets of set values is accessible in the menu

 **Preset List** („7.2 Predefining preset lists“). The left knob selects the preset list and with the **RETURN** button the set is submitted or discarded with the **ESC** button.



The chosen set is still 1. After the **RETURN** button is pressed, the set values of set 3 are submitted to the power supply. The display then shows the new set values of set 3.

The  **MEMORY** button can be used to jump straight to the menu page where the preset lists are defined and there they're edited and submitted with **RETURN** as usual.

Step widths for set value adjustment

Voltage			Current		
Nom. val	Coarse	Fine	Nom. val	Coarse	Fine
32V	200mV	10mV	4A	50mA	1mA
40V	0.5V	10mV	5A	50mA	1mA
65V	0.5V	10mV	10A / 15A	0.1A	10mA
80V	0.5V	10mV	20A / 30A	0.2A	10mA
160V	1V	100mV	40A / 60A	0.5A	10mA
360V	2V	100mV	120A	1A	100mA
720V	5V	100mV			

Power			Resistance		
Nom. val	Coarse	Fine	Nom. value	Coarse	Fine
640/650W	5W	100mW	13.3/16Ω	100mΩ	10mΩ
1000W	10W	1W	26.7/32/40Ω	200mΩ	10mΩ
1500W	10W	1W	53.3/64Ω	500mΩ	10mΩ
3000W	20W	1W	130Ω	1Ω	10mΩ
			240/260Ω	2Ω	10mΩ
			480/720/800Ω	5Ω	10mΩ
			960Ω	10Ω	10mΩ

6.7 Switching the button panel



The button **PAGE** is used to switch to another button panel. The new button assignments of the other panel allow the user to lock the control panel, switch to the function manager or set the location mode.

6.8 Locking the control panel



The button „Lock button panel“ locks all buttons, except itself, and the rotary knobs. The unit is now locked from manual access, so that no set value can be changed or no menu is accessible. The locking mode can be set up in the menu. The control panel can be either completely inactive or it can exclude the **OFF** button (the unit is then locked but can be switched off and on by the **OFF** button). See also „Control panel lock“ in section „7.4 Configuring the control panel“.



After the control panel was locked it changes to this icon. The button can be used to unlock the control panel again, if button



is pressed within the next 2s.

6.9 Changing the location mode

The unit can be set up to a location mode which doesn't allow it to be remotely controlled or switched to remote control by an interface card.



With the button **EXT** the user enables the remote control of the unit via an digital or analogue interface card and disables the  **local** mode.



With this button the user sets the unit into strict local mode, so that it is only controllable locally ( **local**), means by hand and access by any interface, analogue or digital, is denied.







6.10 Switching to the function manager

 The **SEQ** button switches the display to the function manager mode.

Switching to the function manager is only possible while the unit is in standby (output = off). The set values of voltage and current are set to 0V and 0A. For details about the function manager see section „6.15 The function manager“.

6.11 Activating the menu

 The main menu is accessed with the **MENU** button and the display changes to the main menu level. A text menu like this appears:

	Profile	Setting up and selecting user profiles
	Function	Setting up a function sequence
	Analogue interface	Settings for the internal analogue interface
	Communication	Configure the pluggable interface card
	Options	Default setup, unlock features, Lock device configuration
	About...	Manufacturer, service, SW version etc.

 A menu page is left to the next higher level by pressing the **ESC** button.



  The **SELECT** keys are used to select another menu entry.

 The **RETURN** button then enters the menu entry into the next sublevel by pressing it. The lowest menu level always shows up as a parameter page. See next topic for details.

6.12 Parameter pages

The parameter page is the lowest menu level. Here you can change many different parameters in order to set up the device.

 By pressing the **ESC** button the parameter page is left to the next higher level and no parameters are accepted.

  The **SELECT** keys are used to select a different parameter. The selected parameter is then displayed invertedly and can be changed with the left rotary knob.

 The **RETURN** button submits the changed parameters, which are accepted and stored and used. The parameter page is also exited to the next higher level.

6.13 Alarms, warnings and signals

Alarms, warnings and simple notifications (here called „signals“) can be acoustically signalled or optically in the display (see section „7.4 Configuring the control panel“).

An alarm has a higher priority than a warning or signal. Up to four alarms, warnings or signals can be displayed, which will cycle in an interval of two seconds. If an alarm occurs, one previous warning or signal will be suppressed if the total number exceeds four.

The power supply monitors the interface cards for transmission errors as well user-defined warnings and alarms.

The output voltage, the output current and the difference between actual and set value can be monitored.

The table below gives an overview of the possible errors and their meanings, as well as the selectable error types, as far as these are configurable.

Indication	Error type			Depending on	Description
	Alarm	Warning	Simple notification		
OV	·				Overvoltage at the power output
SYS	·				General system error
FCT	·				Function could not be saved and/or submitted
OT	·			1)	Overtemperature error
		·		2)	
CAN		·			CAN bus transmission error
U>	def.	def.	def.		Overvoltage supervision threshold exceeded
U<	def.	def.	def.		Undervoltage supervision threshold exceeded
I>	def.	def.	def.		Overcurrent supervision threshold exceeded
I<	def.	def.	def.		Undercurrent supervision threshold exceeded
U↗	def.	def.	def.		Set-actual comparison error at a positive voltage transition
U↘	def.	def.	def.		Set-actual comparison error at a negative voltage transition
I↗	def.	def.	def.		Set-actual comparison error at a positive current transition
I↘	def.	def.	def.		Set-actual comparison error at a negative current transition
P↗	def.	def.	def.		Set-actual comparison error at a positive power transition
P↘	def.	def.	def.		Set-actual comparison error at a negative power transition

1) OT disappear = OFF

2) OT disappear = auto ON

def. = definable

An **alarm** will shut down the output and has to be acknowledged before the output can be switched on again (also see section „6.14 Acknowledging alarms and warnings“).

A **warning** remains in display as long as it is not acknowledged and can temporarily switch off the power output, if „auto ON“ has been activated for a particular error.

A **signal** is only displayed and only as long as the cause of the error is persistent. If more than one signal is notified, they will cycle in the display in a 2s interval.

6.14 Acknowledging alarms and warnings



You can acknowledge alarms and warnings with the **ACK** button.

If you acknowledge a warning with this button while it still persists, it is turned into a signal and displayed furthermore. Else it is deleted and not displayed anymore.

6.15 The function manager

The function manager is used to create functions which can control the unit automatically. The user can build curves of set values after the function $f(U, I, \Delta t)$ with it. The function manager sets the set values in an interval of 2ms. This means, that only times for Δt of a multiple of 2ms can be set, for instance 50ms. If voltage or current changes between two points, a ramp which consists of a certain number of steps ($\Delta t : 2\text{ms}$, results in 25 steps for the example above) is built.

The function manager controls the power supply and puts the set values, which have been configured in the function. The actual progression of the output values is however determined by the load and the output capacity of the device.

Explanation of the used terms:

Function = the function consists of up to 5 linked sequence headers (starts in menu at  **Setup function**), which can consist of up to five differently configurable sequences.

Function layout = the configurations in the function layout are used by the function manager to set the operation (U/I/P or U/I/R) mode for the power supply. Furthermore, the repetition rate of the function and the arbitrary order of the sequences are set here. In dependency of the function layout the function manager processes the next sequence after the previous one has been processed and uses the settings from the sequence control of the next sequence.

Sequence = consists of the sequence control and 10 sequence points. If the function manager is going to process a sequence, it first of all sets the parameters given in the sequence control. The 10 sequence points are set consecutively and the whole process is repeated as often as the repetition rate for the particular sequence is set to.

Sequence control ( **Sequence control**) = defines the repetition rate of the sequence and the maximum set value of power during the processing of the sequence, as well as internal resistance (optionally, has to be unlocked)

Sequence point = a sequence always consists of 10 sequence points. The points are processed (=set) consecutively by the function manager from point 0 to point 9. The definition of the sequence point determines, which set values for voltage and current have to be reached after the given time Δt . This enables the user to create step functions by setting the time to 0ms or 2ms, as well as ramps with times from 4ms to 99h99m. A time value of 0ms is settable, but results in a real time value of 2ms, because set values are only set in 2ms steps.

Additionally to the function itself you can set up and use the supervision circuits in the profiles. The function manager can also be controlled via the communication with the interface cards with one additional feature: you can set a stop point at which the function shall stop.

Overview of the function manager display:

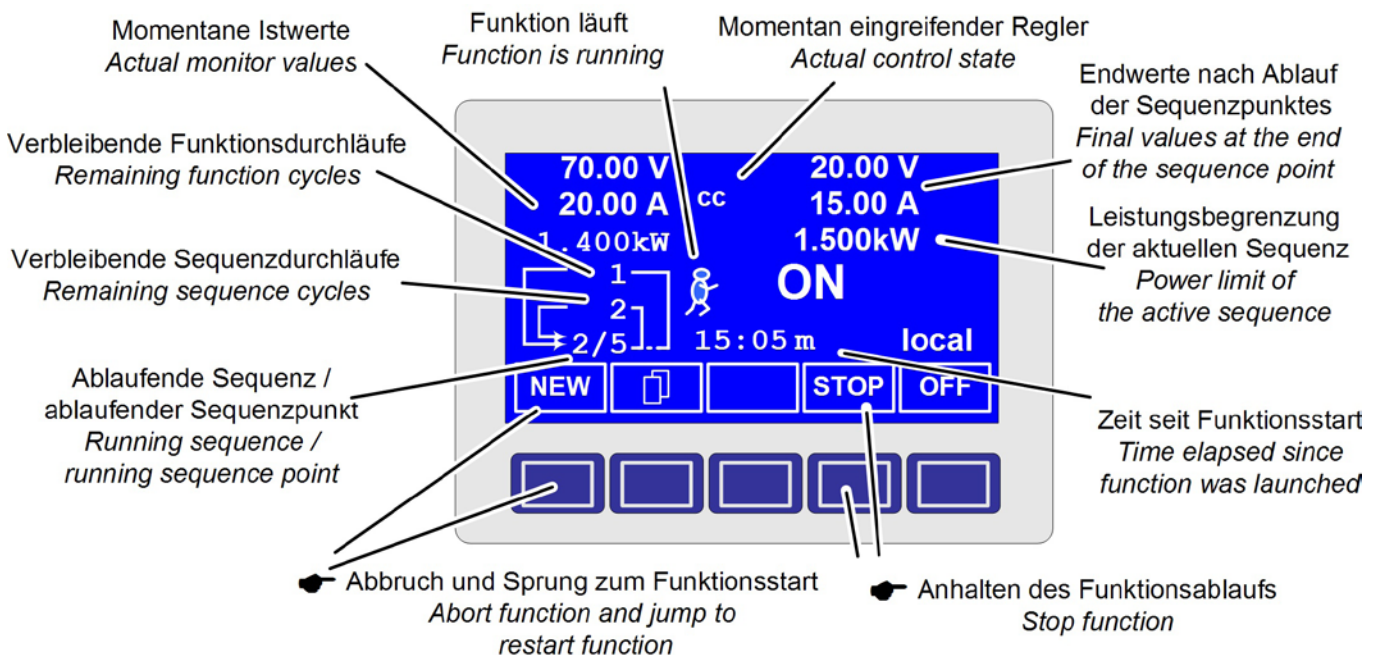

Figure 6

6.15.1 Configuring the function



The menu page **Function** leads to the following menu selection:

- Setup function**
- Sequence 1**
- Sequence 2**
- Sequence 3**
- Sequence 4**
- Sequence 5**

6.15.2 The function layout



You can define the operation mode of the power supply and the repetition rate here.

◆ **Function mode**

- = U/I/P Function uses U/I/P operation mode (only available at models from 1kW and with power regulation)
- = U/I Function uses U/I operation mode (models up to 640W)
- = U/I/R Function uses U/I/R operation mode (only if the option „internal resistance“ is unlocked)

Also see section „7.1 Defining operation parameters“.

◆ **Funct.cycles**

- = {1..254} it is repeated n times
- = ∞ it is repeated infinitely

◆ **Link sequences to one function**

Task: 1 2 3 4 5
Seq.: {-,1..5} {-,1..5} {-,1..5} {-,1..5} {-,1..5}

Beneath the particular tasks you can define of which sequences the function will consist and in which order the sequences are used. The symbol „-“ indicates, that the task is not defined and thus won't be processed.

6.15.3 Configuring sequences

The menu page **Sequence {1..5}** leads to the menu page where the sequences are edited.



It leads to the following menu selection:

- Sequence {1..5}** (number of the sequence to edit)
- Sequence control**
- Sequence points 0-4**
- Sequence points 5-9**

The repetition rate of the sequence, the maximum power and the internal resistance (optional, has to be unlocked) can be configured here, as well as the sequence points.

6.15.4 Sequence related parameters



Function mode : U/I/P

Function mode of the power supply is displayed.

- ◆ **Seq. cycles** {1..254, ∞} Default: 1
- = {1..254} it will be repeated n times
- = ∞ it will be repeated infinitely

- ◆ **P seq=** {0...P_{nom}} Default: P_{nom}

The maximum power given here is affecting the whole sequence.

This only with option „internal resistance“ (unlockable):

- ◆ **R seq=** {0Ω...20 * R_{nom}} Default: R_{nom}

The maximum internal resistance given here is affecting the whole sequence.

6.15.5 Defining the sequence points



A sequence consists of 10 sequence points. A sequence point consists of three values: the set values for U and I together with the time Δt.

- ◆ **Δt =** { 0...99:59h}

- ◆ **U[V] =** { 0... U_{nom}}

- ◆ **I[V] =** { 0... I_{nom}}

In order to understand how sequences are processed you need to consider the start condition of every sequence cycle:

Set values at the start of the function

The function always starts with
 U_{set} = 0V and I_{set} = 0A

Set values at reentrance into the sequence

If the sequence is repeated, the last processed sequence point alters the start condition of the next sequence cycle.

Example: Sequence point 9 is set to the values 80V/50A/250ms and the sequence is repeated, then the sequence starts with 80V and 50A, but with the time that was set for sequence point 0, for instance 500ms. During that 500ms, the set values will approach linearly to the defined values of sequence point 0.

6.15.6 Display during the function run

Also see the overview on the previous page.

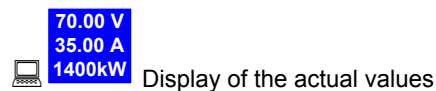

Display of the actual values

On the left side of the display the actual values are shown in small font. The status of the active control (CV/CC/CP) is displayed to the right of the corresponding value.

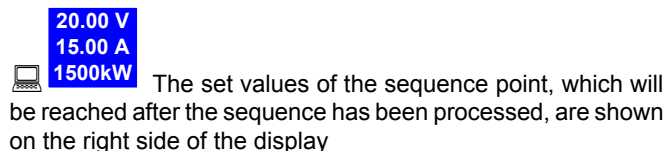

The set values of the sequence point, which will be reached after the sequence has been processed, are shown on the right side of the display

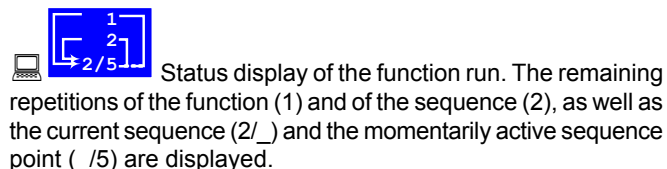

Status display of the function run. The remaining repetitions of the function (1) and of the sequence (2), as well as the current sequence (2/_) and the momentarily active sequence point (_/5) are displayed.

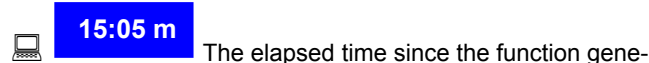
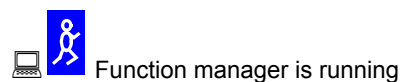
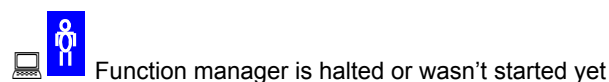

The elapsed time since the function generator was started is also displayed. The time display is stopped when the function manager stops. The **STEP**, **RUN** or **GO** keys are used to run the function manager in several ways. The time display will then continue to count.

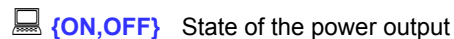

Besides the state of the power output an alarm, a warning or a signal can be displayed.

6.15.7 Controlling the function manager

The interactive control panel provides keys to control the function manager. You can halt, continue, reset it to the starting point or exit the function by using these keys.

The execution is also controllable via communication with an interface card. Here you can additionally set one stop point at one of the 50 sequence points. This sequence point is processed and the sequence/function is then halted.

ESC The **ESC** button exits the function manager and returns to the former state of the power supply.

STEP The **STEP** button is used to run a sequence stepwise. The current sequence point is executed after the button was pressed. After the „step“ has been executed, the set values, which are displayed in upper right corner of the display, are set.

RUN The **RUN** button starts the function manager and the function is run as it was defined. The sequence points are then processed consecutively.

Example for a simulation during standby:

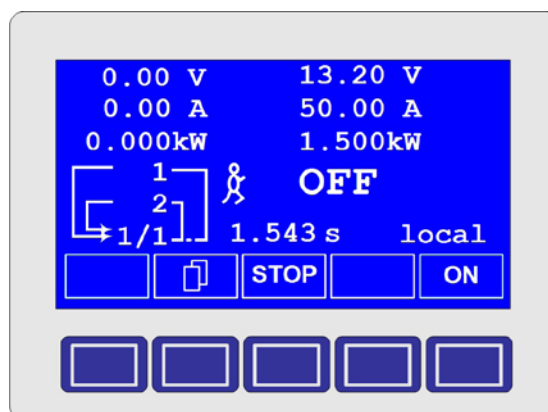

GO Use the **GO** button to continue the function after it was stopped.

NEW Alternatively, you can reset the function manager to the start of the current function with the **NEW** button.

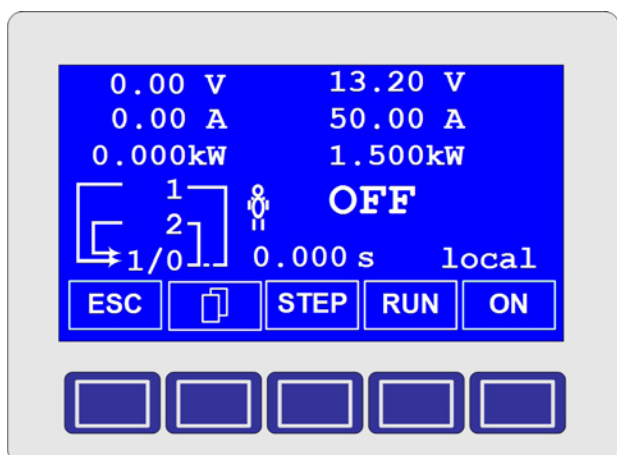

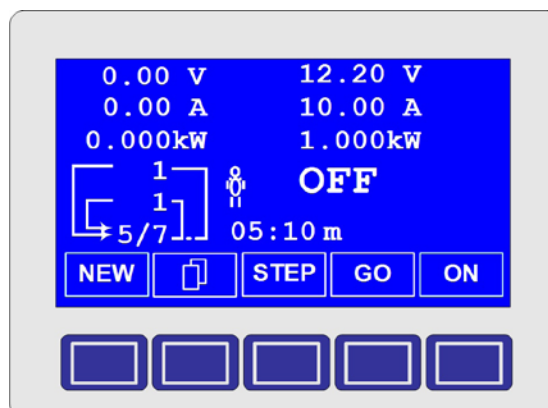

Before the function manager is really setting the power supply you can simulate the function on the display. During this

- the output is not switched on and
- the sequence points are processed step by step and can be verified this way.



7. Device configuration

Part 1: The menu Profile

Legend:
 Option: Innenwiderstand / Internal resistance
 Nicht bei jedem Modell verfügbar / Not available with every model

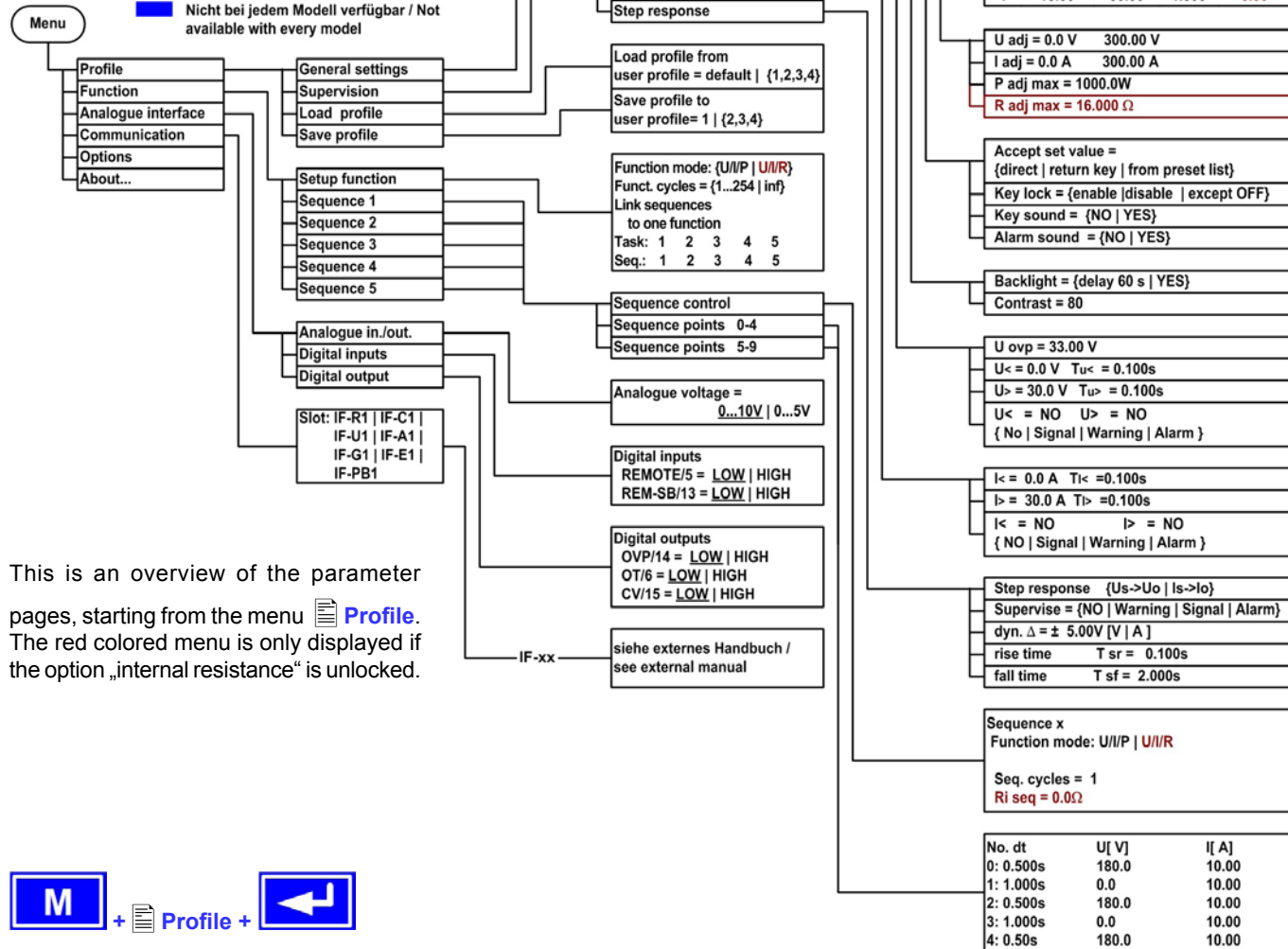





This is an overview of the parameter pages, starting from the menu  Profile. The red colored menu is only displayed if the option „internal resistance“ is unlocked.









The profiles are intended to minimize to time needed to set up the device at alternating users or to keep user defined settings for repeating applications. The last used profile is always loaded after the unit is switched on.

The menu entry  Profile leads you to following selection:

-  **General settings**
-  **Supervision**
-  **Load profile**
-  **Save profile**





The menu entry  General settings leads to following selection where the operation mode, the display itself and the handling (adjustment) of the unit can be configured:

-  **Setup operation mode**
-  **Preset list**
-  **Adjust limits**
-  **Control panel**
-  **Display**



The menu entry  Supervision leads to following selection where alarms, warnings and signals, as well as the corresponding supervision limits and reaction times are set up.

-  **U thresholds**
-  **I thresholds**
-  **Step response**



◆ **Load profile from user profile = {default, 1..4}**
 The current profil is replaced by the selected one.



◆ **Save profile to user profile = {1..4}**
 The current profile can be stored into one out of four profiles.

7.1 Defining operation parameters



The way of adjusting the set values, which operation mode is used, how the unit shall react after the mains has restored or the behaviour of the unit after an overtemperature error can be configured here.

U/I/P or U/I/R operation mode

◆ **Setup op. mode** Default: U/I/P

= U/I/P The power stage is controlled by voltage, current and power set values (only models from 1kW and with power regulation)

= U/I The power stage is controlled by voltage and current (models up to 640W)

= U/I/R The power stage is controlled by voltage, current and resistance set values and a settable, but not adjustable power set value (only with unlocked option „internal resistance control“)

Notice: the U/I/R operation mode can only be used after it has been unlocked in the **Options** menu. The unlock code can be purchased at the sales company who sold the power supply. The serial number of the unit is required to be told when purchasing the option, because the unlock code is related to it.

In U/I/R operation mode you can add an adjustable internal resistance to this voltage source.

The voltage set value is related to the off-load voltage U_o of the power supply. The off-load voltage is reduced by the product of $I_{act} \cdot R_{iset}$. The resulting voltage is calculated as follows:

$$U_{set} = (U_o - I_{act} \cdot R_i) \Big|_{I_{set}, P_{set}}$$

Clarification:

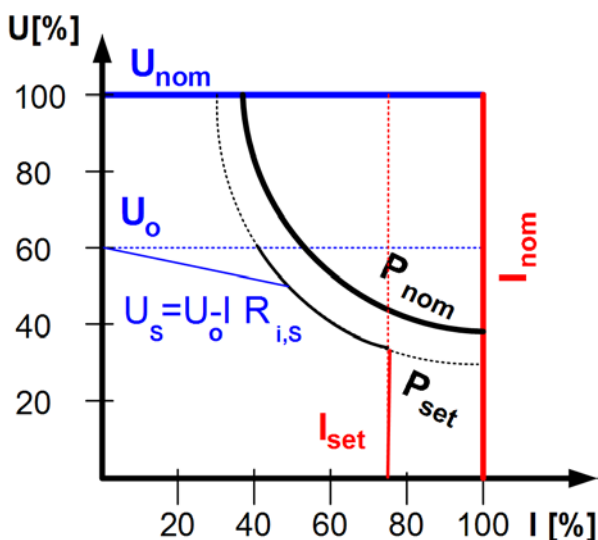
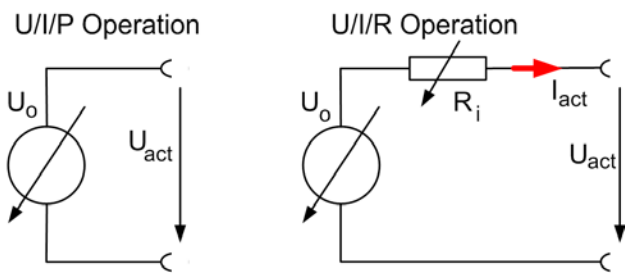

CR This is shown in the display while the internal resistance control is active and U/I/R operation is set.

The internal resistance R_{iset} is displayed instead of the power P_{set} while U/I/R mode is active. However, the actual value of the power is still displayed.

Reactivation after an overtemperature error

◆ **OT disappear** Default: auto ON

= OFF The power supply output remains switched off, even if the unit has already cooled down.

The error...

OT (overtemperature) is displayed as an alarm.

= auto ON The power supply is automatically switched on after the unit has cooled down below the overtemperature shutdown limit.

The error...

OT (overtemperature) is then displayed as a warning.

Warnings as well as alarms are only deleted from the display after they have been acknowledged (see also „6.13 Alarms, warnings and signals“).

Output state after „power on“

◆ **Power ON** Default: OFF

= OFF The power supply output remains switched off after the mains voltage returns or after the unit was switched on.

= restore The power supply output is set to the state it had before a mains voltage loss occurred or before the unit was switched off. In case it was ON when the unit was switched off, it will also be ON when the unit is switched on again.

7.2 Predefining preset lists



You can predefine up to four different presets.

No.	U [V]	I [A]	P [kW]	R [Ω]
1:	0.00	0.00	1.500	20
2:	10.00	10.00	1.200	25
-:	0.00	0.00	1.500	50
-:	0.00	0.00	1.500	100

Resistance values (red) only at unlocked option U/I/R. Power values (green) only with models from 1kW

With the parameter ◆ **Accept set value = from preset list** you can switch from the normal set values (eg. adjusted by the rotary knob) to one of the predefined sets or switch between predefined sets. You can actually „jump“ between set values with this option.

7.3 Adjustment limits



The maximum and minimum adjustment limits can be defined here. These limits are always interfering, in local or remote mode, i.e. unit is controlled by a PC.

Limits of the set value of voltage

◆ **U adj** Default: 0V, U_{nom}
 = { $U_{adj,min}$ } { $U_{adj,max}$ }

Whereas $U_{adj,min} = \{0 \dots U_{adj,max}\}$ and $U_{adj,max} = \{U_{adj,min} \dots U_{nenn}\}$

You can define the lower and upper limit of the adjustable voltage here. Set values which exceed these limits are not accepted, neither from the control panel nor from the remote control via a PC (communication with interface cards).

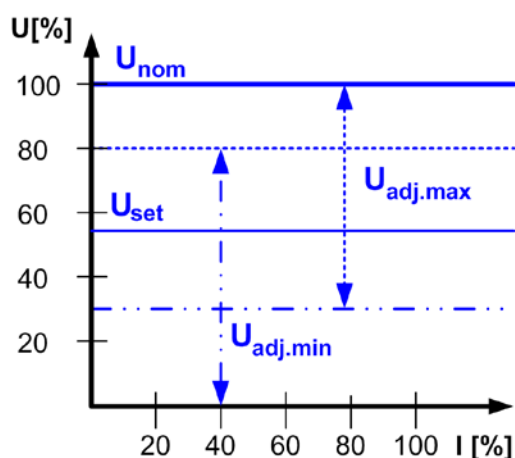

Limits of the set value of current

◆ **I adj** Default: 0A, I_{nom}
 = { $I_{adj,min}$ } { $I_{adj,max}$ }

Whereas $I_{adj,min} = \{0 \dots I_{adj,max}\}$ and $I_{adj,max} = \{I_{adj,min} \dots I_{nom}\}$

You can define the lower and upper limit of the adjustable current here. Set values which exceed these limits are not accepted, neither from the control panel nor from the remote control via a PC (communication with interface cards).

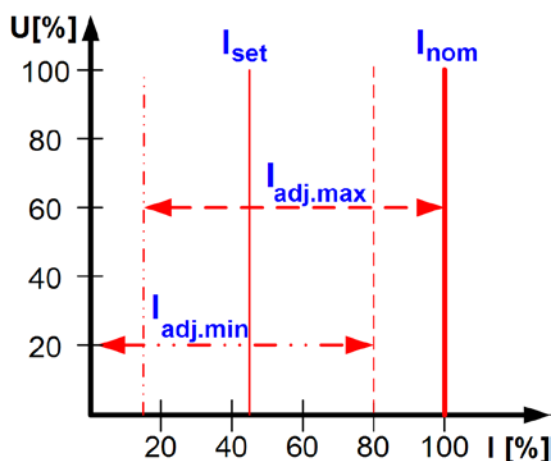

Limit of the set value of power (only models from 1kW)

◆ **P adj max** Default: P_{nom}
 = {0kW... P_{nom} }

You can define the upper limit of the maximum adjustable power here. Set values which exceed these limits are not accepted, neither from the control panel nor from the remote control via a PC (communication with interface cards).

Limit of the set value of internal resistance

(Optional, only accessible with unlocked U/I/R mode)

◆ **R adj max** Default: 0 Ω
 = {0 Ω ...20 * $R_{i,nom}$ }

If the U/I/R mode has been unlocked, you can set the upper limit of the maximum adjustable internal resistance. Set values which exceed these limits are not accepted, neither from the control panel nor from the remote control via a PC (communication with interface cards).

7.4 Configuring the control panel



The menu page **Control panel** lets you configure all parameters that are related to the graphical display and the control panel.

Configure how set values are manually adjusted

- ◆ **Accept set value** Default: *direct*
- = *direct* The set values are directly set to the power stage when changed with the rotary knobs
 - = *return key* The changed set values are only set if submitted with the **RETURN** button.
 - = *from preset list* You can choose sets from the **Preset List** with the rotary knobs and submit them with the **RETURN** button

Control panel lock

The control panel lock is only configured here.

- ◆ **Key lock** Default: *except OFF*
- = *except OFF* The control panel (buttons and rotary knobs) will be locked, except for the **OFF** button
 - = *enable* The control panel will be completely locked
 - = *disable* No lock

The control panel lock is used to prevent from unwanted changes to the set values or to the settings.

Note: this setting is only temporary. It is reset (=disable) after the device is switched on again or returns from mains blackout.

Sounds

◆ **Key sound** Default: NO

- = YES A short beep signals a button press
- = NO No signal if keys are pressed

◆ **Alarm sound** Default: YES

- = YES If an alarm or warning occurs an acoustic signal is emitted (beep) in short intervals
- = NO No acoustic signal for alarms/warnings

7.5 Configuring the graphic display



The menu page **Display** lets you configure all parameters related to the graphic display.

◆ **Backlight** Default: YES

- = YES The backlight is permanently on
- = delay 60s The backlight will be switched off with a delay of 60s after a button or a rotary knob has been used the last time

◆ **Contrast** Default: 80%

= { 70%...90% }

The contrast can be adjusted to suit the needs of the location where the unit is installed and for a clearer view at the values.

7.6 Supervision



The **Supervision** menu lets you configure the supervision of output voltage, output current and output power. You can also supervise a step function. The menu **Supervision** leads you to following menu selection:

◆ **U thresholds**

◆ **I thresholds**

◆ **Step response**

7.6.1 Voltage supervision



The menu page **U thresholds** lets you configure the over-voltage threshold (OVP) as well as the supervision circuits for over- and undervoltage.

Overvoltage protection (OVP)

◆ **U ovp** Default: $1,1 \cdot U_{nom}$

= { $U > \dots 1,1 \cdot U_{nom}$ }

Accuracy: 0.3% of U_{nom}
 Resolution: 4 digits
 Response time: <100us

The overvoltage protection is intended to protect the power supply output. But you can also, in order to protect the load, adjust it to the maximum allowed voltage of your load. The output is instantly shut down if this threshold is reached.

Example: an 80V unit can be adjusted up to 88V for U_{ovp}



OV It is displayed as an alarm.
 (also see „6.13 Alarms, warnings and signals“)

Overvoltage supervision

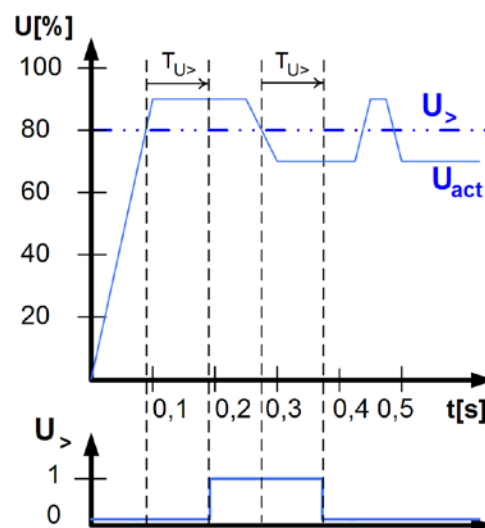
◆ **U>** Default: U_{Nom}

= { $U < \dots U_{ovp}$ }

◆ **Tu>** Default: 100ms

= { 0...99:59h }

This is slightly different from the OVP (see above). Here the voltage is also supervised, but it is notified with either an alarm, a warning or a signal and after a definable delay **Tu>**. The signal vanishes if the voltage is under the threshold for the time

Tu>. Hence you can supervise overvoltages without getting an OVP error every time or if you only want to get an alarm if the overvoltage is persistent longer than defined by **Tu>**.



U> Alarm: Overvoltage

This error shuts down the power output. An alarm has to be acknowledged, before the power output can be switched on again.



U> Warning: Overvoltage

The error is notified and remains until it is acknowledged and not persistent anymore.



U> Signal: Overvoltage

Undervoltage supervision

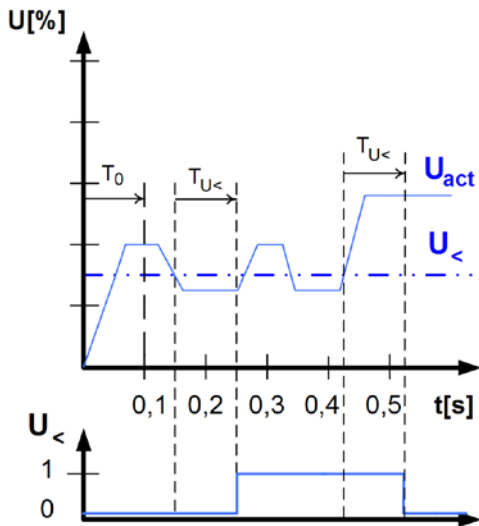

◆ U< Default: 0V

= { 0... U> }

◆ Tu< Default: 100ms

= { 0...99:59h }

As soon as the voltage falls below the undervoltage threshold, the undervoltage is notified after the response time ◆ Tu<. The notification vanishes, if the undervoltage limit is exceeded for the time ◆ Tu>. This undervoltage error is suppressed for T0=100ms after the power output was switched on.



U< Alarm: Undervoltage

This error shuts down the power output. An alarm has to be acknowledged, before the power output can be switched on again.



U< Warning: Undervoltage

The error is notified and remains until it is acknowledged and not persistent anymore.



U< Signal: Undervoltage

The analogue interface (IF-A1, optional) can signalise an undervoltage at one of the digital outputs.

7.6.2 Current supervision

I thresholds +



The menu page I thresholds lets you configure the supervision circuits for under- and overcurrent.

Undercurrent supervision

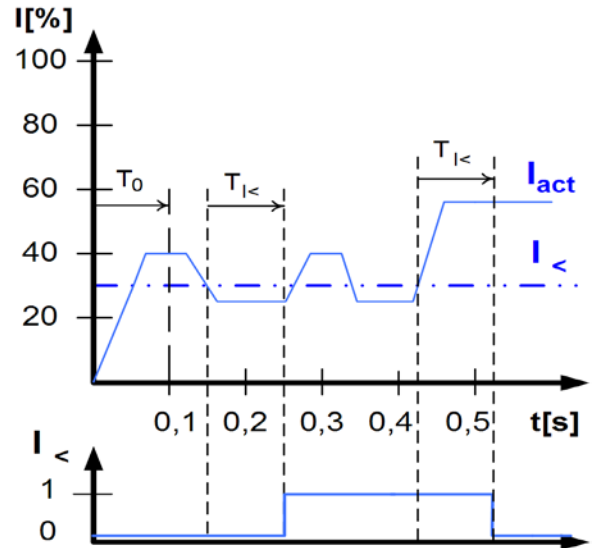

◆ I< Default: 0A

= { 0... I> }

◆ Ti< Default: 100ms

= { 0...99:59h }

The undercurrent error is signalled after the response time ◆ Ti<, if the actual value of the current falls below the adjusted undercurrent limit. The error notification vanishes if the actual current has exceeded the threshold again for the time ◆ Ti>. This undercurrent error is suppressed for T0=100ms after the power output was switched on.



I< Alarm: Undercurrent

This error shuts down the power output. An alarm has to be acknowledged, before the power output can be switched on again.



I< Warning: Undercurrent

The error is notified and remains until it is acknowledged and not persistent anymore.



I< Signal: Undercurrent

Overcurrent supervision

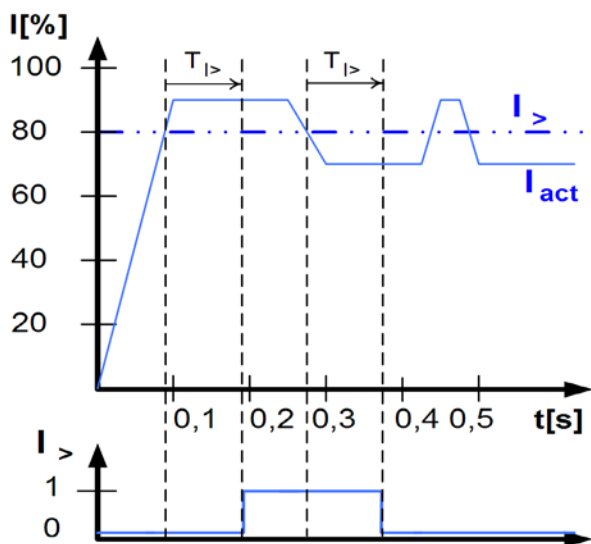

◆ $I >$ Default: I_{Nom}

= { $I < \dots I_{Nom}$ }

◆ $T_{i>}$ Default: 100ms

= { 0...99:59h }

The overcurrent error is signalled after the response time

◆ $T_{i>}$, if the actual value of the current falls below the adjusted overcurrent limit. The error notification vanishes if the actual current has exceeded the threshold again for the time ◆ $T_{i>}$. This overcurrent error is suppressed for $T_0 = 100\text{ms}$ after the output was switched on.

🖥️ ⚠️ $I >$ Alarm: Overcurrent

This error shuts down the power output. An alarm has to be acknowledged, before the power output can be switched on again.

🖥️ ⚠️ $I >$ Warning: Overcurrent

The error is notified and remains until it is acknowledged and not persistent anymore.

🖥️ $I >$ Signal: Overcurrent

The analogue interface (IF-A1, optional) can signalise an overcurrent or undercurrent at one of the digital outputs.

7.6.3 Step response supervision

📄 Step response +

The menu page 📄 **Step response** lets you configure the supervision circuits for the dynamic and static comparison of actual value and set value.

◆ **Step response:** Default: $U \rightarrow U_0$

$U_s \rightarrow U_0$ Supervision of the deviance between set value and actual value of voltage

$I_s \rightarrow I_0$ Supervision of the deviance between set value and actual value of current

◆ **Supervise** Default: **NO**

NO Supervision is inactive

Signal Supervision reports a signal

Warning Supervision reports a warning

Alarm Supervision reports an alarm

◆ **dyn. Δ** Default: 10%

= $\pm 8.00\text{V}$ Allowed tolerance for the voltage

= $\pm 5.00\text{A}$ Allowed tolerance for the current

The settling process of the power supply is determined by the load. After a set value has changed, a certain time elapses until the desired value is put to the power output. For instance, it can last some seconds for the voltage to go down from 100% to 0V at no-load operation, because the output capacitors need a certain time to discharge.

Supervision of a step response

The adjusted set value is compared with the measured actual value. If there is a difference between them and this difference is greater than the tolerance, the supervision will initiate an error after the settling time ◆ T_{sr} . See figure below.

◆ **rise time**

$T_{sr} = \{0\dots99:59\text{h}\}$ Default: 100ms

◆ **fall time**

$T_{sf} = \{0\dots99:59\text{h}\}$ Default: 2s

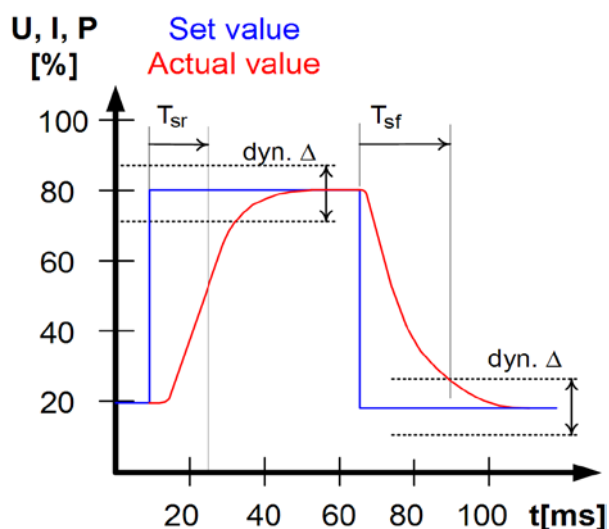

Notifications of the set/actual comparison

Example: The step from a lower set value to a higher set value was not performed within the settling time \blacklozenge Tsr. The supervision error is then notified as alarm, warning or signal.



Depending on the configuration of Step response the errors are notified.

Example: The step from a higher set value to a lower set value was not performed within the settling time \blacklozenge Tsf. The supervision error is then notified as alarm, warning or signal.



Depending on the configuration of Step response the errors are notified.

Part 2: The menu Options



The menu entry Options leads you to following menu selection:

- Reset configuration
- Enable R mode
- Setup lock

7.7 Reset to default configuration

You can reset all modifications of the setup to the default setup (the state the unit had when it was delivered).

After selecting the corresponding menu entry you will be prompted again to submit the choice to reset your current, personal configuration.

Attention: Even if the device configuration has been locked by a PIN it will be unlocked and overwritten!



- \blacklozenge Are you sure ? Default: NO
- = YES All modifications of the default setup are reset
 - = NO No change

7.8 Unlocking the U/I/R operation mode

R mode available:

- YES The U/I/R operation mode is unlocked and can be used
- NO U/I/R mode not enabled yet

The U/I/R operation mode can only be used after it was unlocked with a PIN code. This mode also has to be configured in the profile (see also „7.1 Defining operation parameters“).

The PIN code to unlock the U/I/R mode costs. In case you intend to use this mode, you can add this to your order or purchase it later.



\blacklozenge Activate R mode via pin code: 0 0 0 0

Use the pincode you received from your dealer here.

The resistance set value is then adjustable from 0Ω up to 20*Unom/Inom.

7.9 Locking the device configuration



It can be necessary, for security reasons, to lock the device configuration from access. You can enter a PIN code here, consisting of 4 numbers, each from 0 to 15.

\blacklozenge Lock setup via pin code: Enter the PIN code
pin code: {0..15}{0..15}{0..15}{0..15}

The lock can only be disabled with the same PIN code or by resetting the configuration with Reset configuration. The latter one deletes the custom setup and should only be used in case the PIN code has been forgotten.

If you activate the lock with the PIN code you can only change the configuration again after the PIN code was entered again and the setup is unlocked.

Attention! This only effects the user profile of the device, not the set values or the rotary knobs on the front panel!

8. Digital interfaces

8.1 General

The power supply supports various interface cards for communication (or analogue control, with IF-A1). All cards are galvanically isolated up to 2000V.

The digital interface cards IF-R1 (RS232), IF-C1(CAN) and IF-U1(USB) use a uniform communication protocol. Up to 30 units can be controlled from a PC at once with these cards.

The GPIB interface IF-G1 (IEEE 488) offers a SCPI command structure for up to 15 units per bus. The analogue card IF-A1 is a galvanically isolated, analogue interface with configurable in- and outputs.

The new Ethernet/LAN interface IF-E1 also provides SCPI command set. It features an additional USB port which makes the device accessible like with the IF-U1 card.

Another interface card for Profibus, the IF-PB1, completes the suite of available bus interface cards. The card comes together to Generic Station Device (GSD/GSE) files. Via Profibus, voltage, current, power and device condition can be set and monitored, other function may be implemented upon request. The card also features an additional USB port for firmware updates and alternative control of the device like with the USB card IF-U1.

8.2 Configuring the interface cards

The interface cards have to be configured once and each time they're replaced. This is done using the menu

 **Communication.**

 +  **Communication** + 

 **Slot: { IF-... }** depends on what is equipped

◆ **Device node** Default: 1

= {1..30} Up to 30 device nodes (addresses) can be assigned to device, one per unit. A device node must only be assigned once if multiple units are controlled.

If Profibus card IF-PB1 is equipped, this is available instead:

◆ **Profibus address** Default: 1

= {1..125} One of max. 125 possible addresses for slave can be selected.

An equipped interface card is automatically recognized by the unit. The menu selection displays the equipped card with its product code.

Configuring the various cards

Since all cards have different parameters to configure, these are explained in detail in the corresponding user instruction manual. Please refer to it.

9. Internal analogue interface

9.1 General

The internal, 15 pole analogue interface is located on the rear and offers, amongst others, following possibilities:

- Remote control of current and voltage
- Remote control of power 0...100% (models from 1kW and with power regulation)
- Remote monitoring of status (OT, OVP, CC, CV)
- Remote monitoring of actual values
- Remotely switching the output on/off

Useful hints:

- Controlling the device with analogue voltages requires to switch it to remote control with pin „REMOTE“ (5).
- Before connecting the application that is used to control the power supply, make sure to wire all leads correctly and check if the application is unable to input voltages higher than specified (max. 12V).
- The input REM-SB (remote standby, pin 13) overrides the pushbutton **ON**. It means, the output can not be switched on by the button if the pin defines the output state as „off“, except  **local** mode is active. Also see section 6.9.
- The output VREF can be used to build set values for the set value inputs VSEL, CSEL and PSEL. For example, if only current control is required, pin VSEL can be bridged to VREF and CSEL is either fed by an external voltage (0...5V or 0...10V) or via a potentiometer between VREF and ground. Also see next section.
- Putting in set values up to 10V while 0...5V range is selected will ignore any voltage above 5V (clipping) and keep the set value at 100%.
- **The ground of the analogue interface are related to minus output.**

9.2 Settings for the analogue interface

 +  **Analogue interface** + 

 **Analogue in./out.**

 **Digital inputs**

 **Digital outputs**

 **Analogue in./out.** selects the voltage range for the analogue

set values inputs and actual value outputs:

◆ **Analogue voltage** Default: **0...10V**

= **0...10V** Selects 0...10V for 0...100% set/actual values.

= **0...5V** Selects 0...5V for 0...100% set/actual values.

The reference voltage at pin VREF is automatically adjusted to the above selection and will be either 5V or 10V.

 **Digital inputs** defines if the digital control inputs will act at LOW or HIGH level.

◆ **REMOTE /5** Default: **LOW**

= **LOW** Unit switches to analogue remote control, if the pin is tied to LOW (ground).

= **HIGH** Unit switches to analogue remote control, if the pin is tied to HIGH.

Caution! This pin is tied to HIGH level by default. It means, that if setting HIGH is chosen and the pin is left open, the device will permanently stay in analogue remote control!

Pin	Name	Type ⁽¹⁾	Description	Level	Electrical specification
1	VSEL	AI	Set value: voltage	0...10V or 0...5 correspond to 0..100% of U_{Nom}	Accuracy < 0,1%
2	CSEL	AI	Set value: current	0...10V or 0...5V correspond to 0..100% of I_{Nom}	Impedance $R_i > 100k$
3	VREF	AO	Reference voltage	10V or 5V	Accuracy < 0.2% at $I_{Max} = +5mA$ Short-circuit-proof against AGND
4	DGND	POT	Reference potential for digital control signals		For +Vcc, control and status signals
5	REMOTE	DI	Toggle between internal or external control	External = LOW, $U_{Low} < 1V^{(4)}$ Internal = HIGH, $U_{High} > 4V$ Internal = open	U range = 0 ...30V $I_{Max} = +1mA$ at 5V Sender: Open collector against DGND
6	OT	DO	Overtemperature error	OT = HIGH, $U_{High} > 4V$ no OT = LOW, $U_{Low} < 1V^{(4)}$	Quasi open collector with pull-up to $V_{cc}^{(2)}$ At 5V at the output there will be max.+1mA $I_{Max} = -10mA$ at $U_{CE} = 0.3V$ $U_{Max} = 30V$ Short-circuit-proof against DGND
7	N.C.				Not connected
8	PSEL ⁽³⁾	AI	Set value: power	0...10V or 0...5V correspond to 0..100% of P_{Nom}	Accuracy < 0.5% Impedance $R_i > 100k$
9	VMON	AO	Actual value: voltage	0...10V or 0...5V correspond to 0..100% of U_{Nom}	Accuracy < 0.1% at $I_{Max} = +2mA$ Short-circuit-proof against AGND
10	CMON	AO	Actual voltage: current	0...10V or 0...5V correspond to 0..100% of I_{Nom}	
11	AGND	POT	Reference potential for analogue signals		For -SEL, -MON, VREF signals
12	+Vcc	AO	Auxiliary voltage output (Ref: DGND)	11...13V	$I_{Max} = 20mA$ Short-circuit-proof against DGND
13	REM-SB	DI	Output off	off = LOW, $U_{Low} < 1V^{(4)}$ on = HIGH, $U_{High} > 4V$ on = OPEN	Voltage range = 0...30V $I_{Max} = +1mA$ at 5V Sender: Open-Collector against DGND
14	OVP	DO	Overvoltage error	OVP = HIGH, $U_{High} > 4V$ no OVP = LOW, $U_{Low} < 1V^{(4)}$	Quasi open collector with pull-up to $V_{cc}^{(2)}$ At 5V at the output there will be max.+1mA $I_{Max} = -10mA$ at $U_{CE} = 0.3V$
15	CV	DO	Indication of voltage regulation active	CV = LOW, $U_{Low} < 1V^{(4)}$ CC = HIGH, $U_{High} > 4V$	$U_{Max} = 30V$ Short-circuit-proof against DGND

⁽¹⁾ AI = Analogue input, AO = Analogue output, DI = Digital input, DO = Digital output, POT = Potential

⁽²⁾ Internal Vcc = 13...15V

⁽³⁾ Only with models from 1kW

⁽⁴⁾ Default setting, can be changed in device setup

9.3 Example applications

Overview D-Sub socket

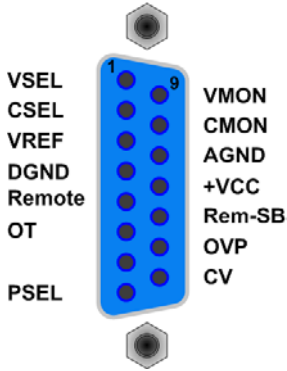

Attention! Never connect grounds of the analogue interface to minus (negative) output of an external control application (PLC, for example), if that control application is otherwise connected to the negative power supply output (ground loop). Load current may flow over the control leads and damage the device!

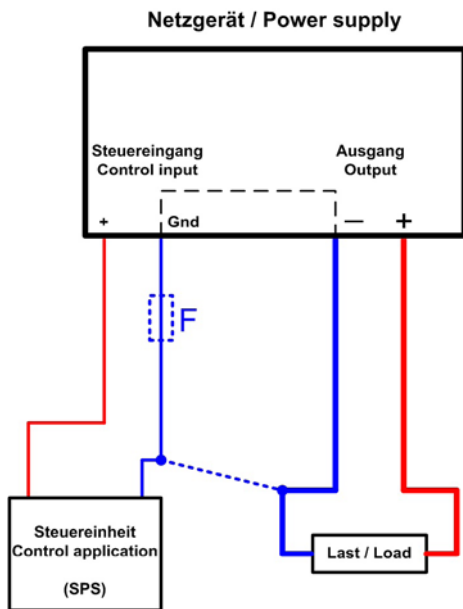

Figure 7

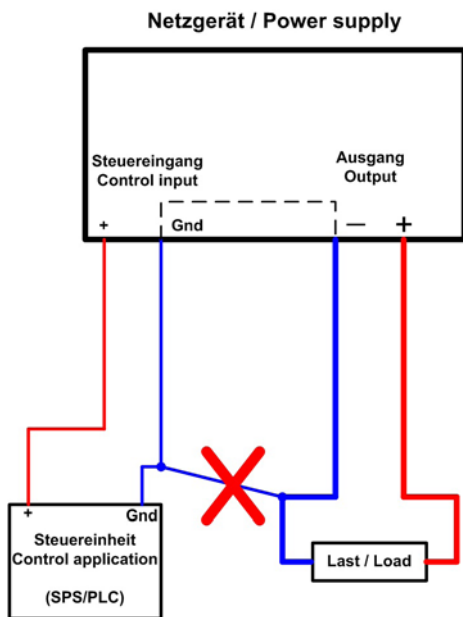
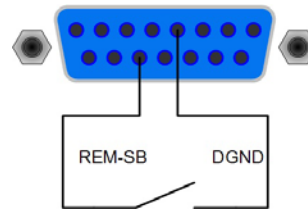

Figure 8

Output off

Pin „REM-SB“ is always operative and does not depend on the remote mode. It can thus be used to switch off the output without extra means.

All the user has to do is to ensure the level of the input is held.



Remote control of current and voltage

Two potentiometers between VREF and ground, sliders at the inputs VSEL and CSEL. The power supply can be controlled as with the rotary knobs on the front and can either operate as current or voltage source. In compliance with the max. 3mA for the VREF output, potentiometers with at least 10kOhm have to be used.

The power set value is here, for models with power regulation feature, tied to VREF and thus 100%.

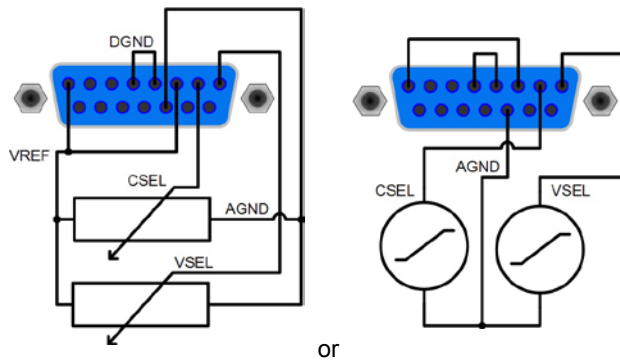

Remote control with power (where available)

Similar to the example above, but with adjustable power limit. Power adjustment only works at models from 1000W, which feature power regulation.

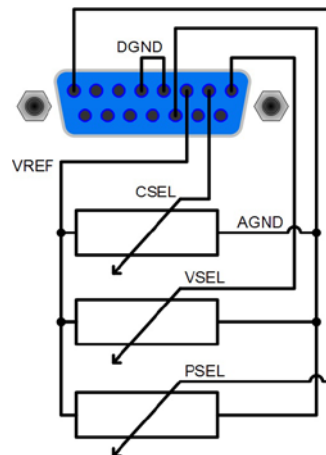

10. Other applications

10.1 Remote sense

Remote sense operation is used to compensate voltage drops along the leads between the power supply and the load. Because this is limited to a certain level, it is recommended to match the cross section of the leads to the output current and thus minimise the voltage drop. On the frontpanel if the device there is a terminal **Sense** where the sense leads are wired to with correct polarity. The power supply will detect the external sense automatically and compensate the output voltage by the actual voltage at the load instead of the output. The output voltage will be raised by the value of the voltage drop between power supply and load.

Maximum compensation: see „2.2 Device specific data“.

10.2 Connecting different types of loads

Different types of loads, such as ohmic loads (lamp, resistor), electronic loads or inductive loads (motor) behave differently and can retroact to the power supply. For example, motors can induce a countervoltage which may cause the overvoltage protection of the power supply to shut off the output.

Electronic loads have regulator circuits for voltage, current and power that can counteract to the ones of the power supply and may result in increased output ripple or other, unwanted side effects. Ohmic loads are nearly 100% neutral. It is recommended to consider the load situation when planning applications.

10.3 Mains undervoltage or overvoltage occurs

The device features an active rectification with PFC and a wide range input. This means, it can be operated at input voltages of approx. 90V...264V, respectively 180V...264V. Input voltages below 90V resp. 180V are considered as blackout, respectively as complete switch-off and will store the last condition, as well as switch off the power output.

Permanent input undervoltage or overvoltage must be avoided!

Important! Models with 1500W nominal power will derate the output power down to 1000W at input voltages below approx. 150V. At models with 3000W nominal power the derated output power will be 2000W, starting at around 205V.

10.4 Functions of terminal System Bus

The 8pole terminal **System Bus** is located on the rear and is used to connect leads for remote sense or to wire multiple devices for series or parallel connection.

Pin assignment:

- 1 : Sense +
- 2 : Sense -
- 3 : Master output Current
- 4 : Master output Voltage
- 5 : Slave input Current
- 6 : Slave input Voltage
- 7 : Share Bus
- 8 : Ground

Attention! The functions of pins 3-8, as described in the subsequent paragraphs, are only available at models from 1000W output power, except for the 720V model.

10.4.1 Series connection in Master-Slave mode

Note: not available for 720V model!

Note: only available with devices from 1kW nominal power!

For a series connection, it is recommended to use only devices with identical output current, else the unit with the lowest nominal output current will define the maximum current of the system.

One unit is always the master of the next unit, which becomes slave, and so on. When connecting more than two units, it is recommended to consider one certain unit as master and any other as slave. The slave(s) are controlled by the master via the slave input pins 3 and 4 of the terminal **System Bus**. Voltage and current can be controlled simultaneously, but also separately.

For an example wiring see figure 10. Voltage and current are here given by the master. In case only one of both, voltage or current, is going to be controlled, the other set value should be set to 100%.

In order to control the whole system remotely, it is sufficient to control the master via its analogue or digital interface. When reading actual values, the current monitor value will represent the overall system current, but the voltage monitor only the output voltage of the master. In order to get accurate readings, either the actual voltage is multiplied by the number of unit in the series connection (only applicable if all are same type) or all units will have to be read separately.

Attention! In case one of the output poles is going to be grounded, it is recommended for safety reasons to ground the pole with the lowest potential, in this case minus output (-) of the master.

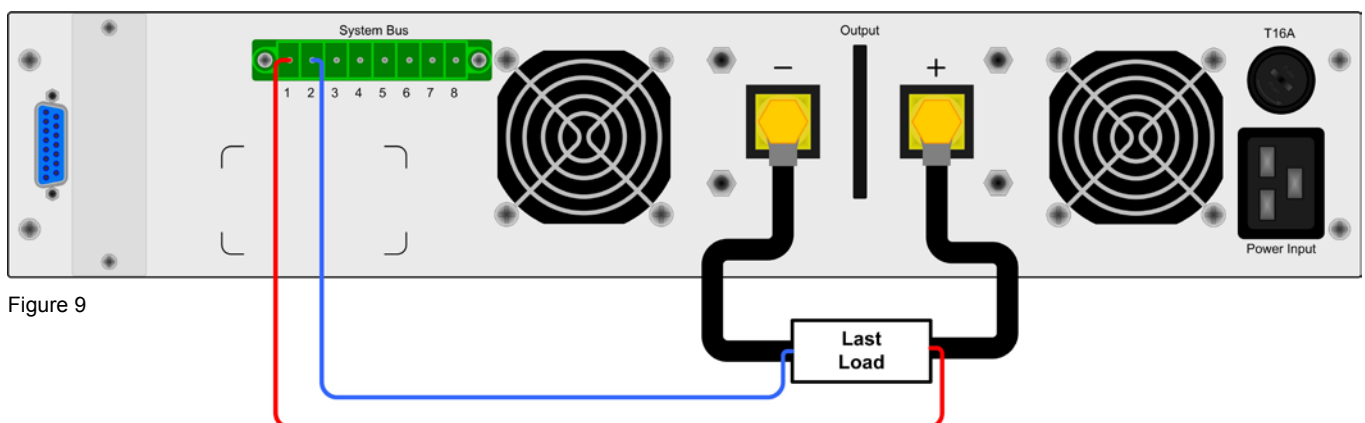

Figure 9

Attention! The system master must always be the unit with the lowest potential!

There are some restrictions and rules to consider because of safety and isolation reasons:

- The negative DC output pole of no unit in the series connection may be raised to a potential >300V against ground (PE)!
- The Share bus must not be wired!
- The grounds (AGND, DGND) of the analogue interfaces of the units must not be wired to each other!
- Remote sense must not be wired!

Example: Two identical units with 360V nominal voltage, for example PSI 8360-15 2U, shall be connected in series. When calculating, the total voltage of that series connection could go up to 720V. Looking at the resulting potentials on the negative outputs of the units, the 2nd unit's negative DC pole could be raised to 360V. This is not permitted! So the lower unit has to be limited to a certain maximum. The figure below clarifies that the resulting total voltage would be 660V:

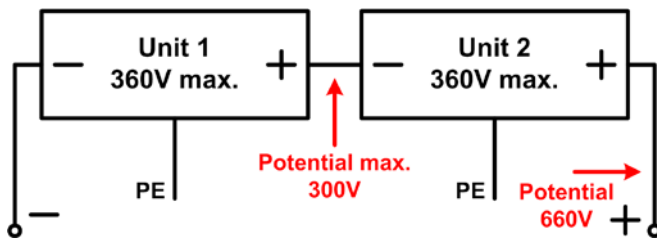

Caution! A total voltage of a series connection of 600V should not be exceeded!

10.4.2 Parallel connection in Share Bus mode

Note: only available with devices from 1kW nominal power!

Attention! Only units of the same type (voltage and current) must be used for this operation mode.

Share bus operation is used to gain a symmetric load current distribution when running multiple units in parallel connection.

Following connections are required: connect all (+) DC outputs of the units to each other and all (-) DC outputs to each other. Pin 7 (Share Bus) and pin 8 (Ground) of terminal **System Bus** of all units are also connected in parallel. In case remote sense is also required, all Sense+ and all Sense- inputs are connected in parallel and also with the load.

Important: in this operation mode, the unit with the lowest output voltage controls and defines the output voltage of the whole parallel connection. It means, any unit of the system could be in charge. Thus it is recommended to pick a unit that is used to control the whole system, while the set value of voltage for the remaining units is set to the required minimum. Voltage and power set value could be set to 100% or, if not desired, set to equal values on every unit so that the total results in what's required.

All units display their actual values, there will be no total formation of the system output current.

In order to control the whole system remotely, it is sufficient to control the master via its analogue or digital interface. When reading actual values, the voltage monitor value will represent the overall system voltage, but the current monitor only the output current of the master. In order to get accurate readings, either the actual current is multiplied by the number of units in the parallel connection (only applicable if all have the same nominal output current) or all units will have to be read separately.

For an example wiring see figure 11.

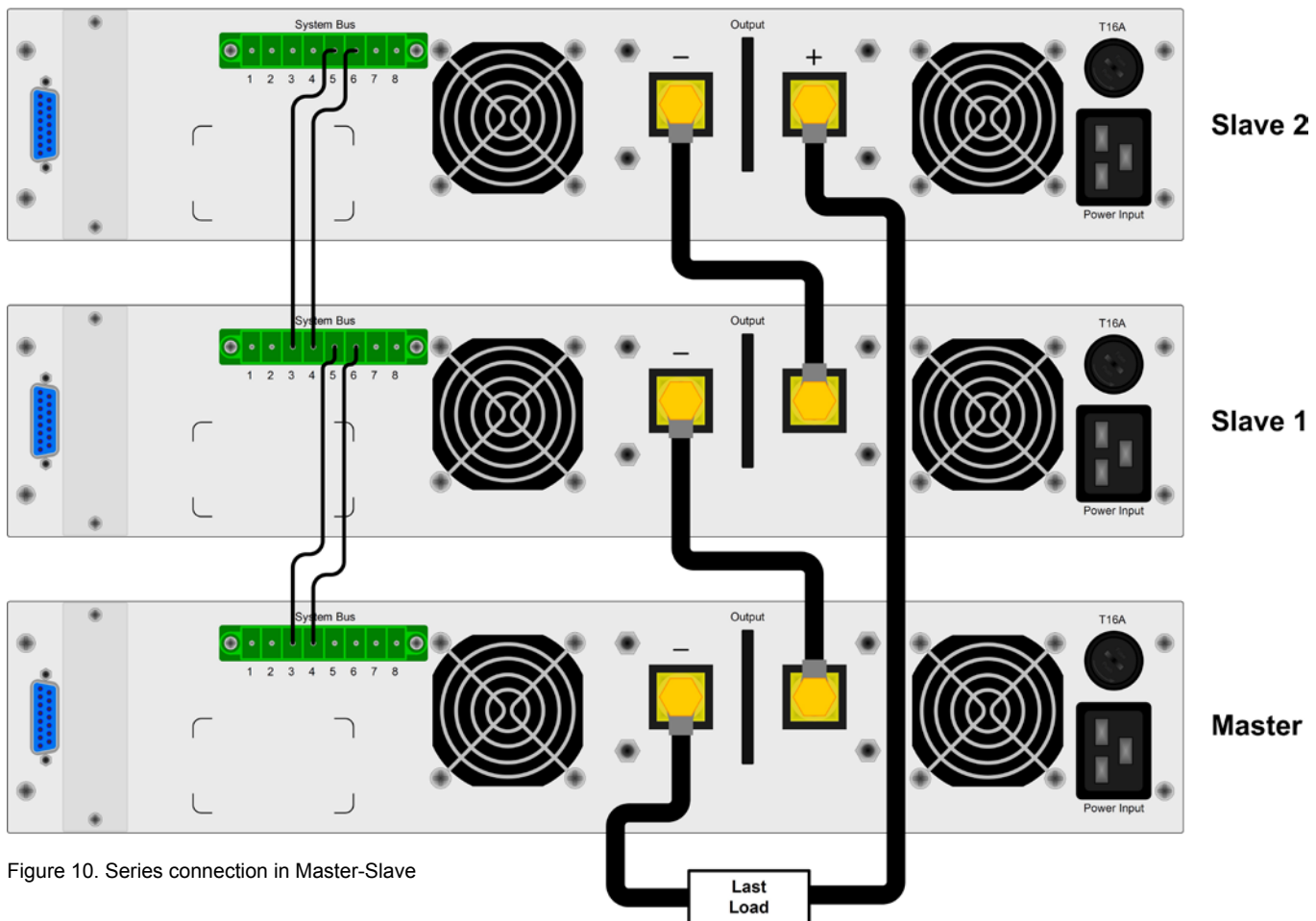

Figure 10. Series connection in Master-Slave

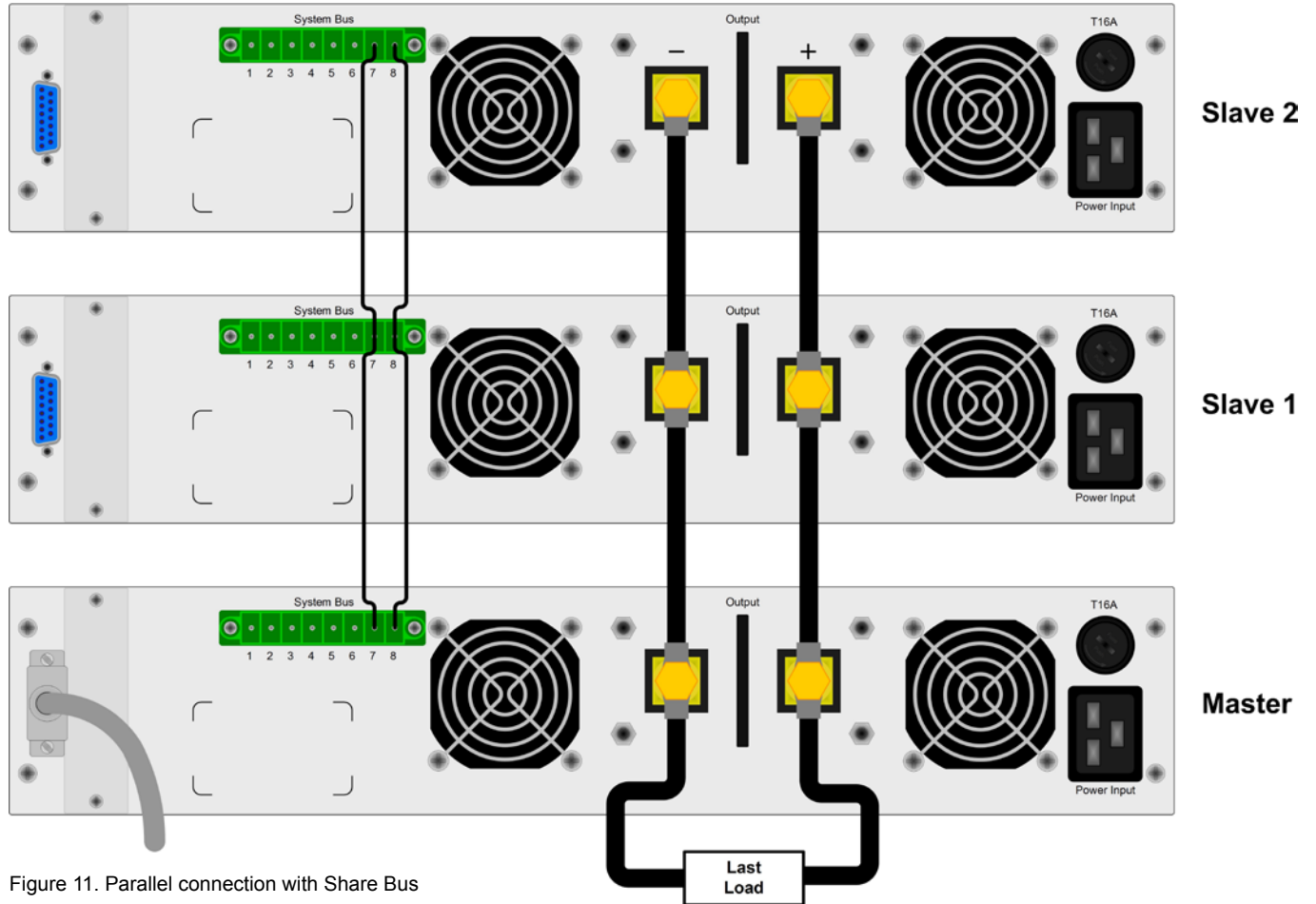

Figure 11. Parallel connection with Share Bus

10.4.3 Mixed connections

Mixed connections are parallel and series connections within one system. It is possible to do so, but we advise as follows:

First do the parallel connections, for example 3 units with 65V and 10A each. Then do the series connection (same three units again) in order to gain, for example, a 130V and 30A system.

If running high currents, it is advised to put the load in the middle of parallelly connected units, if an odd number.

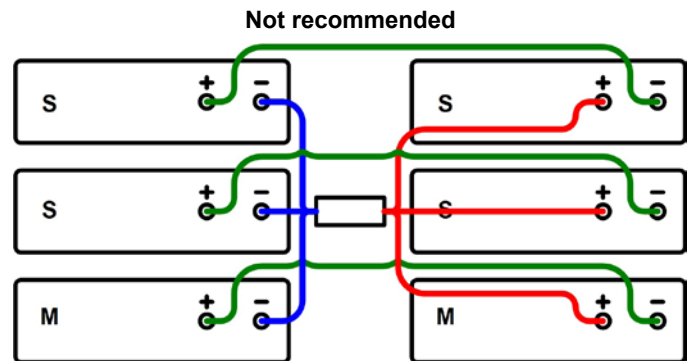
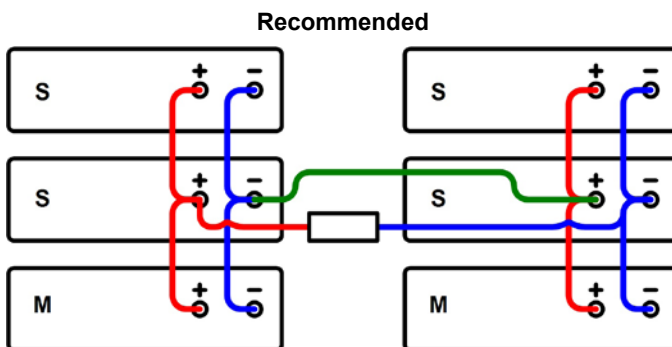

10.5 Networking

The figures below depict networking examples for the digital control of multiple devices in star-shaped (USB, RS232) or bus-like (CAN, GPIB) configuration.

Limitations and technical specifications of the bus systems and the interfaces apply.

With **USB** up to 30 units can be controlled with one PC, appropriate USB hubs with custom power supply assumed. This basically applies to RS232, too. Differences lie in the handling and the cable lengths.

With **CAN** up to 30 power supplies per address segment can be integrated into a new or existing CAN bus system. They are addressed by the device node and the RID.

With **GPIB** there is a limitation of max. 15 units on one bus, controlled by a GPIB master. Multiple GPIB masters can be installed in a PC in order to increase the number of addressable units.

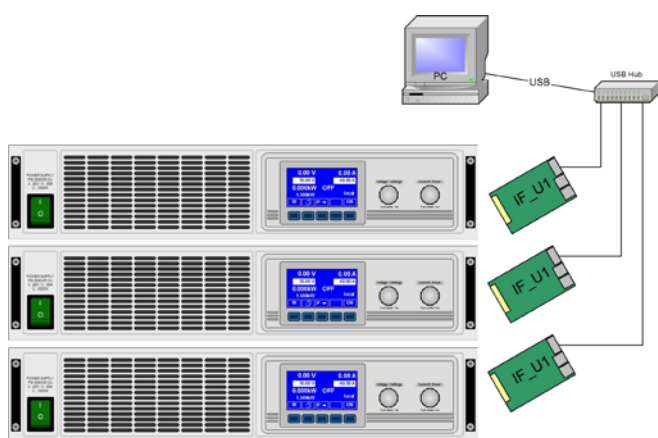

Figure 12. USB or RS232 networking

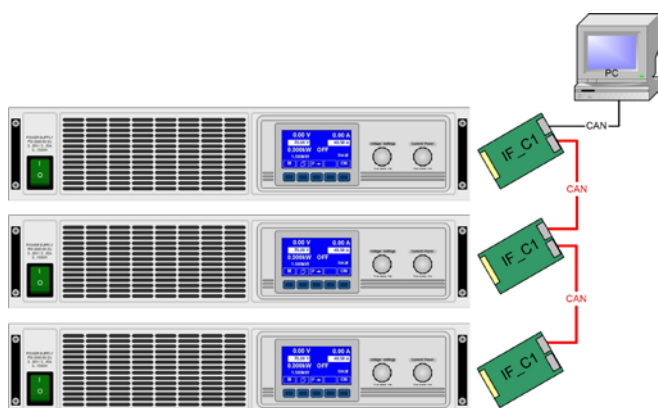

Figure 13. CAN networking example, also applies to GPIB

10.6 Accessories and options

Following accessories are optionally available:

a) USB-to-Analogue interface UTA12

Galvanically isolated remote control via USB (on PC side) and the device internal analogue interface.

b) Option IF: Digital interface cards

Pluggable and retrofittable, digital interface cards for USB, RS232, CAN, GPIB/IEEE (SCPI only), Ethernet/LAN (SCPI) or Profibus are available.

c) Option IF: Analogue interface card

An extended, 25 pin, galvanically isolated analogue interface is available. It is also pluggable and retrofittable.

Following options are available:

a) Option HS: High Speed Ramping (models from 1kW)

Increased dynamics of the output voltage by reduced output capacity. It must be pointed out, that other output related values also increase!

Note: this is a permanent modification which is not switchable.

b) Option ZH: Internal load with car ignition sequence

This internal module, also called two-quadrants module, offers continuous power up to 100W and pulse peak power of approx. 2400W. The main purpose is to discharge the device's output capacities faster than usual and thus to increase the dynamic behaviour of the output voltage, without worsen other output values. A second feature is the built-in car ignition sequence emulation which can be triggered by a button or remote signal. This is primarily used in the automotive industry. The module can be deactivated by a switch.

Note: only available for devices up to 360V nominal voltage.

c) Option IR: Internal resistance regulation

This option can be purchased subsequently and is unlocked with a code number in the device's setup menu.

After it is unlocked, the user can choose between U/I/P or U/I/R operation. The power set value will not be adjustable in U/I/R mode, it is then only defined as a limit in the device settings.

Note: it will eventually be required to update the device firmware before the option can be unlocked. Ask your supplier!

10.7 Firmware update

A firmware update of the device should only be done if the device shows erroneous behaviour or if new features have been implemented.

In order to update a device, it requires a certain digital interface card, a new firmware file and a Windows software called „Update tool“.

These interfaces are qualified to be used for a firmware update:

- IF-U1 (USB)
- IF-R1 (RS232)
- IF-E1 (Ethernet/USB)
- IF-PB1 (Profibus/USB)

In case none of the above interface types is at hand, the device can not be updated. Please contact your dealer for a solution.

The update tool and the particular firmware file for your device are obtainable from the website of the device manufacturer, or are mailed upon request. The update tool will guide the user through the semi-automatic update process.