

文件编号	SZ-QJ-LIR2477-001	受控状态	页数 11
------	--------------------------	------	-------

呈送: _____ (客户)

产品承认书

产品名称: 扣式锂离子充电電池

型 号: 3.6V-LIR2477

额定容量: 180MAH

客户确认	
公司名称:	
部 门:	
确 认 人:	
日 期:	

呈送日期: _____

深圳市琦捷电子有限公司		
批准	审核	编制

Specification for Magnetic Transducer	Page (页)	1/11
Model No (型号) .: LIR2477		



CONTENTS

1. 適用範圍 Applicable Scope
2. 產品類型 Type of Products
3. 主要特點 General Features
4. 規格特性表 Spec Chart
5. 電池特性 Battery Characteristics
6. 注意事項 Important Notes

Specification for Magnetic Transducer	Page (页)	2/11
Model No (型号) .: LIR2477		



1. 適用範圍 Applicable Scope

本承認書適用於琦捷電池生產的鋰離子充電電池。

This specs approval is applied only for the lithium-ion cell battery produced by Q&J.

2. 產品類型 Type of Products

種類: 扣式鋰離子充電電池 Type : Lithium-ion rechargeable cell battery

型號: LIR2477 Model : LIR2477

3. 主要特點 General Features

使用壽命長 Long Cycle Life

正常使用條件下，可迴圈使用充放電周期 ≥ 500 周，容量 $\geq 80\%$ 。

Under normal usage, the cycle life of the battery can be ≥ 500 circles while with capacity $\geq 80\%$

比能量大 High Power Density

高能量密度，使電池重量輕、體積小，更使用於小型用電設備。

High power density makes the battery light in weight and small in dimension. It can be used in small devices.

使用安全可靠 Safe and Reliable

沒有遊離的金屬鋰，電池使用更安全。

No floating metal lithium assures a safer usage.

工作電壓高 High working voltage

工作電壓高達 3.6V，大約是鎳鎘或鎳氫電池的 3 倍，可減小電池的使用數量。

Working voltage is up to 3.6V, approx. 3 times of the voltage of NI-MH or NI-CD, which reduces the quantity of the battery needed in certain application.

無記憶效應 No memory effect

無記憶效應，可隨時充放電使用。

No memory effect, can be used to charge and discharge at any time.

自放電率小 $\leq 1\%$ /月。 Low self-discharge rate : $\leq 1\%$ /month

一致性好 Good Consistency

公司內部按 ISO9000 標準建立質量保證體系，對生產全過程實行嚴格控制，使電池容量、內阻、放電平臺、荷電保持能力等性能保持良好的一致性。

Good consistency is showed in battery capacity, internal resistance, discharge platform and capacity retention. A strict complete internal quality control is subject to the ISO9000 system in the company's production.

Specification for Magnetic Transducer	Page (頁)	3/11
Model No (型号) .:	LIR2477	

4. 規格特性表 Spec Chart

標稱電壓 Nominal Voltage	3.6V
標稱容量 Nominal Capacity	180±10mAh
標準電流 Standard Current	16mA
最大電流（間斷） Max Current (pulse)	80mA
內阻 Internal Impedance	≤200mΩ
標準重量 Nominal Weight	5.6g

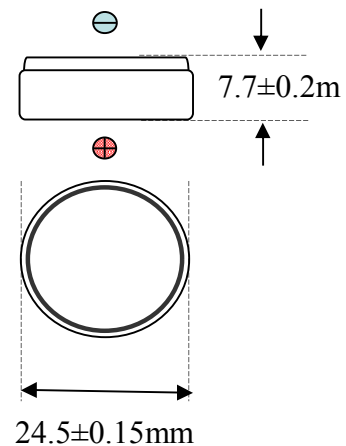

內阻值檢測標準：以 0.5CmA 恒流充電，當電池端電壓達到充電限制電壓 4.20V 後，轉為恒壓充電，當電流值小於 0.05CmA 時終止充電並擱置 1 小時後，用 1000Hz 內阻儀器進行檢測。

Internal resistance test standard:

CC charge 0.5mA / voltage up to 4.20V; Then CV charge.

Terminate charging when the charging current value is less than 0.05CmA.

Rest for 60 minutes, then test the battery by 1000Hz internal resistance tester.

5. 電池特性 Battery Characteristics

5.1 測試條件 Test Conditions

Temperature 溫度：20°C ±1

Relative Humidity: 相對濕度：≤75% ±5

Atmosphere pressure 大氣壓力：1atm

5.2 放電特性 Discharge Characteristics

在上述條件下測試：The test should be conducted under the condition below:

在環境溫度 20±5°C 的條件下，以 0.5CmA 恒流充電，當電池端電壓達到充電限制電壓 4.20V 後，轉為恒壓充電，當電流值小於 0.05CmA 時終止充電並放置不超過 1 小時，再以 0.5CmA 電流恒流放電到 2.75V

In a temperature of 20±5°C, CC charge 0.5CmA / voltage up to 4.20V; Then CV charge.

Terminate charging when the charging current value is less than 0.05CmA.

Rest for no more than 60 minutes,

Discharge CC at 0.5CmA to 2.75V.

5.3 充電特性 Charge Characteristics

電池可採用下列方法之一進行充電：The battery can be charged by one of the following methods:

標準充電：在環境溫度 20±1°C 的條件下，以 0.5CmA 恒流充電，當電池端電壓達到充電限制電壓 4.20V 時，改為恒壓充電，直到充電電流小於 0.05CmA，停止充電。

Standard Charge : Temperature 20±1°C, CC charge at 0.5CmA to 4.20V; turn to CV charge; Terminate charging when the charging current value is less than 0.05CmA.

快速充電：在環境溫度 20±5°C 的條件下，以 1CmA 恒流充電，當電池端電壓達到充電限制電壓 4.20V 時，改為恒壓充電，直到充電電流小於 0.05CmA，停止充電。

Fast Charge: Temperature 20±5°C, CC charge at 1.0CmA to 4.20V; turn to CV charge; Terminate charging when the charging current value is less than 0.05CmA.

Specification for Magnetic Transducer	Page (頁)	4/11
Model No (型号) .:	LIR2477	



充放電曲線請參閱圖 1 和圖 2；

For charging/discharging characteristics at various currents see fig 1 or 2.

不同溫度放電曲線請參閱圖 3；

For discharging characteristics at various temperatures see fig 3 or 4.

自放電曲線請參閱圖 4；

For Storage characteristics see fig 4.

迴圈壽命曲線請參閱圖 5。

For cycle life characteristics see fig 5.

Specification for Magnetic Transducer	Page (页)	5/11
Model No (型号) .: LIR2477		

圖 1. 不同電流條件下的充電特性

Fig.1 Charging Characteristics at various currents



圖 2. 不同電流條件下的放電特性

Fig. 2 Discharge Characteristics at various currents

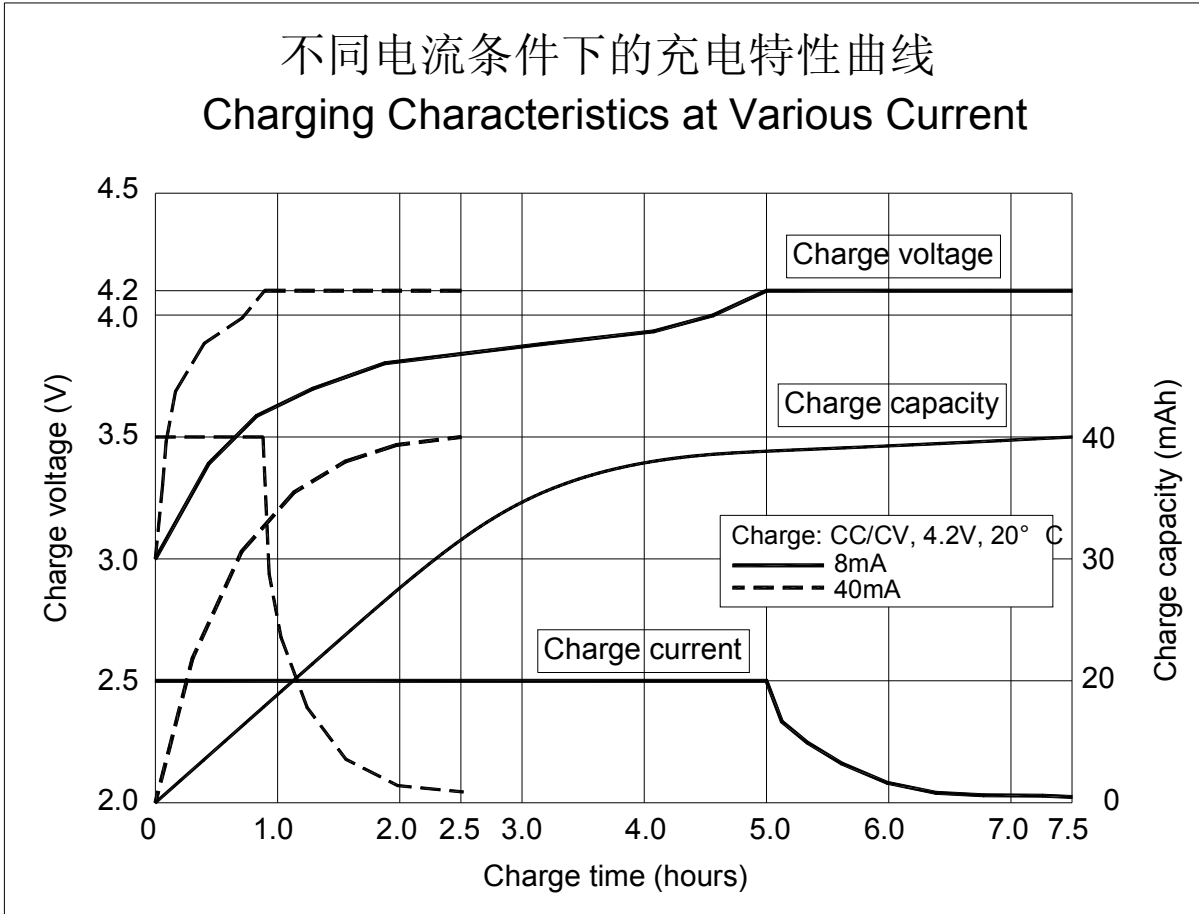

圖 3. 不同溫度條件下的放電特性

Fig. 3 Discharging Characteristics at various Temperatures



圖 4. 自放電保持特性
Fig. 4 Storage Characteristics

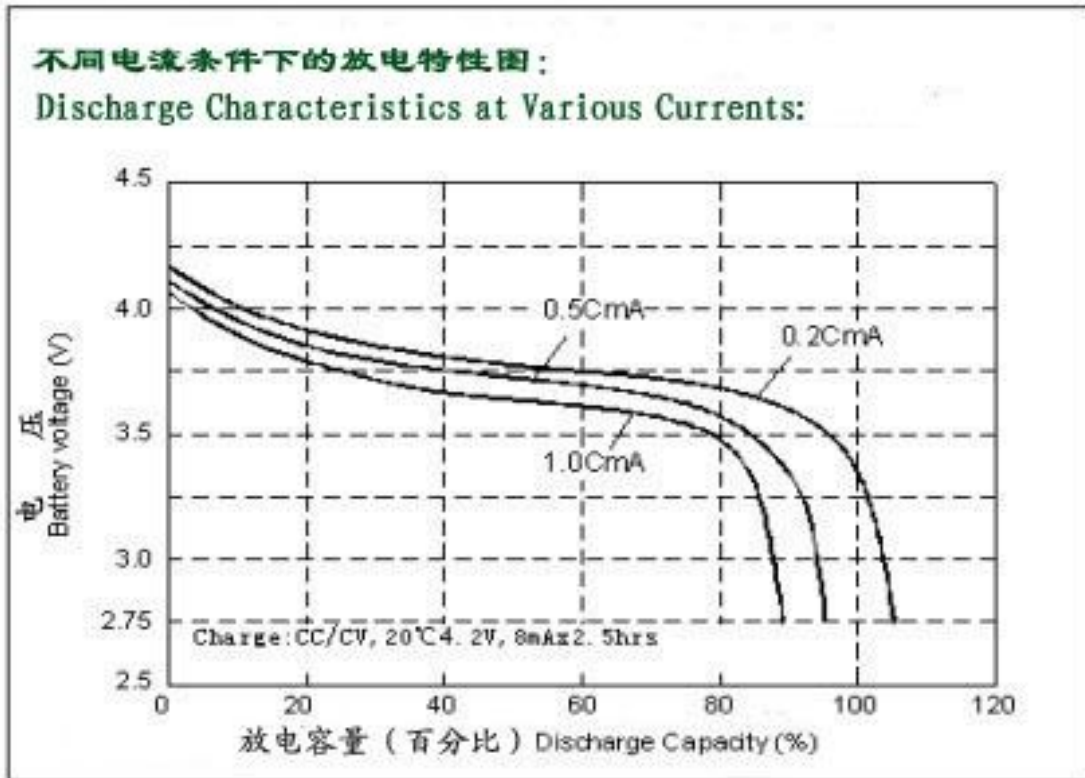

圖 5. 迴圈壽命曲線
Fig. 5 Cycle Life Chart



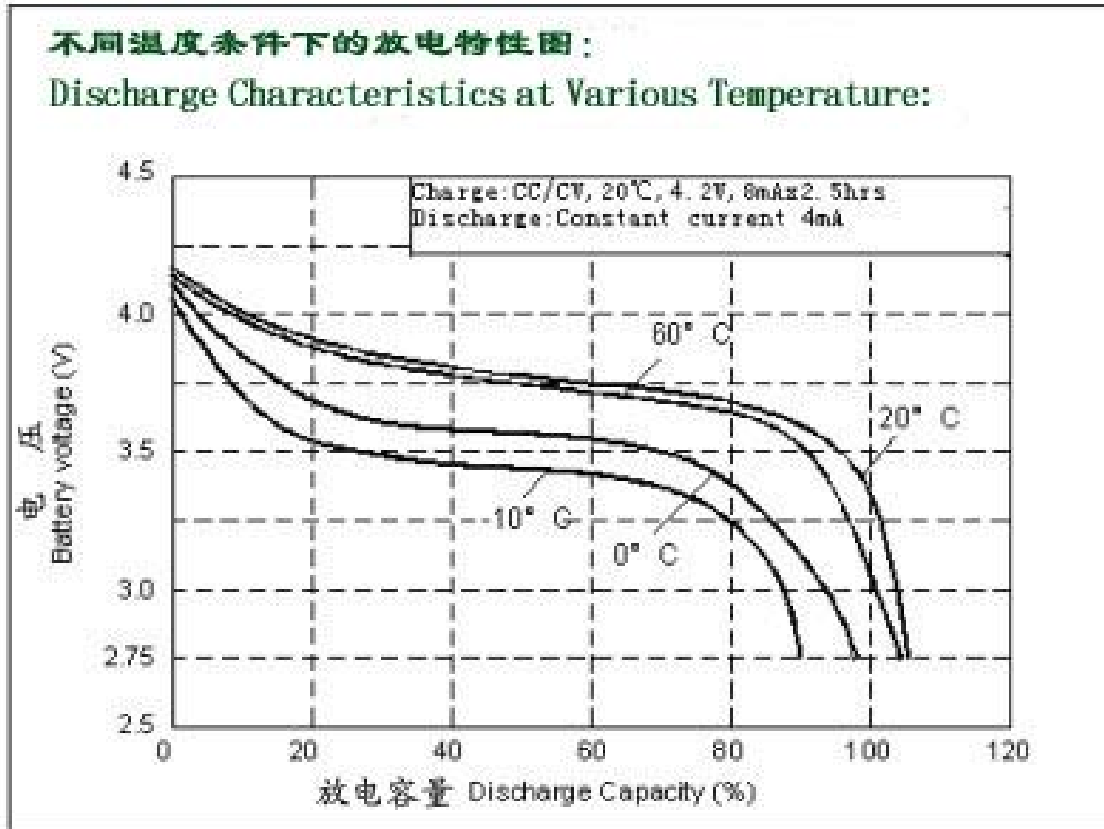

6. 注意事項 Important Notes

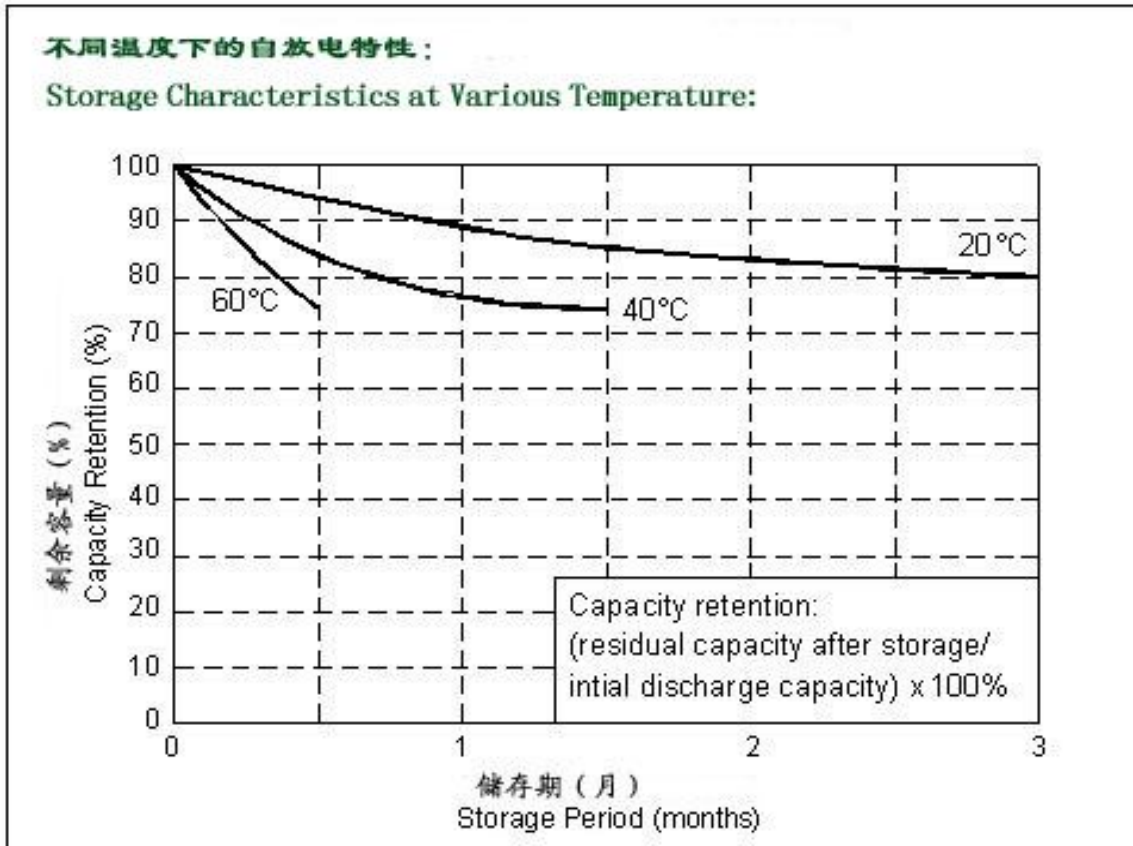
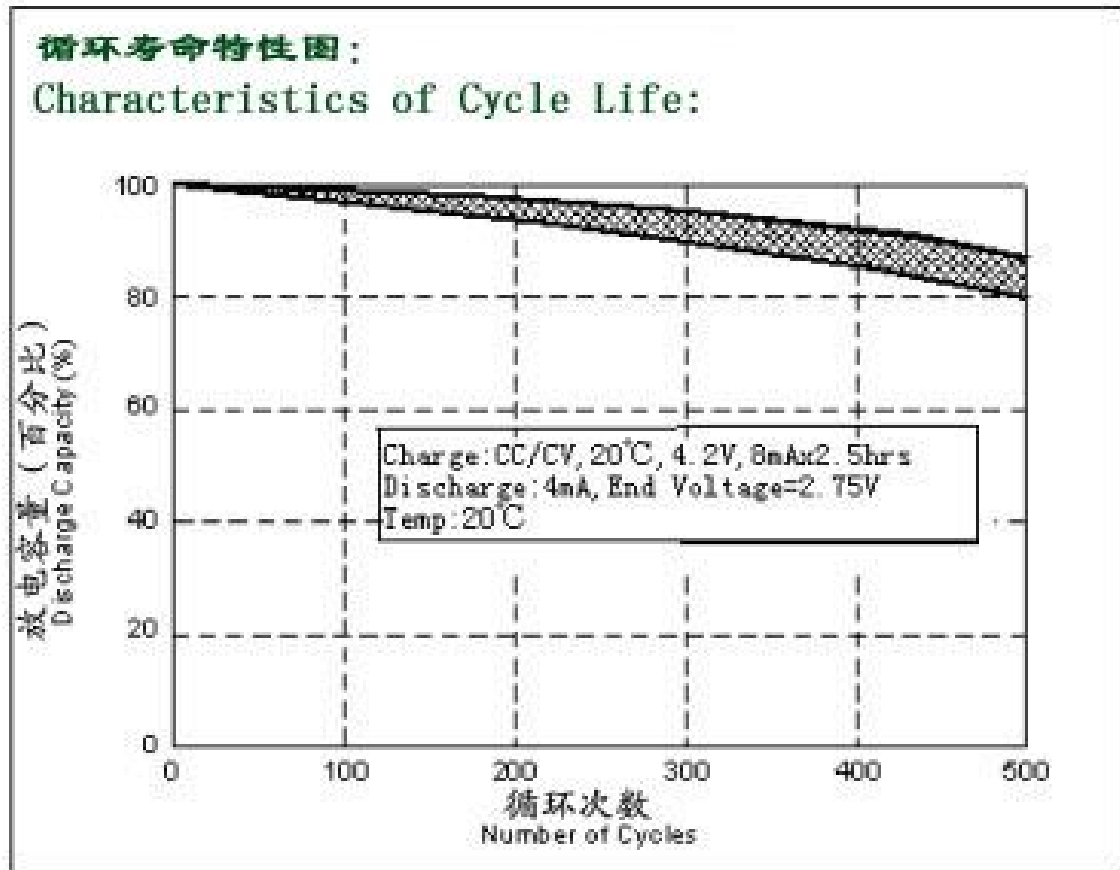
遠離熱源、火源；Keep away from source of fire and/or heat.

不要擅自解剖電池或電池組；Do not disassemble battery and/or battery pack.

不要將電池的正負極用金屬片連接，也不要將電池與能夠引起其短路的物品一起混放；
Do not connect the positive and negative pole directly using conductive metal; avoid short circuit.

不要將電池投入水中或弄濕；Do not put the battery into water or damp it.

不得拋電池；Do not cut the battery.

不得針刺、打擊電池；Do not strike or needle the battery.

用專用的充電器進行充電；Charge the battery using specified chargers.

不要用錫焊直接焊接引線與電池連接；Do not solder the battery directly.

不要反接電池的正負極；Observe the correct polarity (+/-)

不要將電池用於未指定的應用領域；Do not use the battery in un-specified application.

不得將電池與乾電池或其他類型電池混用；Do not mix the battery in usage with other types of battery.

使用電池前應該仔細閱讀使用說明書。Read the instruction manual carefully before use.

加载产品使用时，建议设计充放电保护电路 When the battery is used on load, it is recommended to design a charge/discharge protection circuit for the battery.

在常温环境下，如电池储存半年未使用要求对电池组织维护，维护办法：以 0.2CmA 电流恒流放電到 2.75V，搁置 5min 后，以 0.2CmA 恒流充電，當電池端電壓達到充電限制電壓 4.20V 後，轉為恒壓充電，當電流值小於 0.05CmA 時終止充電 When the battery is stored and not used under room temperature for over 6 months, it needs to be recharged by the procedure below:

- 1) Discharge by CC mode at 0.2CmA to 2.75V, then rest for 5 minutes
- 2) Charge by CC mode at 0.2CmA to 4.20V limit, then change to CV charge mode,
- 3) Cut off the charge when the charging current is less than 0.05CmA.

電池保質期為一年 Quality Warrant : one year.

Specification for Magnetic Transducer	Page (頁)	11/11
Model No (型号) .: LIR2477		