

**180KHz 60V 4A Switching Current Boost LED Constant Current Driver****XL6005****Features**

- Wide 3.6V to 32V Input Voltage Range
- 0.22V FB adjustable LED drive current
- Directly drive 11 Series 1W LED at  $V_{IN} \geq 12V$
- Fixed 180KHz Switching Frequency
- Max. 4A Switching Current Capability
- Up to 94% efficiency
- Excellent line and load regulation
- EN PIN TTL shutdown capability & With PWM Dimming Function
- Internal Optimize Power MOSFET
- Built in Soft-Start Function
- Built in Frequency Compensation
- Built in Thermal Shutdown Function
- Built in Current Limit Function
- Available in TO252-5L package

**Applications**

- LED Lighting
- Boost constant current driver
- Monitor LED Backlighting
- 7' to 15' LCD Panels

**General Description**

The XL6005 regulator is fixed frequency PWM Boost (step-up) LED constant current driver, capable of driving Series 1W/3W/5W LED units with excellent line and load regulation. The regulator is simple to use because it includes internal frequency compensation and a fixed-frequency oscillator so that it requires a minimum number of external components to work.

The XL6005 could directly drive 11 Series 1W LED units at  $V_{IN} > 12V$ .

The PWM control circuit is able to adjust the duty ratio linearly from 0 to 95%. An enable function, an over current protection function is built inside. An internal compensation block is built in to minimize external component count.



Figure1. Package Type of XL6005



180KHz 60V 4A Switching Current Boost LED Constant Current Driver XL6005

Pin Configurations

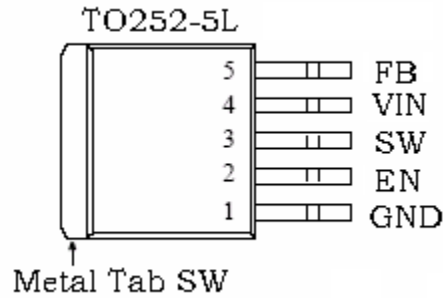

Figure2. Pin Configuration of XL6005 (Top View)

Table 1 Pin Description

Pin Number	Pin Name	Description
1	GND	Ground Pin.
2	EN	Enable Pin. Drive EN pin low to turn off the device, drive it high to turn it on. Floating is default high.
3	SW	Power Switch Output Pin (SW).
4	VIN	Supply Voltage Input Pin. XL6005 operates from a 3.6V to 32V DC voltage. Bypass Vin to GND with a suitably large capacitor to eliminate noise on the input.
5	FB	Feedback Pin (FB). The feedback threshold voltage is 0.22V.



180KHz 60V 4A Switching Current Boost LED Constant Current Driver XL6005

Function Block

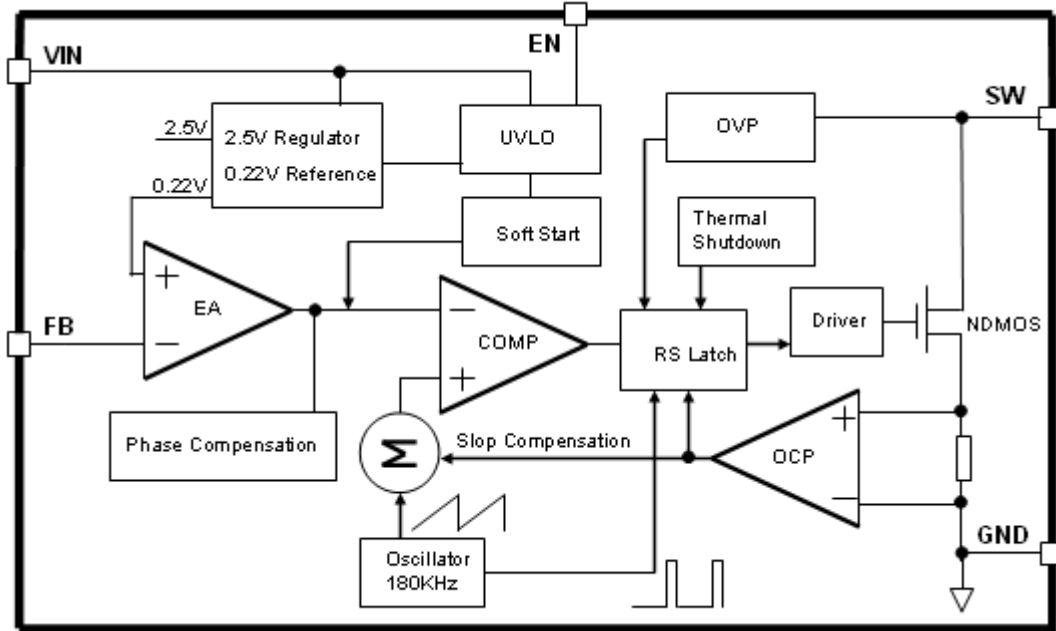

Figure3. Function Block Diagram of XL6005

Typical Application Circuit

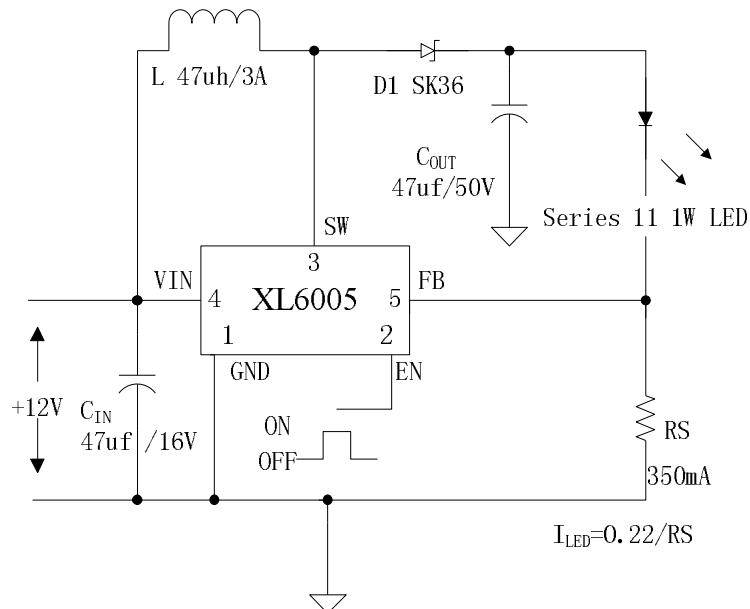

Figure4. XL6005 Typical Application Circuit



<b>180KHz 60V 4A Switching Current Boost LED Constant Current Driver</b>	<b>XL6005</b>
--	---------------

**Ordering Information**

Order Information	Marking ID	Package Type	Packing Type Supplied As
XL6005E1	XL6005E1	TO252-5L	2500 Units on Tape & Reel

XLSEMI Pb-free products, as designated with “E1” suffix in the par number, are RoHS compliant.

**Absolute Maximum Ratings (Note1)**

Parameter	Symbol	Value	Unit
Input Voltage	$V_{in}$	-0.3 to 36	V
Feedback Pin Voltage	$V_{FB}$	-0.3 to $V_{in}$	V
EN Pin Voltage	$V_{EN}$	-0.3 to $V_{in}$	V
Output Switch Pin Voltage	$V_{Output}$	-0.3 to 60	V
Power Dissipation	$P_D$	Internally limited	mW
Thermal Resistance (TO252-5L) (Junction to Ambient, No Heatsink, Free Air)	$R_{JA}$	50	°C/W
Operating Junction Temperature	$T_J$	-40 to 125	°C
Storage Temperature	$T_{STG}$	-65 to 150	°C
Lead Temperature (Soldering, 10 sec)	$T_{LEAD}$	260	°C
ESD (HBM)		>2000	V

**Note1:** Stresses greater than those listed under Maximum Ratings may cause permanent damage to the device. This is a stress rating only and functional operation of the device at these or any other conditions above those indicated in the operation is not implied. Exposure to absolute maximum rating conditions for extended periods may affect reliability.



<b>180KHz 60V 4A Switching Current Boost LED Constant Current Driver</b>	<b>XL6005</b>
--	---------------

**XL6005 Electrical Characteristics**

T<sub>a</sub> = 25°C; unless otherwise specified.

Symbol	Parameter	Test Condition	Min.	Typ.	Max.	Unit
<i>System parameters test circuit figure4</i>						
VFB	Feedback Voltage	V <sub>in</sub> = 5V to 12V, V <sub>out</sub> =24V I <sub>load</sub> =100mA	209	220	231	mV
Efficiency	η	V <sub>in</sub> =12V, V <sub>out</sub> =24V I <sub>out</sub> =1A	-	92	-	%

**Electrical Characteristics (DC Parameters)**

V<sub>in</sub> = 12V, GND=0V, V<sub>in</sub> & GND parallel connect a 100uf/50V capacitor; I<sub>out</sub>=100mA, T<sub>a</sub> = 25°C; the others floating unless otherwise specified.

Parameters	Symbol	Test Condition	Min.	Typ.	Max.	Unit
Input operation voltage	V <sub>in</sub>		3.6		32	V
Shutdown Supply Current	I <sub>STBY</sub>	V <sub>EN</sub> =0V		70	100	uA
Quiescent Supply Current	I <sub>q</sub>	V <sub>EN</sub> =2V, V <sub>FB</sub> =V <sub>in</sub>		2.5	5	mA
Oscillator Frequency	F <sub>osc</sub>		144	180	216	Khz
Switch Current Limit	I <sub>L</sub>	V <sub>FB</sub> =0		4		A
Output Power NMOS	R <sub>dson</sub>	V <sub>in</sub> =12V, I <sub>SW</sub> =4A		110	120	mohm
EN Pin Threshold	V <sub>EN</sub>	High (Regulator ON) Low (Regulator OFF)		1.4 0.8		V
EN Pin Input Leakage Current	I <sub>H</sub>	V <sub>EN</sub> =2V (ON)		3	10	uA
	I <sub>L</sub>	V <sub>EN</sub> =0V (OFF)		3	10	uA
Max. Duty Cycle	D <sub>MAX</sub>	V <sub>FB</sub> =0V		90		%



**180KHz 60V 4A Switching Current Boost LED Constant Current Driver XL6005**

**Schottky Diode Selection Table**

Current	Surface Mount	Through Hole	VR (The same as system maximum input voltage)				
			20V	30V	40V	50V	60V
1A		✓	1N5817	1N5818	1N5819		
3A		✓	1N5820	1N5821	1N5822		
		✓	MBR320	MBR330	MBR340	MBR350	MBR360
	✓		SK32	SK33	SK34	SK35	SK36
	✓			30WQ03	30WQ04	30WQ05	
		✓		31DQ03	31DQ04	31DQ05	
		✓	SR302	SR303	SR304	SR305	SR306
5A		✓	1N5823	1N5824	1N5825		
		✓	SR502	SR503	SR504	SR505	SR506
		✓	SB520	SB530	SB540	SB550	SB560
	✓			50WQ03	50WQ04	50WQ05	

**Typical System Application for VIN=12V to driver 11 x 1W series LED units**

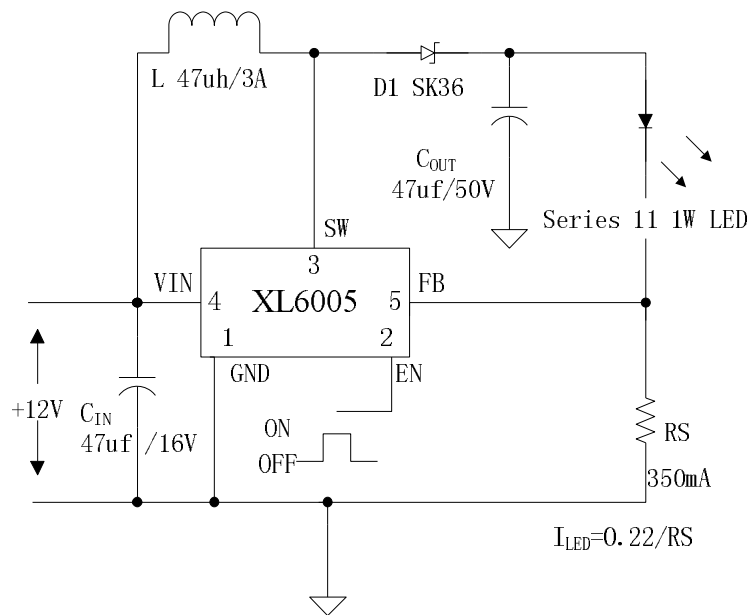

Figure5. XL6005 System Parameters Test Circuit (12V ~11 x 1W LED)



180KHz 60V 4A Switching Current Boost LED Constant Current Driver XL6005

Typical System Application for VIN >= 12V to driver 6 x 3W series LED units

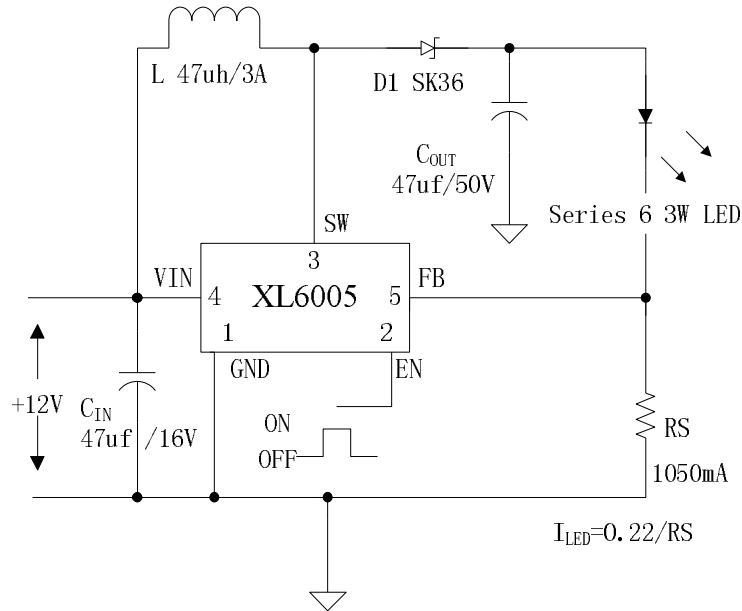

Figure6. XL6005 System Parameters Test Circuit (12V ~ 6 x 3W LED)

Typical System Application for VIN >= 24V to driver 11 x 3W series LED units

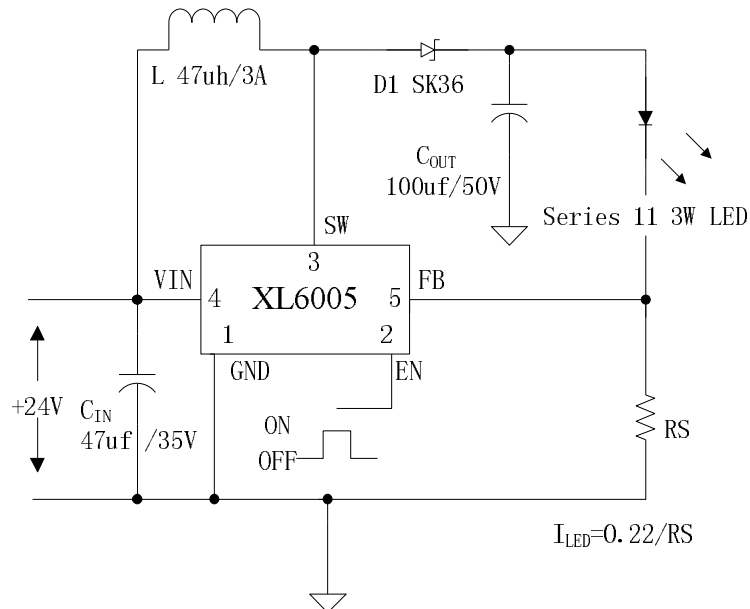

Figure7. XL6005 System Parameters Test Circuit (24V ~ 11 x 3W LED)



180KHz 60V 4A Switching Current Boost LED Constant Current Driver **XL6005**

Typical System Application for VIN>=12V to driver 11 series x 40 parallel White LED Array

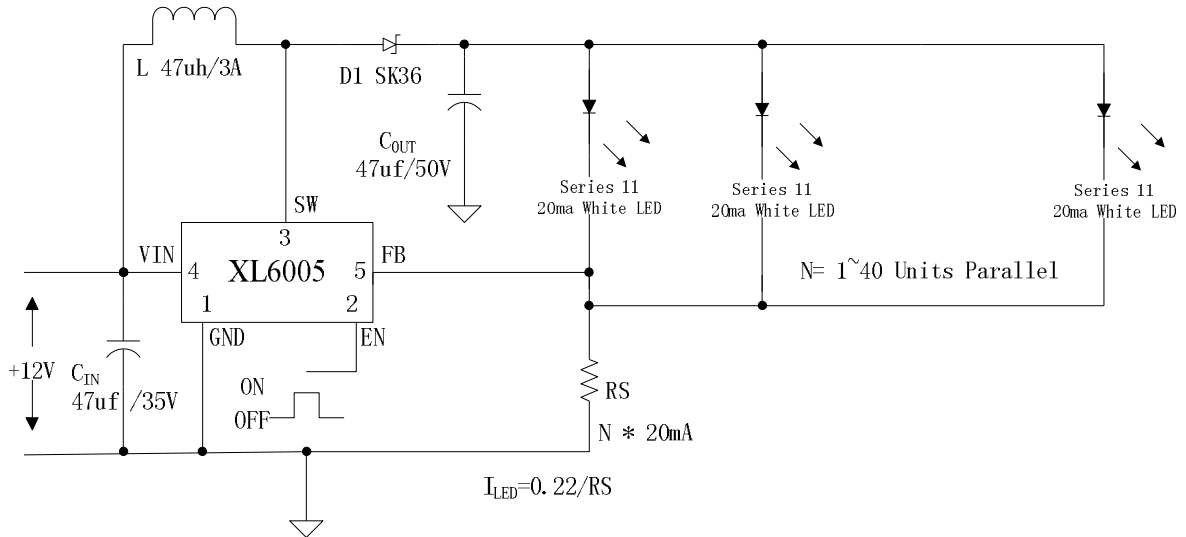

Figure8. XL6005 System Parameters Test Circuit (12V ~ 11 x 40 White LED)

Typical System Application for SEPIC Buck-Boost LED Driver

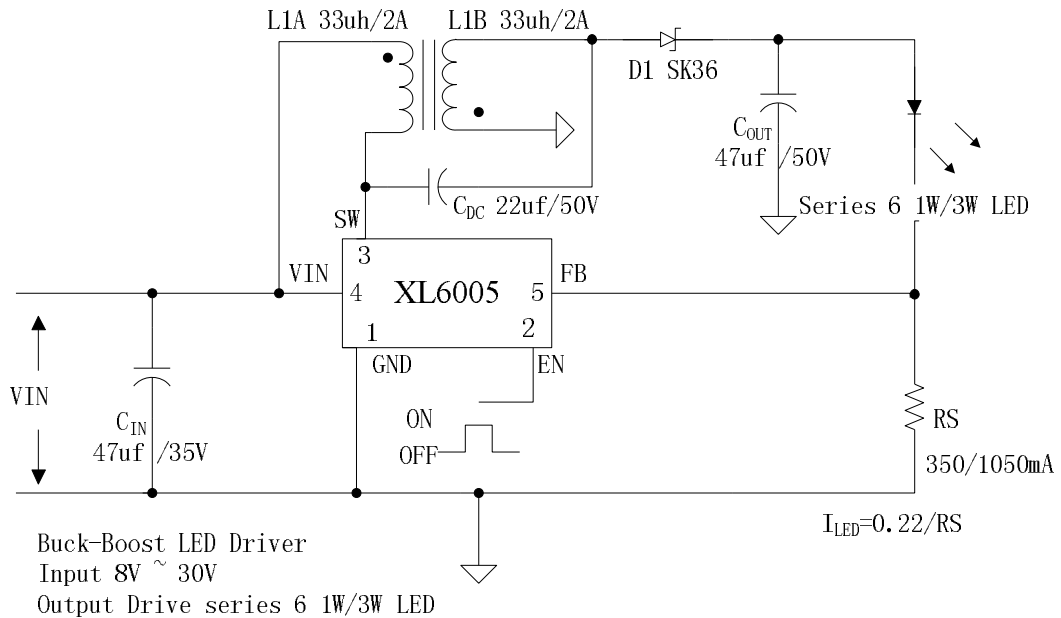

Figure9. XL6005 System Parameters Test Circuit (Buck-Boost LED Driver)





**180KHz 60V 4A Switching Current Boost LED Constant Current Driver** **XL6005**

**Typical System Application for  $V_{IN} \geq 12V$  to driver 6 x 3W series LED units With Dimming Function**

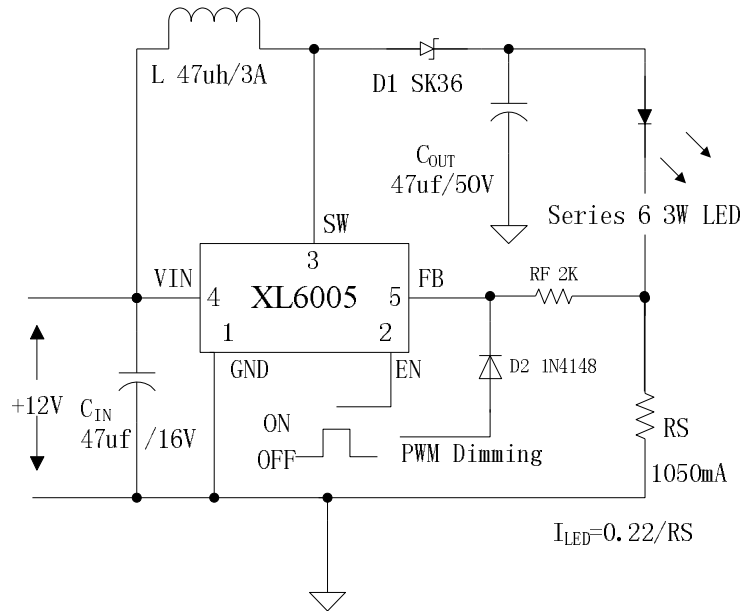
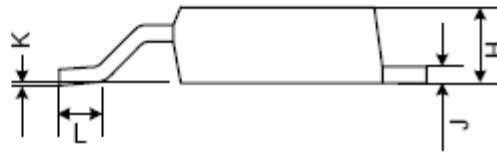
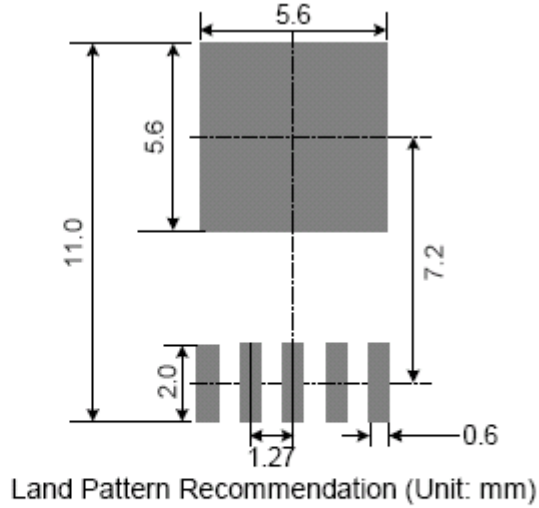
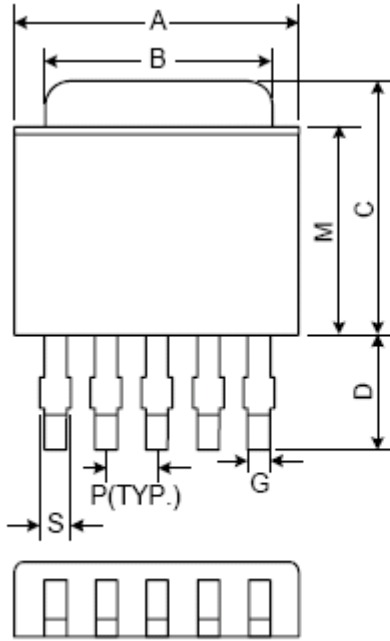

Figure10. XL6005 System Parameters Test Circuit (12V ~ 6 x 3W LED with Dimming Function)



Package Information

TO252-5L



Symbol	Dimensions In Millimeters			Dimensions In Inches		
	Min.	Nom.	Max.	Min.	Nom.	Max.
A	6.35	6.60	6.85	0.250	0.260	0.270
B	5.20	5.35	5.50	0.205	0.211	0.217
C	6.80	7.00	7.30	0.268	0.276	0.287
D	2.20	2.50	2.80	0.087	0.098	0.110
P	1.27 REF.			0.050 REF.		
S	0.50	0.65	0.80	0.020	0.026	0.031
G	0.40	0.50	0.63	0.016	0.020	0.025
H	2.20	2.30	2.40	0.087	0.091	0.094
J	0.45	0.52	0.58	0.018	0.020	0.023
K	0.00	0.08	0.15	0.000	0.003	0.006
L	0.90	1.20	1.63	0.035	0.047	0.064
M	5.40	5.80	6.20	0.213	0.228	0.244