



Features

- Wide 8V to 40V input voltage range.
- Fixed 5V output voltage.
- Maximum 2.4A output current.
- Fixed 150KHz switching frequency.
- Internal optimize power MOSFET.
- High efficiency up to 92%.
- Built in output short shutdown function.
- Excellent line and load regulation.
- Built in thermal shutdown function.
- Built in current limit function.
- Available in SOP8L package.

Applications

- Car Charger.
- Battery Charger.
- USB Power Supply.

General Description

The XL2012 is a 150 KHz fixed frequency PWM buck (step-down) DC/DC converter, capable of driving a 2.4A load with high efficiency, low ripple and excellent line and load regulation. Requiring a minimum number of external components, the regulator is simple to use and include internal frequency compensation and a fixed-frequency oscillator.

The XL2012 built in output short protection function. When short protection function happens, the chip will be shutdown. An internal compensation block is built in to minimize external component count.



Figure1. Package Type of XL2012



5V/2.4A 150KHz 40V Buck DC to DC Converter For USB Interface	XL2012
--	--------

Pin Configurations

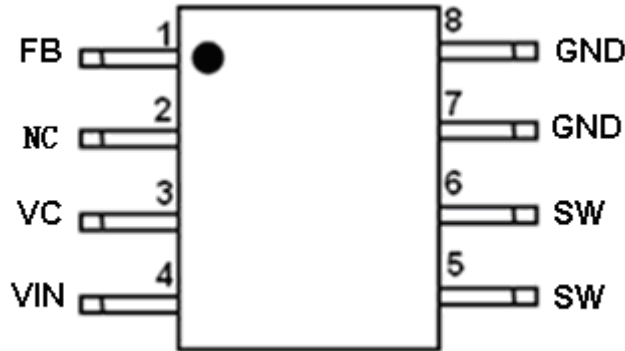

Figure2. Pin Configuration of XL2012 (Top View)

Table 1 Pin Description

Pin Number	Pin Name	Description
1	FB	Feedback Pin (FB). The feedback threshold voltage is 5V.
2	NC	No Connected.
3	VC	Internal Voltage Regulator Bypass Capacity. In typical system application, The VC pin connect a 1uf capacity to VIN.
4	VIN	Supply Voltage Input Pin. XL2012 operates from 8V to 40V DC voltage. Bypass Vin to GND with a suitably large capacitor to eliminate noise on the input.
5,6	SW	Power Switch Output Pin (SW). SW is the switch node that supplies power to the output.
7,8	GND	Ground Pin. Care must be taken in layout. This pin should be placed outside of the schottky diode to output capacitor ground path to prevent switching current spikes from inducing voltage noise into XL2012.



5V/2.4A 150KHz 40V Buck DC to DC Converter For USB Interface XL2012

Function Block

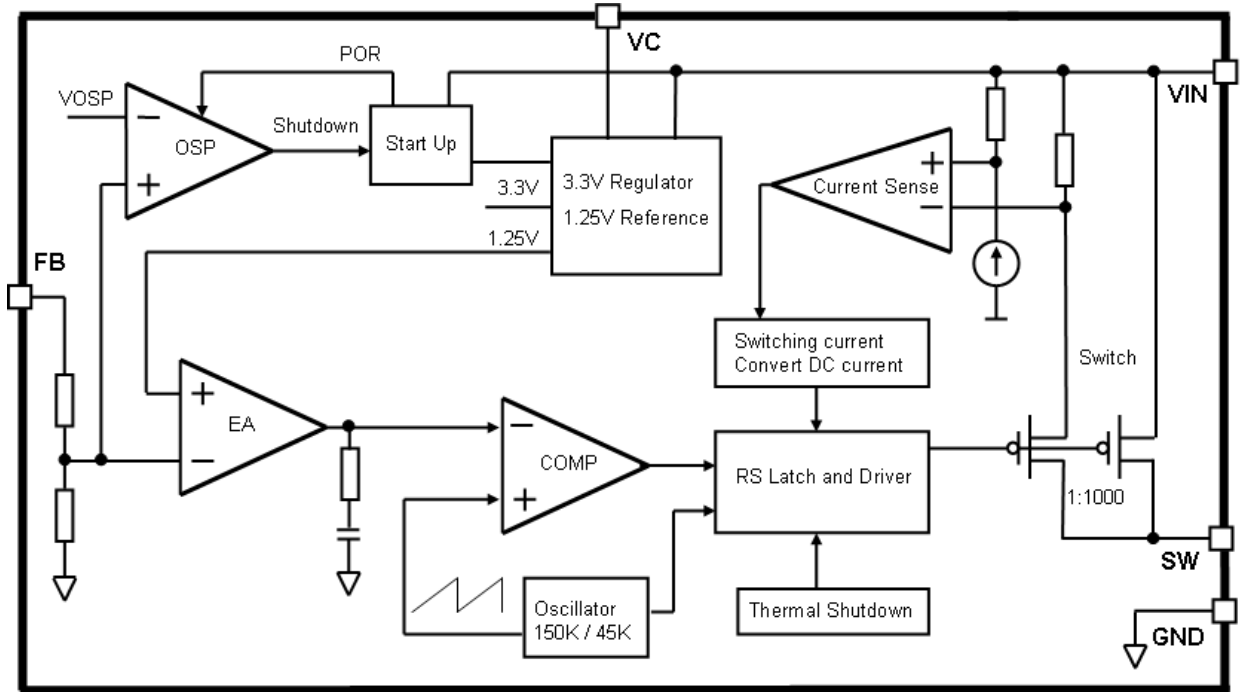

Figure3. Function Block Diagram of XL2012

Typical Application Circuit

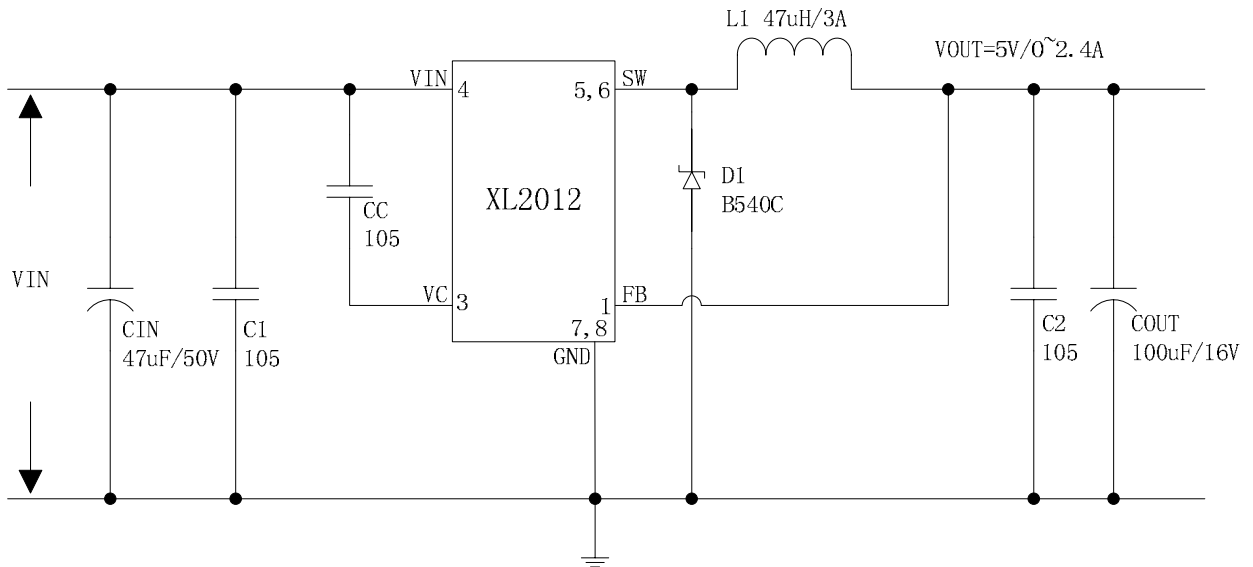

Figure4. XL2012 Typical Application Circuit (VIN=8V~40V, VOUT=5V/2.4A)



5V/2.4A 150KHz 40V Buck DC to DC Converter For USB Interface	XL2012
--	--------

Ordering Information

Order Information	Marking ID	Package Type	Packing Type Supplied As
XL2012E1	XL2012E1	SOP8L	2500 Units on Tape & Reel

XLSEMI Pb-free products, as designated with “E1” suffix in the par number, are RoHS compliant.

Absolute Maximum Ratings (Note1)

Parameter	Symbol	Value	Unit
Input Voltage	V _{in}	-0.3 to 45	V
Feedback Pin Voltage	V _{FB}	-0.3 to V _{in}	V
Output Switch Pin Voltage	V _{Output}	-0.3 to V _{in}	V
Power Dissipation	P _D	Internally limited	mW
Thermal Resistance (SOP8L) (Junction to Ambient, No Heatsink, Free Air)	R _{JA}	100	°C/W
Operating Junction Temperature	T _J	-40 to 125	°C
Storage Temperature	T _{STG}	-65 to 150	°C
Lead Temperature (Soldering, 10 sec)	T _{LEAD}	260	°C
ESD (HBM)		>2000	V

Note1: Stresses greater than those listed under Maximum Ratings may cause permanent damage to the device. This is a stress rating only and functional operation of the device at these or any other conditions above those indicated in the operation is not implied. Exposure to absolute maximum rating conditions for extended periods may affect reliability.



XL2012 Electrical Characteristics

$T_a = 25$;unless otherwise specified.

Symbol	Parameter	Test Condition	Min.	Typ.	Max.	Unit
<i>System parameters test circuit figure4</i>						
VFB	Feedback Voltage	$V_{in} = 8V \text{ to } 40V, V_{out}=5V$ $I_{load}=0.5A \text{ to } 2.4A$	4.9	5	5.1	V
Efficiency	η	$V_{in}=12V, V_{out}=5V$ $I_{out}=2.4A$	-	89	-	%

Electrical Characteristics (DC Parameters)

$V_{in} = 12V, GND=0V, V_{in}$ & GND parallel connect a $47\mu F/50V$ capacitor; $I_{out}=500mA, T_a = 25$; the others floating unless otherwise specified.

Parameters	Symbol	Test Condition	Min.	Typ.	Max.	Unit
Input operation voltage	V_{in}		8		40	V
Quiescent Supply Current	I_q	$V_{FB} = V_{in}$		4.7	10	mA
Output Short Supply Current	I_{osp}				5	mA
Oscillator Frequency	F_{osc}		128	150	173	KHz
Switch Current Limit	I_L	$V_{FB} = 0$		2.6		A
Output Power PMOS	R_{dson}	$V_{FB}=0V, V_{in}=12V,$ $I_{SW}=2.4A$		60	80	mohm



5V/2.4A 150KHz 40V Buck DC to DC Converter For USB Interface	XL2012
--	--------

Typical System Application (VOUT=5V/2.4A)

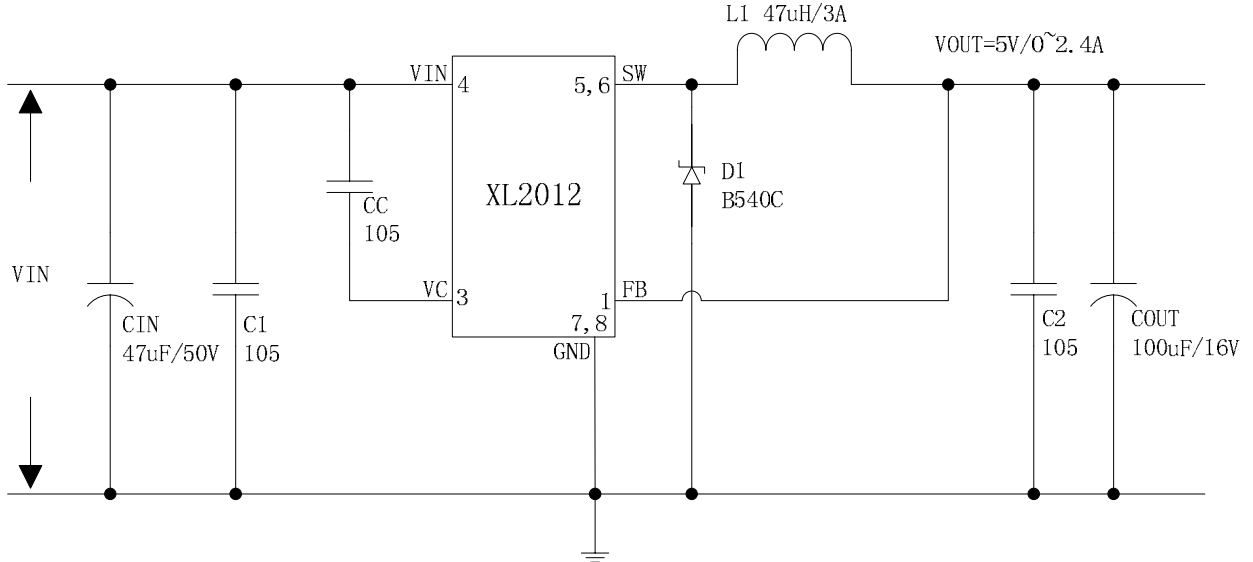

Figure5. XL2012 System Parameters Test Circuit (VIN=8V~40V, VOUT=5V/2.4A)

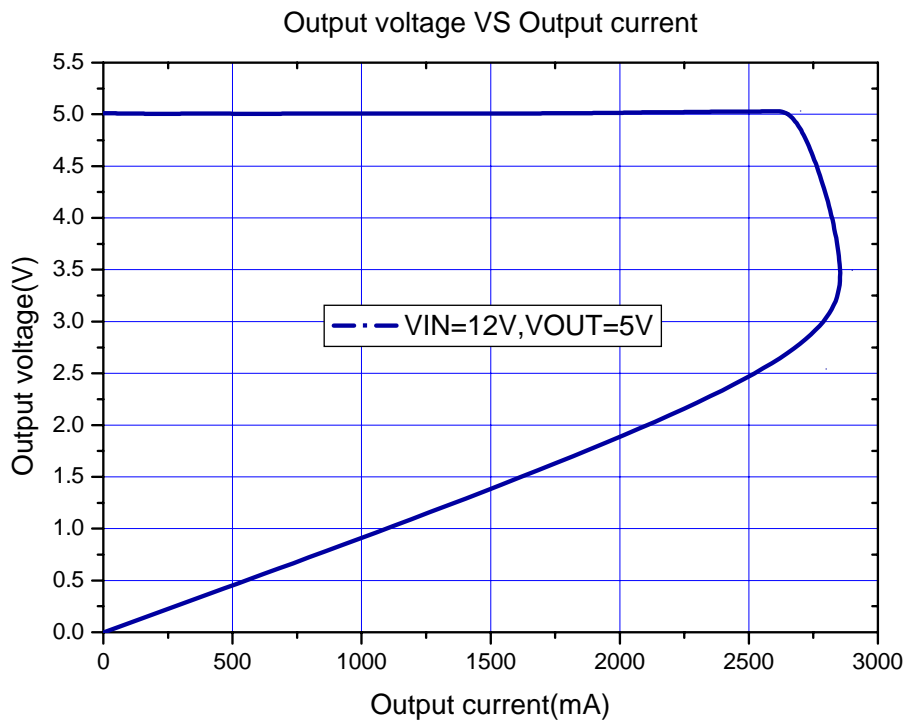

Figure6. XL2012 System Output Constant Current Curve



5V/2.4A 150KHz 40V Buck DC to DC Converter For USB Interface XL2012

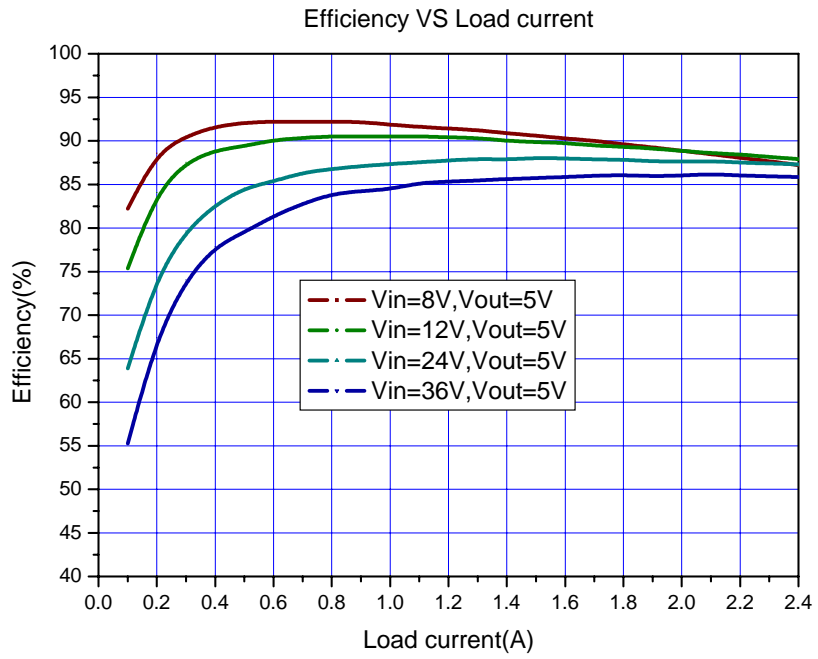

Figure7. XL2012 System Efficiency Curve



5V/2.4A 150KHz 40V Buck DC to DC Converter For USB Interface XL2012

Output short shutdown function description

The output short shutdown function is built in XL2012. The short protection circuit monitors the output voltage, whenever FB pin voltage is below 1.5V, the short circuit protection circuit is triggered, the converter will be shutdown, input current less than 5mA.

When the short fault is removed , if output load is floating, then converter will restart up, the output voltage will return to normal; if output load isn't floating, then converter must be power reset , the output voltage will comeback.

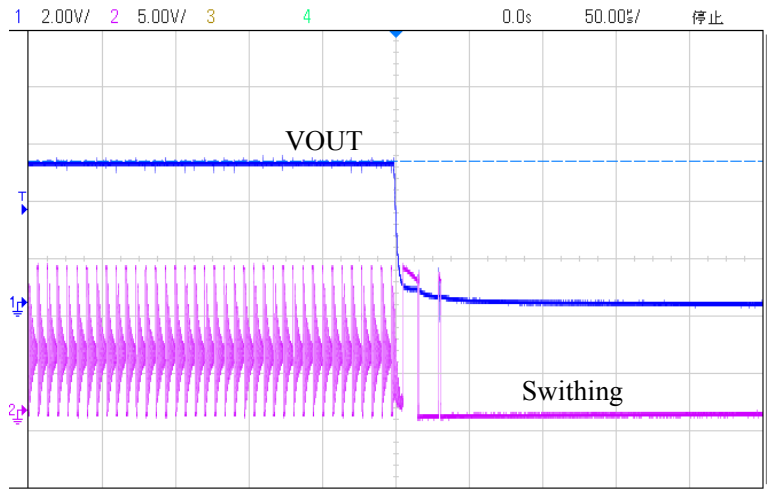

Figure8. The converter will be shutdown when output short happen.

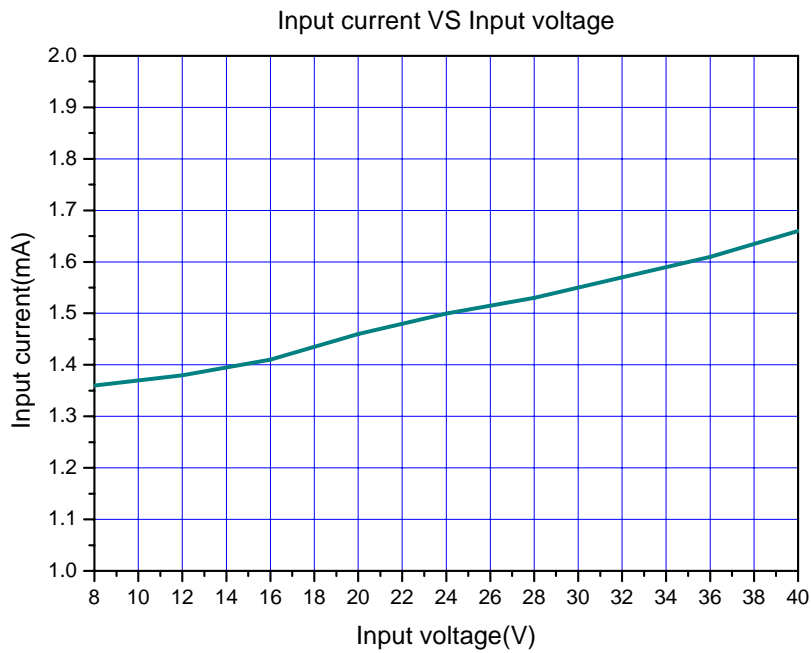

Figure9. The input current curve when output short happen.



5V/2.4A 150KHz 40V Buck DC to DC Converter For USB Interface	XL2012
--	--------

Package Information

SOP8 Package Mechanical Dimensions

