



SGM2028

500mA, Ultra-Low Dropout, Low Power, RF Linear Regulators

GENERAL DESCRIPTION

The SGM2028 is a low-power, low-noise, low-dropout, CMOS linear voltage regulator that operates from a 2.5V to 5.5V input voltage. It is the perfect choice for low voltage, low power applications. A low ground current makes this part attractive for battery operated power systems. The SGM2028 also offers ultra-low dropout voltage to prolong battery life in portable electronics. Systems requiring a quiet voltage source, such as RF applications, will benefit from the SGM2028's ultra-low output noise ($30\mu\text{V}_{\text{RMS}}$) and high PSRR. An external noise bypass capacitor connected to the device's BP pin can further reduce the noise level.

Other features include output current limit and thermal shutdown protection.

The SGM2028 is available in a Green SOT-23-5 package. It operates over an operating temperature range of -40°C to $+85^{\circ}\text{C}$.

FEATURES

- **500mA Guaranteed Output Current**
- **Ultra-Low Dropout Voltage**
- **Low Output Noise**
- **Thermal-Overload Protection**
- **Output Current Limit**
- **High PSRR: 73dB at 1kHz**
- **SGM2028-2.8, SGM2028-3.0 and SGM2028-ADJ: 110k Ω Pull Down Resistor at EN Pin**
- **SGM2028-3.3: No Pull Down Resistor at EN Pin**
- **Available Fixed Output Voltages: 2.8V, 3.0V and 3.3V**
- **Adjustable Output from 1.2V to 5.0V**
- **-40°C to $+85^{\circ}\text{C}$ Operating Temperature Range**
- **Available in a Green SOT-23-5 Package**

APPLICATIONS

Cellular Telephones
Cordless Telephones
PCMCIA Cards
Modems
MP3 Player
Hand-Held Instruments
Palmtop Computers
Electronic Planners
Portable/Battery-Powered Equipment

PACKAGE/ORDERING INFORMATION

MODEL	V _{OUT} (V)	PACKAGE DESCRIPTION	SPECIFIED TEMPERATURE RANGE	ORDERING NUMBER	PACKAGE MARKING	PACKING OPTION
SGM2028-2.8	2.8	SOT-23-5	-40°C to +85°C	SGM2028-2.8YN5G/TR	S58XX	Tape and Reel, 3000
SGM2028-3.0	3.0	SOT-23-5	-40°C to +85°C	SGM2028-3.0YN5G/TR	G68XX	Tape and Reel, 3000
SGM2028-3.3	3.3	SOT-23-5	-40°C to +85°C	SGM2028-3.3YN5G/TR	S55XX	Tape and Reel, 3000
SGM2028-ADJ	ADJ	SOT-23-5	-40°C to +85°C	SGM2028-ADJYN5G/TR	S4BXX	Tape and Reel, 3000

MARKING INFORMATION

NOTE: XX = Date Code.

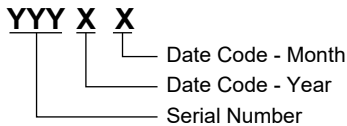

Green (RoHS & HSF): SG Micro Corp defines "Green" to mean Pb-Free (RoHS compatible) and free of halogen substances. If you have additional comments or questions, please contact your SGMICRO representative directly.

ABSOLUTE MAXIMUM RATINGS

IN to GND	-0.3V to 6V
Output Short-Circuit Duration.....	Infinite
EN to GND.....	-0.3V to (V _{IN} +0.3V)
OUT, BP/FB to GND.....	-0.3V to (V _{IN} + 0.3V)
Power Dissipation, P _D @ T _A = +25°C	
SOT-23-5.....	0.53W
Package Thermal Resistance	
SOT-23-5, θ _{JA}	235°C/W
Junction Temperature.....	+150°C
Storage Temperature Range.....	-65°C to +150°C
Lead Temperature (Soldering, 10s).....	+260°C
ESD Susceptibility	
HBM.....	4000V
MM.....	400V

RECOMMENDED OPERATING CONDITIONS

Input Voltage Range	2.5V to 5.5V
Operating Temperature Range	-40°C to +85°C

OVERSTRESS CAUTION

Stresses beyond those listed in Absolute Maximum Ratings may cause permanent damage to the device. Exposure to absolute maximum rating conditions for extended periods may affect reliability. Functional operation of the device at any conditions beyond those indicated in the Recommended Operating Conditions section is not implied.

ESD SENSITIVITY CAUTION

This integrated circuit can be damaged by ESD if you don't pay attention to ESD protection. SGMICRO recommends that all integrated circuits be handled with appropriate precautions. Failure to observe proper handling and installation procedures can cause damage. ESD damage can range from subtle performance degradation to complete device failure. Precision integrated circuits may be more susceptible to damage because very small parametric changes could cause the device not to meet its published specifications.

DISCLAIMER

SG Micro Corp reserves the right to make any change in circuit design, or specifications without prior notice.

PIN CONFIGURATION

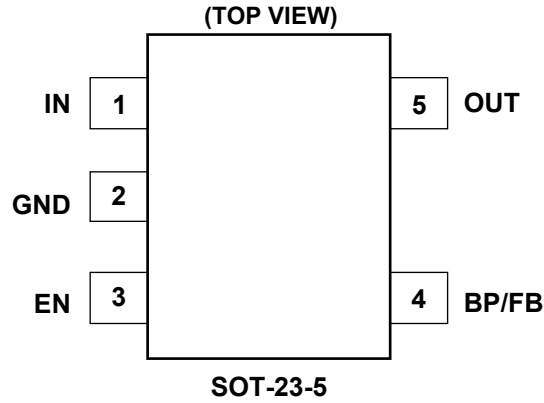

PIN DESCRIPTION

PIN	NAME	FUNCTION
1	IN	Regulator Input. Supply voltage can range from 2.5V to 5.5V. Bypass with a 1μF capacitor to GND.
2	GND	Ground.
3	EN	Shutdown Input. A logic low reduces the supply current to 10nA. Connect to IN for normal operation.
4	BP	Reference-Noise Bypass (fixed voltage version only). Bypass with a low-leakage 0.01μF ceramic capacitor for reduced noise at the output.
	FB	Feedback Pin (adjustable voltage version only). This is used to set the output voltage of the device.
5	OUT	Regulator Output.

ELECTRICAL CHARACTERISTICS

($V_{IN} = V_{OUT (NOMINAL)} + 0.5V$ or $2.5V$, whichever is greater, Full = $-40^{\circ}C$ to $+85^{\circ}C$. For SGM2028-ADJ, $V_{OUT} = 3.3V$, unless otherwise noted.)

PARAMETER	SYMBOL	CONDITIONS	TEMP	MIN	TYP	MAX	UNITS	
Input Voltage	V_{IN}		$+25^{\circ}C$	2.5		5.5	V	
Output Voltage Accuracy		$I_{OUT} = 0.1mA$	$+25^{\circ}C$	-3		+3	%	
Maximum Output Current ⁽¹⁾			$+25^{\circ}C$	500			mA	
Current Limit	I_{LIM}		$+25^{\circ}C$	510			mA	
Ground Pin Current	I_Q	No load, $V_{EN} = 2V$	$+25^{\circ}C$		115	220	μA	
Dropout Voltage ⁽²⁾		$I_{OUT} = 100mA$	$+25^{\circ}C$		54	90	mV	
		$I_{OUT} = 300mA$			162	270		
		$I_{OUT} = 500mA$			270	420		
Line Regulation	ΔV_{LNR}	$V_{IN} = V_{OUT} + 0.5V$ to $5.5V$, $I_{OUT} = 1mA$	$+25^{\circ}C$		0.02	0.095	%/V	
Load Regulation	ΔV_{LDR}	$I_{OUT} = 0.1mA$ to $500mA$, $C_{OUT} = 1\mu F$	$+25^{\circ}C$		0.0025	0.0075	%/mA	
Output Voltage Noise	e_n	$f = 10Hz$ to $100kHz$, $C_{BP} = 0.01\mu F$, $C_{OUT} = 10\mu F$	$+25^{\circ}C$		30		μV_{RMS}	
Power Supply Rejection Ratio	PSRR	$C_{BP} = 0.1\mu F$, $I_{OUT} = 50mA$, $C_{OUT} = 1\mu F$, $V_{IN} = V_{OUT} + 1V$	$f = 217Hz$	$+25^{\circ}C$		77		dB
			$f = 1kHz$	$+25^{\circ}C$		73		dB
Shutdown								
EN Input Threshold	V_{IH}	$V_{IN} = 2.5V$ to $5.5V$	Full	1.5			V	
	V_{IL}		Full			0.3		
Shutdown Supply Current	$I_{Q(SHDN)}$	$V_{EN} = 0.3V$	$+25^{\circ}C$		0.01		μA	
Shutdown Exit Delay ⁽³⁾		$C_{BP} = 0.01\mu F$, $C_{OUT} = 1\mu F$, no load	$+25^{\circ}C$		30		μs	
Thermal Protection								
Thermal Shutdown Temperature	T_{SHDN}				150		$^{\circ}C$	
Thermal Shutdown Hysteresis	ΔT_{SHDN}				15		$^{\circ}C$	

NOTES:

- Maximum output current is affected by PCB layout, size of metal trace, the thermal conduction path between metal layers and the environment of the system.
- The dropout voltage is defined as $V_{IN} - V_{OUT}$, when V_{OUT} is 100mV below the value of V_{OUT} for $V_{IN} = V_{OUT} + 0.5V$. (Only applicable for $V_{OUT} = +2.5V$ to $+5.0V$.)
- Time needed for V_{OUT} to reach 90% of final value.

TYPICAL APPLICATION CIRCUITS

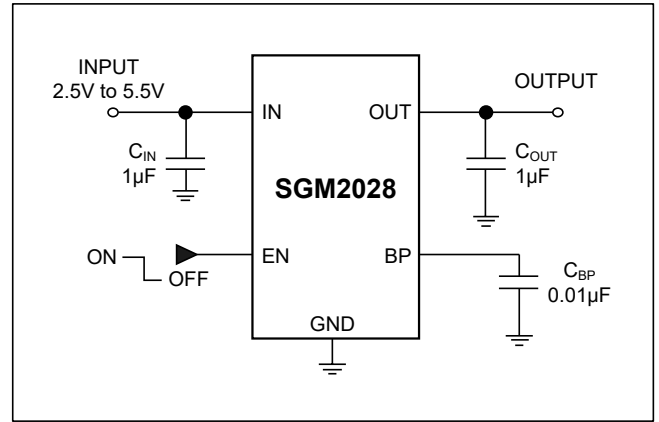
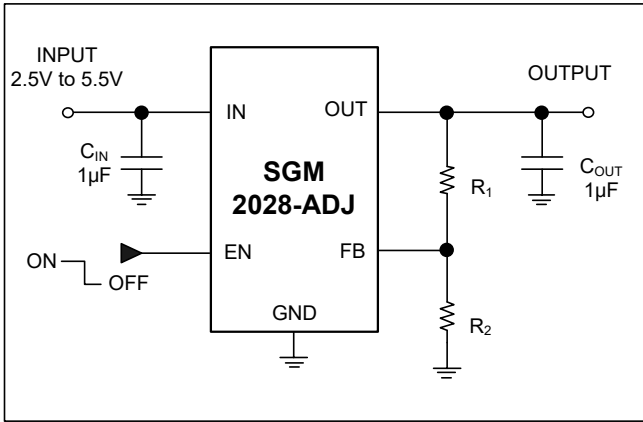

NOTE: Choose $R_2 = 47k\Omega$ to maintain a $26\mu A$ minimum load. Calculate the value for R_1 using the following equation:

$$R_1 = R_2 \times \left(\frac{V_{OUT}}{1.206V} - 1 \right)$$

TYPICAL PERFORMANCE CHARACTERISTICS

$V_{IN} = V_{OUT (NOMINAL)} + 0.5V$ or $2.5V$, whichever is greater, $C_{IN} = 1\mu F$, $C_{OUT} = 1\mu F$, $C_{BP} = 0.01\mu F$, $T_A = +25^\circ C$, unless otherwise noted.

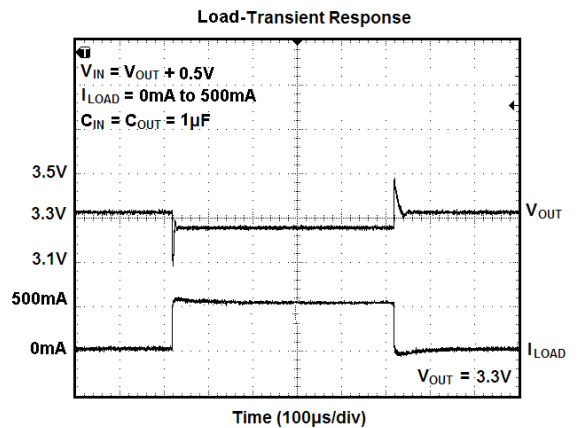
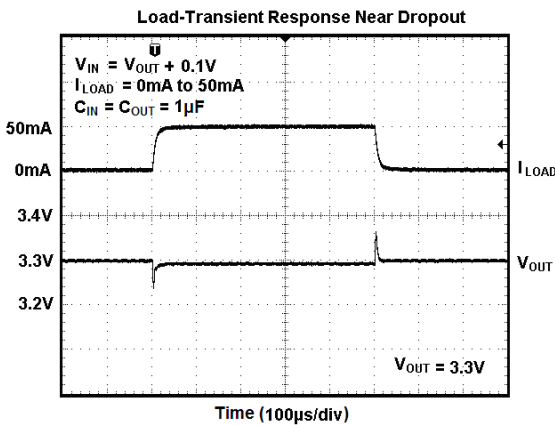
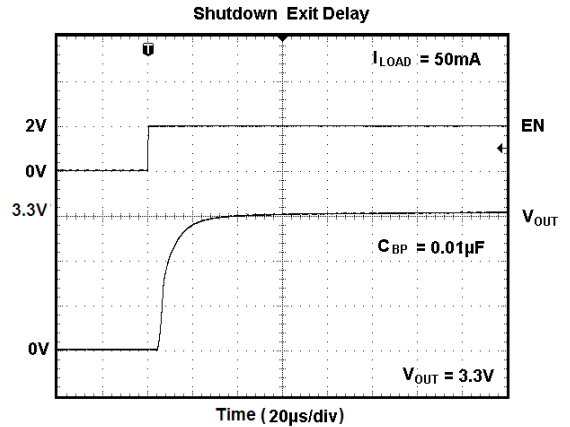
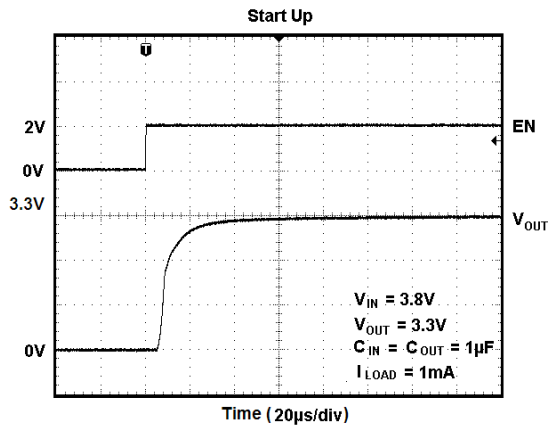
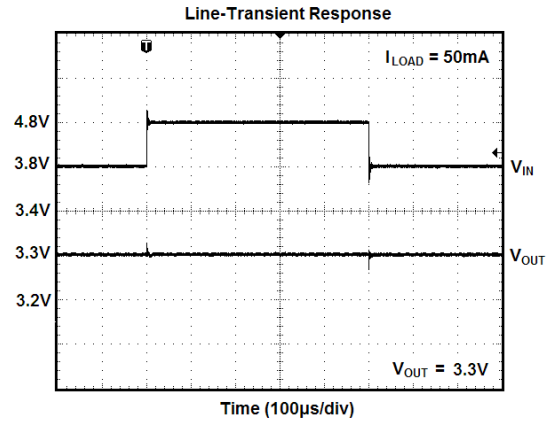
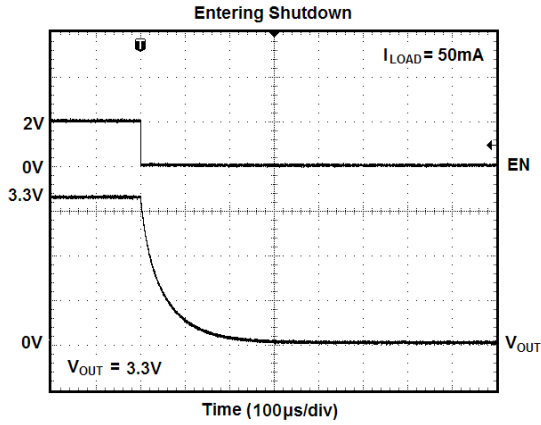

TYPICAL PERFORMANCE CHARACTERISTICS (continued)

$V_{IN} = V_{OUT} (NOMINAL) + 0.5V$ or $2.5V$, whichever is greater, $C_{IN} = 1\mu F$, $C_{OUT} = 1\mu F$, $C_{BP} = 0.01\mu F$, $T_A = +25^\circ C$, unless otherwise noted.

Power Supply Rejection Ratio vs. Frequency

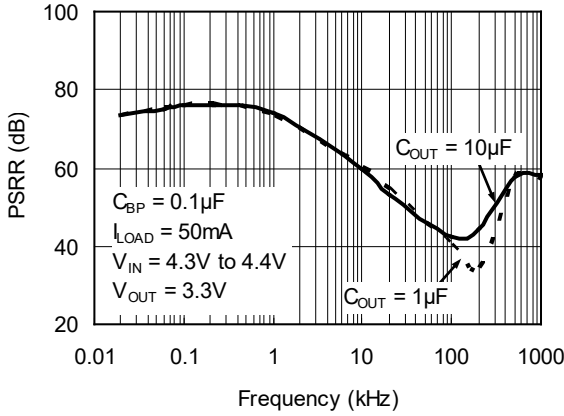

Dropout Voltage vs. Load Current

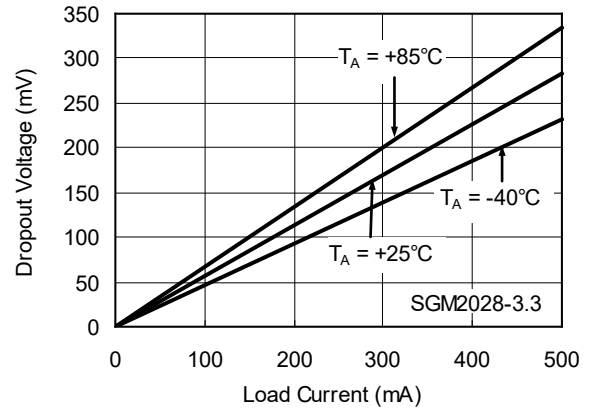

Output Voltage vs. Load Current

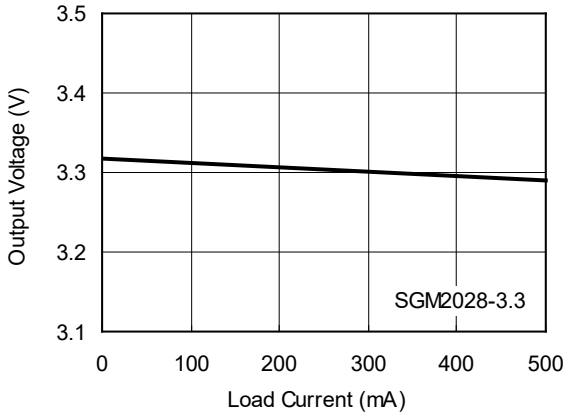

Output Voltage vs. Input Voltage

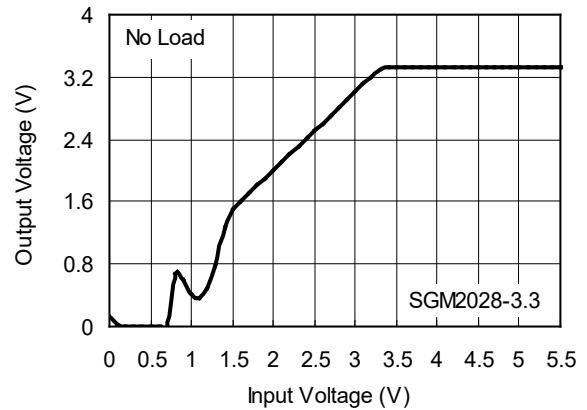

Ground Pin Current vs. Load Current

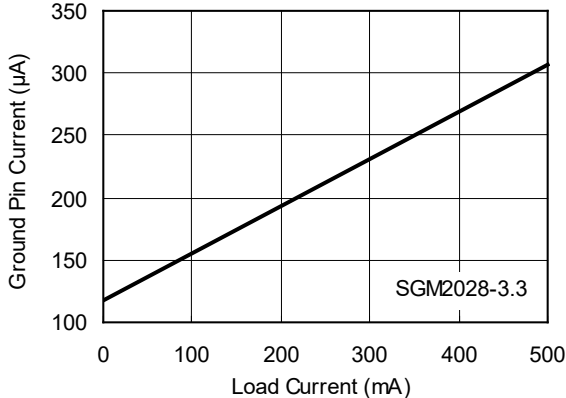

Normalized Output Voltage vs. Temperature

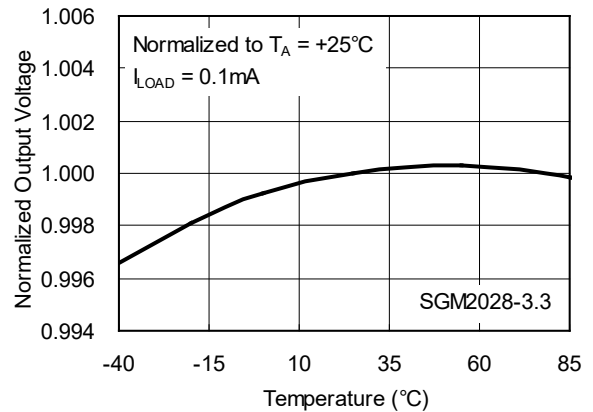

TYPICAL PERFORMANCE CHARACTERISTICS (continued)

$V_{IN} = V_{OUT (NOMINAL)} + 0.5V$ or $2.5V$, whichever is greater, $C_{IN} = 1\mu F$, $C_{OUT} = 1\mu F$, $C_{BP} = 0.01\mu F$, $T_A = +25^\circ C$, unless otherwise noted.

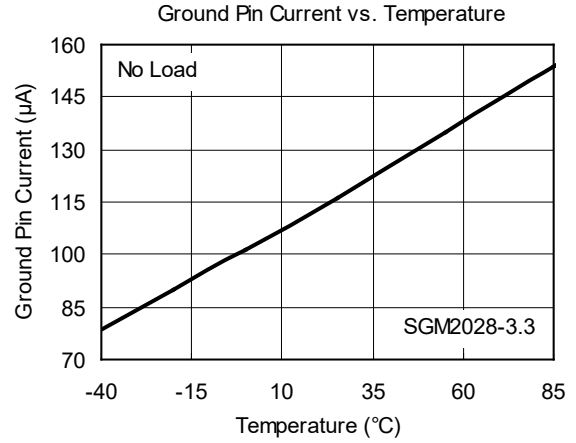
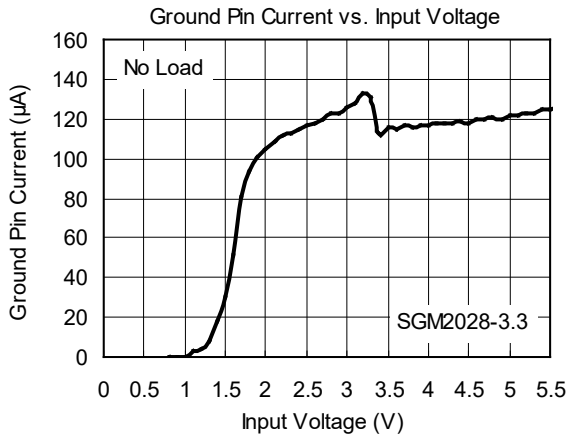

APPLICATION NOTE

When LDO is used in handheld products, attention must be paid to voltage spikes which could damage SGM2028. In such applications, voltage spikes will be generated at charger interface and V_{BUS} pin of USB interface when charger adapters and USB equipments are hot-plugged. Besides this, handheld products will be tested on the production line without battery. Test engineer will apply power from the connector pin which connects with positive pole of the battery. When external power supply is turned on suddenly, the voltage spikes will be generated at the battery connector. The voltage spikes will be very high, and it always exceeds the absolute maximum input voltage (6.0V) of LDO. In order to get robust design, design engineer needs to clear up this voltage spike. Zener diode is a cheap and effective solution to eliminate such voltage spike. For example, BZM55B5V6 is a 5.6V small package Zener diode which can be used to remove voltage spikes in cell phone designs. The schematic is shown below.

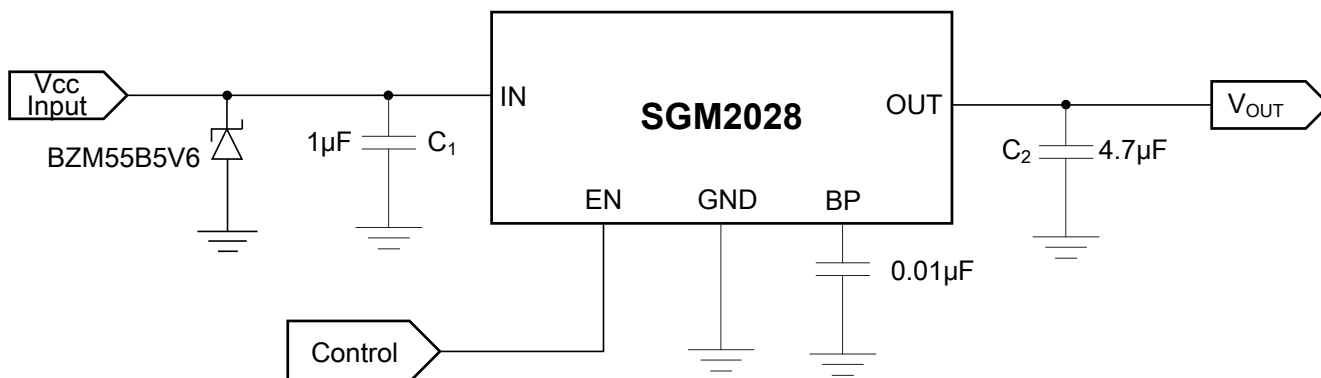

REVISION HISTORY

NOTE: Page numbers for previous revisions may differ from page numbers in the current version.

JUNE 2020 – REV.B.3 to REV.B.4	Page
Updated Absolute Maximum Ratings section.....	2
OCTOBER 2016 – REV.B.2 to REV.B.3	Page
Added SGM2028-3.0 version (110kΩ Pull Down Resistor at EN Pin).....	All
MAY 2016 – REV.B.1 to REV.B.2	Page
Changed Normalized Output Voltage vs. Temperature.....	7
DECEMBER 2013 – REV.B to REV.B.1	Page
Added 2.8V Output Voltage and ADJ.....	All
Changed Electrical Characteristics section	4
Changed Typical Application Circuits section	5
Changed Typical Performance Characteristics section	7, 8
JUNE 2013 – REV.A.4 to REV.B	Page
Deleted 2.8V Output Voltage	All

PACKAGE OUTLINE DIMENSIONS

SOT-23-5

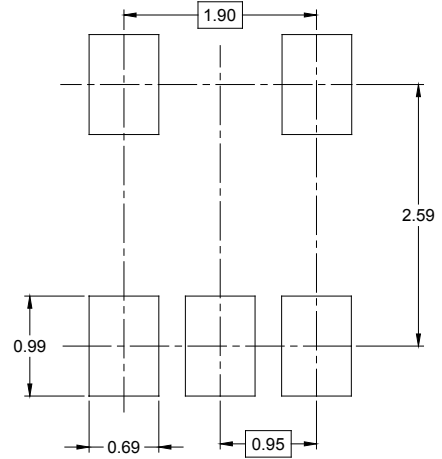

RECOMMENDED LAND PATTERN (Unit: mm)



Symbol	Dimensions In Millimeters		Dimensions In Inches	
	MIN	MAX	MIN	MAX
A	1.050	1.250	0.041	0.049
A1	0.000	0.100	0.000	0.004
A2	1.050	1.150	0.041	0.045
b	0.300	0.500	0.012	0.020
c	0.100	0.200	0.004	0.008
D	2.820	3.020	0.111	0.119
E	1.500	1.700	0.059	0.067
E1	2.650	2.950	0.104	0.116
e	0.950 BSC		0.037 BSC	
e1	1.900 BSC		0.075 BSC	
L	0.300	0.600	0.012	0.024
θ	0°	8°	0°	8°

TAPE AND REEL INFORMATION

REEL DIMENSIONS



TAPE DIMENSIONS



NOTE: The picture is only for reference. Please make the object as the standard.

KEY PARAMETER LIST OF TAPE AND REEL

Package Type	Reel Diameter	Reel Width W1 (mm)	A0 (mm)	B0 (mm)	K0 (mm)	P0 (mm)	P1 (mm)	P2 (mm)	W (mm)	Pin1 Quadrant
SOT-23-5	7"	9.5	3.20	3.20	1.40	4.0	4.0	2.0	8.0	Q3

000001

CARTON BOX DIMENSIONS



NOTE: The picture is only for reference. Please make the object as the standard.

KEY PARAMETER LIST OF CARTON BOX

Reel Type	Length (mm)	Width (mm)	Height (mm)	Pizza/Carton
7" (Option)	368	227	224	8
7"	442	410	224	18

DD0002