

GENERAL DESCRIPTION

The SGM2022 is a dual, low-power, low-dropout, CMOS linear voltage regulator. It operates from a 2.5V to 5.5V input voltage and delivers up to 250mA at each channel.

The SGM2022 is the perfect choice for low voltage, low power applications. The ground current is 190µA (both LDO's enabled and active) that makes this part attractive for battery operated power systems. The SGM2022 also offers low dropout voltage (250mV at 250mA output) to prolong battery life in portable electronics.

Separate enable pins control each individual LDO output. The EN function allows the output of each regulator to be turned off independently, resulting in greatly reduced power consumption. Other features include a 10nA logic-controlled shutdown mode, current limit and thermal shutdown protection.

The SGM2022 is available in a Green SOT-23-6 package. It operates over an ambient temperature range of -40°C to +85°C.

FEATURES

- **Highly Accurate: ±2%**
- **Ultra-Low Dropout Voltage:
250mV at 250mA Output**
- **190µA No-Load Supply Current**
- **Thermal-Overload Protection**
- **Output Current Limit**
- **10nA Logic-Controlled Shutdown**
- **Operating Temperature Range: -40°C to +85°C**
- **Available in a Green SOT-23-6 Package**

APPLICATIONS

- Cellular Telephones
- Cordless Telephones
- PCMCIA Cards
- Modems
- MP3 Player
- Hand-Held Instruments
- Palmtop Computers
- Wireless LAN
- Portable/Battery-Powered Equipment

TYPICAL APPLICATION

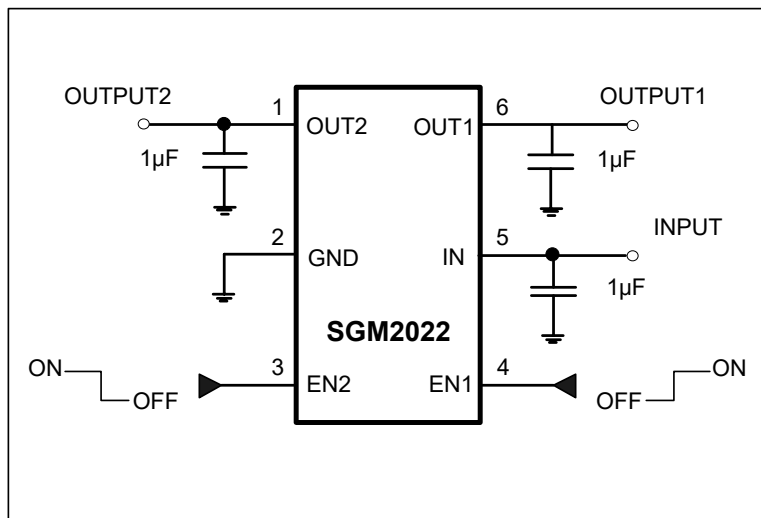

Figure 1. Typical Application Circuit

PACKAGE/ORDERING INFORMATION

ORDERING NUMBER	V _{OUT1}	V _{OUT2}	PACKAGE DESCRIPTION	SPECIFIED TEMPERATURE RANGE	PACKAGE MARKING	PACKING OPTION
SGM2022-AYN6/TR	2.8V	2.8V	SOT-23-6	-40°C to +85°C	2022A	Tape and Reel, 3000
SGM2022-CYN6/TR	2.8V	3.0V	SOT-23-6	-40°C to +85°C	2022C	Tape and Reel, 3000
SGM2022-DYN6/TR	2.8V	2.5V	SOT-23-6	-40°C to +85°C	2022D	Tape and Reel, 3000
SGM2022-EYN6/TR	2.8V	1.8V	SOT-23-6	-40°C to +85°C	2022E	Tape and Reel, 3000
SGM2022-GYN6/TR	2.5V	1.8V	SOT-23-6	-40°C to +85°C	2022G	Tape and Reel, 3000
SGM2022-HYN6/TR	3.3V	2.5V	SOT-23-6	-40°C to +85°C	2022H	Tape and Reel, 3000
SGM2022-IYN6/TR	3.3V	1.8V	SOT-23-6	-40°C to +85°C	2022I	Tape and Reel, 3000
SGM2022-KYN6/TR	3.0V	1.8V	SOT-23-6	-40°C to +85°C	2022K	Tape and Reel, 3000
SGM2022-MYN6/TR	2.8V	1.2V	SOT-23-6	-40°C to +85°C	2022M	Tape and Reel, 3000
SGM2022-NYN6/TR	2.8V	1.3V	SOT-23-6	-40°C to +85°C	2022N	Tape and Reel, 3000
SGM2022-OYN6/TR	2.8V	1.5V	SOT-23-6	-40°C to +85°C	2022O	Tape and Reel, 3000
SGM2022-PYN6/TR	1.5V	2.8V	SOT-23-6	-40°C to +85°C	2022P	Tape and Reel, 3000
SGM2022-QYN6/TR	2.5V	1.5V	SOT-23-6	-40°C to +85°C	2022Q	Tape and Reel, 3000
SGM2022-RYN6/TR	2.5V	2.8V	SOT-23-6	-40°C to +85°C	2022R	Tape and Reel, 3000
SGM2022-SYN6/TR	1.3V	2.8V	SOT-23-6	-40°C to +85°C	2022S	Tape and Reel, 3000
SGM2022-TYN6/TR	1.5V	3.3V	SOT-23-6	-40°C to +85°C	2022T	Tape and Reel, 3000
SGM2022-UYN6/TR	3.3V	3.0V	SOT-23-6	-40°C to +85°C	2022U	Tape and Reel, 3000
SGM2022-VYN6/TR	1.8V	3.3V	SOT-23-6	-40°C to +85°C	2022V	Tape and Reel, 3000
SGM2022-WYN6/TR	1.2V	2.8V	SOT-23-6	-40°C to +85°C	2022W	Tape and Reel, 3000
SGM2022-XYN6/TR	3.3V	2.8V	SOT-23-6	-40°C to +85°C	2022X	Tape and Reel, 3000
SGM2022-YYN6/TR	1.8V	2.8V	SOT-23-6	-40°C to +85°C	2022Y	Tape and Reel, 3000
SGM2022-ZYN6/TR	1.8V	1.8V	SOT-23-6	-40°C to +85°C	2022Z	Tape and Reel, 3000
SGM2022-AAYN6/TR	1.2V	1.8V	SOT-23-6	-40°C to +85°C	2022AA	Tape and Reel, 3000

Green (RoHS & HSF): SG Micro Corp defines "Green" to mean Pb-Free (RoHS compatible) and free of halogen substances. If you have additional comments or questions, please contact your SGMICRO representative directly.

ORDER NUMBER

SGM2022- X Y X / TR

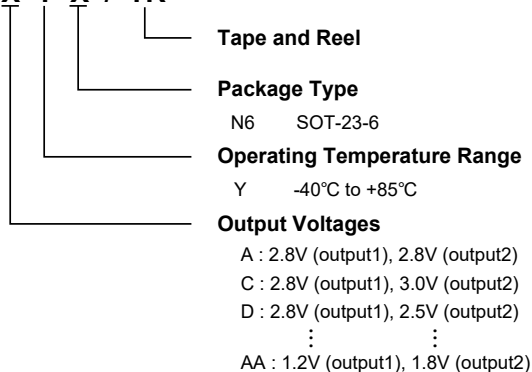

ABSOLUTE MAXIMUM RATINGS

IN to GND	-0.3V to 6V
Output Short-Circuit Duration.....	Infinite
EN to GND.....	-0.3V to V_{IN}
OUT to GND	-0.3V to ($V_{IN} + 0.3V$)
Power Dissipation, P_D @ $T_A = 25^\circ C$	
SOT-23-6	0.24W
Package Thermal Resistance	
SOT-23-6, θ_{JA}	250°C/W
Junction Temperature.....	+150°C
Storage Temperature Range	-65°C to +150°C
Lead Temperature (Soldering, 10s).....	+260°C
ESD	
HBM.....	4000V
MM.....	400V

RECOMMENDED OPERATING CONDITIONS

Operating Temperature Range	-40°C to +85°C
-----------------------------------	----------------

OVERSTRESS CAUTION

Stresses beyond those listed in Absolute Maximum Ratings may cause permanent damage to the device. Exposure to absolute maximum rating conditions for extended periods may affect reliability. Functional operation of the device at any conditions beyond those indicated in the Recommended Operating Conditions section is not implied.

ESD SENSITIVITY CAUTION

This integrated circuit can be damaged by ESD if you don't pay attention to ESD protection. SGMICRO recommends that all integrated circuits be handled with appropriate precautions. Failure to observe proper handling and installation procedures can cause damage. ESD damage can range from subtle performance degradation to complete device failure. Precision integrated circuits may be more susceptible to damage because very small parametric changes could cause the device not to meet its published specifications.

DISCLAIMER

SG Micro Corp reserves the right to make any change in circuit design, or specifications without prior notice.

PIN CONFIGURATION

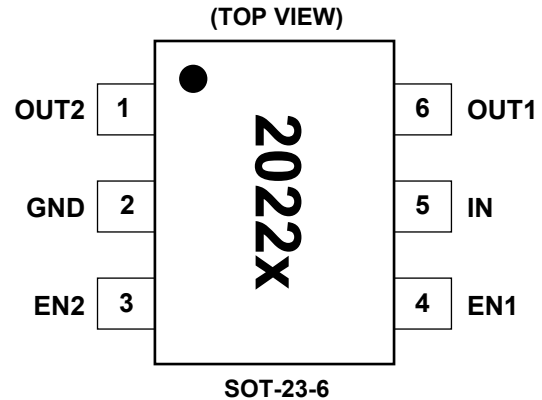

NOTE: The location of pin 1 on the 2022x is determined by orienting the package marking as shown.

PIN DESCRIPTION

PIN	NAME	FUNCTION
1	OUT2	Channel 2 Output Voltage.
2	GND	Common Ground.
3	EN2 ⁽¹⁾	On/Off Control 2. A logic low reduces the supply current to 10nA.
4	EN1 ⁽¹⁾	On/Off Control 1. A logic low reduces the supply current to 10nA.
5	IN	Supply Input.
6	OUT1	Channel 1 Output Voltage.

NOTE:

1. If EN1 and EN2 are both low, both regulators and the reference turn off.

ELECTRICAL CHARACTERISTICS

($V_{IN} = V_{OUT(NOMINAL)} + 0.5V$ or $2.5V$ (whichever is greater), $T_A = -40^{\circ}C$ to $+85^{\circ}C$, typical values are at $T_A = +25^{\circ}C$, for each LDO unless otherwise specified.)

PARAMETER	SYMBOL	CONDITIONS	MIN	TYP	MAX	UNITS
Input Voltage	V_{IN}		2.5		5.5	V
Output Voltage Accuracy		$I_{OUT} = 0.1mA$, $T_A = +25^{\circ}C$	-2		+2	%
Maximum Output Current ⁽³⁾			250			mA
Current Limit	I_{LIM}		310	500		mA
Ground Pin Current	I_Q	$EN = 2V$, both LDOs No Load		190	295	μA
Dropout Voltage ⁽¹⁾		$I_{OUT} = 1mA$		1		mV
		$I_{OUT} = 250mA$		250	350	
Line Regulation	$\frac{\Delta V_{OUT}}{\Delta V_{IN} \times V_{OUT}}$	$V_{IN} = 2.5V$ or $(V_{OUT} + 0.5V)$ to $5.5V$, $I_{OUT} = 1mA$		0.02	0.15	%/V
Load Regulation	$\frac{\Delta V_{OUT}}{\Delta I_{LOAD} \times V_{OUT}}$	$I_{OUT} = 0.1mA$ to $250mA$, $C_{OUT} = 1\mu F$		0.004	0.01	%/mA
Power Supply Rejection Rate	PSRR	$I_{OUT} = 50mA$, $C_{OUT} = 1\mu F$, $f = 100Hz$		71		dB
Shutdown						
EN Input Threshold	V_{IH}	$V_{IN} = 2.5V$ to $5.5V$		1.5		V
	V_{IL}					
EN Input Bias Current	$I_{B(SHDN)}$	$EN = 0V$ or $EN = 5.5V$	$T_A = +25^{\circ}C$	0.01	1	μA
			$T_A = +85^{\circ}C$	0.01		
Shutdown Supply Current	$I_{Q(SHDN)}$	$EN1 = EN2 = 0.4V$	$T_A = +25^{\circ}C$	0.01	1	μA
			$T_A = +85^{\circ}C$	0.01		
Shutdown Exit Delay ⁽²⁾		$C_{OUT} = 1\mu F$, No Load	$T_A = +25^{\circ}C$	20		μs
Thermal Protection						
Thermal Shutdown Temperature	T_{SHDN}			160		$^{\circ}C$
Thermal Shutdown Hysteresis	ΔT_{SHDN}			15		$^{\circ}C$

NOTES:

- The dropout voltage is defined as $V_{IN} - V_{OUT}$, when V_{OUT} is 100mV below the value of V_{OUT} for $V_{IN} = V_{OUT} + 0.5V$.
(Only applicable for $V_{OUT} = 2.5V$ to $3.3V$)
- Time needed for V_{OUT} to reach 95% of final value.
- Each channel provides 300mA of maximum output current when the condition of dissipating heat is good.

TYPICAL PERFORMANCE CHARACTERISTICS

$V_{IN} = V_{OUT (NOMINAL)} + 0.5V$ or $2.5V$ (whichever is greater), $C_{IN} = 1\mu F$, $C_{OUT} = 1\mu F$, $T_A = +25^\circ C$, unless otherwise noted.

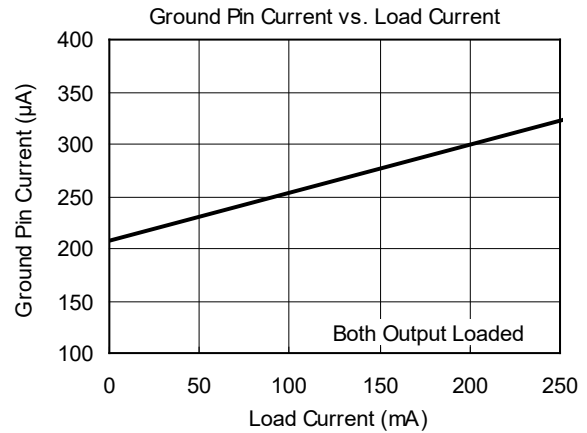
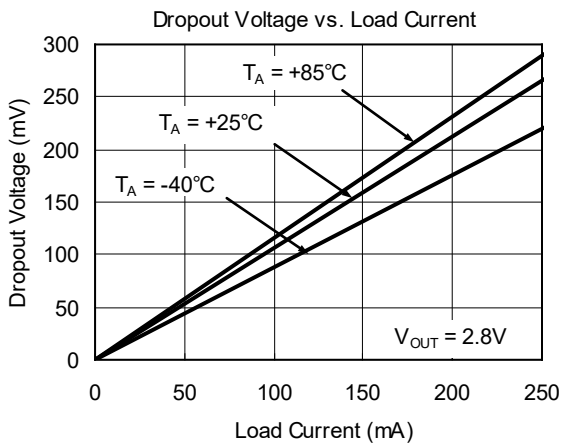
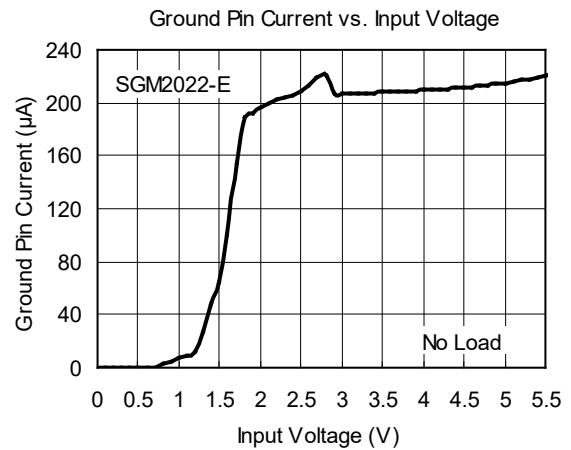
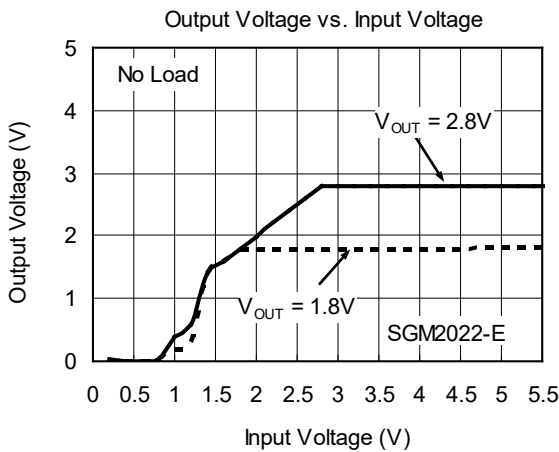
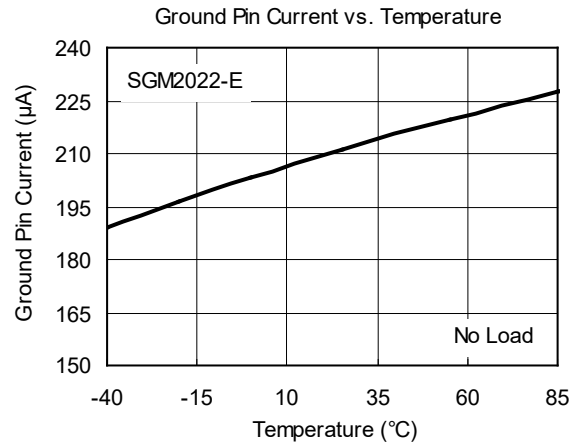
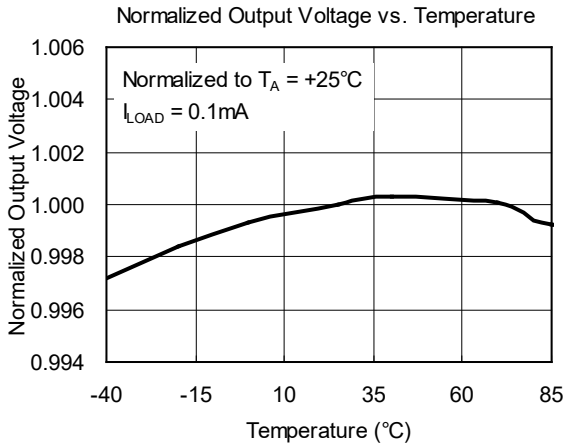

TYPICAL PERFORMANCE CHARACTERISTICS (continued)

$V_{IN} = V_{OUT} \text{ (NOMINAL)} + 0.5V$ or $2.5V$ (whichever is greater), $C_{IN} = 1\mu F$, $C_{OUT} = 1\mu F$, $T_A = +25^\circ C$, unless otherwise noted.

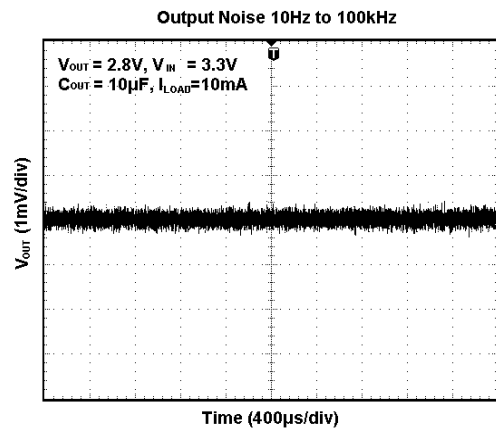
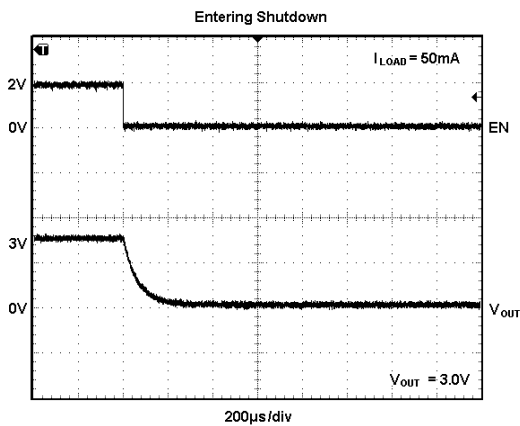
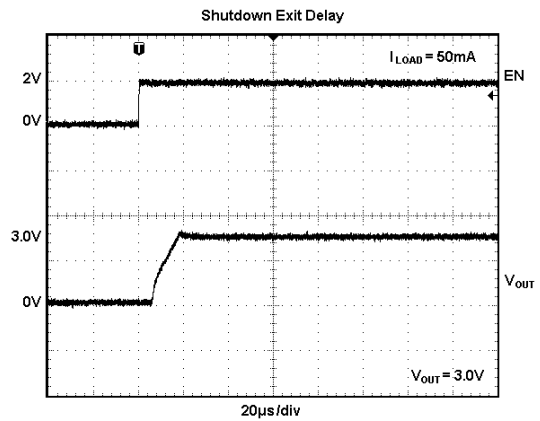
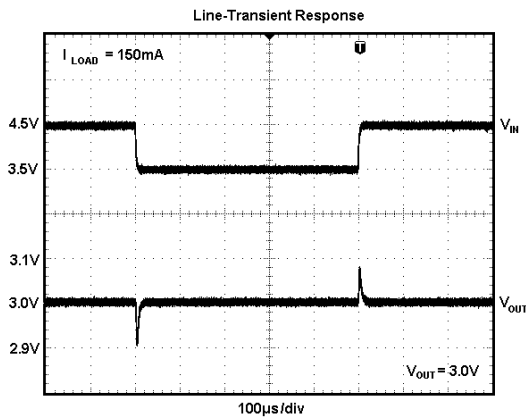
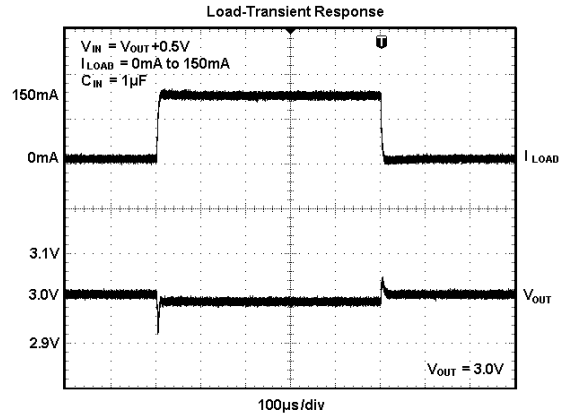
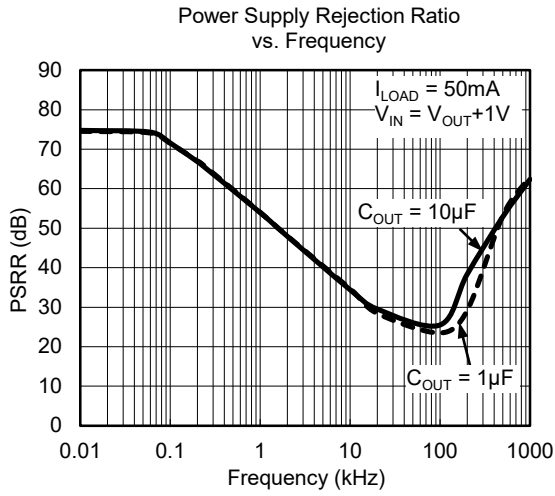

APPLICATION NOTE

The SGM2022 is designed specifically to work with low ESR ceramic output capacitor with space-saving and performance in consideration. Using a ceramic capacitor which is at least 1 μ F with ESR > 5m Ω on the SGM2022 output ensures stability. The SGM2022 still works well with output capacitor of other types due to the wide stable ESR range. The following figure shows the curves of allowable ESR range (5m Ω to 200m Ω) as a function of load current for various output capacitor values.

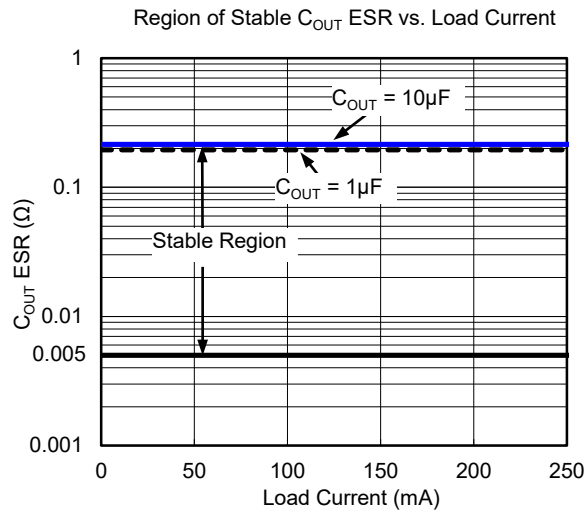

When LDO is used in handheld products, attention must be paid to voltage spikes which could damage SGM2022. In such applications, voltage spikes will be generated at charger interface and V_{BUS} pin of USB interface when charger adapters and USB equipments are hot-plugged. Besides this, handheld products will be tested on the production line without battery. Test engineer will apply power from the connector pin which connects with positive pole of the battery. When external power supply is turned on suddenly, the voltage spikes will be generated at the battery connector. The voltage spikes will be very high, and it always exceeds the absolute maximum input voltage (6.0V) of LDO. In order to get robust design, design engineer needs to clear up this voltage spike. Zener diode is a cheap and effective solution to eliminate such voltage spike. For example, BZM55B5V6 is a 5.6V small package Zener diode which can be used to remove voltage spikes in cell phone designs. The schematic is shown below.

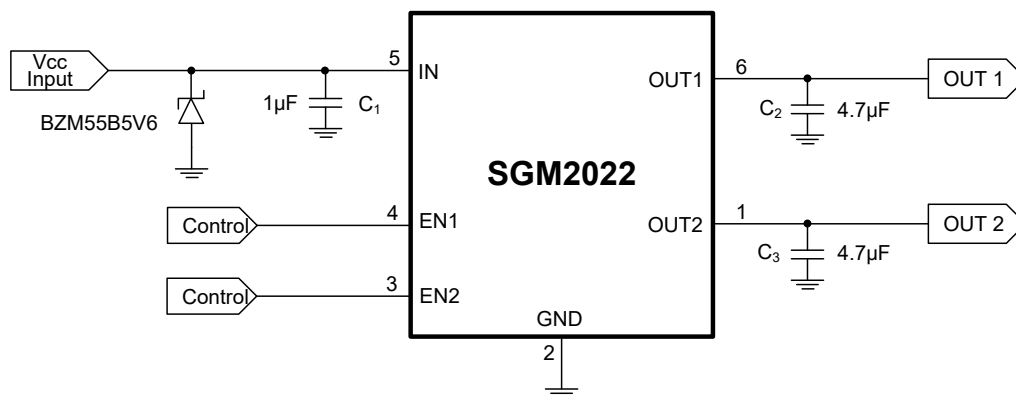

REVISION HISTORY

NOTE: Page numbers for previous revisions may differ from page numbers in the current version.

APRIL 2016 – REV.D to REV.D.1

Page

Changed Normalized Output Voltage vs. Temperature	6
---	---

PACKAGE OUTLINE DIMENSIONS

SOT-23-6

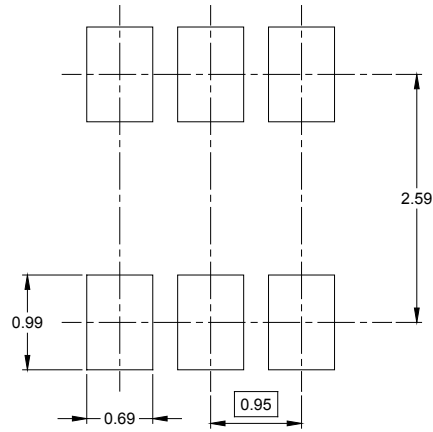
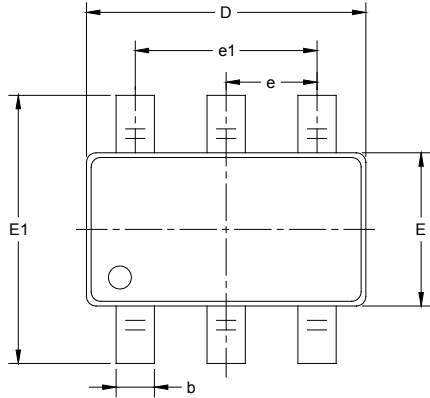

RECOMMENDED LAND PATTERN (Unit: mm)

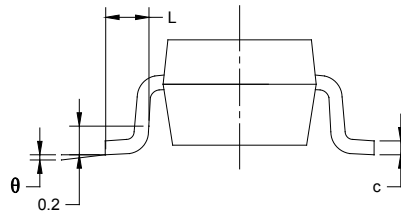
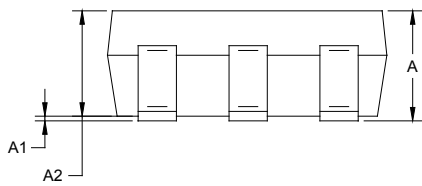

Symbol	Dimensions In Millimeters		Dimensions In Inches	
	MIN	MAX	MIN	MAX
A	1.050	1.250	0.041	0.049
A1	0.000	0.100	0.000	0.004
A2	1.050	1.150	0.041	0.045
b	0.300	0.500	0.012	0.020
c	0.100	0.200	0.004	0.008
D	2.820	3.020	0.111	0.119
E	1.500	1.700	0.059	0.067
E1	2.650	2.950	0.104	0.116
e	0.950 BSC		0.037 BSC	
e1	1.900 BSC		0.075 BSC	
L	0.300	0.600	0.012	0.024
θ	0°	8°	0°	8°

PACKAGE INFORMATION

TAPE AND REEL INFORMATION

REEL DIMENSIONS



TAPE DIMENSIONS



NOTE: The picture is only for reference. Please make the object as the standard.

KEY PARAMETER LIST OF TAPE AND REEL

Package Type	Reel Diameter	Reel Width W1 (mm)	A0 (mm)	B0 (mm)	K0 (mm)	P0 (mm)	P1 (mm)	P2 (mm)	W (mm)	Pin1 Quadrant
SOT-23-6	7"	9.5	3.17	3.23	1.37	4.0	4.0	2.0	8.0	Q3

DD0001

PACKAGE INFORMATION

CARTON BOX DIMENSIONS



NOTE: The picture is only for reference. Please make the object as the standard.

KEY PARAMETER LIST OF CARTON BOX

Reel Type	Length (mm)	Width (mm)	Height (mm)	Pizza/Carton
7" (Option)	368	227	224	8
7"	442	410	224	18

DD0002