

# WA

## Inductive Standard Displacement Transducers

Displacement probe



Plunger

### Special features

- Displacement probe and transducer with detachable plunger
- Good thermal stability in the event of temperature gradients
- Space-saving, compact design
- Pressure-resistant transducer for measuring displacement in hydraulic cylinders
- Acceleration resistance ensures long service life
- Option: high temperature version up to 150 °C, low temperature version up to -40 °C
- Output signal of your choice:  
80 mV/V  
0.5-10 V

Dimensions (in mm; 1 mm= 0.0397 inches)

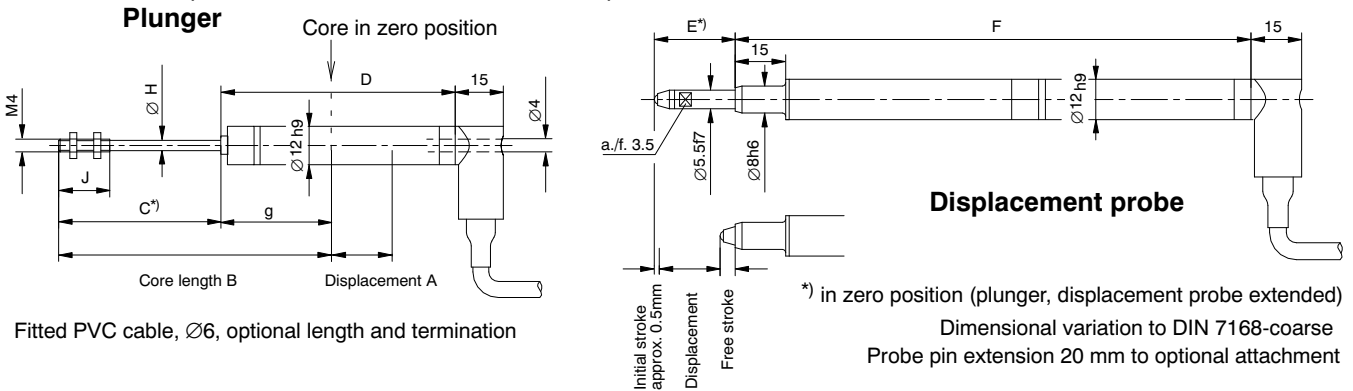

Fitted PVC cable, Ø6, optional length and termination

Measuring range	Plunger							Displacement probe		
	A	B	C	D	G	ØH	J	A	E	F
0...2 mm	2	75.5	40	69	35.5	1.2	15	2	14	130
0...10 mm	10	66	40	69	26 ± 0.5	3.7	16	10	14	130
0...20 mm	20	87	55	84	32 ± 0.5	3.7	16	20	24	170
0...50 mm	50	117	85	114	32 ± 0.5	3.7	16	50	54	230
0...100 mm	100	180	134	181.6	46 ± 10	3.7	16	100	104	372.6
0...200 mm	200	280	234	281.6	46 ± 10	3.7	16			
0...300 mm	300	380	334	381.6	46 ± 10	3.7	16			
0...500 mm	500	580	534	581.8	46 ± 10	3.7	16			

# Specifications

Type		WA2	WA10	WA20	WA50	WA100	WA200	WA300	WA500	
<b>Nominal displacement</b>	mm	0...2	0...10	0...20	0...50	0...100	0...200	0...300	0...500	
<b>Nominal sensitivity</b> Nominal output signal at nominal displacement with output unloaded	mV/V	80								
<b>Characteristic tolerance</b> Deviation of sensitivity from nominal sensitivity	%	±1								
<b>Zero point tolerance</b> with core in zero position	mV/V	±1							±8	
<b>Linearity deviation</b> Greatest deviation between start and end point (including hysteresis by reference to nominal sensitivity)	%	≤ ±0.2 to ≤ ±0.1								
<b>Nominal temperature range</b>	°C [°F]	-20...+80								
<b>Operating temperature range</b> Standard	°C [°F]	-25...+80 [-13...+176]								
Variant for high temperature	°C [°F]	-25...+150 [-13...+302]								
Variant for low temperature	°C [°F]	-40...+125 [-40...+257]								
<b>Effect of temperature</b> on zero signal in nominal temp. range per 10 K, by refer. to nominal sensitivity	%	< ±0.1								
<b>Effect of temperature</b> on output signal in nominal temp. range per 10 K, by refer. to actual value	%	< ±0.1								
<b>Input resistance</b>	Ω	100 ± 10 %							350 ± 10 %	
<b>Output resistance</b>	Ω	570 ± 10 %							680 ± 10 %	
<b>Nominal excitation voltage</b>	V <sub>rms</sub>	2.5								
<b>Operating range of the excitation voltage</b>	V <sub>rms</sub>	0.5...10								
<b>Carrier frequency,</b> Nominal range	kHz	4.8 ± 1 %								
Operating range	kHz	4.8 ± 8 %								
<b>Weight</b> of transducer body	g	54	56	57	68	104	147	190	276	
of plunger	g	4	6	7	9	13	20	28	42	
<b>Impact resistance</b> , test severity level to DIN IEC 68, Part 2-27; IEC 68-2-27-1987 Number of impacts (per direction)	-	1000								
Impact acceleration	m/s <sup>2</sup>	650								
Impact duration	ms	3								
Impact form	-	Half sine wave								
<b>Vibration resistance</b> , test severity level to DIN IEC 68, Part 2-6, IEC 68-2-6-1982 Frequency range	Hz	5 to 65								
Vibration acceleration	m/s <sup>2</sup>	150								
Stress duration (per direction)	h	0.5								
<b>Max. permissible plunger acceleration</b>	m/s <sup>2</sup>	2500								
	m/s <sup>2</sup>	<b>Probe version</b>					<b>Unfixed plunger version</b>			
<b>Service life, typically</b>		10 million stress cycles					-			
<b>Spring constant</b>	N/mm	0.116				0.063		-		
<b>Spring force in zero position (for 1mm initial stroke) approx.</b>	N	2.4				2		-		
<b>Spring force in final position (nom. displ.) appr.</b>	N	2.7	3.6	4.7	8.2	8.3	-			
<b>Max. permissible probe tip acceleration</b>	m/s <sup>2</sup>	170		140	95	45	-			
<b>Probe tip cut-off frequency for 1 mm stroke appr.</b>	Hz	60		55	45	30	-			
<b>Probe tip cut-off frequency at nominal displacement</b>	Hz	18		10	5	3	-			
<b>Degree of protection acc. to EN 60 529</b> for transducer duct and core channel	-	IP67 (depending on connection piece)								
<b>Max. permissible pressure</b> (increasing load)	bar	350								
<b>Overload limit</b> (to VDI/VDE 2600, Sheet 4)	bar	450								
<b>Destructive range</b> (to VDI/VDE 2600, Sheet 4)	bar	> 500								

## Specifications WA electronics

Type		WA2	WA10	WA20	WA50	WA100	WA200	WA300	WA500
<b>Nominal displacement</b>	mm	0...2	0...10	0...20	0...50	0...100	0...200	0...300	0...500
<b>Nominal output span<sup>1)</sup></b>	V	9.5 (0.5...10)							
<b>Output span tolerance<sup>1)</sup></b>	%	± 0.5							
<b>Linearity deviation<sup>1)</sup></b> Greatest deviation between start and end point (including hysteresis by reference to nominal sensitivity)	%	± 0.2							
<b>Nominal temperature range</b>	°C	-20...+60							
<b>Operating temperature range</b>	°C	-20...+70							
<b>Effect of temperature<sup>1)</sup></b> on zero signal in nominal temperature range per 10 K, by reference to nominal sensitivity	%	≤ ± 0.15; typically < ± 0.10							
<b>Effect of temperature<sup>1)</sup></b> on output signal in nominal temperature range per 10 K, by reference to actual value	%	≤ ± 0.15; typically < ± 0.10							
<b>Supply voltage</b>	V	15...30							
<b>Dependence of the nominal (rated) output range from the supply voltage, typically</b> (in the supply voltage range)	%	0.03							
<b>Burden in the output</b>	kΩ	≥ 10							
<b>Current consumption</b>	mA	45 (typically 26)							
<b>Power consumption max.</b>	W	1.5							
<b>Cut-off frequency</b>	Hz	520 filter 4th order, Butterworth							
<b>Cable length between the transducer and the electronics</b>	m	3...20							
<b>Cable length between the electronics and the evaluator</b>	m	3...50							

<sup>1)</sup> specified for the complete measuring chain

## WA electronics



### Dimensions WA electronics

Length: 102 mm  
Width: 32 mm  
Depth: 13.5 mm

### WA electronics cable assignment

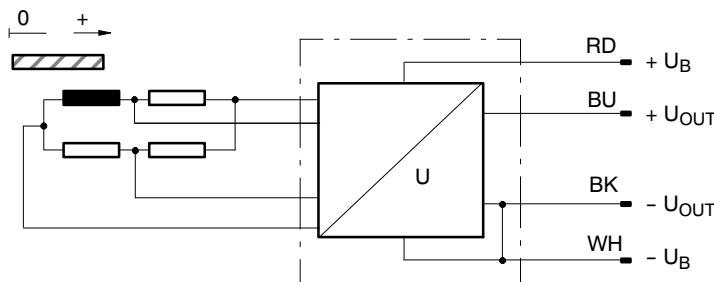

## Types of connection

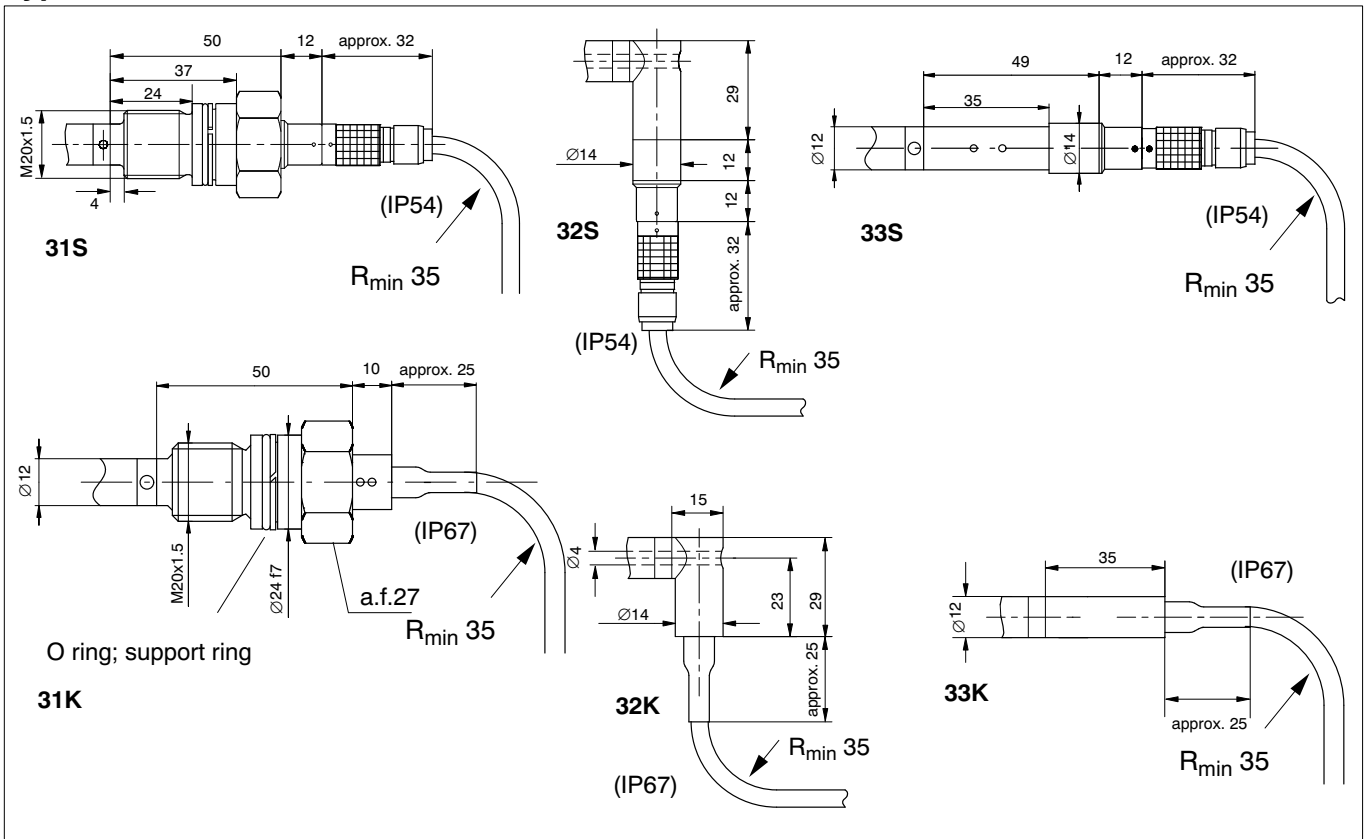

## Principle of measurement, wiring assignment

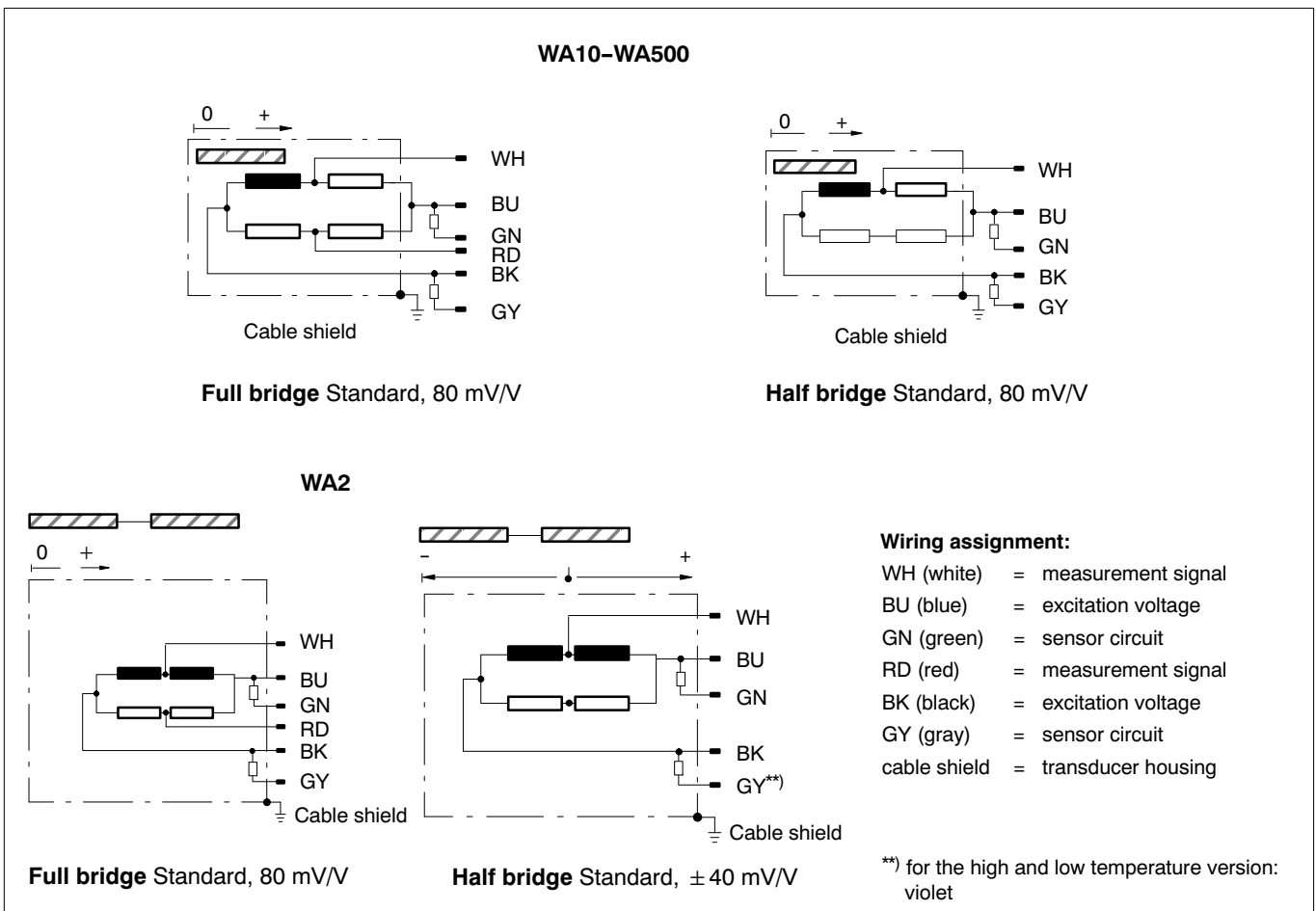

# Options for WA

Code	Option 1: version	Option 1: version	Option 1: version
L	Plunger, standard version	M	Plunger, high temperature version up to 150 °C
T	Displacement probe, standard version	U	Displacement probe, high temperature version up to 150 °C
		X	Displacement probe, low temperature version up to -40°C <sup>6)</sup>

Code	Option 2: measuring range [mm]	Option 1	
		T / U / X	L / M
002W	0...2	x	x
010W	0...10	x	x
020W	0...20	x	x
050W	0...50	x	x
100W	0...100	x	x
200W	0...200		x
300W	0...300		x
500W	0...500		x

Code	Option 3: type of connection
31K	M20x1.5; pressure resistant, fitted cable with straight output, IP67 (cable type K1, K2, K3, K4)
32K	Fitted cable, 90°, IP67 (cable type K1, K2, K3, K4)
33K	Fitted cable with straight output, IP67 (cable type K1, K2, K3, K4)
31S	M20x1.5; Lemo connector, IP54 (cable type S1, S2, S3, S4)
32S	Lemo connector, 90°, IP54 (cable type S1, S2, S3, S4)
33S	Lemo connector, straight IP54 (cable type S1, S2, S3, S4)

Code	Option 4: standard version (only with Option 1 - Code L,T)
K1	Fitted PVC cable; 3 m long
K2 <sup>1)</sup>	Fitted PVC cable; length as required, (>3 ... 300 m)
S1	Lemo connector, PVC cable; length 3 m
S2 <sup>1)</sup>	Lemo connector, PVC cable; length as required, (>3 ... 300 m)
Code	Option 4: high temperature version (only with Opt.1 - Code M,U) low temperature version (only with Opt.1 - Code X)
K3	PTFE cable, fitted, 3 m, max. 150 °C
K4 <sup>1)</sup>	PTFE cable, fitted, max. 150 °C, length as required, (>3 ... 20 m)
S3	Lemo connector, cable, 3 m, max. 150 °C
S4	Lemo connector, cable, max. 150 °C, length as required, (>3 ... 20 m)

Code	Option 5: termination
F1	Unterminated
D1 <sup>5)</sup>	Connector DB-15P
D2 <sup>5)</sup>	15-pin D connector wit integrated TEDS <sup>4)</sup>
M1 <sup>5)</sup>	Connector MS 3106PEMV

Code	Option 6: Linearity deviation
2	0.2 %
1 <sup>5)</sup>	0.1 %

Code	Option 7: Sensitivity
8	80 mV/V, full bridge, half bridge <sup>2)</sup>
2	0.5 - 10 V <sup>3)</sup> WA electronics, PVC cable to the evaluation device, 3 m

Order no.:

K-WA- [ ] - [ ] [ ] [ ] - [ ] [ ] [ ] - [ ] [ ] [ ] - [ ] [ ] [ ] - [ ] [ ] [ ] - [ ] [ ] [ ] - [ ] [ ] [ ] m - [ ] [ ] [ ] m

Typical order no.

K-WA- [T] - [0] [5] [0] [W] - [3] [2] [K] - [K] [2] - [F] [1] - [2] - [2] - [0] [2] [0] m - [5] [0] m

Devices with [ ] are rapidly available from stock in standard version at no extra charge.

Customized transducer cable length

Customized cable length between WA electronics and evaluation device

Components supplied: displacement transducer, test report, probe pin extension 20mm, Operating Manual

<sup>1)</sup> Customized transducer cable length  
• with Option 7 / Code 2: 3...20 m

<sup>3)</sup> Customized cable length between WA electronics and evaluation device; 3...50 m

<sup>5)</sup> Not with Option 7, Code 2 not with option 2, Code 010W

<sup>2)</sup> For the WA2: ± 40 mV/V

<sup>4)</sup> Only with option 4, Code K

<sup>6)</sup> A reduced load cycle capability has to be expected

## Standard displacement transducer WA

Version	Probe version	Plunger
Measuring range	Order no.	Order no.
0 ... 2 mm	1-WA/2MM-T	1-WA/2MM-L
0 ... 10 mm	1-WA/10MM-T	1-WA/10MM-L
0 ... 20 mm	1-WA/20MM-T	1-WA/20MM-L
0 ... 50 mm	1-WA/50MM-T	1-WA/50MM-L
0 ... 100 mm	1-WA/100MM-T	1-WA/100MM-L
0 ... 200 mm		1-WA/200MM-L
0 ... 300 mm		1-WA/300MM-L
0 ... 500 mm		1-WA/500MM-L

### Accessories:

Mounting set WS/ZB12

**1. Fitting suggestion**

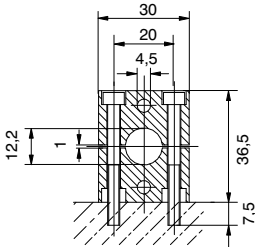

**2. Fitting suggestion**

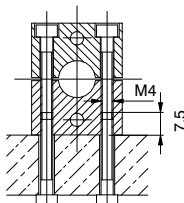

**3. Fitting suggestion**

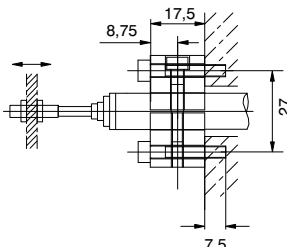

**WS/ZB12**  
 2 mounting blocks with countersink Km4  
 DIN 74  
 1 mounting block with thread M4

4 fillister-head screws M4x25, DIN 912  
 2 fillister-head screws M4x40, DIN 912

1 hexagonal-head bolt spanner a.f. 3

Operating temperature range from -40 °C...+80 °C

### Replacement parts:

- PVC cable as cable type S1, 3 m, with Lemo connector (male) (2-9268.0675 for 80 mV/V)
- PVC cable as cable type S2, any length (max. 300 m, 2-9268.0676 for 80 mV/V;  
max. 20 m with Option 7, Code 2)
- PTFE cable as cable type S3, 3 m; with Lemo connector (male) (2-9268.0766 for 80 mV/V)
- PTFE cable such as cable type S4, any length (max. 20 m, 2-9268.0767 for 80 mV/V)
- Lemo connector, detachable (6-pin, 3-3312.0126 for 80 mV/V)
- Lemo jack, detachable (6-pin, 3-3312.0235 for 80 mV/V)
- Measurement insert with carbide ball (3-6061.0003)

Modifications reserved.

All details describe our products in general form only. They are not to be understood as express warranty and do not constitute any liability whatsoever.

### Hottinger Baldwin Messtechnik GmbH

Im Tiefen See 45 · 64293 Darmstadt · Germany  
 Tel. +49 6151 803-0 · Fax: +49 6151 803-9100  
 Email: [info@hbm.com](mailto:info@hbm.com) · [www.hbm.com](http://www.hbm.com)

measure and predict with confidence

