

## MILITARY COTS VITA 62 COMPLIANT POWER SUPPLY

<b>155V - 425V</b> Continuous Input Voltage	<b>Input EMI Filtering</b>	<b>5</b> Outputs	<b>730W</b> Maximum Output Power	<b>90%</b> Typical Efficiency
--	----------------------------	---------------------	-------------------------------------	----------------------------------

**Operation: -40 °C to 85 °C (at wedge locks)**



### VPX Product Features

◆ **Outputs:**

- VS1: } +12V @50A= 600W
- VS2: }
- VS3: +5.0V @ 30A= 150W
- (AUX) +3.3V<sub>AUX</sub>@ 40A= 132W
- (AUX) +12V<sub>AUX</sub>@ 1A= 12W
- (AUX) -12V<sub>AUX</sub>@ 1A= 12W

- ◆ **Maximum Total Output Power: 730W**
- ◆ **Input EMI Filtering**
- ◆ **-40 °C to 85 °C Operating Temperature (at wedge locks)**
- ◆ **Over-current, over-voltage and over-temperature protection**
- ◆ **Current Sharing on +12V, +5.0V & +3.3V**
- ◆ **Remote Sense**
- ◆ **Standard VITA 62 Controls**
- ◆ **No Electrolytic Capacitors**

◆ **Compliance:**

- VITA 62**
- **MIL-STD-704**
- **MIL-STD-461**
- **MIL-STD-810G**
- **ESD Protection**
- **Shock**
- **Vibration**
- **Rapid Decompression**
- **Corrosion Resistance**
- **Fungus Resistance**
- **Altitude**
- **Humidity**



## BLOCK DIAGRAM FOR VPX-6U-DC270P-001

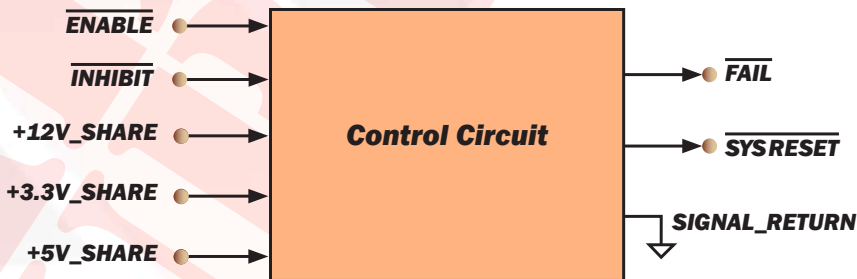
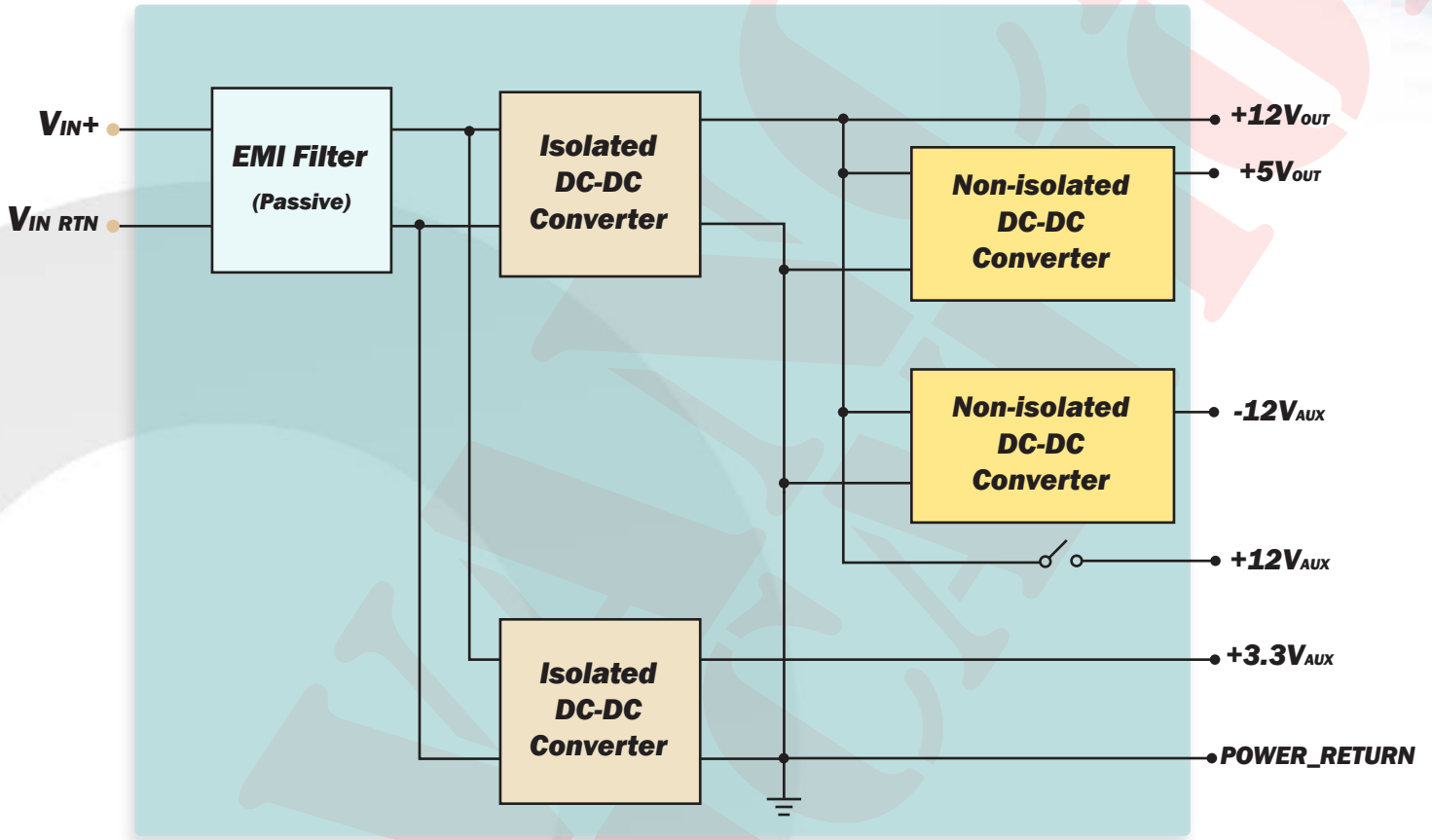

## VPX-6U-DC270P-001 INPUT CHARACTERISTICS

Parameter	Min.	Typ.	Max.	Units	Notes & Conditions
<b>ABSOLUTE MAXIMUM RATINGS</b>					
<b>Input Voltage</b>					
Non-Operating	-0.5		600	V	Continuous
Operating			425	V	Continuous
Operating Transient Protection			475	V	1s transient, square wave
<b>Isolation Voltage</b>					
Input to Output			4250	Vdc	
Input/Output to Case			2300	Vdc	
<b>Operating Temperature</b>	-40		85	°C	Wedge Lock Temperature
<b>Storage Temperature</b>	-55		105	°C	
<b>ELECTRICAL CHARACTERISTICS</b>					
<b>Input Voltage</b>					
Continuous	155	270	425	V	
Transient	155	270	475	V	475V transient for 1s
<b>Under-Voltage Lockout</b>					
Turn-On Input Voltage Threshold	146	150	154	V	
<b>FEATURE CHARACTERISTICS</b>					
<b>VITA 62 ON/OFF Control</b>					
					Control signals referenced to SIGNAL_RETURN
ENABLE* high-state Voltage	2	3.3		V	ENABLE* regards a no-connect as a high
ENABLE* low-state Voltage			0.8	V	
INHIBIT* high-state Voltage	2	3.3		V	INHIBIT* regards a no-connect as a high
INHIBIT* low-state Voltage			0.8	V	

## VPX-6U-DC270P-001 OUTPUT CHARACTERISTICS

Parameter	+12V	+5V	+3.3V <sub>AUX</sub>	+12V <sub>AUX</sub>	-12V <sub>AUX</sub>
<b>OUTPUT CHARACTERISTICS</b>					
<b>Output Voltage Set Point</b> See Note 1	<b>12V</b> (+/-1%)	<b>5V</b> (+/-1%)	<b>3.3V</b> (+/-1%)	<b>12V</b> (+/-1%)	<b>-12V</b> (+/-1%)
<b>Total Output Voltage Range</b> See Note 2	<b>12V</b> (+/-4%)	<b>5V</b> (+/-3%)	<b>3.3V</b> (+/-3%)	<b>12V</b> (+/-4%)	<b>-12V</b> (+/-3%)
<b>Output Voltage Ripple (pk-pk)</b> See Note 3	<b>80mV</b>	<b>50mV</b>	<b>80mV</b>	<b>80mV</b>	<b>50mV</b>
<b>Operating Current Range</b> Maximum Total Output Power = 730W	<b>0-50A</b>	<b>0-30A</b>	<b>0-40A</b>	<b>0-1A</b>	<b>0-1A</b>
<b>Over-Voltage Protection</b>	<b>15.0V</b>	<b>6.0V</b>	<b>4.1V</b>	<b>15.0V</b>	<b>NA</b>
<b>Current-Limit Inception</b>	<b>62.5A</b>	<b>40A</b>	<b>75A</b>	<b>2A</b>	<b>1.8A</b>
<b>Maximum Output Capacitance</b>	<b>10mF</b>	<b>10mF</b>	<b>25mF</b>	<b>1mF</b>	<b>10mF</b>
<b>MAXIMUM TOTAL OUTPUT POWER</b>	<b>730W</b>				

**Note 1:** 270V<sub>in</sub>, 50% load

**Note 2:** Over line, load, temperature

**Note 3:** Full Load, measured with 1µF capacitor and 10uF tantalum capacitor

**Maximum Total Output Power = 730W (Full Temperature Range)**

## PIN DESCRIPTIONS

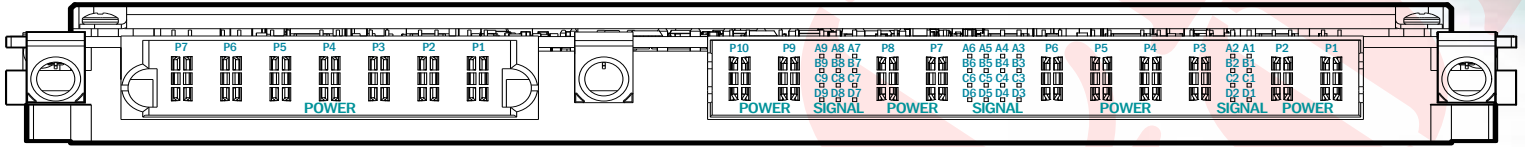

6U P0 Connector

6U P1 Connector

PIN	FUNCTION	DESCRIPTION
P7	+DC_IN	Vin+
P6	+DC_IN	Vin+
P5	-DC_IN	Vin-
P4	-DC_IN	Vin-
P3	Not currently used	
P2	Not currently used	
P1	CHASSIS	Chassis

PIN	FUNCTION	DESCRIPTION
P10	+12V_MAIN	+12V main output voltage, 50A rated
P9	+12V_MAIN	
A9	+12V_SENSE(+)	Should be connected to +12V_MAIN either remotely or at the connector
B9	+12V_SENSE(+)	
C9	+5V_SENSE(+)	Should be connected to +5V_MAIN either remotely or at the connector
D9	LED_DISABLE	Internally pulled up to 3.3V, connect to SIGNAL_RETURN to disable LED
A8	+12V_SENSE(-)	
B8	+12V_SENSE(-)	Should be connected to POWER_RETURN either remotely or at the connector
C8	Not currently used	
D8	+12V_SYNC	Startup synchronization for +12V_MAIN
A7	+12V_SHARE	Active current share differential pair for +12V_MAIN
B7	+5V_SHARE	Active current share differential pair for +5V_MAIN
C7	+3.3V_SHARE	Active current share for +3.3V_AUX
D7	SIGNAL_RETURN	Ground pin for control signals
P8	POWER_RETURN	Common output voltage return pin, 40A rated per pin
P7	POWER_RETURN	
A6	Not currently used	
B6	Not currently used	
C6	-12V_AUX	-12V auxiliary output voltage, 1A rated
D6	SYSRESET*	System Reset is actively low. Driven high when all outputs are within specification
A5	Not currently used	
B5	Not currently used	
C5	Not currently used	
D5	Not currently used	
A4	Not currently used	
B4	Not currently used	
C4	Not currently used	
D4	Not currently used	
A3	+5V_SYNC	Startup synchronization for +5V_MAIN
B3	+12V_AUX	+12V auxiliary output voltage, 1A rated
C3	Not currently used	
D3	Not currently used	
P6	+5V_MAIN	+5V main output voltage, 30A rated
P5	+5V_MAIN	
P4	POWER_RETURN	Common output voltage return pin, 40A rated per pin
P3	POWER_RETURN	
A2	Not currently used	
B2	FAIL*	When any of the output is not within specification, FAIL* signal will be driven low
C2	INHIBIT*	Input control signal as defined in VITA 62, referenced to SIGNAL_RETURN
D2	ENABLE*	Input control signal as defined in VITA 62, referenced to SIGNAL_RETURN
A1	+3.3V_SYNC	Startup synchronization for +3.3V_AUX
B1	Not currently used	
C1	Not currently used	
D1	Not currently used	
P2	+3.3V_AUX	+3.3V auxiliary output voltage, 40A rated
P1	POWER_RETURN	Common output voltage return pin, 40A rated per pin

## MECHANICAL DRAWINGS

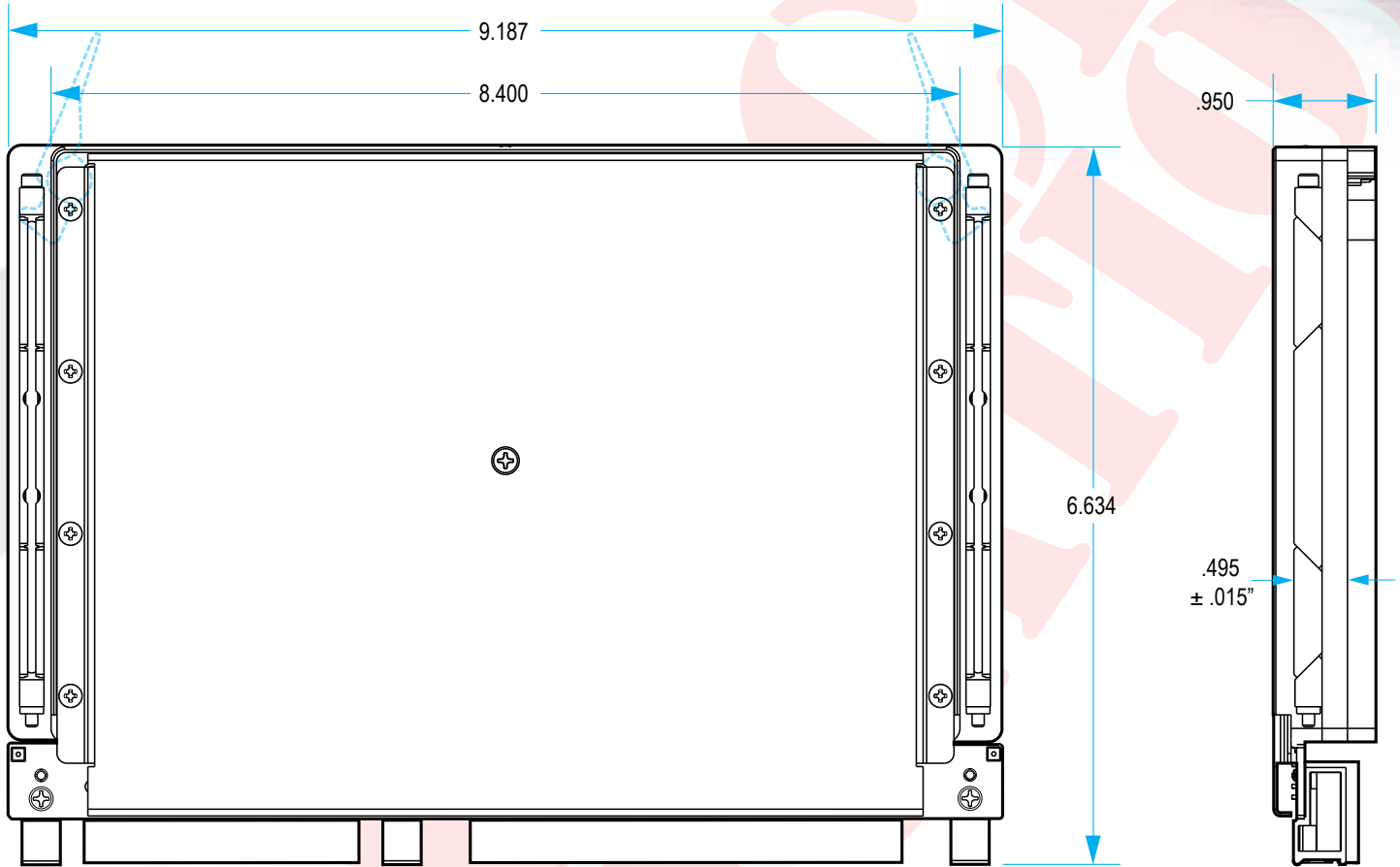

#### NOTES:

1. ALL DIMENSIONS IN INCHES

2. TOLERANCES: X.XX ±0.02 IN  
X.XXX ±0.010 IN

#### 3. CONNECTOR PART NUMBERS:

P0	TE Connectivity 6450843-6
	Foxconn HM811J3-B84F
P1	TE Connectivity 6450849-6
	Foxconn HM811L3-B84F

4. WEIGHT: 3.35 lbs (1.52 kg)

## APPLICATION NOTES

### CONTROL FEATURES

<b>ENABLE*</b>	Standard VITA 62 control signal. It is used to turn off all of the output voltages when it is high, including +3.3V_AUX. When it is pulled low to SIGNAL_RETURN, +3.3V_AUX will be turned on and the status of the other outputs will be dependent on the state of INHIBIT*. ENABLE* signal regards a no-connect as a high.
<b>INHIBIT*</b>	Standard VITA 62 control signal. It is used to turn off all the output voltages except +3.3V_AUX. When it is pulled low to SIGNAL_RETURN, VS1, VS2, VS3, +12V_AUX and -12V_AUX will be turned off. INHIBIT* signal regards a no-connect as a high. At power-on, if ENABLE* and INHIBIT* are configured to turn all outputs on, +3.3V_AUX will be powered up 100ms prior to when the other outputs are powered up.
<b>FAIL*</b>	FAIL* signal is used to indicate a failure has occurred. It will be pulled low when any of the outputs are outside the voltage specification. FAIL* is an active low open-drain signal. It is expected there will be a pull-up resistor on the backplane to 3.3V. A typical resistor value is 4.7kΩ
<b>SYSRESET*</b>	SYSRESET* signal is an output generated from the module. It is used to indicate that startup has completed. At power-on, SYSRESET* is pulled low. It will be high impedance when all outputs are within voltage specification. It will be pulled low if any failure has occurred or if the outputs are disabled by the user during operation. SYSRESET* signal is an active low open-drain signal. It is expected there will be a pull-up resistor on the backplane to 3.3V. A typical resistor value is 4.7kΩ.

### VITA 62 CONTROL STATES

ENABLE*	INHIBIT*	+3.3V_AUX	VS1, VS2, VS3, +12V_AUX, -12V_AUX
HIGH	HIGH	OFF	OFF
LOW	HIGH	ON	ON
HIGH	LOW	OFF	OFF
LOW	LOW	ON	OFF

### PARALLEL OPERATION

<b>+12V_MAIN +5V_MAIN &amp; +3.3V_AUX</b>	Active current sharing on +12V_MAIN, +5V_MAIN & +3.3V_AUX are supported with analog sharing schemes. To implement the current sharing function, SHARE pins, ENABLE*, INHIBIT* and SYNC pins should be connected together between all paralleled modules. These SHARE pins are referenced to POWER_RETURN. A clean ground plane is important, and ground drop between each module should be minimized.
<b>+12V_AUX &amp; -12V_AUX</b>	Active current sharing is not supported on +12V_AUX and -12V_AUX. However, both rails have OR'ing MOSFETs or OR'ing diodes implemented, so that they can still be operated in parallel. Total output current on these rails should not exceed the current rating of a single module.

## VPX MODULE QUALIFICATION (VITA 47 COMPLIANT)

Test Name	Method
Random Vibration	MIL-STD-810, 514.6 - Procedure I, Class V3
Shock	MIL-STD-810, 516.6 - Procedure I, VI, Class OS2
Altitude	MIL-STD-810, 500.5 - Procedure I, II, III
Fungus Resistance	MIL-STD-810, 508.6
Corrosion Resistance	ASTM G85, Annex A4
Humidity	MIL-STD-810, 507.5 - Procedure II
High Temperature	MIL-STD-810, 501.5 - Procedure I, II
Low Temperature	MIL-STD-810, 502.5 - Procedure I, II
Temperature Cycling	MIL-STD-202, 107 - Class C4
ESD	EN61000-4-2, Level 4; 15kV Air Discharge

## DC-DC CONVERTER AND FILTER SCREENING

Screening	Process Description	S-Grade	M-Grade
Baseplate Operating Temperature		-55 °C to +100 °C	-55 °C to +100 °C
Storage Temperature		-65 °C to +135 °C	-65 °C to +135 °C
Pre-Cap Inspection	IPC-610, Class III	Yes	Yes
Temperature Cycling	Method 1010, Condition B, 10 Cycles		Yes
Burn-In	100 °C Baseplate	12 Hours	96 Hours
Final Electrical Test	100%	25 °C	-55 °C, +25 °C, +100 °C
Final Visual Inspection	MIL-STD-2008	Yes	Yes



## ORDERING INFORMATION / PART NUMBERING

Series	Package Size (U)	Input Range	Mil Std Filtering	Output Voltage Combination Code	Packaging Options
<b>VPX</b>	<b>6U</b>	<b>DC270</b>	<b>P</b>	<b>001</b>	<b>Y<sub>1</sub>Y<sub>2</sub>Y<sub>3</sub></b>
<b>VPX</b>	<b>3U</b> <b>6U</b>	<b>DC28: 28V</b> <b>DC270: 270V</b>	<b>P: P - MIL-STD-704 (B-F)</b> <b>T: T - MIL-STD-704 A</b> <b>MIL-STD-1275 (B,D)</b> <b>DEF-STAN 61-5 (P6)/6</b>	<b>001: Standard product</b>	<b>Y<sub>1</sub>: Screening</b> <b>S - Standard (MCOTS)</b> <b>M - Military (MCOTS)</b> <b>Y<sub>2</sub>: Conformal Coating</b> <b>N - No Conformal Coating</b> <b>C - Conformal Coating</b> <b>Y<sub>3</sub>: TBD</b>

**Examples: VPX-6U-DC270P-001-SN**

### APPLICATION NOTES

A variety of application notes and technical white papers can be downloaded in PDF format from our website.

### PATENTS

SynQor holds the following U.S. patents, one or more of which apply to each product listed in this document. Additional patent applications may be pending or filed in the future.

5,999,417	6,222,742	6,545,890	6,577,109	6,594,159	6,731,520
6,894,468	6,896,526	6,927,987	7,050,309	7,072,190	7,085,146
7,119,524	7,269,034	7,272,021	7,272,023	7,558,083	7,564,702
7,765,687	7,787,261	8,023,290	8,149,597	8,493,751	8,644,027

### CONTACT SYNQOR FOR FURTHER INFORMATION AND TO ORDER:

Phone: \_\_\_\_\_ 978-849-0600  
 Toll Free: \_\_\_\_\_ 888-567-9596  
 Fax: \_\_\_\_\_ 978-849-0602  
 E-mail: \_\_\_\_\_ power@synqor.com  
 Web: \_\_\_\_\_ www.synqor.com  
 Address: \_\_\_\_\_ 155 Swanson Road  
 Boxborough, MA 01719 USA

### Warranty

SynQor offers a two (2) year limited warranty. Complete warranty information is listed on our website or is available upon request from SynQor.

Information furnished by SynQor is believed to be accurate and reliable. However, no responsibility is assumed by SynQor for its use, nor for any infringements of patents or other rights of third parties which may result from its use. No license is granted by implication or otherwise under any patent or patent rights of SynQor.