

DESCRIPTION

BLUEstreak is Unipower Corporation's new generation high density hot-swappable, modular Front-Ends and Rectifiers producing up to 2000 watts output power. There are 6 standard models with different output voltages and power levels. The modules are ultra-compact with power density up to 24 watts per cubic inch. The modules have automatic load sharing and active output ORing circuit so they can be hot-swapped while the system is operating. Using PMBus compliant serial communications, status and control data can be passed between a host system or power management unit and the module.

Front panel mounted LEDs indicate various status or fault conditions and +5V & 12V standby outputs are included. Operating temperature range is -40°C to +70°C.

FEATURES

- ◆ Up to 92% Efficiency
- ◆ 1U High: 1.6"
- ◆ -40°C to +70°C Operation
- ◆ Wide Range AC Input
- ◆ Up to 2000W Output
- ◆ >0.98 Power Factor
- ◆ Output Voltages: 12 to 54.4VDC
- ◆ Power Density to 24W/Cu. Inch
- ◆ Hot Swappable
- ◆ Integral Active Output ORing Circuit
- ◆ Class B EMI Filter
- ◆ LED Indicators
- ◆ PMBus Serial Communications
- ◆ Variable Speed Cooling Fans

TWO-YEAR WARRANTY

SAFETY STANDARDS

UL60950-1
 CSA22.2, No. 60950-1
 EN60950-1



FRONT-END / RECTIFIER MODULES

MAX. POWER	OUTPUT VOLTAGE	OUTPUT CURRENT	INPUT VOLTAGE ¹	INPUT CURRENT ²	MODEL NO.
2000W 1500W	54.4VDC	37.0A 28.0A	180-264VAC 85-132VAC	10A 14A	RBSR48/37
1500W	54.4VDC	28.0A	85-264VAC	14A/7.5A	RBSR48/28
2000W 1500W	48.0VDC	42.0A 31.0A	180-264VAC 85-132VAC	10A 14A	TBSR7000
1632W 1469W	27.2VDC	60.0A 54.0A	180-264VAC 85-132VAC	8.2A 13.5A	RBSR24/60
1469W	27.2VDC	54.0A	85-264VAC	13.5A/7.6A	RBSR24/54
1440W	24.0VDC	60A	85-264VAC	13.3A/7.3A	TBSR5000
1360W	13.6VDC	100.0A	85-264VAC	12.5A/7A	RBSR12/100
1200W	12.0VDC	100.0A	85-264	11A/6.5A	TBSR3000

Notes:

1. Models showing two output power levels with dual AC input ranges will operate over the full range from 85VAC to 264VAC, automatically limiting output current according to the actual input voltage range applied.
2. Input currents shown are nominal values at 120VAC/240VAC as appropriate.

MODULE ACCESSORIES

DESCRIPTION	PART NUMBER		
	UNIPOWER	TYCO	FCI
Mating Connector	355-3368-0000	6450372-1	51816-025
Evaluation Board	009-4045-0000		

4-BAY 19" SHELF SYSTEM ORDERING GUIDE

MAX. POWER	DESCRIPTION	MAX. CURRENT	MODEL NO.
8000W	Single Output Bus IEC60320-C20 AC Input	400A	TBSR1U4A
8000W	Single Output Bus Terminal Block AC Input	400A	TBSR1U4B
8000W	Dual Output Bus IEC60320-C20 AC Input	200A/200A	TBSR1U4C
8000W	Dual Output Bus Terminal Block AC Input	200A/200A	TBSR1U4D

Note: For detailed specifications of the 19" shelf system see separate datasheet.

SPECIFICATIONS

Typical at Nominal Line, Full Load and 25°C Unless Otherwise Noted.

INPUT

Voltage Range See Model Table
 Power Factor >0.98
 Total Harmonic Distortion, Max. 5%
 Frequency 47-63Hz
 Inrush Current Limiting, Max. 50A Peak
 EMI Filter, Conducted FCC20780 pt. 15J Curve B
 EN55022 Curve B
 Fast Transients EN61000-4-4
 Surges EN61000-4-5
 Remote Adjust 0 to +5V
 Input Protection Internal Fuse, 25A

OUTPUT

Current & Voltage See Table
 Output Power 1200-2000W
 Voltage Adjustment Range ¹
 48V / 54.4V 30-60V
 24V / 27.2V 15-30V
 12V / 13.6V 7.5-15V
 Standby Output ² +5V@1.8A
 +12V@0.8A
 Line & Load Regulation, Max. 0.3%
 Holdup Time 10msec.
 Overvoltage Protection Latch Off
 Filtering: Wideband Noise, 20MHz BW 200mV
 Current Limit ³ 105-115% Rated Current (Programmable)
 Efficiency (54.4VDC @ 2000W rated)
 100% Load to 91.6%
 75% Load to 92.0%
 40% Load to 91.0%

SAFETY STANDARDS UL60950-1, CSA22.2 No. 60950-1, EN60950-1

STATUS INDICATORS

STATUS Green LED
 FAULT Red LED

ALARM SIGNALS (open drain, TTL compatible)

ACOK AC present, 5V standby operating
 DCOK DC output within -10% of nominal
 TEMPOK Internal temperature within limits
 FANOK Fans running correctly

PMBus

Version Compliance 1.1

ENVIRONMENTAL

Operating Temp. Range ⁴ -20°C to +70°C
 Output Current Derating 2.5%/°C, 50°C to 70°C
 Storage Temp. Range -40°C to + 85°C
 Humidity 0% to 95%, Non-Condensing
 ESD Bellcore GR-1089-Core and EN61000-4-2
 MTBF, 35°C (Bellcore) 200,000 Hours
 Cooling Integral Ball Bearing Fans

PHYSICAL SPECIFICATIONS

Case Material Steel
 Case Dimensions, Inches (mm) 1.60 H x 4.00 W x 13.70 D
 (40.6 x 102 x 347.9)
 Weight 4.8 lbs. (2.2 kg.)

Notes:

1. When programmed via PMbus and may require adjusting DCOK and OVP settings.
2. Total standby power limited to 9.6W.
3. Subject to absolute power limit of 2000W + tolerance.
4. Startup at -40°C, but output is not enabled until internal temperature reaches -20°C.

OUTLINE DRAWING

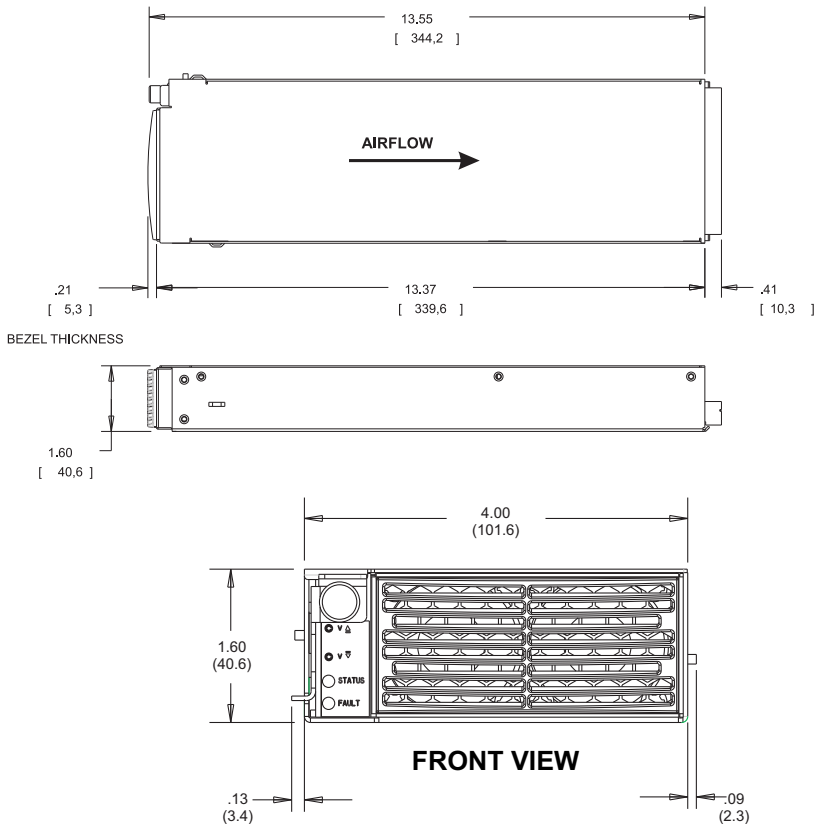

REAR VIEW (with connection details)

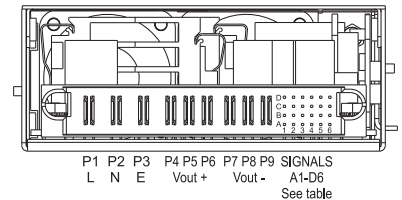

SIGNAL PIN CONNECTIONS			
PIN	FUNCTION	PIN	FUNCTION
A1	MODULE PRESENT	C1	Sense +Ve ⁴
A2	GA6	C2	Current Monitor ⁴
A3	GA3	C3	GA1
A4	Standby Return	C4	5V Standby ^{1,3}
A5	FANOK	C5	DCOK
A6	SMBALERT	C6	SCL
B1	Sense -Ve	D1	Remote Adjust ⁴
B2	Control	D2	Current Share ⁴
B3	GA2	D3	GA0
B4	Standby Return	D4	12V Standby ^{2,3}
B5	TEMPOK	D5	ACOK
B6	SDA	D6	ENABLE

NOTES:

1. Current rating of +5V standby is 1.8A.
2. Current rating of +12V standby is 0.8A.
3. Total standby consumption limited to 9.6W.
4. Referenced to -Ve Sense.

ALL DIMENSIONS IN INCHES (mm).

All specifications subject to change without notice.

FRONT PANEL INDICATORS & CONTROLS

LED INDICATORS

Green LED (top)

LED Status	Condition
ON	DCOK is TRUE
FLASHING	DCOK is FALSE - unit inhibited
OFF	DCOK is FALSE - unit not inhibited

Red LED (bottom)

LED Status	Condition	Possible causes
ON	DC output OFF	Temperature above/below allowed limits. OVP. Overcurrent or Short Circuit (DCOK goes FALSE). Processor Failure. (Green LED OFF).
FLASHING	DC output ON (warning)	Fans below expected speed. Temperature high/low. Output current close to maximum. Output on but DCOK FALSE. AC input voltage outside range.
OFF	DC output ON	

All possible conditions for the LEDs are shown opposite.

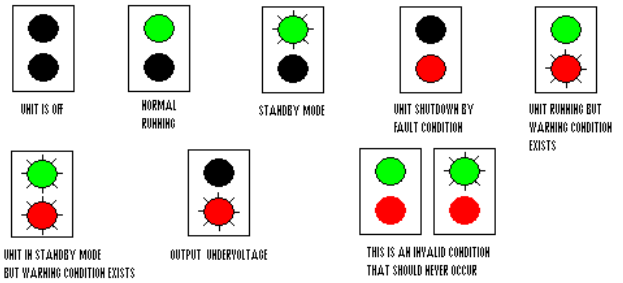

PUSH BUTTONS

The two push buttons located just above the LEDs can be used to adjust the output voltage when the output is enabled. These buttons are labelled V▲ and V▼. Short presses for a fraction of a second adjust the output voltage at the output voltage setting resolution. If the button is held down, the rate of change increases to around 1V/s after 10s. If both buttons are pressed together, the button adjust is cleared to zero. The PMBus can read the button adjust value and also clear the value. The PMBus can also be used to enable or disable the buttons.

PMBus SPECIFICATIONS

PHYSICAL ADDRESSING

The module responds to a single PMBus address. Multiple units can be used together on a single bus by configuring each module with a different physical address. Five of the address bits are brought out on the module connector and these may be either tied high (to 5VSB) or low (to SBReturn) to configure the address. The other two bits GA5 and GA4 are internally set to low and high respectively. The table below summarizes the addressing capability. This gives the module 32 possible addresses, in two banks of 16.

GA6	GA5	GA4	GA3	GA2	GA1	GA0	R/W
A2	0	1	A3	B3	C3	D3	x

BUS SPEED

Minimum10kHz
Maximum100kHz

DC SPECIFICATIONS

V_{il}, SMBus signal input low 0.8V max.
V_{ih}, SMBus signal input high 2.1V min. / 5.0V max.
V_{ol}, SMBus signal output low (@pullup) 0.4V min.
I_{pullup} Current sinking, V_{ol}=0.4V 4mA min.
C_i, capacitance of SCL or SDA pin 25pF max.

FAULT REPORTING

faults are reported using the SMBALERT signal. This allows the bus master to determine if a fault has occurred so that it can quickly determine which module has a fault.

Packet Error Checking (PEC)

The Bluestreak PMBus implementation supports packet error checking. The user may configure messages with an additional CRC check byte at the end. Any errors will cause an alert enabling the master to resend the message. Messages received from the module also have a PEC byte appended to the end. This byte may be read if required or only the message bytes may be read.

PMBus pin summary

The following table is a summary of all available PMBus pins with a short description of the function of each.

Pin	Name	Function
C6	SCL	SMBus Serial Clock
B6	SDA	SMBus Serial Data
D3	GA0	Address Configuration
C3	GA1	Address Configuration
B3	GA2	Address Configuration
A3	GA3	Address Configuration
A2	GA6	Address Configuration
A6	SMB ALERT	Alert Interrupt Signal
B2	CONTROL	Can be configured to turn the unit ON/OFF

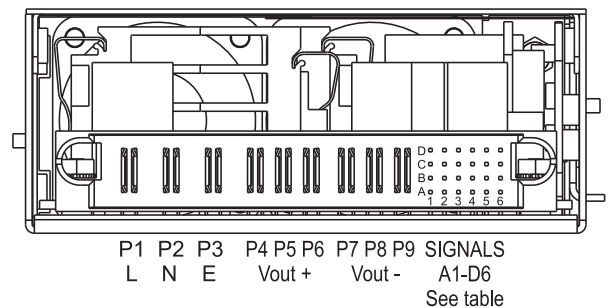

PMBus Command Summary

CODE	NAME	SHORT DESCRIPTION	CODE	NAME	SHORT DESCRIPTION
01h	OPERATION	Used for on/off and margining	78h	STATUS_BYTE	Reads the status byte
02h	ON_OFF_CONFIG	Used to configure the function of OPERATION	79h	STATUS_WORD	Reads the status word
03h	CLEAR_FAULTS	Clears status bytes and SMBALERT signal	7Ah	STATUS_VOUT	Reads the VOUT status register
12h	RESTORE_DEFAULT_ALL	Restores all user parameters from default store	7Bh	STATUS_IOUT	Reads the IOUT status register
15h	STORE_USER_ALL	Stores all user parameters in the user store	7Ch	STATUS_INPUT	Reads the INPUT status register
16h	RESTORE_USER_ALL	Restores all user parameters from user store	7Dh	STATUS_TEMPERATURE	Reads the TEMPERATURE status register
20h	VOUT_MODE	Reads the data format for VOUT related commands	7Eh	STATUS_CML	Reads the CML status register
21h	VOUT_COMMAND	Sets the output voltage	81h	STATUS_FANS_1_2	Reads the FAN status register
22h	VOUT_TRIM	Trims the output voltage	88h	READ_VIN	Reads the VIN voltage value
24h	VOUT_MAX	Sets the voltage above which an alert will be issued	8Ah	READ_VCAP	Reads the VCAP voltage value
25h	VOUT_MARGIN_HIGH	Sets the output voltage when high margin is set	8Bh	READ_VOUT	Reads the output voltage value
26h	VOUT_MARGIN_LOW	Sets the output voltage when low margin is set	8Ch	READ_IOUT	Reads the output current value
27h	VOUT_TRANSITION_RATE	Sets the rate of change of output voltage	8Dh	READ_TEMPERATURE_1	Reads the internal temperature value
42h	VOUT_OV_WARN_LIMIT	Sets the output over voltage warning limit	90h	READ_FAN_SPEED_1	Reads the speed of fan 1
43h	VOUT_UV_WARN_LIMIT	Sets the output under voltage warning limit	91h	READ_FAN_SPEED_2	Reads the speed of fan 2
44h	VOUT_UV_FAULT_LIMIT	Sets the output under voltage fault limit	98h	PMBUS_REVISION	Reads the revision of the PMBus implementation
45h	VOUT_UV_FAULT_RESPONSE	Sets the output under voltage fault response	99h	MFR_ID	Reads the manufacturer ID
46h	IOUT_OC_FAULT_LIMIT	Sets the output over current fault limit	9Ah	MFR_MODEL	Reads the power supply model number
47h	IOUT_OC_FAULT_RESPONSE	Sets the output over current fault response	9Bh	MFR_REVISION	Reads the power supply hardware revision
4Ah	IOUT_OC_WARN_LIMIT	Sets the output over current warning limit	9Ch	MFR_LOCATION	Reads the power supply manufacturer location
4Fh	OT_FAULT_LIMIT	Sets the over temperature fault limit	9Dh	MFR_DATE	Reads the power supply manufacture date
50h	OT_FAULT_RESPONSE	Sets the over temperature fault response	9Eh	MFR_SERIAL	Reads the power supply serial number
51h	OT_WARN_LIMIT	Sets the over temperature warning limit	D0h	OVP_SETTING	Sets the OVP voltage level
52h	UT_WARN_LIMIT	Sets the under temperature warning limit	D1h	READ_ISHARE	Reads the ISHARE current level
53h	UT_FAULT_LIMIT	Sets the under temperature fault limit	D2h	READ_VOUT_BUTTON_ADJ	Reads the voltage adjustment offset of the buttons
54h	UT_FAULT_RESPONSE	Sets the under temperature fault response	D3h	MINIMUM_FAN_SPEED	Sets the minimum fan speed
5Eh	POWER_GOOD_ON	Sets the output power good turn on voltage level	D4h	MISC_CONFIG	Enables front panel buttons, signal polarity,
5Fh	POWER_GOOD_OFF	Sets the output power good turn off voltage level	D5h	SOFTWARE_REVISION	Reads the software revision
60h	TON_DELAY	Sets the time before the output voltage comes up	D6h	MODEL	Reads the basic hardware model (12,24,48)
61h	TON_RISE	Sets the output voltage rise time.	D7h	PART_NUMBER	Reads the module part number (001-xxxx-xxxx)
64h	TOFF_DELAY	Sets the delay time before the output goes off			