

16

Instructions for Use

Safety Guideline for Turbomolecular Pumps	226
General Information	227
Storage	229
Preparation for installation	230
Installation	232
Pump Fixing	234
Use of TwisTorr 304 FS	235
Maintenance	237
Disposal	238

Original Instructions



Agilent Technologies

Safety Guideline for Turbomolecular Pumps

Turbomolecular pumps as described in the following operating manual contain a large amount of kinetic energy due to the high rotational speed in combination with the specific mass of their rotors.

In case of a malfunction of the system for example rotor/stator contact or even a rotor crash the rotational energy may be released.

WARNING!



To avoid damage to equipment and to prevent injuries to operating personnel the installation instructions as given in this manual should be strictly followed!

General Information

This equipment is destined for use by professionals. The user should read this instruction manual and any other additional information supplied by Agilent before operating the equipment. Agilent will not be held responsible for any events occurring due to non-compliance, even partial, with these instructions, improper use by untrained persons, non-authorized interference with the equipment or any action contrary to that provided for by specific national standards.

The TV 304 TwisTorr is a turbo-molecular pump for high and ultra-high vacuum applications which is able pump any type of non-corrosive gas or gas compound. It is not suitable for pumping liquids or solid particles.

The pumping action is obtained through a high speed turbine (max. 60000 rpm) driven by a high-performance 3-phase electric motor. The T TV 304 TwisTorr is free of contaminating agents and, therefore, is suitable for applications requiring a "clean" vacuum.

The following paragraphs contain all the information necessary to guarantee the safety of the operator when using the equipment. Detailed information is supplied in the appendix "Technical Information".

This manual uses the following standard protocol:

WARNING!



The warning messages are for attracting the attention of the operator to a particular procedure or practice which, if not followed correctly, could lead to serious injury.

CAUTION!

The caution messages are displayed before procedures which, if not followed, could cause damage to the equipment.

NOTE

The notes contain important information taken from the text.

Storage

In order to guarantee the maximum level of performance and reliability of Agilent Turbomolecular pumps, the following guidelines must be followed:

- when shipping, moving and storing pumps, the following environmental specifications should not be exceeded:
 - temperature range: -40 °C to 70 °C
 - relative humidity range: 0 to 90 % (non condensing)
- the turbomolecular pumps must be always soft-started when received and operated for the first time by the customer
- the shelf life of a turbomolecular pump is 12 months from the shipping date.

CAUTION!

If for any reason the shelf life time is exceeded, the pump has to be returned to the factory. Please contact the local Agilent Vacuum Sales and Service representative for informations.

Preparation for installation

The TV 304 TwisTorr pump is supplied in a special protective packing. If this shows signs of damage which may have occurred during transport, contact your local sales office.

When unpacking the pump, be sure not to drop it and avoid any kind of sudden impact or shock vibration to the TV 304 TwisTorr pump.

Do not dispose of the packing materials in an unauthorized manner. The material is 100% recyclable and complies with EEC Directive 94/62 and subsequent amendments.

CAUTION!

In order to prevent outgassing problems, do not use bare hands to handle components which will be exposed to vacuum. Always use gloves or other appropriate protection.

NOTE

Normal exposure to the environment cannot damage the TwisTorr 304 FS. Nevertheless, it is advisable to keep it closed until it is installed in the system, thus preventing any form of pollution by dust.

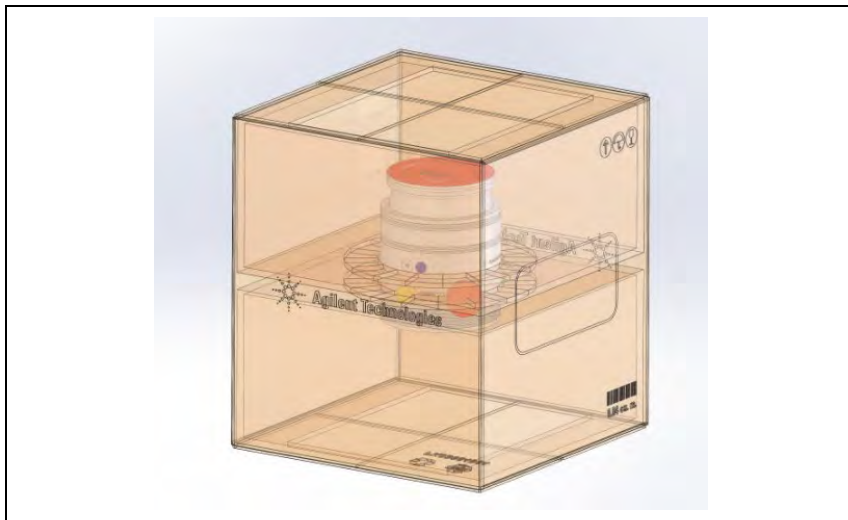

Figure 1 X3500-64000, X3500-64002, X3500-64004, X3500-64006,
X3500-64010

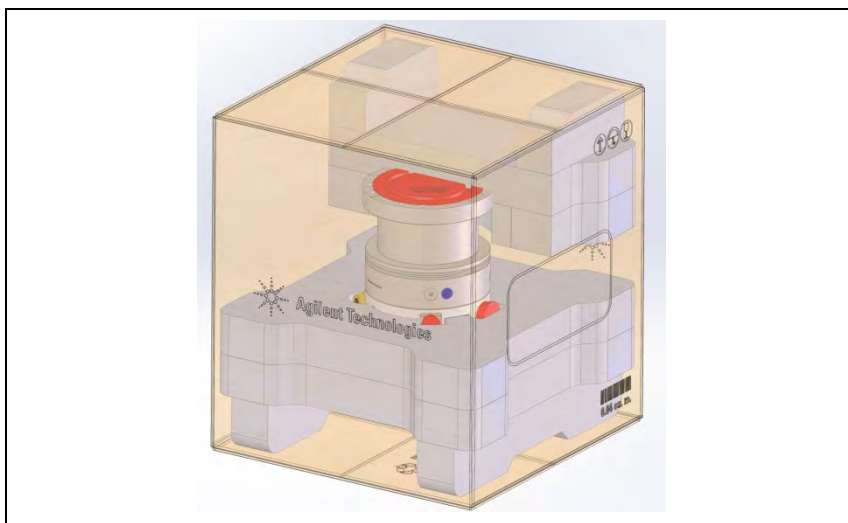

Figure 2 X3500-64001, X3500-64003, X3500-64005, X3500-64007

Installation

CAUTION!

Do not remove the adhesive and protective cap before connecting the turbopump to the system.



Figure 3

Install this device indoors only, and in any case do not use the pump in an environment exposed to atmospheric agents (rain, ice, snow), dust, aggressive gases, or in explosive environments or those with a high fire risk.

During operation, the following environmental conditions must be respected:

- maximum pressure: 2 bar above atmospheric pressure
- temperature: from +5 °C to +35 °C
- relative humidity: 0 – 90 % (non-condensing)

In the presence of magnetic fields the pump must be protected using a ferromagnetic shield. See the appendix "Technical Information" for detailed information.

The TwisTorr 304 FS pumps must be used in conjunction with one of the suitable Agilent controller and they must be connected to a primary pump (see "Technical Information").

Tab. 1

CONTROLLER	PART NUMBER	PRODUCT NAME
Controller AG Rack base	X3506-64001	TwisTorr 304 FS AG Rack
Controller AG Rack with RS232/485	X3506-64002	TwisTorr 304 FS AG Rack RS232/485
Controller AG Rack with RS232/485 & Profibus	X3506-64003	TwisTorr 304 FS AG Rack Profibus
Controller V304 onboard 24Vdc	X3507-64002	TwisTorr 304 FS onboard 24V
Controller V304 onboard 100-240Vac	X3507-64003	TwisTorr 304 FS onboard 110/220V

CAUTION!

The TwisTorr 304 FS belongs to the second installation (or overvoltage) category as per directive EN 61010 1. Connect the device to a mains line that satisfy the above category.

For installation of optional accessories, see "Technical Information".

Pump Fixing

WARNING!

Failure to comply with these installation instructions could result in the pump detaching from the system in the event of a rotor failure, which could cause property damage or serious injury or death.

The TwisTorr 304 FS can be installed in any position. Fix the TwisTorr 304 FS in a stable position, mounting the inlet flange of the turbopump to the system counter-flange, with a connection capable of withstanding a torque of 1000 Nm around its axis.

The ISO-K flange can be fixed using high strength steel clamps (like Agilent model IC63250DCMZ).

The following table shows, for each flange, the necessary number of IC63250DCMZ clamps and the relevant fixing torque.

Tab. 2

FLANGE	FIXING DEVICE	N.	FIXING TORQUE
ISO 100 K	M10 clamps	4	22 Nm
ISO 160 K	M10 clamps	4	22 Nm

The turbopump with ConFlat inlet flange must be fixed to the vacuum chamber by means of the appropriate Agilent hardware. See the appendix "Technical Information" for a detailed description.

NOTE

The TwisTorr 304 FS cannot be fixed by means of its base.

Use of TwisTorr 304 FS

All the instructions to correctly use the turbopump are contained in the controller manual. Read carefully this manual before use the pump. To obtain better limit pressures it is possible to heat the pump.

While heating the vacuum chamber, the temperature of the inlet flange must not exceed 120 °C for a ConFlat flange and 80 °C for a ISO flange. While heating always use the water cooling.

WARNING!



Never use the turbopump when the inlet flange is not connected to the vacuum chamber. Do not touch the turbopump or any of its accessories during the heating process. The high temperatures may cause burns.

CAUTION!

Avoid impacts, oscillations or harsh movements of the pump when in operation. The bearings may become damaged. Use air or inert gas free from dust or particles for venting the pump. The pressure at the vent port must be less than 2 bar (above atmospheric pressure). For pumping gases containing particulate or aggressive pollutants for the bearings, these pumps are fitted with a special port (integrated purge/vent device) to allow a steady flow of inert gas (He, N₂, Ar) for pump bearing protection (see the annex "Technical Information").

ATTENZIONE!

Never use the pump with corrosive gases or vapor to avoid damage to the internal materials of the pump.

WARNING!



When employing the pump for pumping toxic, flammable, or radioactive gases, please follow the required procedures for each gas disposal. Do not use the pump in presence of explosive gases. The pump is designed to pump high throughput of N₂, Ar and lighter gas. Should you need to pump gases heavier than Ar, please contact Agilent technical support for information.

Maintenance

The TwisTorr 304 FS does not require any maintenance. Any work must be carried out by authorized personnel.

WARNING!



Before carrying out any work on the system, disconnect it from the mains, vent the pump by opening the appropriate valve, wait until the rotor has stopped turning and wait until the surface temperature of the pump falls below 50 °C.

In the case of breakdown, contact your local Agilent service center or "Agilent advanced exchange service" who can supply a reconditioned system to replace that broken down.

NOTE

Before returning the pump to the constructor for repairs, or advanced exchange service, the "Request for Return" sheet attached to this instruction manual must be filled-in and sent to the local sales office. A copy of the sheet must be inserted in the system package before shipping.

If a system is to be scrapped, it must be disposed of in accordance with the specific national standards.

Disposal

Meaning of the "WEEE" logo found in labels The following symbol is applied in accordance with the EC WEEE (Waste Electrical and Electronic Equipment) Directive. This symbol (**valid only in countries of the European Community**) indicates that the product it applies to must NOT be disposed of together with ordinary domestic or industrial waste but must be sent to a differentiated waste collection system. The end user is therefore invited to contact the supplier of the device, whether the Parent Company or a retailer, to initiate the collection and disposal process after checking the contractual terms and conditions of sale.



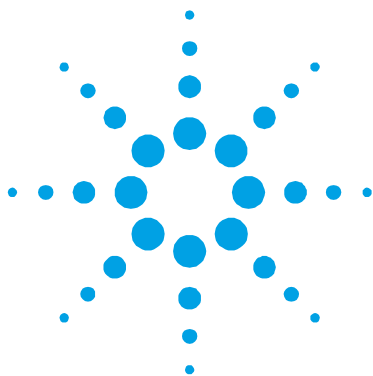

17

Technical Information

Description of the TwisTorr 304 FS	241
Pump Description	246
Technical Specification	248
TwisTorr 304 FS Outline	251
Interconnections	270
Earth (Ground) Connection	270
Connection C – Electrical	271
Soft Start	272
Inlet screen installation	273
Air Cooling Kit Installation	276
Water Cooling Kit Connection	278
Vent Accessories	281
TwisTorr 304 FS on board controller compatible Vent Valve mod. 969-9834	281
TwisTorr 304 AG Rack Controller Compatible Vent Valve mod. 969-9844	283
Vibration Isolator Installation	285
Purge Valve Installation	286
TwisTorr 304 FS On-board Controller Installation	288
Bottom Mounting	288
Side Mounting	289

Original Instructions



Agilent Technologies

Connection of the High Vacuum Flange	290
Installation of ISO-K Flange	291
Installation of ConFlat Flange	292
Connection of the Fore-Vacuum Pump	294
Pump Used with Corrosive Gases	295
Pump Used in Presence of Magnetic Fields	297
Accessories and Spare Parts	298

Description of the TwisTorr 304 FS

The TwisTorr 304 FS pump is available in various models that differ in the high vacuum flange.

The TwisTorr 304 FS pump models are:

Model X3500-64000 with ISO 100 high vacuum flange with water cooling;

Model X3500-64001 with ConFlat 6" external diameter high vacuum flange with water cooling;

Model X3500-64002 with ISO160 high vacuum flange with water cooling;

Model X3500-64003 with ConFlat 8" external diameter high vacuum flange with water cooling;

Model X3500-64004 with ISO 100 high vacuum flange without water cooling;

Model X3500-64005 with ConFlat 6" external diameter high vacuum flange without water cooling;

Model X3500-64006 with ISO160 high vacuum flange without water cooling;

Model X3500-64007 with ConFlat 8" high vacuum flange without water cooling;

Model X3500-64010 (Split Flow) with ISO 100 high vacuum flange and KF40 side port flange with water cooling;

The following figures shows the 9 models.

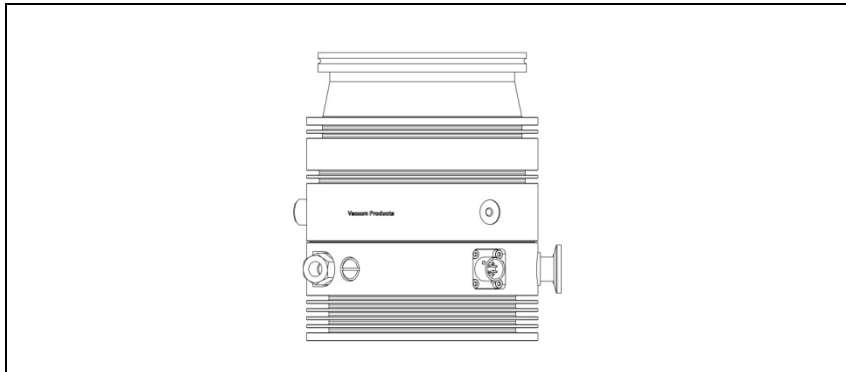

Figure 4 Model X3500-64000

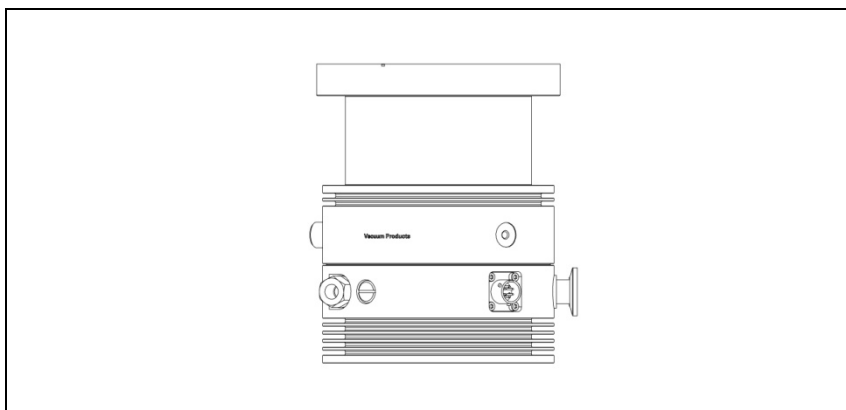

Figure 5 Model X3500-64001

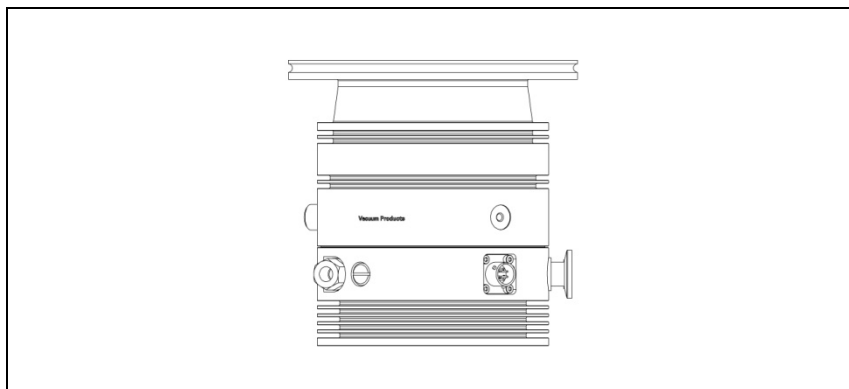

Figure 6 Model X3500-64002

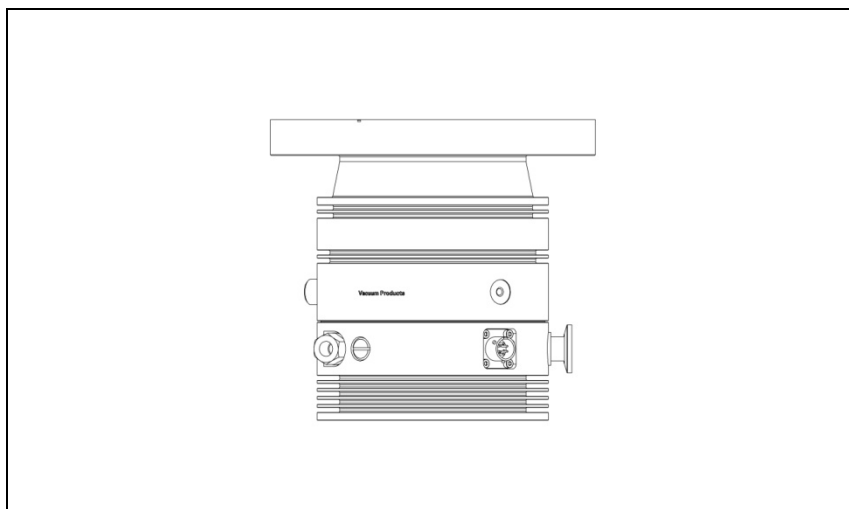

Figure 7 Model X3500-64003

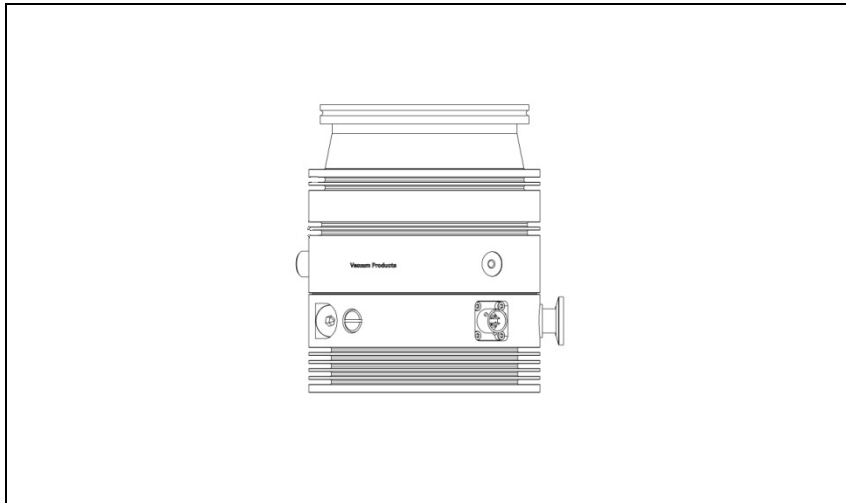

Figure 8 Model X3500-64004

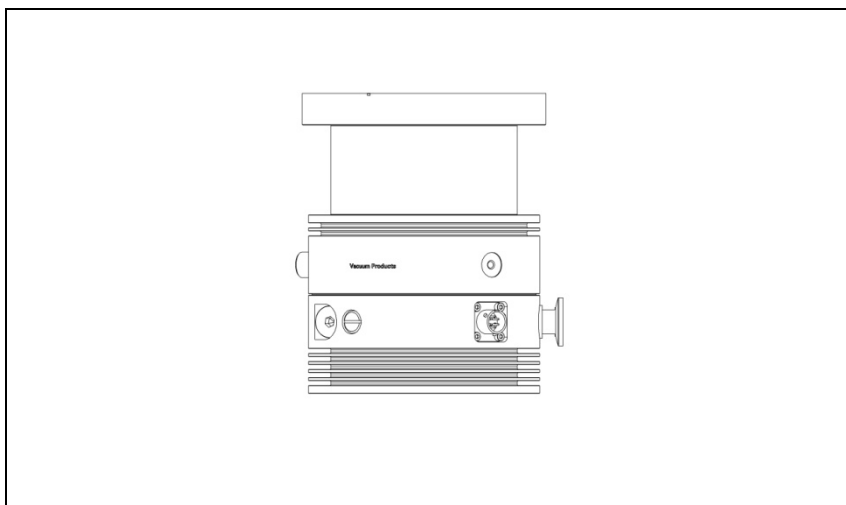

Figure 9 Model X3500-64005

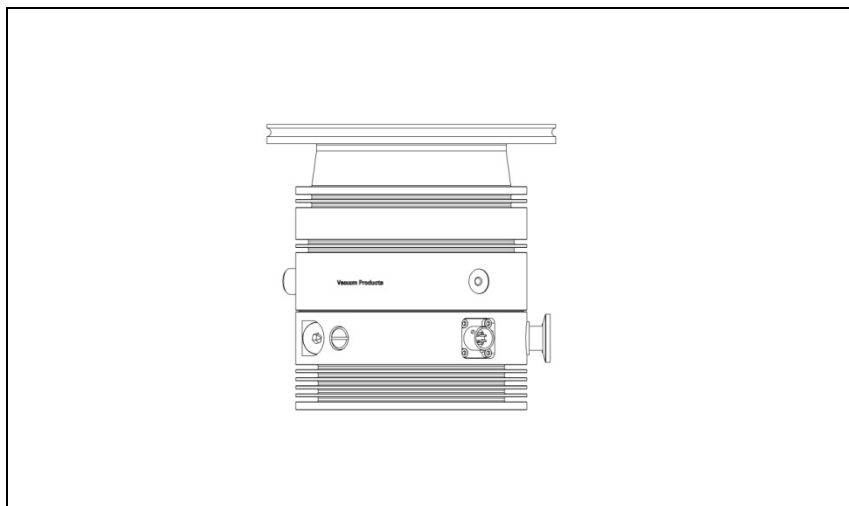

Figure 10 Model X3500-64006

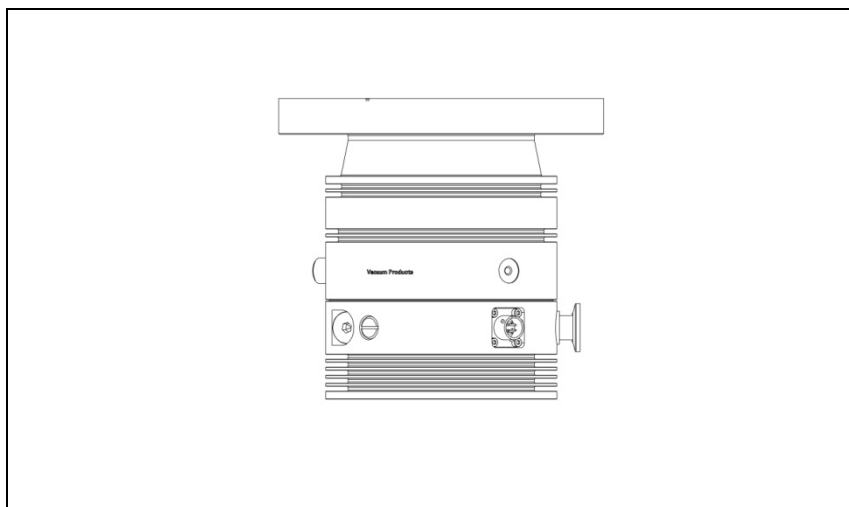

Figure 11 Model X3500-64007

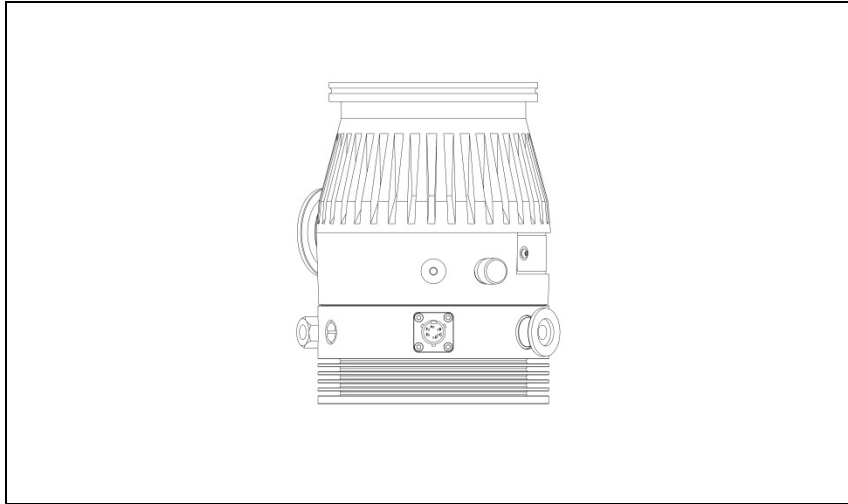

Figure 12 Model X3500-64010

Pump Description

The TwisTorr 304 pump consists of a high frequency motor driving a turbine fitted with 8 bladed stages and 3 TwisTorr drag stages. The turbine rotates in an anticlockwise direction when viewed from the high vacuum flange end.

The turbine is made of high-strength aluminium alloy, machined from a single block. The TwisTorr stages are in the form of three disks.

The turbine rotor is supported by permanently lubricated high precision ceramic ball bearings in-stalled on the forevacuum side of the pump.

The static blades of the stator are made of stainless steel. These are supported and accurately positioned by spacer rings.

The TwisTorr stators are in the form of selfpositioning machined disks. On each disk there are parallel spiral pumping channels designed to pump in centrifugal direction on one side and in centripetal direction on the other side. These are made of aluminium alloy.

During normal operation, the motor is fed with a voltage of 54 Vac three-phase at 1010 Hz. To reduce losses during start-up to a minimum, the frequency increases according to a ramp with a higher initial voltage/frequency ratio.

WARNING!



The pump must always be cooled before starting using it. Running the pump without cooling it could damage inside components.

The pump can be water cooled or air cooled: in the first case the customer can use the dedicated channels on the pump body, in the second case an external optional fan is available (model X3500-68011). A thermistor sensor is mounted near the upper bearing to prevent the pump from overheating.

If the thermistor reading exceeds 60 °C the pump fails and stops with Error Code = 2. If the thermistor reading is below 0 °C, the pump fails and stops with Error Code = 1 (see Controller Manual),

The pump can operate in any position and can be supported on the high vacuum flange. The connection of the forevacuum on the side of the pump is a KF 16 NW flange (KF25 – optional).

Technical Specification

- Max gas throughput:
 - water cooling (water temperature=25°C; backing pump 5 m³/h)
 - air cooling (ambient temperature 25°C; backing pump 5 m³/h)

Tab. 3 Technical Specification

Pumping speed	ISO 100 / CF 6"	ISO 160 / CF 8"
N ₂	250 l/s	250 l/s
He	255 l/s	255 l/s
H ₂	220 l/s	220 l/s
Ar	250 l/s	250 l/s
Max gas throughput at full rotational speed (with recommended forepump)	Air cooling	Water cooling
N ₂	170 sccm	170 sccm
Ar	110 sccm	110 sccm
Compression ratio		
N ₂	>1 × 10 ¹¹	
He	>1 × 10 ⁸	
H ₂	1.5 × 10 ⁶	
Ar	> 1 × 10 ¹¹	
Base pressure with recommended forepump	< 1 × 10 ⁻¹⁰ mbar (< 1 × 10 ⁻¹⁰ Torr) (According to standard DIN 28 428, the base pressure is that measured in a leak-free test dome, 48 hours after the completion of test dome bake-out, with a Turbopump fitted with a ConFlat flange and using the recommended pre-vacuum pump)	
Inlet flange	CFF 8" O.D.	ISO 160
	CFF 6" O.D.	ISO 100
Foreline flange	KF16 NW (KF25 – optional)	
Rotational speed	60000 rpm (1010 Hz driving frequency)	
Start-up time	< 3 minutes	
Recommended forepump	mechanical: Agilent DS 102 mechanical: Agilent DS 302 dry pump: Agilent SH 110	
Operating position	Any	

Operating ambient temperature	+5 °C to +35 °C
Relative humidity of air	0 – 90 % (not condensing)
Bakeout temperature	80 °C at inlet flange max.
Lubricant	Permanent lubrication
Cooling requirements	Natural convection (only with no gas load) Forced air (5- 35 °C ambient temperature) Water (mandatory if ambient temperature > 35 °C)
Coolant water	Minimum flow: 50 l/h (0.89 GPM) Temperature: +15 °C to +30 °C Pressure: 3 to 5 bar (45 to 75 psi)
Noise Pressure level	< 50 dB(A) at 1 meter
Pwr supply (mains):	
Max input pwr:	300 VA
Stand-by pwr:	10 W
Max oper. power:	150 W with water or air cooling
Installation category	II
Pollution degree	2
Storage temperature	-40° C to +70° C
Max altitude	3000 m
Weight kg (lbs):	
Pump ISO 100	5.5 kg (12.3)
Pump CFF 6''	7.5 kg (16.5)
Pump ISO 160	5.7 kg (12.6)
Pump CFF 8''	9.7 kg (20.9)

Tab. 4 Split Flow (X3500-64010) Technical Specification

Pumping speed *	Main Flange (ISO 100)	Side Port (KF40)
N ₂	220 l/s	5 l/s
He	215 l/s	6.5 l/s
H ₂	215 l/s	7 l/s
Ar	210 l/s	4 l/s
Compression ratio	Total	Foreline/Side Port
N ₂	$>1 \times 10^{11}$	$>1 \times 10^6$
He	1×10^7	2.5×10^4
H ₂	1.5×10^5	1×10^3
Ar	$>1 \times 10^{11}$	$>1 \times 10^6$
Max gas throughput at full rotational speed (with recommended forepump)	Air cooling/Water cooling	
N ₂	170 sccm	
Ar	110 sccm	

* Pumping speed measured with fluximeter.

TwisTorr 304 FS Outline

The following figures show the TwisTorr 304 FS (dimensions are in mm [inches]).

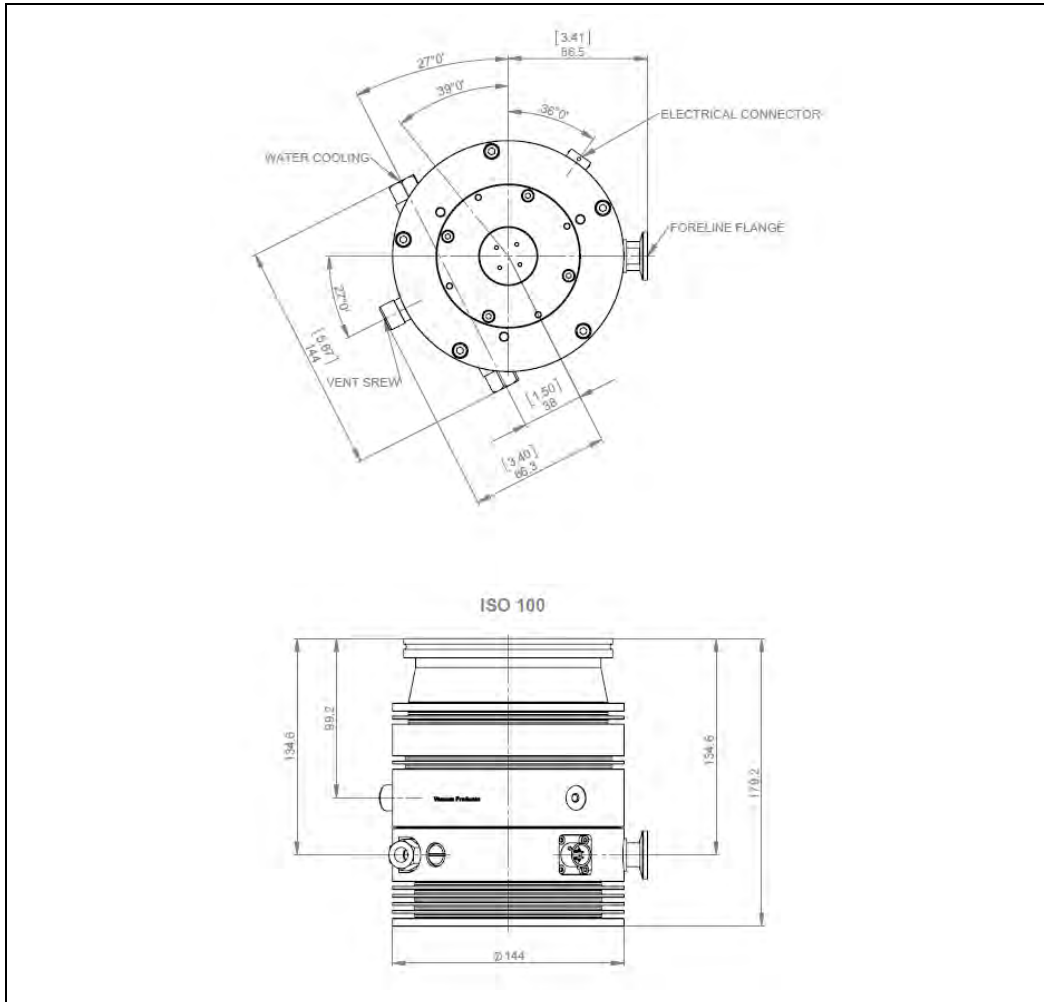

Figure 13 TwisTorr 304 FS ISO 100 (X3500-64000)

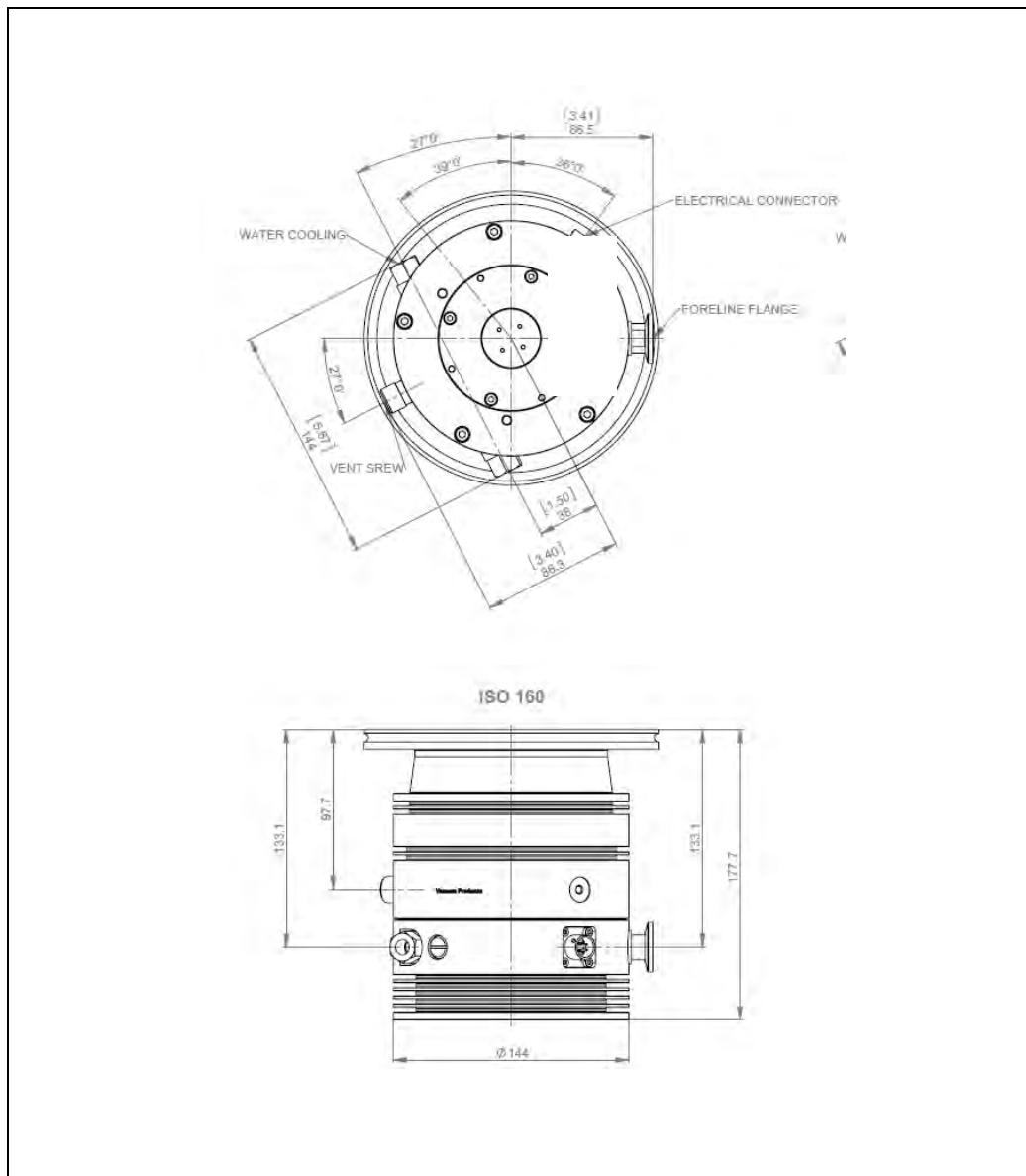

Figure 14 TwisTorr 304 FS (X3500-64002)

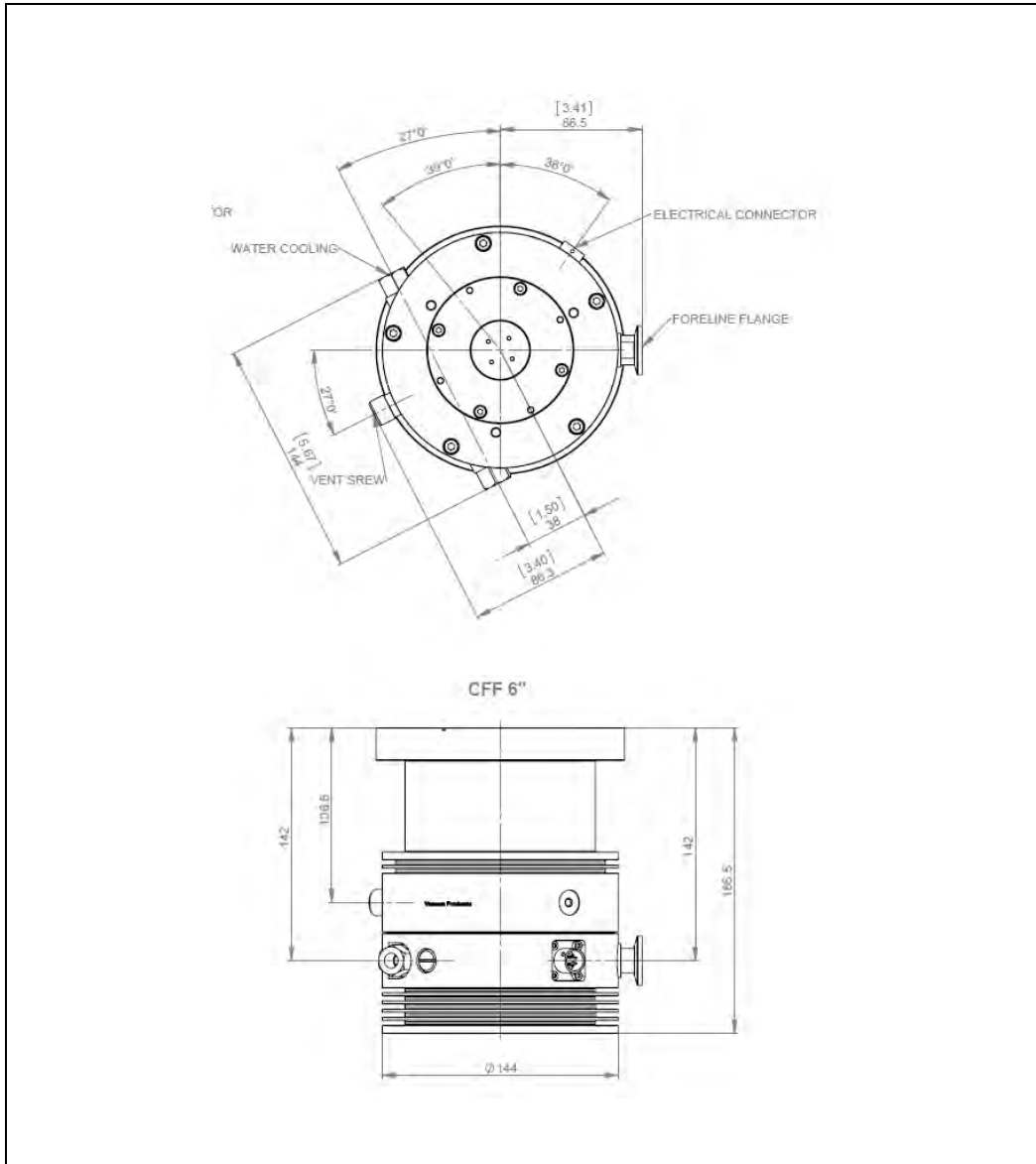

Figure 15 TwisTorr 304 FS (X3500-64001)

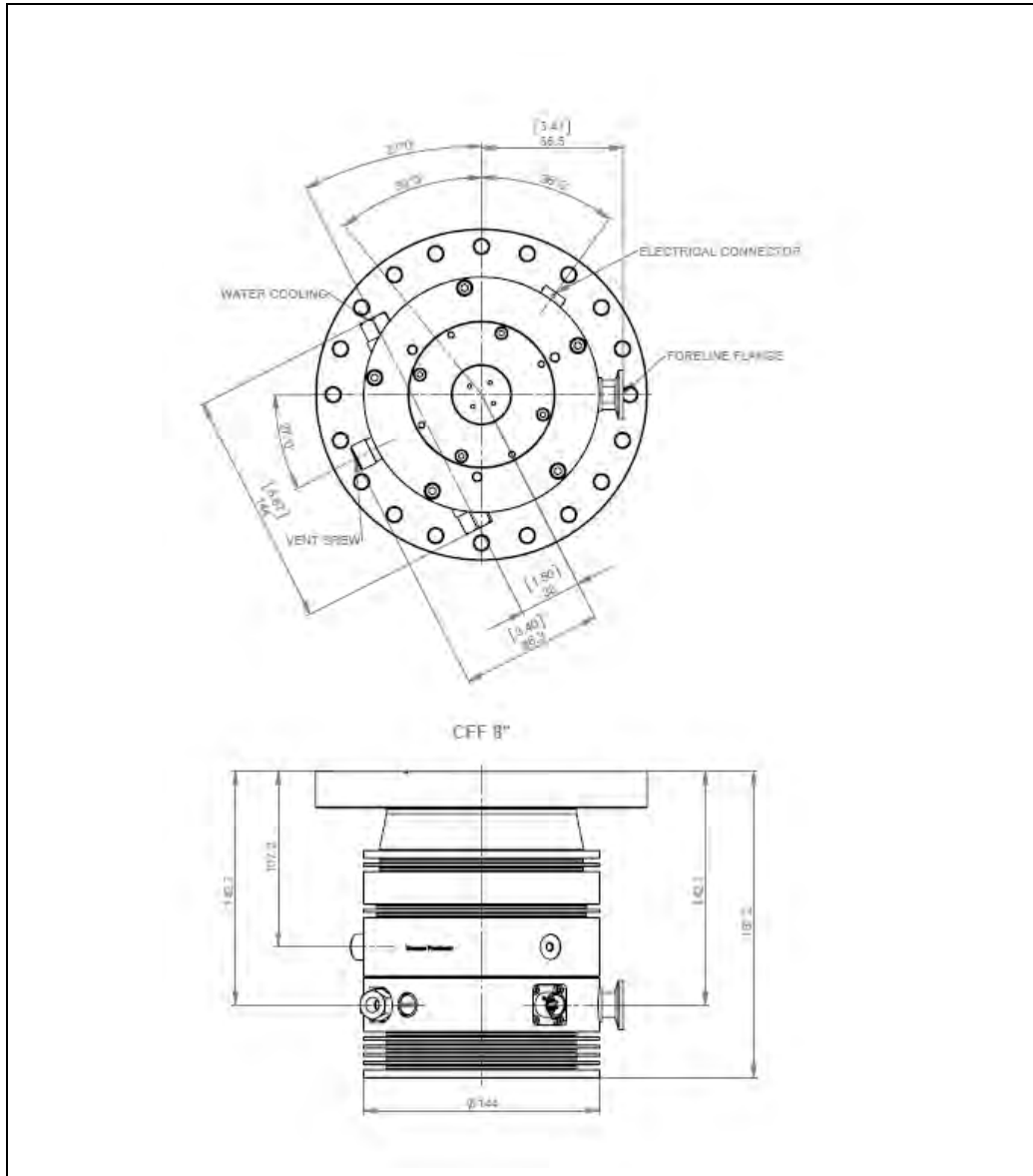

Figure 16 TwisTorr 304 FS (X3500-64003)

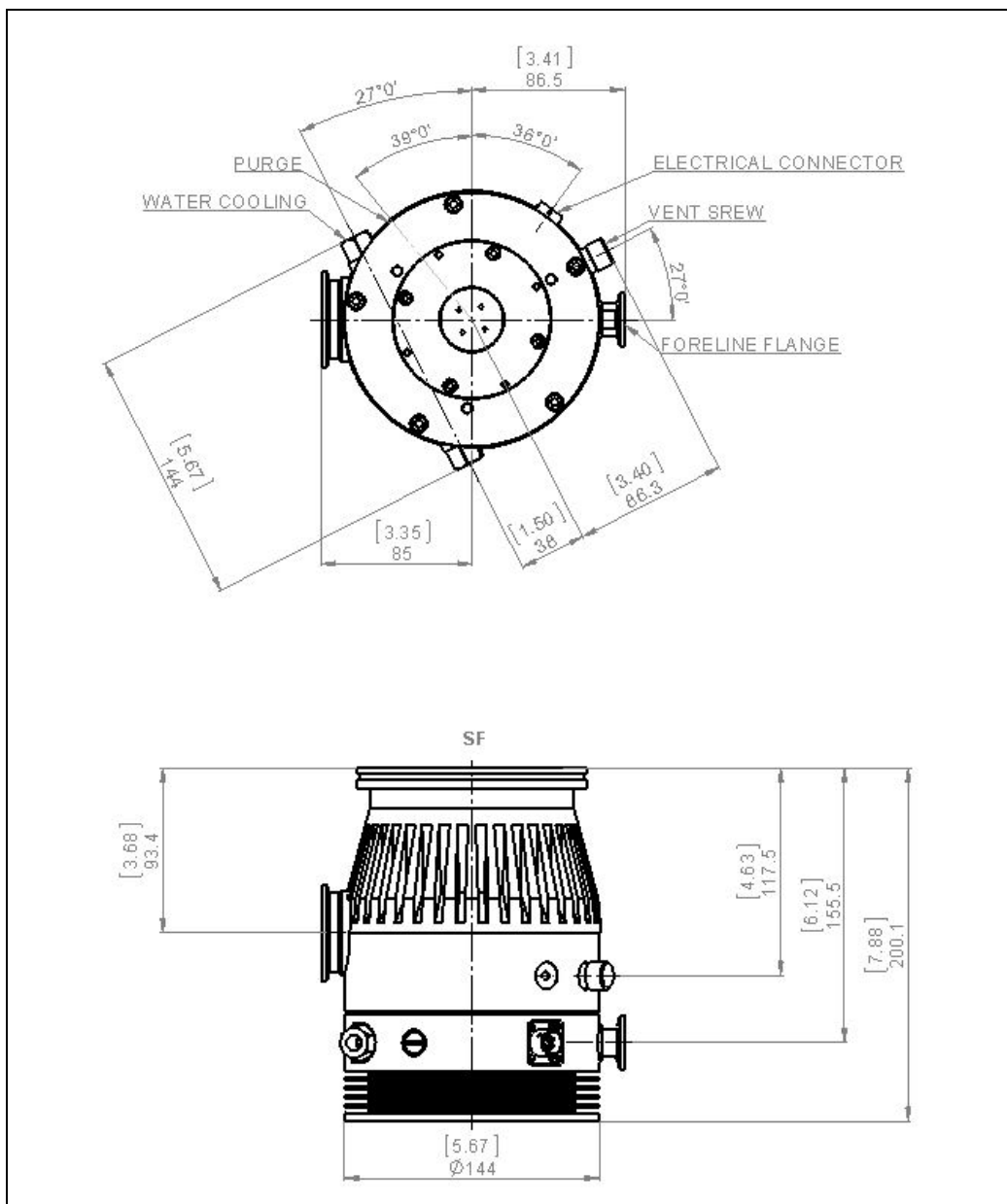

Figure 17 TwisTorr 304 FS (X3500-64010)

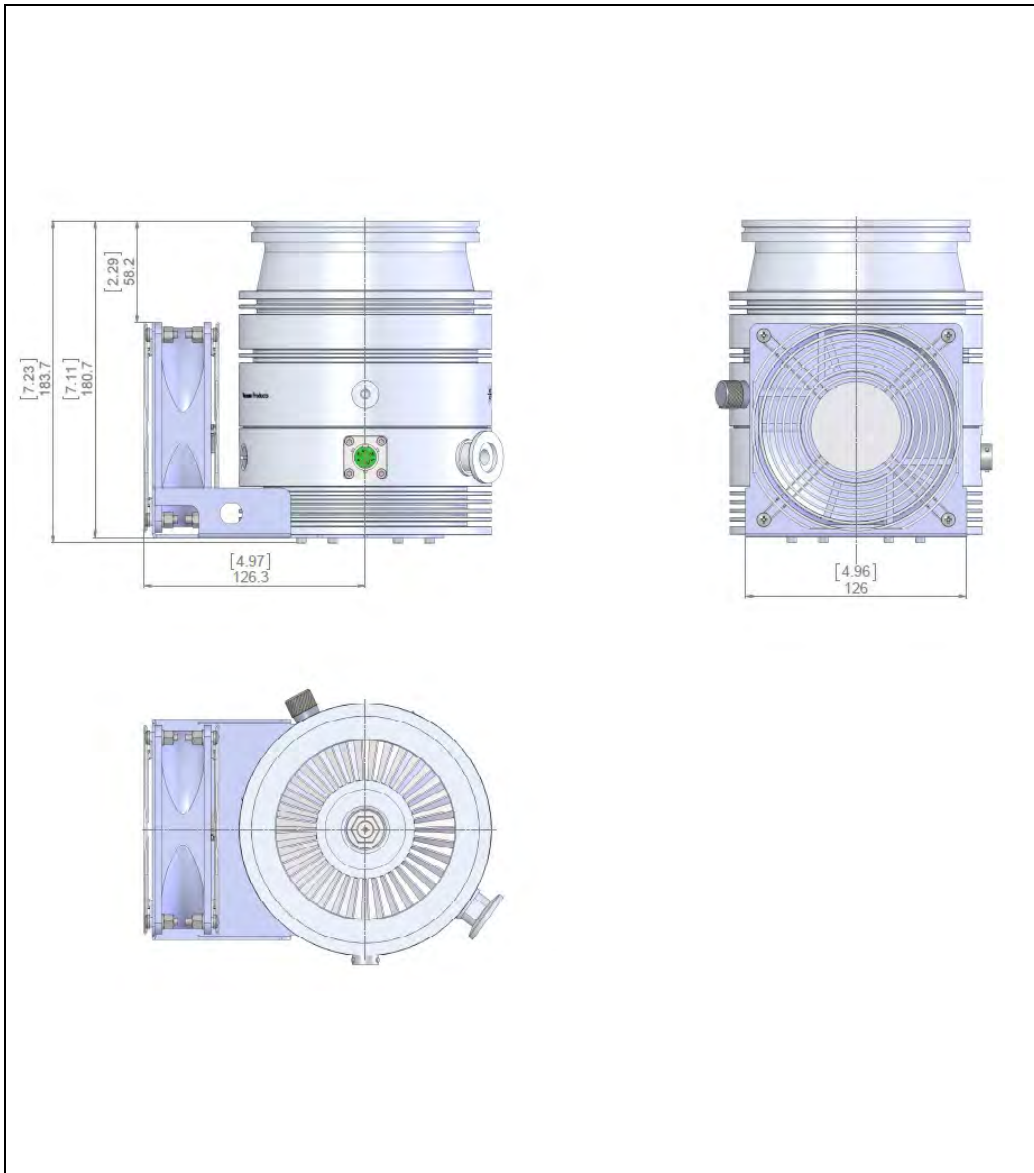

Figure 18 TwisTorr 304 FS + air cooling kit (X3500-64004 + X3500-68011)

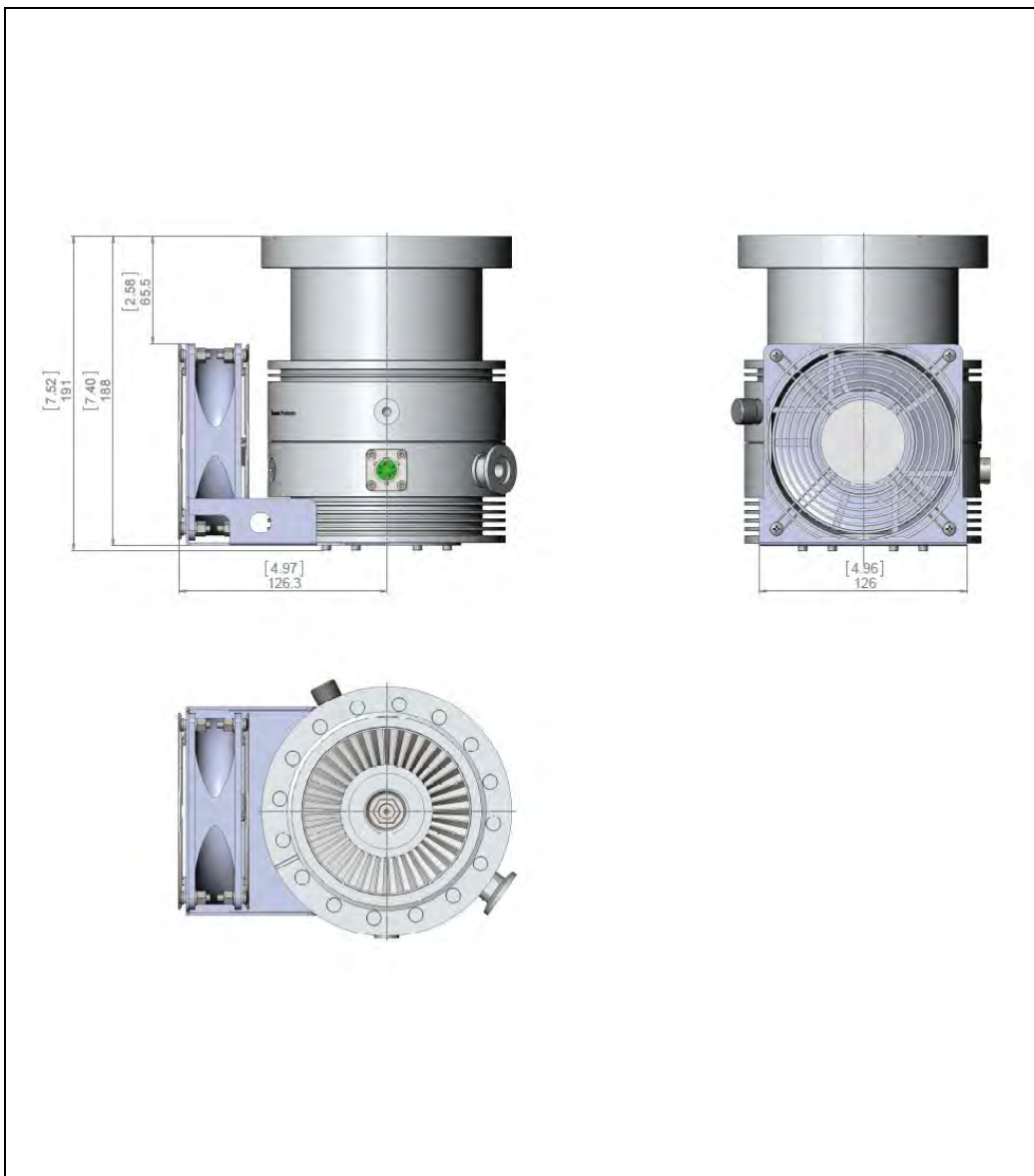

Figure 19 TwisTorr 304 FS + air cooling kit (X3500-64005 + X3500-68011)

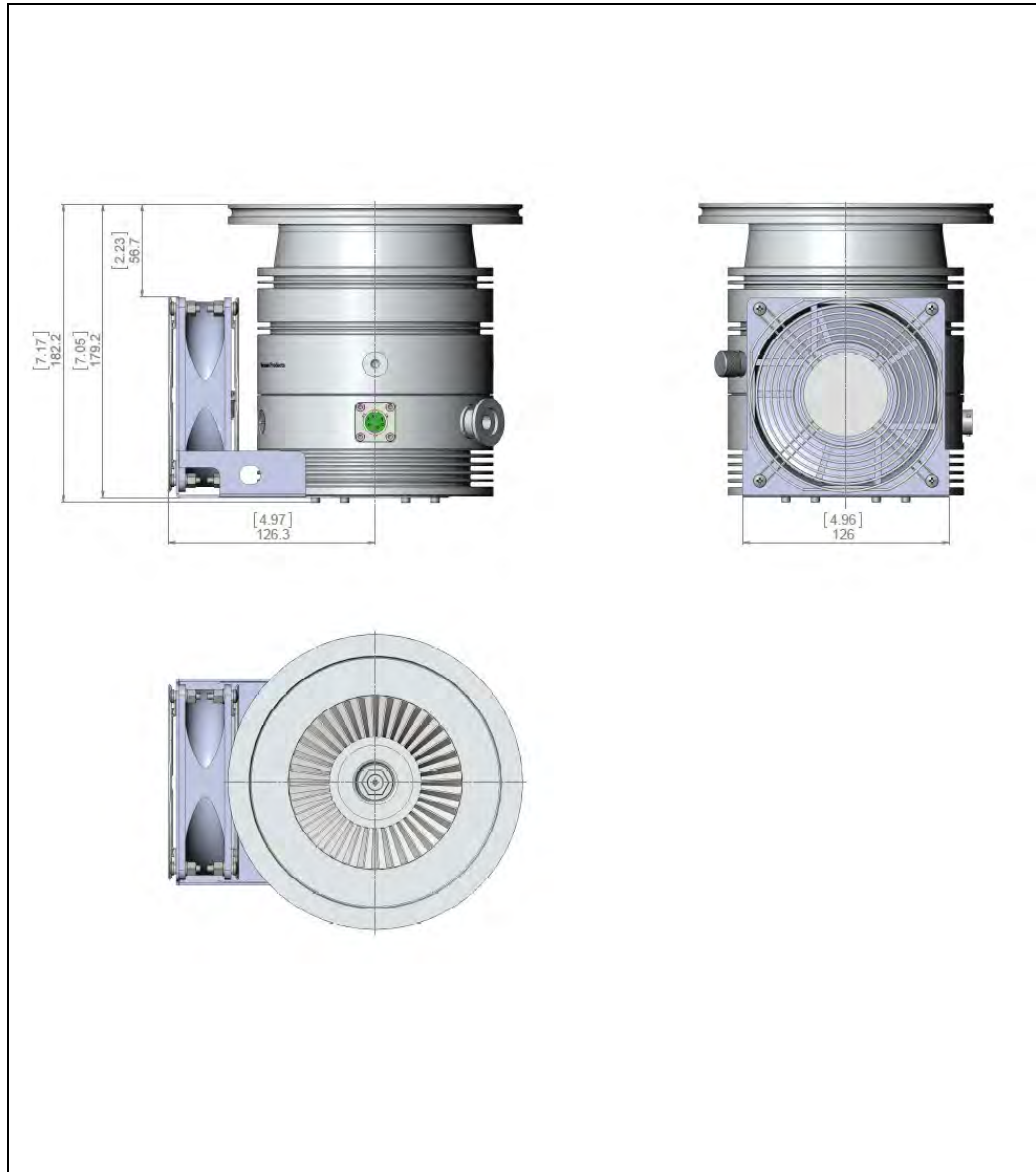

Figure 20 TwisTorr 304 FS + air cooling kit (X3500-64006 + X3500-68011)

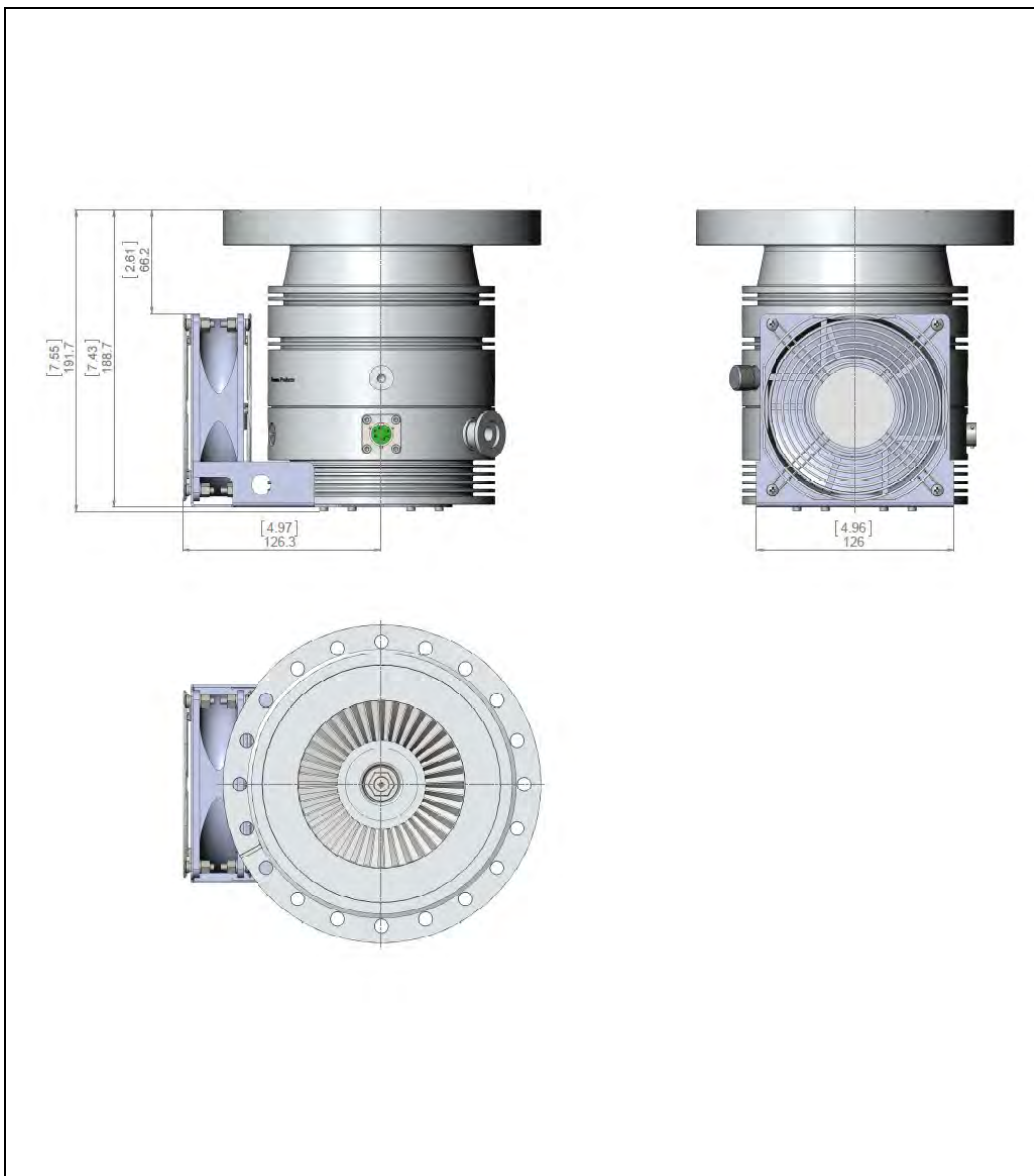

Figure 21 TwisTorr 304 FS + air cooling kit (X3500-64007 + X3500-68011)

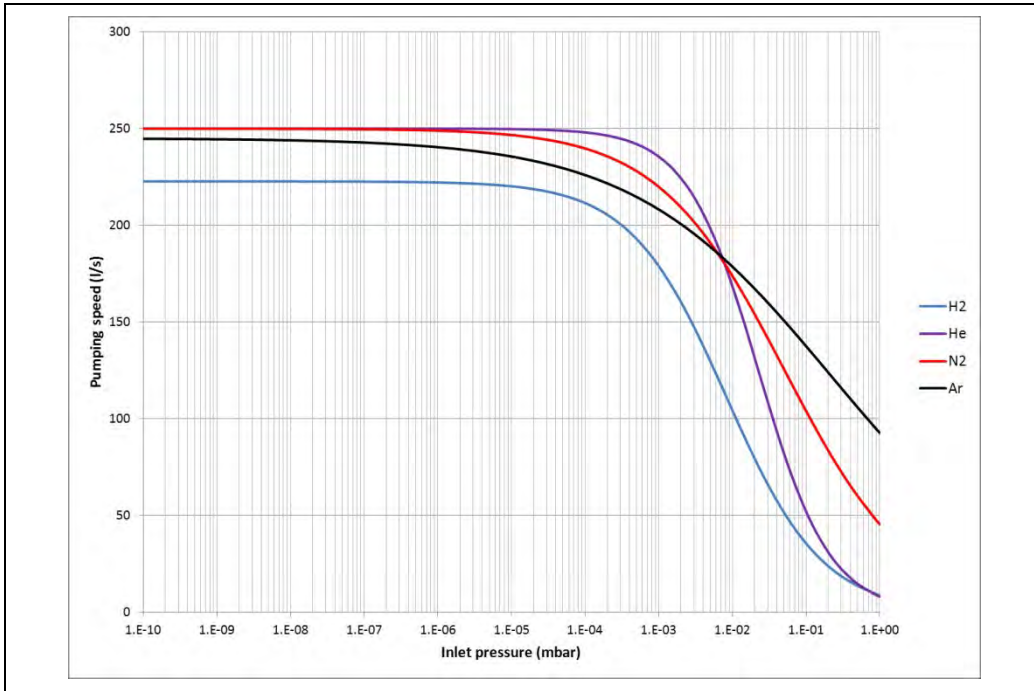

Figure 22 Graph of Pumping Speed vs. Inlet Pressure for TwisTorr 304 FS pump

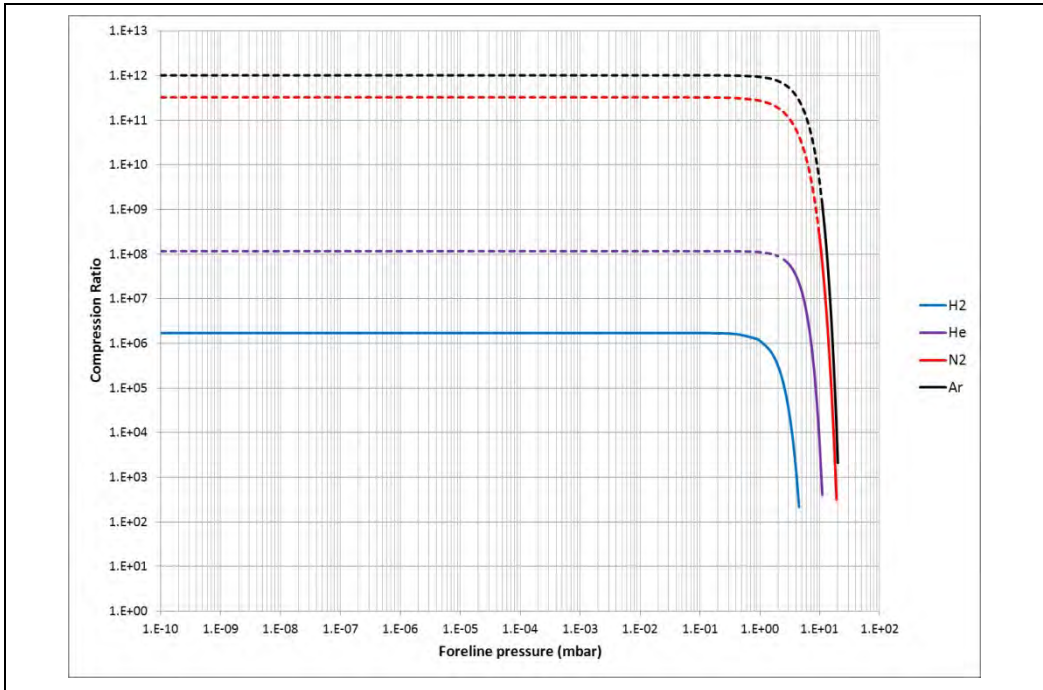

Figure 23 Graph of Compression ratio vs. Foreline Pressure for TwisTorr 304 FS pump

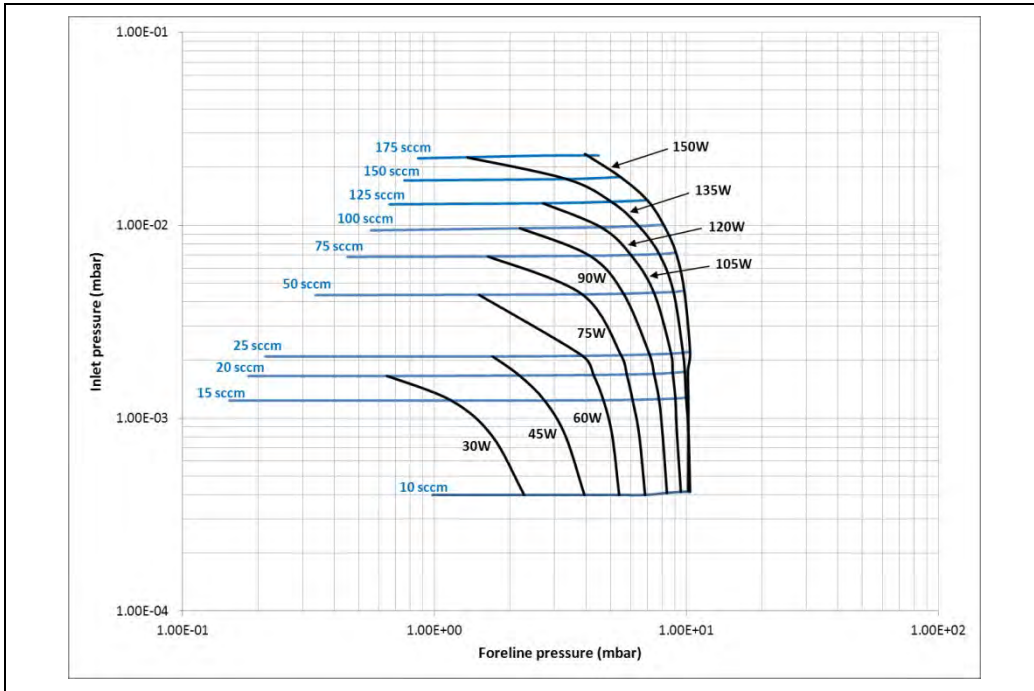

Figure 24 Graph of Iso Flow – Iso Power TwisTorr 304 FS pump: Nitrogen

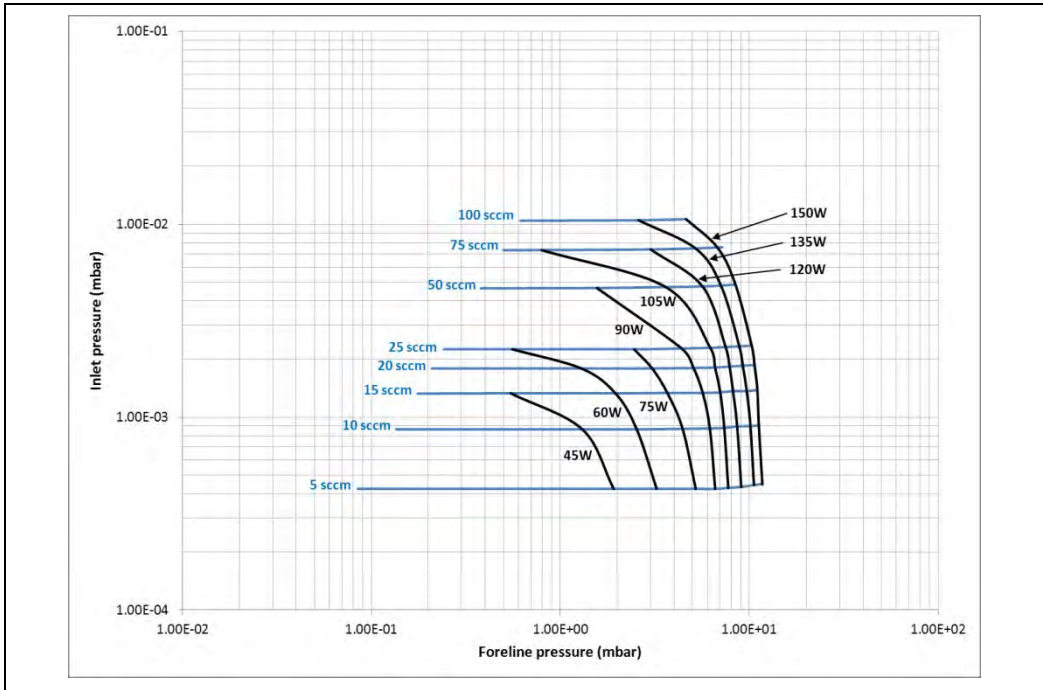

Figure 25 Graph of Iso Flow – Iso Power TwisTorr 304 FS pump: Argon

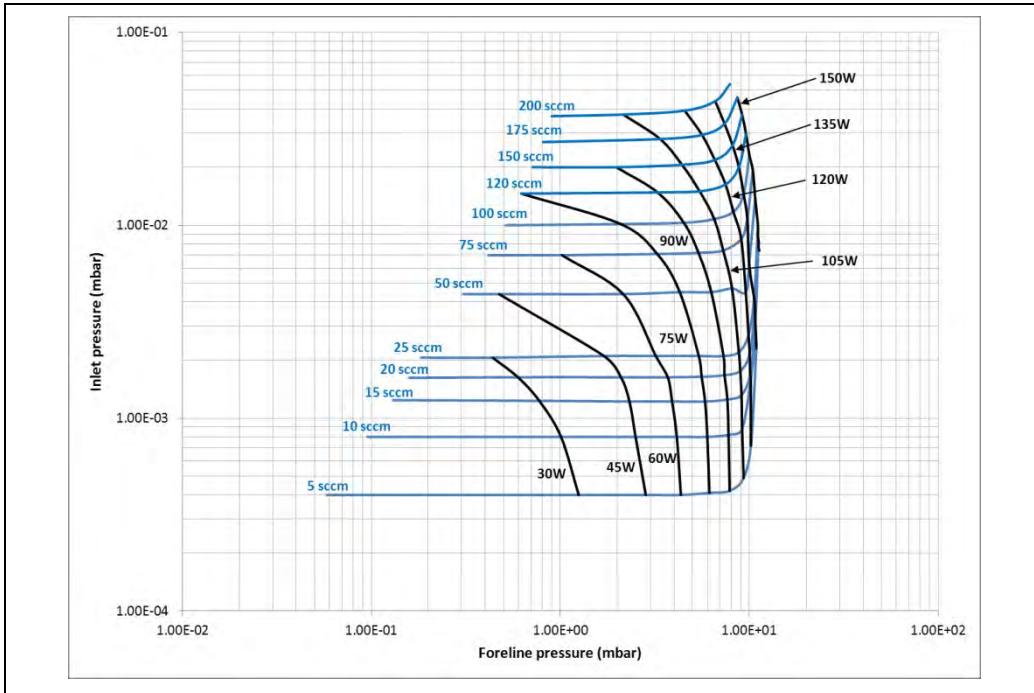

Figure 26 Graph of Iso Flow – Iso Power TwisTorr 304 FS pump: Helium

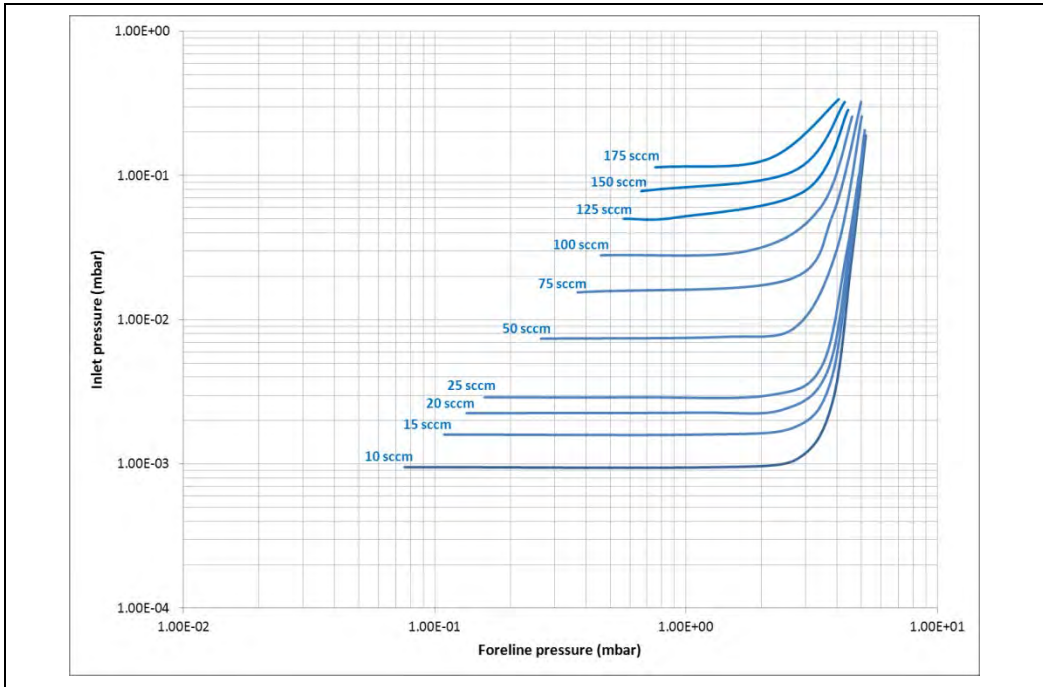

Figure 27 Graph of Iso Flow TwisTorr 304 FS pump: Hydrogen

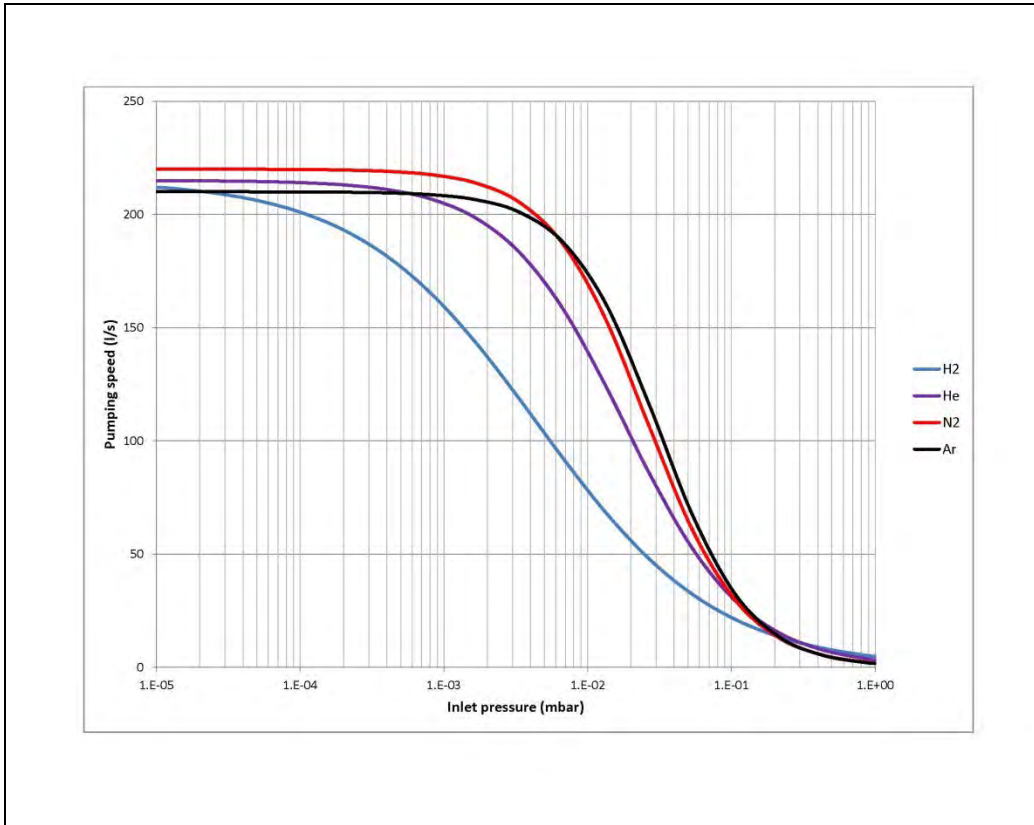

Figure 28 Split Flow (X3500-64010): Graph of Pumping Speed (Main Flange ISO100)

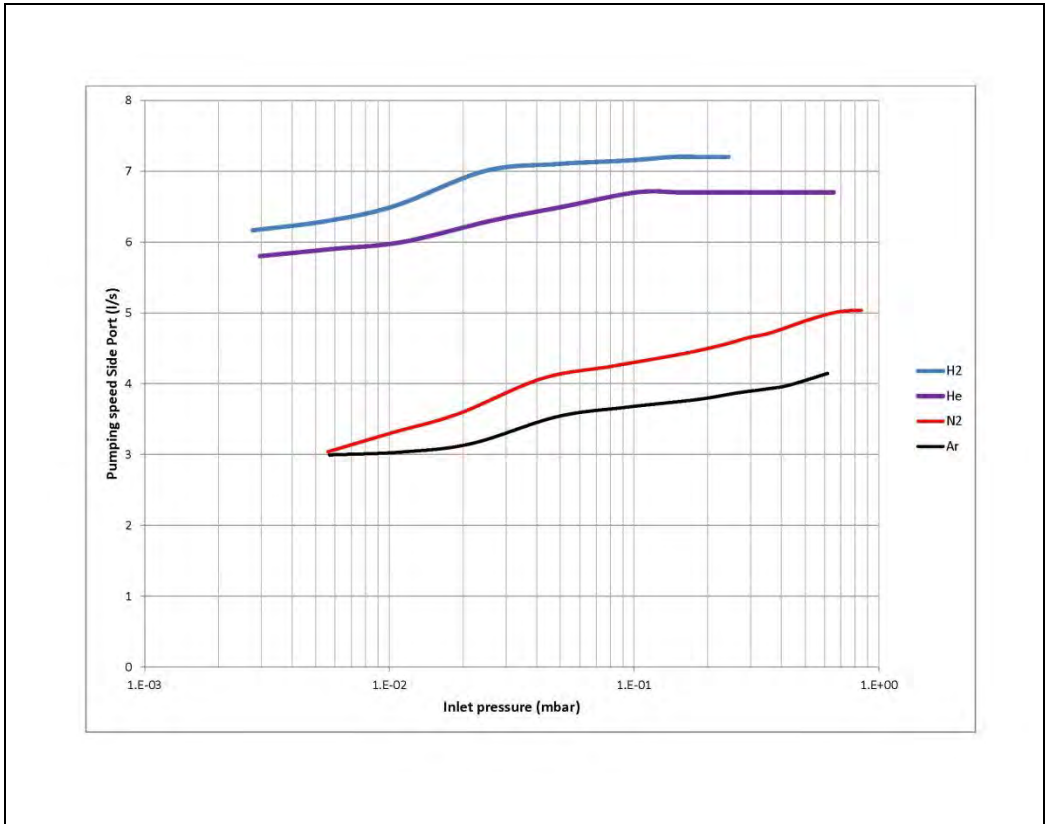

Figure 29 Split Flow (X3500-64010): Graph of Pumping Speed (Side Port KF4)

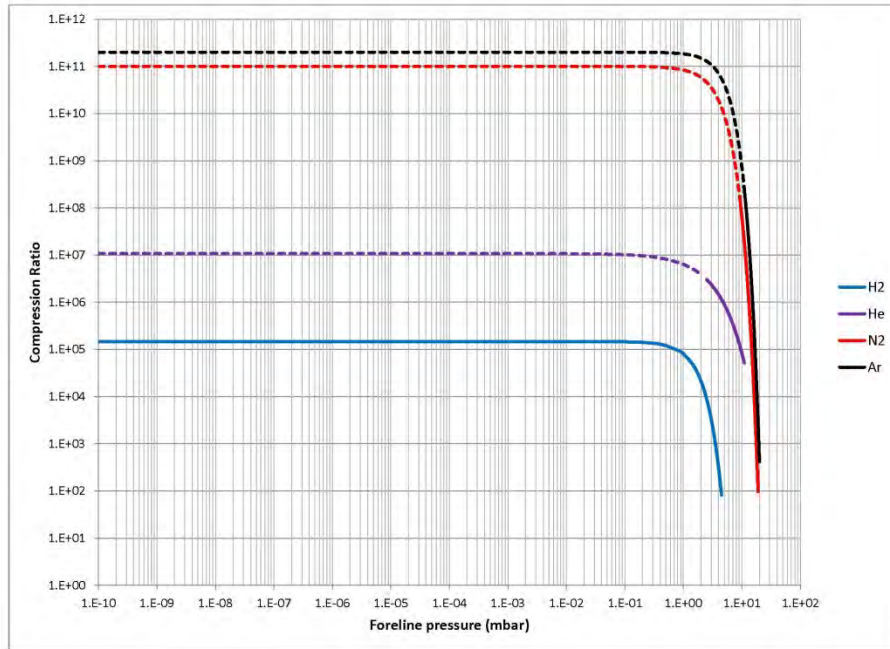

Figure 30 Split Flow (X3500-64010): Graph of Compression Ratio (Total)

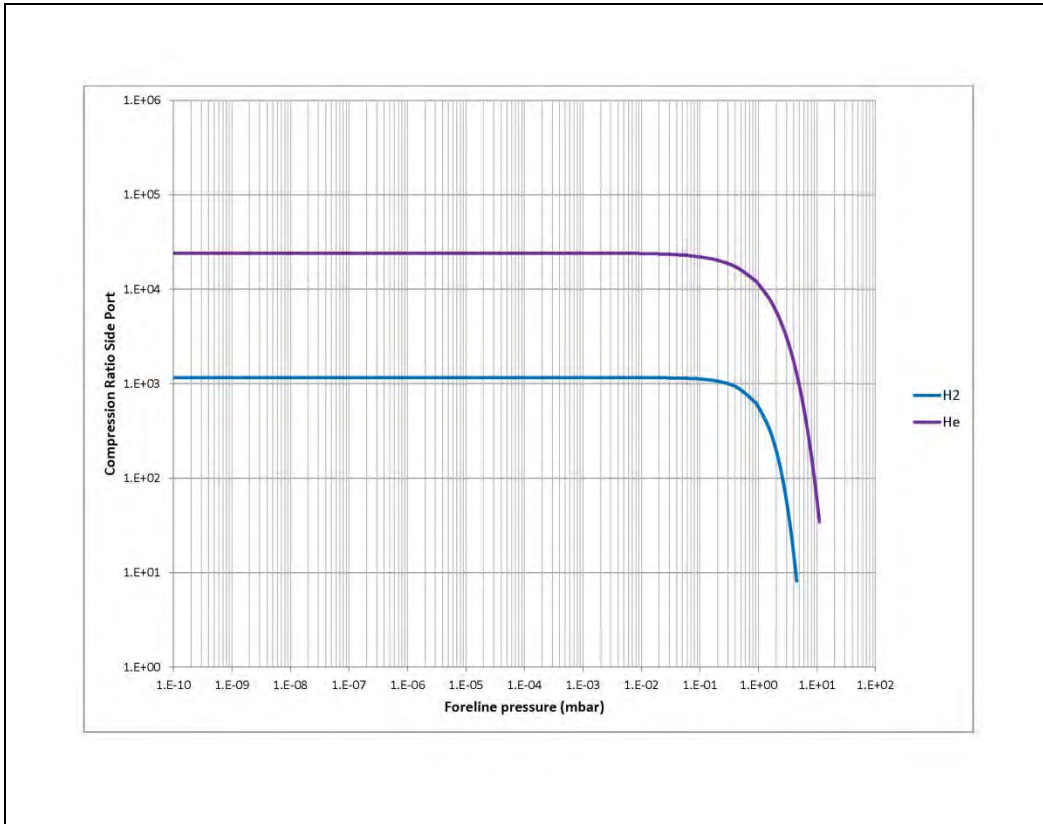

Figure 31 Split Flow (X3500-64010): Graph of Compression Ratio (Foreline/Side port)

Interconnections

The following figure shows the TwisTorr 304 FS interconnections.

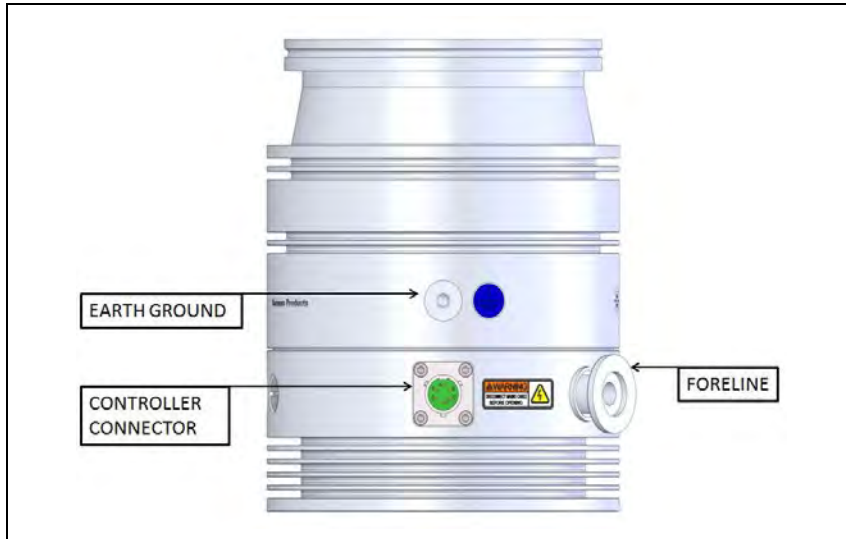

Figure 32

Earth (Ground) Connection

We recommend that you fit a separate earth (ground) conductor to the TwisTorr 304 FS. Use a separate insulated green/yellow conductor, and use a M5 x 10 screw and shake proof washer (fitted to the earth hole on the pump) to secure the earth conductor to the pump. The screw must be fixed with a 2 Nm torque.

The impedance between the pump-body and the earth connection point must be $< 0.1 \Omega$.

Connection C – Electrical

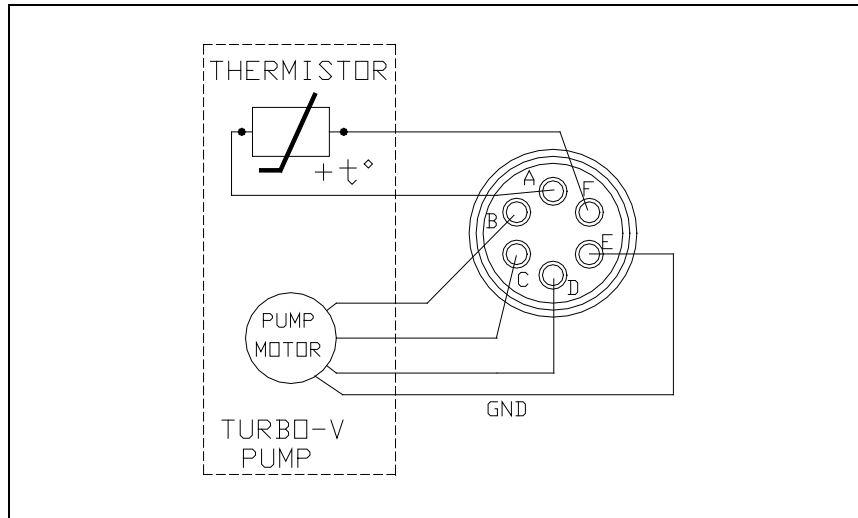

Figure 33

The turbopump is connected to the controller through an 6-pin connector. Pins B, C and D are the 3-phase supply to the motor, pins A and F are connected to the temperature sensor (NTC type, 30 K Ω resistance at 25 °C) and pin E is connected to the pump ground.

If the temperature sensor is disconnected, the pump will not start. To prevent damage to the pump when the temperature exceeds 60 °C, the sensor automatically cuts out the power supply.

Soft Start

“Soft Start” mode is provided to start the pump after a protracted stop of the TwisTorr 304 FS. This allows a better grease distribution in the bearings.

The “Soft Start” mode is disabled by default.

To enable the “Soft Start” mode it must be activated by the suitable software or Remote I/O command (see Controller Manual).

“Soft Start” frequency steps are as follow: 300 Hz, 400 Hz, 800 Hz, 900 Hz. For more details see Controller Manual.

Inlet screen installation

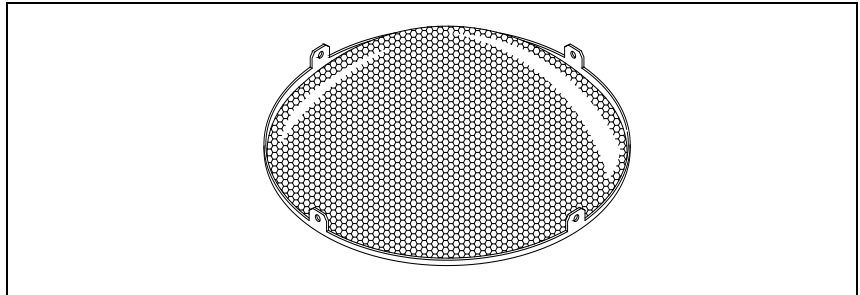

Figure 34 Model 969-9302 and 969-9303



Figure 35 Model X3500-68000 and X3500-68001

The inlet screens mod.

- X3500-68000 (ISO 100)
- X3500-68001 (ISO 160)
- 969-9302 (CFE 6")

- 969-9304 (CFE 8")

prevent the blades of the pump from being damaged by debris. The inlet screen, however, does reduce the pumping speed as followed:

Reduction in pumping speed (%)				
	Ar	N ₂	He	H ₂
X3500-68000				
X3500-68001	20%	18%	7%	5%

The inlet screen is fitted in the upper part of the pump, as shown in the figure.



Figure 36

The screen can be mounted on each pump.

The screen can be removed as shown in the following figure.



Figure 37

The overall flange dimensions with the protection screen fitted on pump do not change as the inlet screen remains integrated into the center-ring.

Air Cooling Kit Installation

An air cooling kit (X3500-68011) is available to improve the TwisTorr 304 FS cooling during operational conditions.

Fan specifications:

- air flow: 147 m³/h
- input voltage: 24 Vdc
- dimensions: 119 x 119 x 32 mm (4.7 x 4.7 x 1.3 in.)
- power: 2.6 W

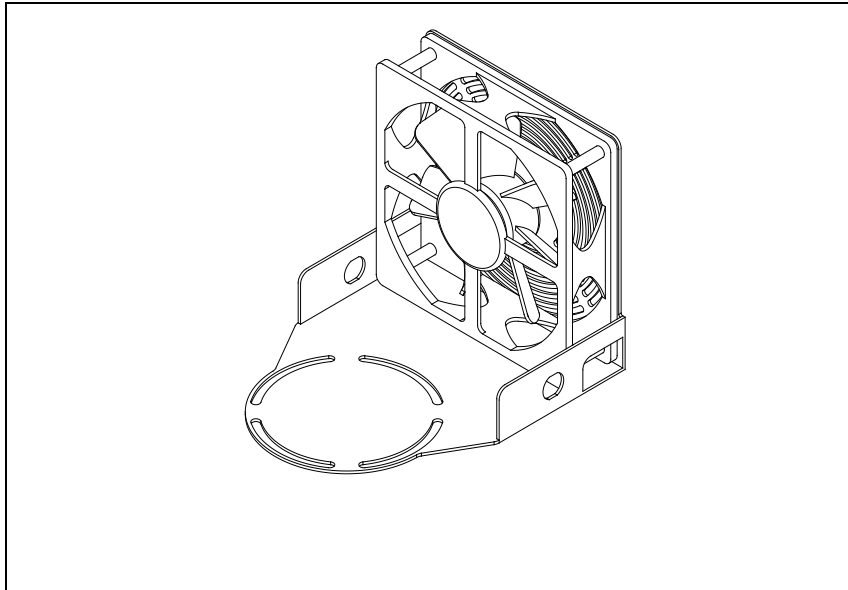

Figure 38

The fan bracket is shaped so that it can be mounted close to the pump. When the pump is supplied by the rack C.U. , please utilize the special fan extension cable 969-9949.

To fix the fan to the TwisTorr 304 FS case execute the following procedure (see the following figure):

- 1 Fix the fan to the suitable bracket by means of the furnished screws;
- 2 Fix the bracket to the pump body between the pump and the controller;
- 3 Connect the fan supply to the P4 connector of the controller.

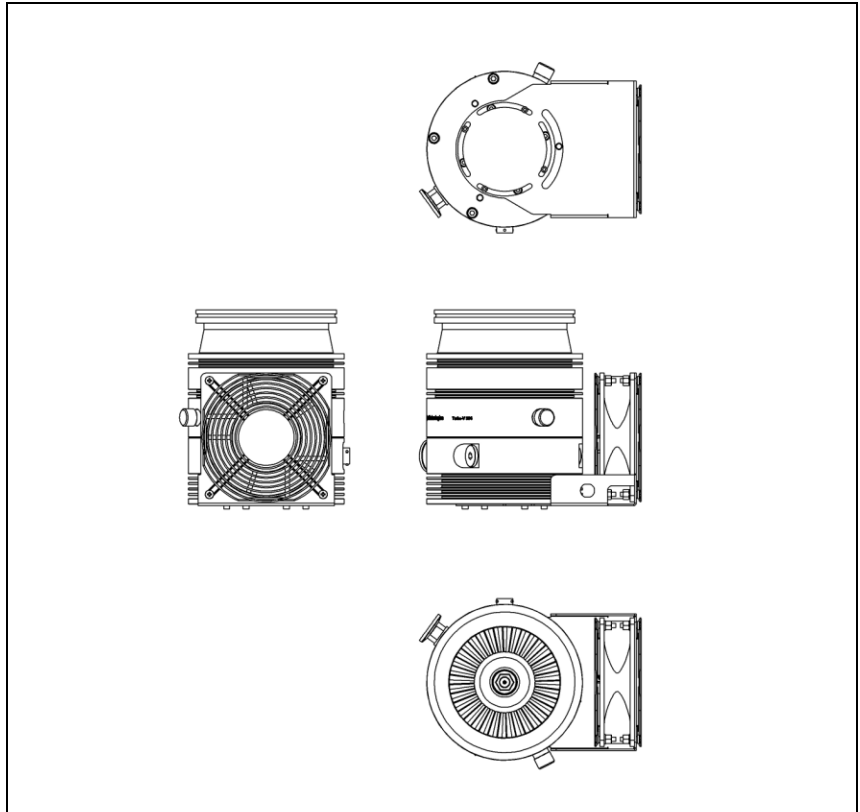

Figure 39

Water Cooling Kit Connection

Two types of water cooling kits are available to be mounted when the pump is used under heavy load conditions or when air cooling is insufficient.

The two model part numbers are: 969-9337 (metallic model), and 969-9347 (plastic model).

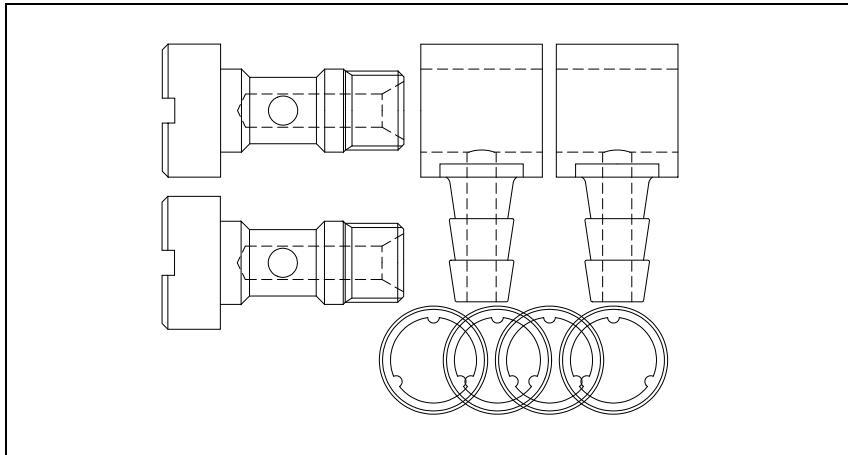

Figure 40 Model 969-9337

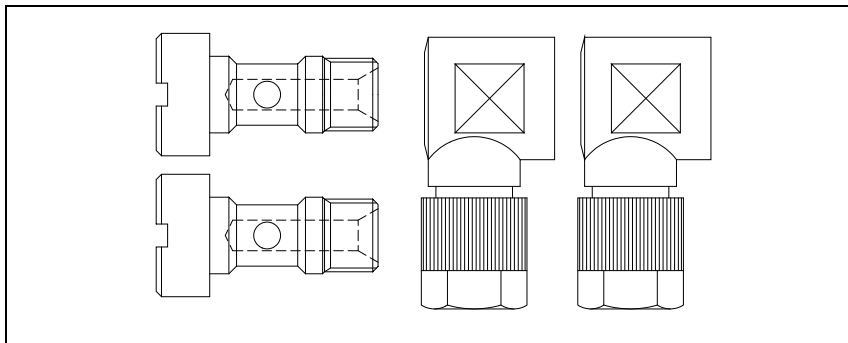

Figure 41 Model 969-9347

CAUTION!

The items of the plastic model kit must be assembled as shown in the following figure

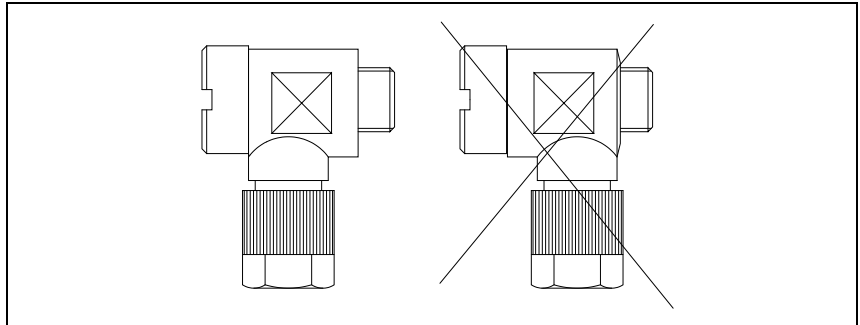

Figure 42

The assembled kit must be screwed into the suitable holes of the pump body with a recommended closing torque of 5 Nm.

The metallic model is assembled as shown in the figure.

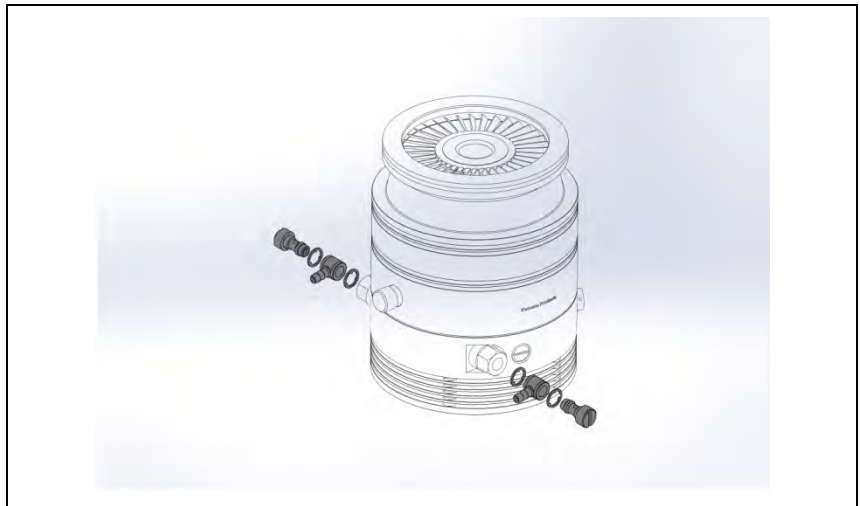

Figure 43

Two 6 mm (1/4") internal diameter rubber or plastic hoses from the water supply must be fitted to the two nozzles.

NOTE

These hoses must be held on the respective nozzles using hose clips to avoid that the tube(s) gets loose or disconnected during operation.

Cooling may be carried out either through an open circuit with eventual discharge of the water, or using a closed circuit cooling system.

The water temperature must be between +15 °C and +30 °C, with an inlet pressure between 3 and 5 bar. This allows a flow higher than 50 l/h.

NOTE

The water electrical conductance must be $\leq 500 \mu\text{s}/\text{cm}$. When the conductance is higher, in closed water circuit, the use of up to 20 % of Ethyl-Glycole is suggested.

Vent Accessories

The vent valve and vent device allow to avoid undesired venting of the pump during temporary power failure and enables an automatic vent operation.

TwisTorr 304 FS on board controller compatible Vent Valve mod. 969-9834

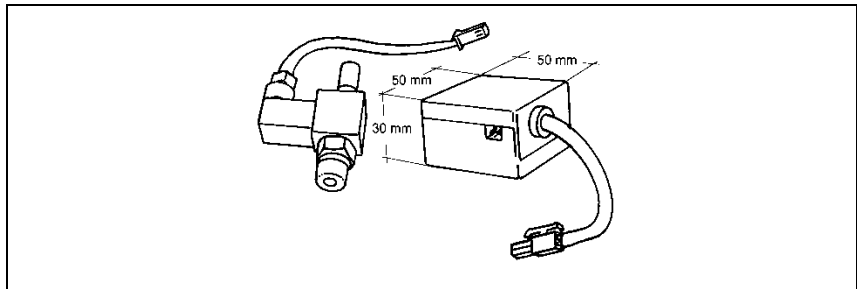

Figure 44

This vent valve waits before opening a minimum time of about 5 sec. This time can be increased up to about 220 min. by means of a setting of the controller software (optional).

To install the vent valve, unscrew the threaded plug (see figure below).



Figure 45

Then screw the vent valve into the pump and tighten it using a 16 mm hexagonal spanner with a torque of 2.5 Nm.

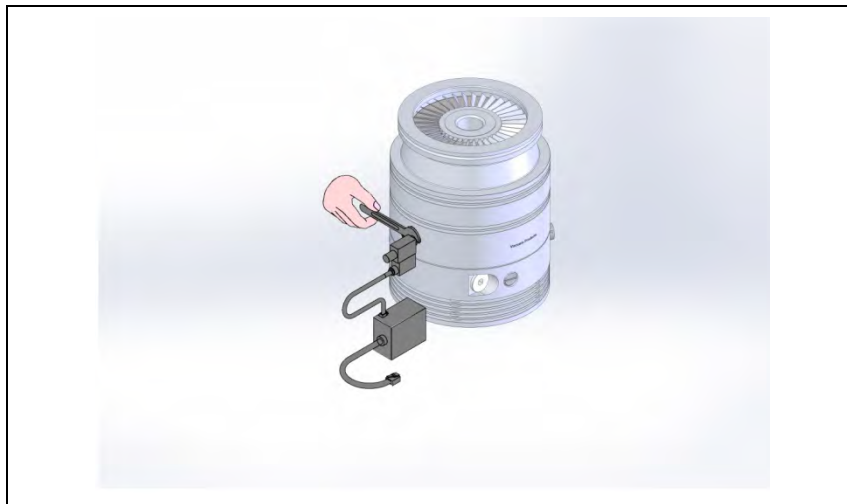

Figure 46

CAUTION!

Do not overtighten the valve as this may damage the thread on the pump.

Then connect the cable from the valve to the suitable connector on the controller.

TwisTorr 304 AG Rack Controller Compatible Vent Valve mod. 969-9844

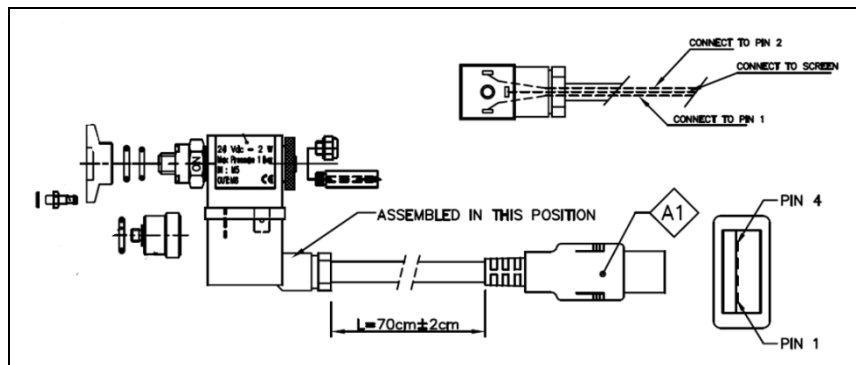

Figure 47

For further details refers to the Rack Controller manual.

To install the vent valve unscrew and remove the threaded plug (see figure below).



Figure 48

Screw the flange mod. 969-9108 on the pump, taking care of the oring right position.

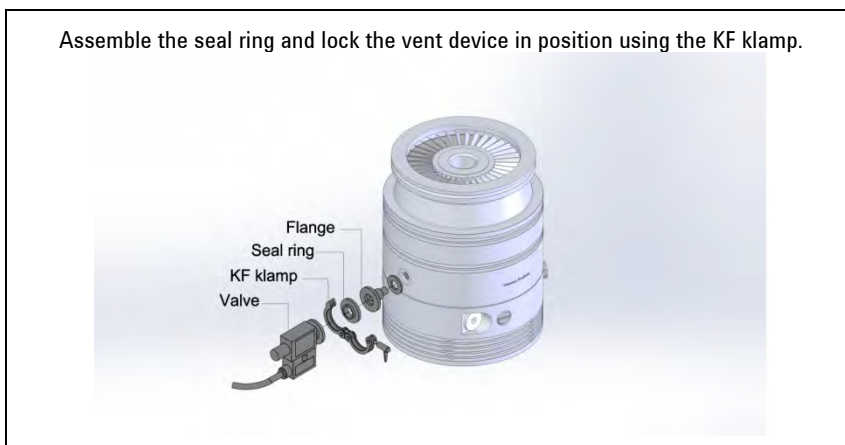

Figure 49

Vibration Isolator Installation

Four vibration isolators for ISO and CFF inlet flange version pumps are available as accessories.

The four model part numbers are the following:

- model 969-9344 for ISO 100 flange;
- model 969-9345 for ISO 160 flange;
- model 969-9334 for CFF 6" flange;
- model 969-9335 for CFF 8" flange.

They typically reduce the vibration transmitted from the TwisTorr 304 FS to the system by a factor of 20.

Please refer to the relevant instruction manual.

Purge Valve Installation

A gas purge valve is available to protect the pump bearings against particulate and corrosive gases that could move into the pump. To install the gas purge valve it is necessary to unscrew the purge port cover as shown in the following figure,



Figure 50

and then screw the gas purge valve (with a torque of 2.5 Nm) as shown in the following figure.



Figure 51

TwisTorr 304 FS On-board Controller Installation

The controller can be mounted in two position:

- bottom mounting (as per the complete system)
- side mounting.

To install the controller execute the following procedures.

Bottom Mounting

See the following figure.

- 1** Turn the pump upside-down;
- 2** Screw the 4 fixing studs (provided with the accessories bag) in the holes on the bottom of pump;
- 3** Place the controller on the studs aligning the 4 rubber holes on the top of the controller case;
- 4** Press the controller towards the pump;
- 5** Turn the pump again;
- 6** Plug the line cord and connect the pump cable to the pump;
- 7** Connect the mating connector with the jumper on the interlock signal to start the pump.

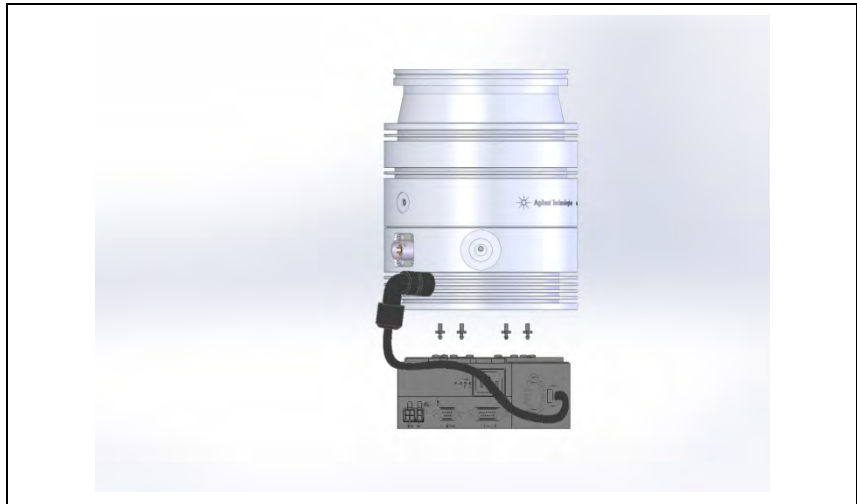

Figure 52 Mounting 1

Side Mounting

NOTE

The L-shaped bracket (P/N X3500-68012) is available as an option.

See the following figure.

- 1 Screw the 4 fixing studs (provided with the accessories bag) in the holes on the L-shaped bracket;
- 2 Place the controller on the studs aligning the 4 rubber holes on the top of the controller;
- 3 Press the controller towards the bracket;
- 4 Turn the pump upside-down;
- 5 Place the bracket on the pump bottom;
- 6 Screw a little bit the three screws M4 in the holes on the pump bottom;
- 7 Rotate the bracket until the controller is on the chosen position;

- 8 Tighten the screws properly;
- 9 Turn the pump again;
- 10 Plug the line cord and connect the pump cable to the pump;
- 11 Connect the mating connector with the jumper on the interlock signal to start the pump.

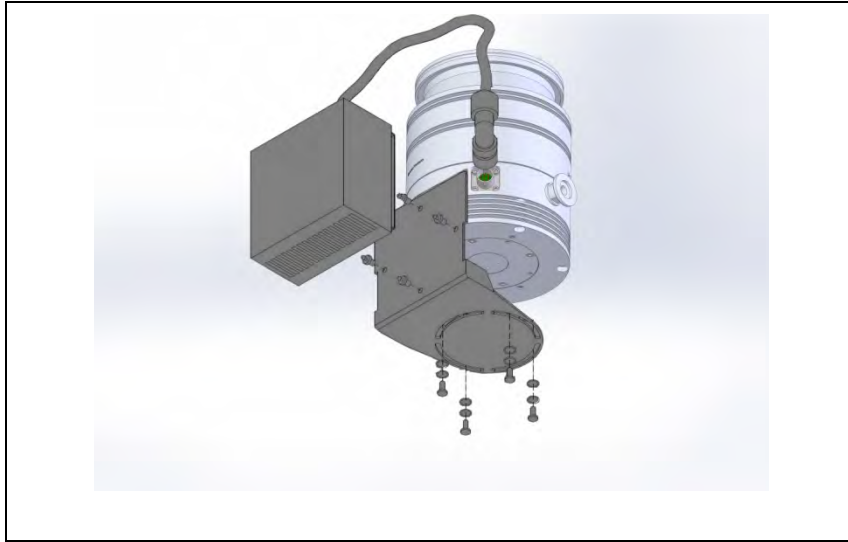

Figure 53 Mounting 2

Connection of the High Vacuum Flange

In the case the rotor is suddenly blocked, the torque arising from the system and the high vacuum flange must be absorbed. Only the components listed in the following can be used to fasten the pump to the high vacuum flange.

WARNING!



It is mandatory to connect the pump in such a way to withstand the torque specified in the "INSTRUCTION FOR USE" section. Specifically pay attention to clamp design, material of clamps and bolts and bolt fixing torque.

WARNING!



If the pump is fastened on a vacuum chamber with different flange Agilentts there exists the chance of twisting or tearing-off in case the rotor is suddenly blocked. The combination of different flange types is not allowed in any case. Agilent Vacuum will not accept any liability for all damages resulting from not allowed fastening.

Installation of ISO-K Flange

For ISO-K flange connections, fix the two flanges with the clamps as shown in the following figure (a protective screen can optionally be used).

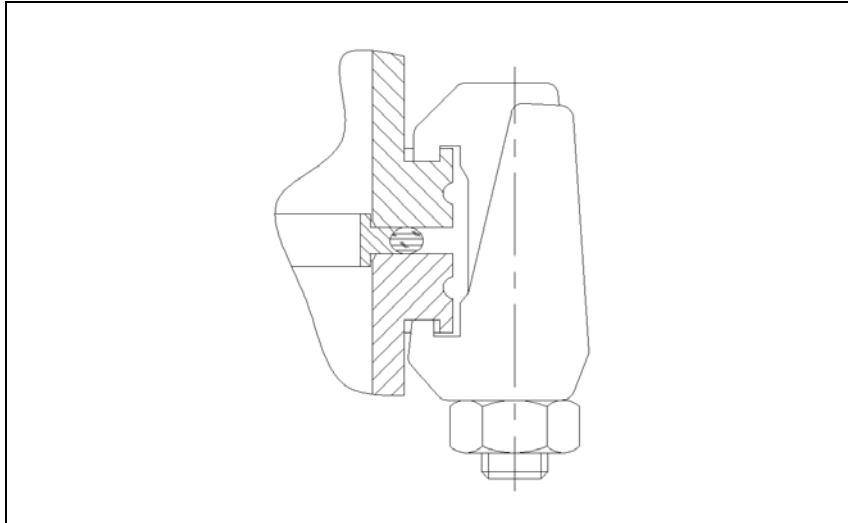

Figure 54

Use the required number of claw clamps:

- 4 for ISO 100 flange
- 4 for ISO 160 flange

Tighten the claw clamps with a torque of 22 Nm.

Installation of ConFlat Flange

For ConFlat flange connections, fix the two flanges with the screws as shown in the following figures (a protective screen can optionally be used).

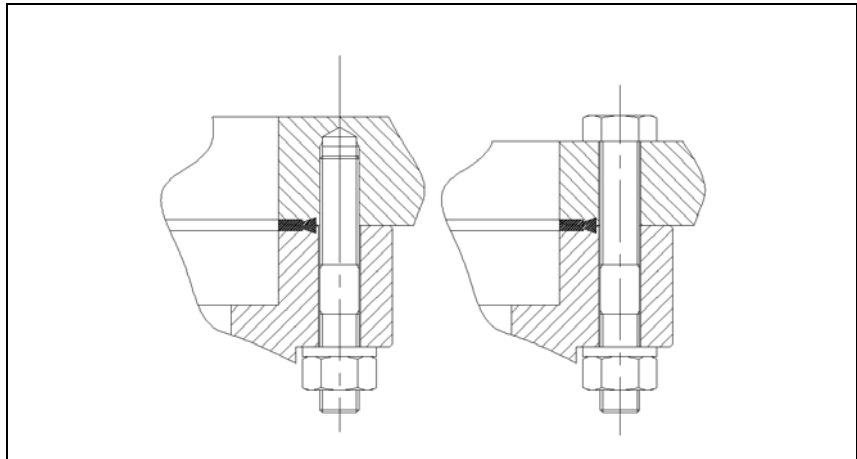

Figure 55

Use the required number of screws:

- 16 for CFF 6"
- 20 for CFF 8"

Attach the units and tighten each screw in turn. Repeat the sequential tightening until the flange faces meet. Tighten the screws with a torque of 20 Nm.

For ConFlat flange connections we recommend using Agilent hardware.

To facilitate assembly and dismantling, apply Felpro C-100 high temperature lubricant to the screw threads protruding from the flange and between the nuts and flange.

Note that, in some cases, the connections can be made only with the bolt in the lower side.

CAUTION!

Exercise care when tightening nuts and bolts to avoid creating dents in the envelope as this may cause the pump rotor to lock.

Connection of the Fore-Vacuum Pump

A flange KF 16 NW is available to connect the TwisTorr 304 FS pump to the forevacuum pump. A hose or vacuum approved pipe can be used. If a rigid pipe is used, any vibration generated by the mechanical pump must be eliminated through the use of bellows.

NOTE

The TwisTorr 304 pump is characterized by its high compression ratio also for oil vapors. When using a mechanical oil-sealed pump, it is advisable to install a suitable trap between the turbopump and the fore-vacuum pump in order to prevent oil back-streaming.

Pump Used with Corrosive Gases

To prevent damage to the bearings, an inert gas must flow into the pump body around the upper bearing towards the forevacuum line. To supply the inert purge gas (e. g. nitrogen) to the pump through the purge port, connect a gas purge valve between the pressure regulator and the pump.

Adjust the pressure regulator in order to read a gas flow rate of 0.1 to 0.8 mbar l/s.

CAUTION!

To prevent bearing damage, Agilent suggests a minimum purge gas flow rate of 10 sccm (0.17 mbar l/s). This value can be exceeded, according to the process requirements. Please contact Agilent for specific applications.

The purge gas throughput with the recommended forepump of 15 m³/h (11 CFM) allows to achieve a high vacuum pressure in the 10-8 mbar range. The recommended gas flow maintains a pressure into the pump body higher than the forevacuum pressure. The recommended procedure to vent the system and the pump avoiding the contact between the pump bearings and the corrosive gas is described in the following points:

- 1 Close the corrosive gas flow into the system.
- 2 Leaving the Turbo pump and the backing pump running and the purge gas flowing, wait for enough time to evacuate the corrosive gas from the system.
- 3 Turn off the Turbopump.
- 4 Open the Turbo vent port slowly until to reach atmospheric pressure in the system.
- 5 When the Turbo pump and the backing pump are stopped and the system is at atmospheric pressure, for a better bearing protection it is advisable to leave the purge gas flowing into the Turbo pump, with the chamber or the Turbo vent valve opened, to avoid system overpressures. If the vent valve can't be kept opened, the backing pump should be left operating.

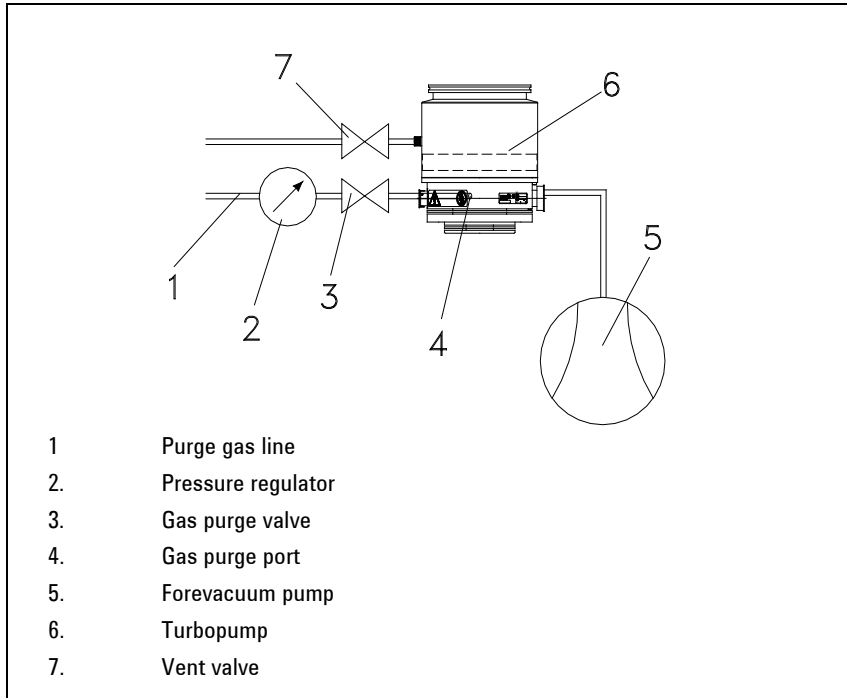

Figure 56 Purge layout

Pump Used in Presence of Magnetic Fields

Magnetic fields induce eddy currents in the rotor of a turbomolecular pump that tend to oppose to its rotation.

The result is increased electrical power consumption by the motor, most of which is dissipated in the rotor.

Since the rotor is not in contact with the stator the above power can leave the rotor mainly by radiation and hence the rotor may be overheated while static parts of the pump remain cool.

This effect is strongly dependant from the intensity, time function and distribution of the magnetic field.

In general, therefore, an increase in pump current can be expected.

If this increase is lower than 50 % of the current value drawn by the motor in high vacuum operation, no particular problem should be expected.

However if the effect is grater, than the case should be carefully reviewed by Agilent's specialist. As a matter of fact, in case of high magnetic fields, also important forces might be generated and applied to the rotor.

Accessories and Spare Parts

Tab. 5 Accessories and spare parts

DESCRIPTION	PART NUMBER
Mains cable NEMA Plug, 3m long	969-9958
Mains cable European Plug, 3m long	969-9957
Serial cable and Navigator Software	969-9883
Inlet screen, ISO 100	X3500-68000
Inlet screen CFF 6''	696-9302
Inlet screen, ISO 160	X3500-68001
Inlet screen CFF 8''	696-9304
Water cooling kit	969-9337
Plastic water cooling kit	969-9347
Air cooling kit for On-board Controller	X3500-68010
Air cooling kit for Rack AG Controller	X3500-68011
Fan extension cable	969-9949
Bracket for On-Board Controller side mounting	X3500-68012
Vibration isolator, ISO 100	969-9344
Vibration isolator, CF 6"	969-9334
Vibration isolator, ISO 160	969-9345
Vibration isolator, CF 8"	969-9335
Vent flange, NW 10 KF / M8	969-9108
Vent valve for AG Rack Controller	969-9844
Vent valve for on-board Controller	969-9834
Purge valve 10 SCCM NW16KF – M12	969-9239
Purge valve 10 SCCM ¼ Swagelok – M12	969-9240
Purge valve 20 SCCM NW16KF – M12	969-9241
Purge valve 20 SCCM ¼ Swagelok – M12	969-9242
Purge valve 10 SCCM ¼ Swagelok – ¼ Swagelok	9699232
Purge valve 20 SCCM ¼ Swagelok – ¼ Swagelok	9699236
Foreline flange KF25 1/4 gas	969-9130
Active Gauges	Ask Agilent for details



Vacuum Products Division

Dear Customer,

Thank you for purchasing an Agilent vacuum product. At Agilent Vacuum Products Division we make every effort to ensure that you will be satisfied with the product and/or service you have purchased.

As part of our Continuous Improvement effort, we ask that you report to us any problem you may have had with the purchase or operation of our products. On the back side you find a Corrective Action request form that you may fill out in the first part and return to us.

This form is intended to supplement normal lines of communications and to resolve problems that existing systems are not addressing in an adequate or timely manner.

Upon receipt of your Corrective Action Request we will determine the Root Cause of the problem and take the necessary actions to eliminate it. You will be contacted by one of our employees who will review the problem with you and update you, with the second part of the same form, on our actions.

Your business is very important to us. Please, take the time and let us know how we can improve.

Sincerely,

Giampaolo LEVI

*Vice President and General Manager
Agilent Vacuum Products Division*

CUSTOMER REQUEST FOR CORRECTIVE / PREVENTIVE / IMPROVEMENT ACTION

www.turbovac.com.cn 中山共孚电子真空技术有限公司

TO: AGILENT VACUUM PRODUCTS DIVISION TORINO – QUALITY ASSURANCE

FAX N°: XXXX-011-9979350

ADDRESS: AGILENT TECHNOLOGIES ITALIA S.p.A. – Vacuum Products Division –

Via F.lli Varian, 54 – 10040 Leini (TO) – Italy

E-MAIL: vpd-qualityassurance_pdl-ext@agilent.com

NAME _____	COMPANY _____	FUNCTION _____
ADDRESS: _____		
TEL. N° : _____ FAX N° : _____		
E-MAIL: _____		
PROBLEM / SUGGESTION : _____ _____ _____ _____		
REFERENCE INFORMATION (model n°, serial n°, ordering information, time to failure after installation, etc.): _____ _____ _____		
		DATE _____
CORRECTIVE ACTION PLAN / ACTUATION (by AGILENT VPD) _____ _____ _____ _____ _____		LOG N° _____

XXX = Code for dialing Italy from your country (es. 01139 from USA; 00139 from Japan, etc.)



Agilent Technologies

Vacuum Products Division Instructions for returning products

Dear Customer:

Please follow these instructions whenever one of our products needs to be returned.

- 1) Complete the attached Request for Return form and send it to Agilent Technologies (see below), taking particular care to identify all products that have pumped or been exposed to any toxic or hazardous materials.
- 2) After evaluating the information, Agilent Technologies will provide you with a Return Authorization (RA) number via email or fax, as requested.
Note: Depending on the type of return, a Purchase Order may be required at the time the Request for Return is submitted. We will quote any necessary services (evaluation, repair, special cleaning, eg).
- 3) **Important steps for the shipment of returning product:**
 - Remove all accessories from the core product (e.g. inlet screens, vent valves).
 - Prior to shipment, drain any oils or other liquids, purge or flush all gasses, and wipe off any excess residue.
 - If ordering an Advance Exchange product, **please use the packaging from the Advance Exchange to return the defective product.**
 - Seal the product in a plastic bag, and package product carefully to avoid damage in transit. You are responsible for loss or damage in transit.
 - Agilent Technologies is not responsible for returning customer provided packaging or containers.
 - **Clearly label package with RA number.** Using the shipping label provided will ensure the proper address and RA number are on the package. Packages shipped to Agilent without a RA clearly written on the outside cannot be accepted and will be returned.
- 4) Return only products for which the RA was issued.
- 5) **Product being returned under a RA must be received within 15 business days.**
- 6) **Ship to the location specified on the printable label, which will be sent, along with the RA number, as soon as we have received all of the required information.** Customer is responsible for freight charges on returning product.
- 7) Return shipments must comply with all applicable **Shipping Regulations** (IATA, DOT, etc.) and carrier requirements.

RETURN THE COMPLETED **REQUEST FOR RETURN** FORM TO YOUR NEAREST LOCATION:

EUROPE:

Fax: 00 39 011 9979 330
Fax Free: 00 800 345 345 00
Toll Free: 00 800 234 234 00
vpt-customer@agilent.com

NORTH AMERICA:

Fax: 1 781 860 9252
Toll Free: 800 882 7426, Option 3
vpl-ra@agilent.com

PACIFIC RIM:

please visit our website for individual office information
<http://www.agilent.com>



Vacuum Products Division
Request for Return Form
(Health and Safety Certification)

Please read important policy information on Page 3 that applies to all returns.

1) CUSTOMER INFORMATION

Form with fields: Company Name, Contact Name, Tel, Email, Fax, Customer Ship To, Customer Bill To, VAT reg. Number, USA/Canada only (Taxable/Non-taxable)

2) PRODUCT IDENTIFICATION

Table with 4 columns: Product Description, Agilent P/N, Agilent S/N, Original Purchasing Reference

3) TYPE OF RETURN (Choose one from each row and supply Purchase Order if requesting a billable service)

- 3A. Non-Billable, Billable, New PO # (hard copy must be submitted with this form)
3B. Exchange, Repair, Upgrade, Consignment/Demo, Calibration, Evaluation, Return for Credit

4) HEALTH and SAFETY CERTIFICATION

AGILENT TECHNOLOGIES CANNOT ACCEPT ANY PRODUCTS CONTAMINATED WITH BIOLOGICAL OR EXPLOSIVE HAZARDS, RADIOACTIVE MATERIAL, OR MERCURY AT ITS FACILITY. Call Agilent Technologies to discuss alternatives if this requirement presents a problem. The equipment listed above (check one): HAS NOT pumped or been exposed to any toxic or hazardous materials. OR HAS pumped or been exposed to the following toxic or hazardous materials. List all toxic/hazardous materials. Include product name, chemical name, and chemical symbol or formula.

5) FAILURE INFORMATION:

Failure Mode (REQUIRED FIELD. See next page for suggestions of failure terms):
Detailed Description of Malfunction: (Please provide the error message)
Application (system and model):

I understand and agree to the terms of Section 6, Page 3/3.
Print Name: Authorized Signature: Date: