

# LDS2010

Helium and Hydrogen Leak Detector

SPEEDING UP YOUR LEAK DETECTION PROCESS



# Fast · Reliable · Repeatable

**Integrate the INFICON LDS2010 into an industrial leak-detection system and you will find everything you are looking for in a modular helium/hydrogen leak detector: accuracy, stability, repeatability, minimal maintenance, low cost of ownership and ease-of-use.**

## SET IT - AND FORGET IT

It is difficult to ensure repeatability if a leak detector requires frequent repairs or excessive maintenance. Designed for long-term stability and incorporating intelligent, automatic adjustment, the LDS2010 provides high reliability with minimal maintenance required. In addition, the LDS2010 is the only leak detector with ion-source filaments guaranteed to last for at least three years. The INFICON 3-year guarantee is unmatched and it means much more than saving money on filaments. Comprehensive system monitoring and premium filaments are fundamental for high up-time, low cost of ownership, temperature stability and long term system stability.

## FLEXIBLE

Adaptable to all test system configurations, the LDS2010 offers fast and repeatable results under any test condition. Many features make LDS2010 integration versatile and easy. The fit anywhere design can be configured in ULTRA, FINE, GROSS and SNIFFER modes.

Wide sensitivity ranges in each mode allows for flexible testing techniques. Simple and infrequent preventive maintenance (PM) offers flexibility in machine layout to maximize performance and packaging. Excellent linearity provides the opportunity to run a wide range of parts with different leak rate requirements without recalibrating at each point.

## SMART AND SAFE

The LDS2010 can be calibrated within the test system in several ways. Using the optional internal calibrated leak, a simple to use automatic internal mass spec tune and calibration can be performed. It also features an automation friendly external mass spec tune and system calibration. Both the internal and external calibration routines include a built-in signal to background level confirmation to ensure a valid calibration occurs. The LDS2010 also offers a dynamic calibration which provides system calibration under test cycle conditions.

The LDS2010 offers complete system monitoring and self-diagnostics. The unit carefully monitors and controls critical parameters during operation. System-Ready and System-Fail signals are communicated to the test system to ensure testing occurs only when the leak detector is ready. Diagnostic codes are provided for easy troubleshooting.

The efficient turbomolecular pump and its integrated electronics work to maximize your uptime. The on-board controller drives, monitors and controls the turbo pump for ease of use in your operation.

LDS2010 menus and machine adjustments are controlled by a key access system. Set it, lock it and forget about it.

## VERSATILE COMMUNICATION TO MEET YOUR NEEDS

The LDS2010 offers a complete range of relay and analog inputs and outputs for PLC control and a host of digital interface connections for PC control. Control and data acquisition is available via analog I/O, RS232 and RS485 communication ports. With optional fieldbus converters, the LDS2010 can be controlled via common fieldbus protocols.

The LDS2010 has many analog output options. In many cases, this unit can be retrofitted into an existing leak detection system without adjusting scaling factors in the PLC.

## SYSTEM SCHEMATICS

PLC / RS232 / RS485 / Profibus interface  
with optional converter

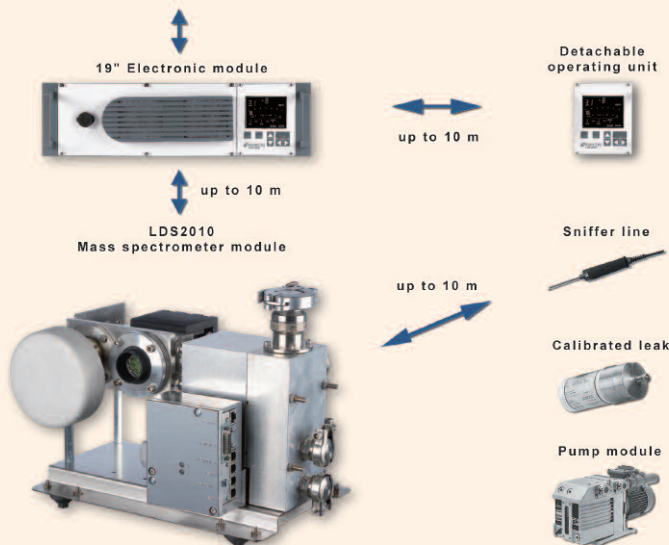

# Stable and Smart

## ADVANTAGES

- High up-time
- Very low cost of ownership
- Flexible system configurations
- Fast clean-up between test cycles via ULTRA mode using interstage compression or through FINE mode techniques
- Two years warranty (three years warranty on the ion source)
- Extremely accurate reproducibility and repeatability
- High pumping speed for short response times and low partial flow factors.
- Internal and external calibration with automatic tune and built-in signal-to-background confirmation
- Can be used with helium as preferred tracer gas as well as for hydrogen leak detection

Recommended example for the integration of the LDS2010 in industrial leak detection systems:

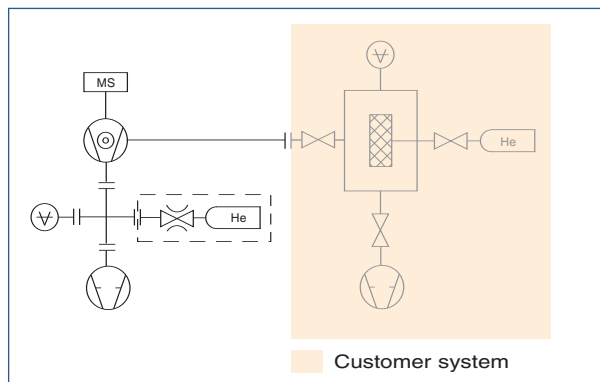

LDS2010 in the ULTRA mode. Optional pump module required.  
Detection limit  $2 \times 10^{-11}$  mbar l/s.

## DIMENSIONS

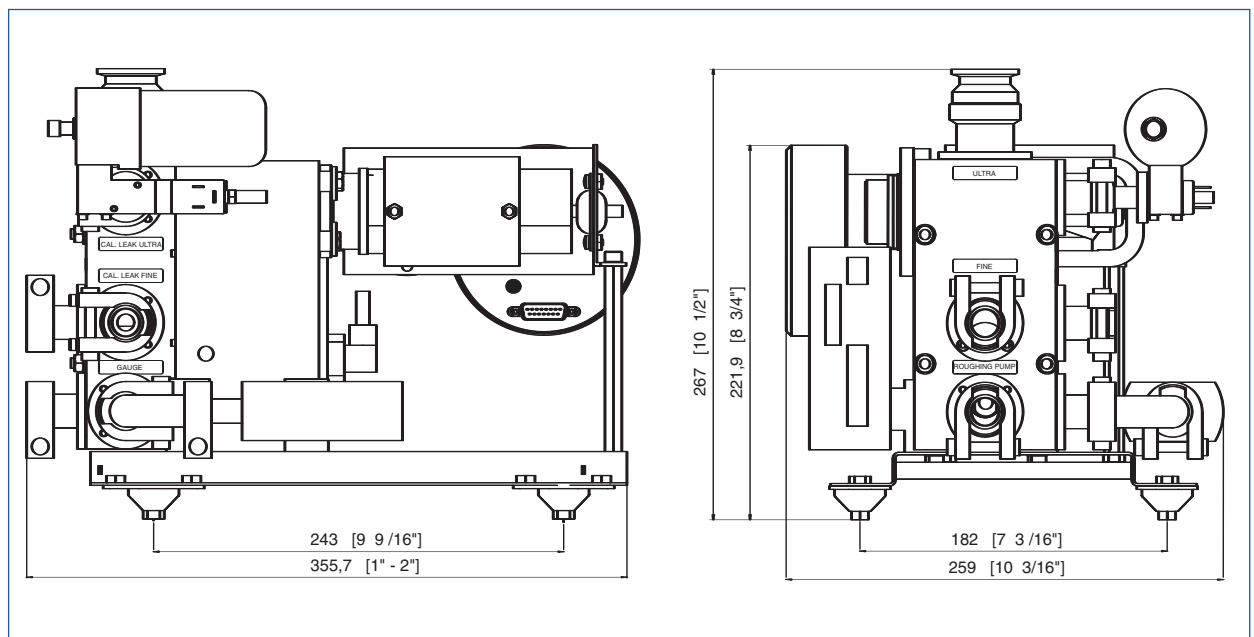

Dimensional drawing of the mass spectrometer module in mm (inch). The electronic module is a standard 19" rack plug-in unit.

## SPECIFICATIONS

Smallest detectable leak rate for helium:		
ULTRA mode	mbar l/s	$\leq 2 \cdot 10^{-11}$ (5 l/s helium pumping speed)
FINE mode	mbar l/s	$\leq 2 \cdot 10^{-10}$ (1.7 l/s helium pumping speed)
GROSS mode	mbar l/s	$\leq 8 \cdot 10^{-8}$
SNIFFER mode	mbar l/s	$\leq 5 \cdot 10^{-8}$
Smallest detectable leak rate for hydrogen:		
ULTRA mode	mbar l/s	$\leq 8 \cdot 10^{-10}$ (6 l/s hydrogen pumping speed)
FINE mode	mbar l/s	$\leq 5 \cdot 10^{-9}$ (2 l/s hydrogen pumping speed)
GROSS mode	mbar l/s	$\leq 5 \cdot 10^{-7}$
Units of measurement (selectable)		mbar l/s, Pa m <sup>3</sup> /s, atm cc/s, g/a, ppm
Max. inlet pressure	mbar	20 mbar (FINE 3 mbar, ULTRA 0,4 mbar)
Response time	s	< 1
Ion source		2 yttrium/iridium longlife cathodes (3 years warranty)
Vacuum connections		DN 16 KF / DN 25 KF
Relays		4
Control inputs		PLC compatible (max. 35 V)
Chart recorder output lin/log	V	0 - 10
Serial interface		RS232, RS485, and Fieldbus options
Dimensions (L x W x H)		
Mass spectrometer module	mm (in.)	348 x 244 x 267 (13.7 x 9.6 x 10.5)
Electronics module	mm (in.)	482.6 x 359.9 x 134.1 (19 x 14.17 x 5.28)
Warranty		2 years (3 years on the ion source)

## ORDERING INFORMATION

	Cat. No.	Options:	Cat. No.
<b>LDS2010</b> consisting of electronic module with integrated operating unit and mass spectrometer	560-100	Pump module (complete with connection accessories) TRIVAC D 4 B, single-phase motor, 230 V, 50/60 Hz	145 11
<b>LDS2010</b> consisting of electronic module with integrated operating unit and mass spectrometer and 10 m cable	560-101	Sniffer valve Sniffer line, incl. handle with sniffer tip, 200 mm Line lengths:	145 20
Connection cable:		3 m (10 ft.)	145 21
Electronic module / mass spectrometer module		5 m (16 ft.)	145 22
1.5 m (4.8 ft.)	560-111	10 m (32 ft.)	145 23
3 m (10 ft.)	560-112	Replacement sniffer probe, 400 mm length 200 04 642	
5 m (16 ft.)	560-113	Connection cable	
10 m (32 ft.) incl. MSV board	560-114	Electronics module / operating unit	
		5 m (16 ft.)	146 40
		10 m (32 ft.)	146 41
		15 m (48 ft.)	146 42
		Internal calibrated leak TL7	145 49
		Profibus converter TIC255	560-021

