

APPLICABLE P. C. BOARD DIMENSION (REF.)
適合基板寸法図 (参考)

TABLE 1.
表1.

PART No. 製 番	A
LPF-SC200SMYG+	10 ^t ×6.5 ^v
LPF-SC200SMYGK+	20 ^t ×6.5 ^v

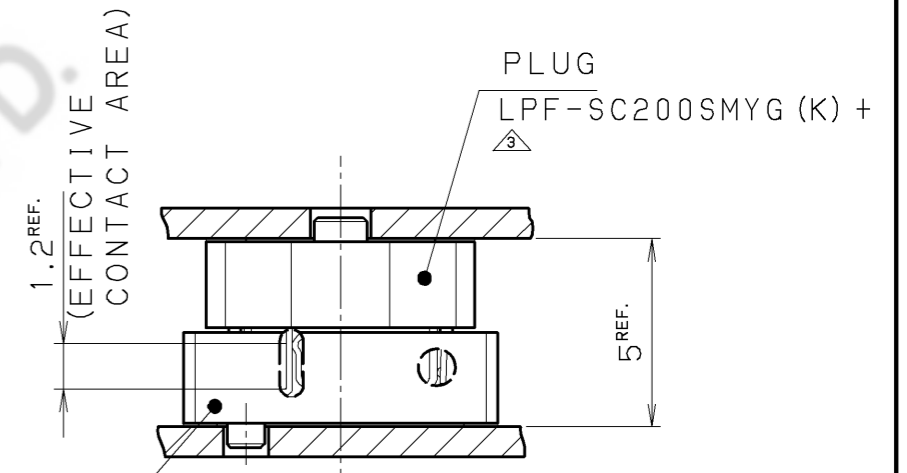
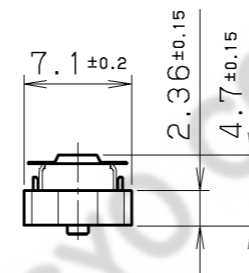

RECEPTACLE
LPF-SC200SFYG (N) +
MATED CONDITION (REF.)
嵌合状態図 (参考)

NOTE 1. COPLANALITY OF SMT TERMINAL IS 0.1 MAX.
注1. SMT部のコプラナリティーは、0.1以下とする。

NOTE 2. THIS SHOWS SURFACE DIMENSION OF SMT TERMINAL.
注2. SMT面の寸法を示す。

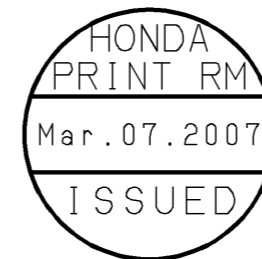

4	耐熱テープ	PI樹脂	1		
	HEAT-RESISTANT TAPE	PI RESIN			
3	シェル	ステンレス鋼	2	リフロー錫メッキ	
	SHELL	STAINLESS		REFLOW TIN PLATING	
2	絶縁体	LCP樹脂	1	UL94V-0 色:黒色	
	INSULATOR	LCP RESIN		UL94V-0 COLOR:BLACK	
1	コンタクト	銅合金	200	接触部:金メッキ 0.76μm以上 SMT部:金フラッシュメッキ CONTACT AREA:GOLD 0.76μm MIN. TERMINAL AREA:GOLD FLASH	

改版 LTR.	年月日 DATE	変更者 BY	変更内容 REV. DESCRIPT	番号 No.	部品名称 PART NAME	材質 MATERIAL	個数 QTY	処 理 FINISH	備 考 NOTE
	01.14 Jan. 14 (2005)	M. Miyazaki	Add Part.						
		S. Iijima	Add HEAT-RESISTANT TAPE						
		M. Miyazaki	Add Dim.						
年月日 DATE			尺度 SCALE	単位 UNIT	3角法	本多通信工業株式会社 HONDA TSUSHIN KOGYO CO., LTD.			
01.14 Jan. 14 (2005)			2/1	mm (INCH)	3RD. A. P				
製 DR.	設 DE.	計 CHK.	検 CHK.	認 APP.	名 称 NAME	PLUG (200 POS. BOARD-TO-BOARD CONNECTOR, 0.5mm PITCH)			
M. MIYAZAKI	M. MIYAZAKI		C. NUNOKAWA	K. KASHIO	製 番 PART NO.	LPF-SC200SMYG (K) + REV. 3C			

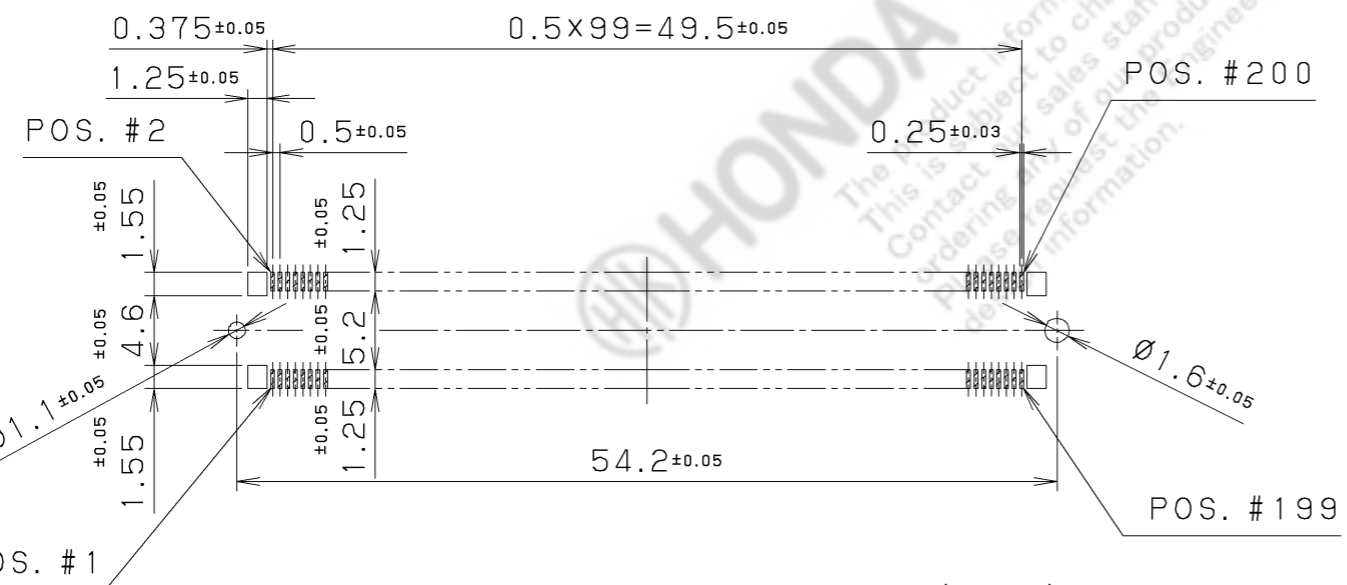
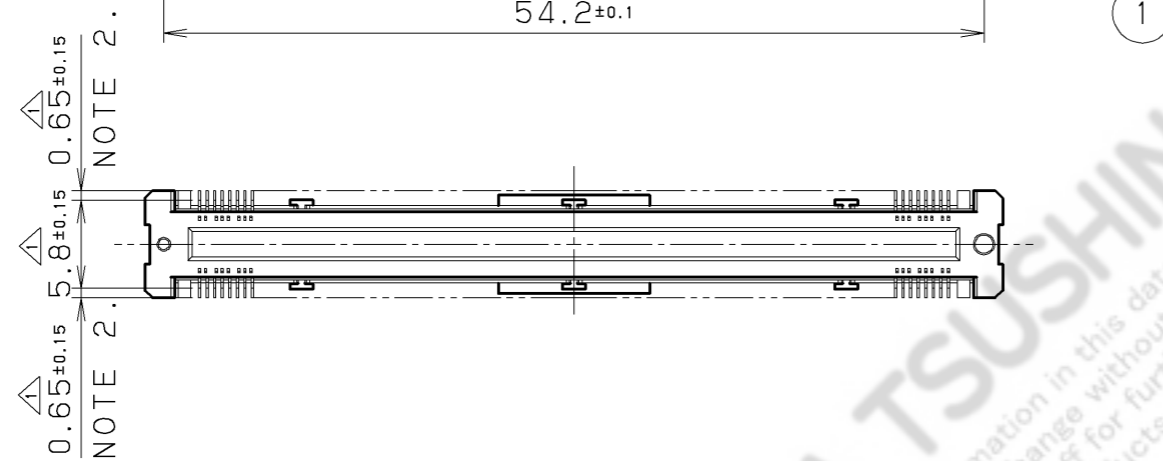
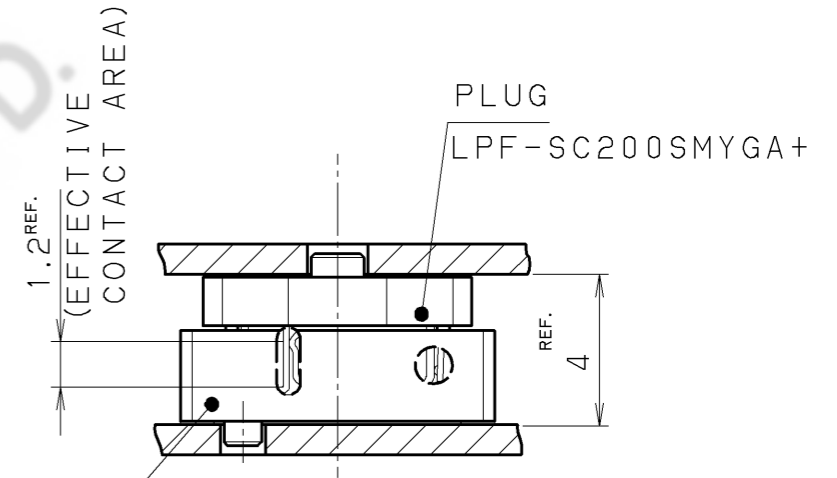
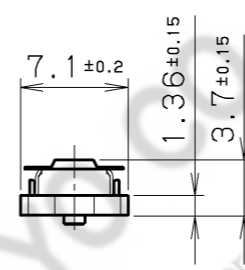
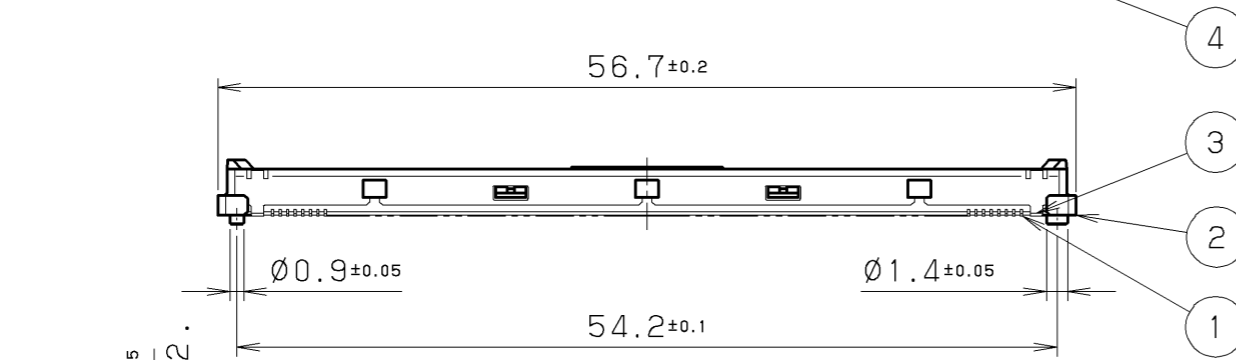
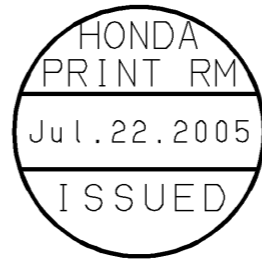
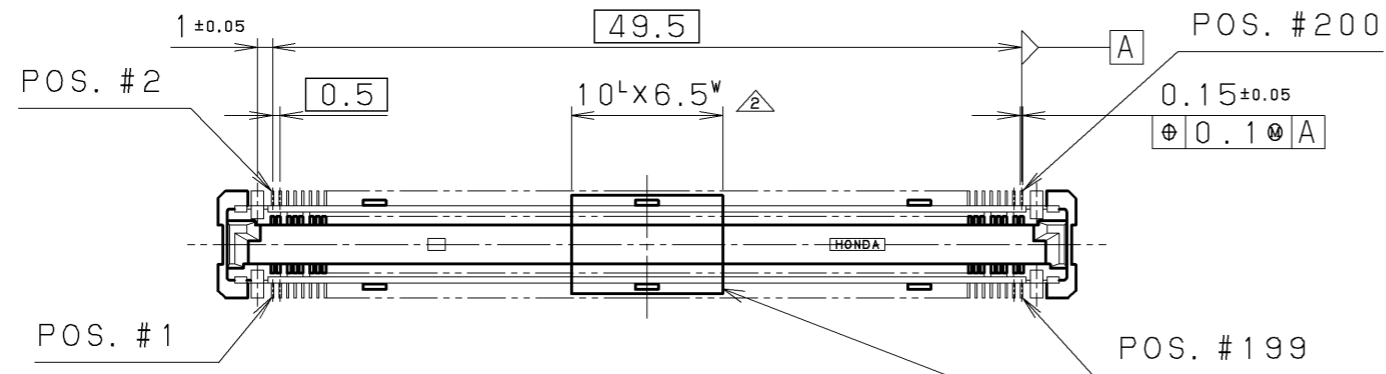

RECEPTACLE LPF-SC200SFYG (N) + MATED CONDITION (REF.) 嵌合状態図 (参考)

NOTE 1. COPLANALITY OF SMT TERMINAL IS 0.1 MAX.
 注1. SMT部のコプラナリティーは、0.1以下とする。
 NOTE 2. THIS SHOWS SURFACE DIMENSION OF SMT TERMINAL.
 注2. SMT面の寸法を示す。

4	耐热テープ	PI樹脂	1	
	HEAT-RESISTANT TAPE	PI RESIN		
3	シェル	ステンレス鋼	2	リフロー錫メッキ
	SHELL	STAINLESS		REFLOW TIN PLATING
2	絶縁体	LCP樹脂	1	UL94V-0 色:黒色
	INSULATOR	LCP RESIN		UL94V-0 COLOR:BLACK
1	コンタクト	銅合金	200	接触部:金メッキ 0.76µm以上
	CONTACT	COPPER ALLOY		SMT部:金フラッシュメッキ CONTACT AREA:GOLD 0.76µm MIN. TERMINAL AREA:GOLD FLASH

改版 LTR.	年月日 DATE	変更者 BY	変更内容 REV. DESCRIPT	番号 No.	部品名称 PART NAME	材質 MATERIAL	個数 QTY	処理 FINISH	備考 NOTE
	01.14 Jan.14 (2005)	S. Iijima	Add HEAT-RESISTANT TAPE						
		M. Miyazaki	Add Dim.						
年月日 DATE 尺度 SCALE 単位 UNIT 3角法 01.14 2/1 mm (INCH) 3RD. A. P Jan.14 (2005)					本多通信工業株式会社 HONDA TSUSHIN KOGYO CO., LTD.				
製 DR.	設 DE.	計 CHK.	検 CHK.	認 APP.	名 称 NAME	PLUG (200 POS. BOARD-TO-BOARD CONNECTOR, 0.5mm PITCH)			
M. MIYAZAKI	M. MIYAZAKI		C. NUNOKAWA	H. EBIHARA	製 番 PART NO.	LPF-SC200SMYGA+			
						REV.	2B		

APPLICABLE P. C. BOARD DIMENSION (REF.) 適合基板寸法図 (参考)

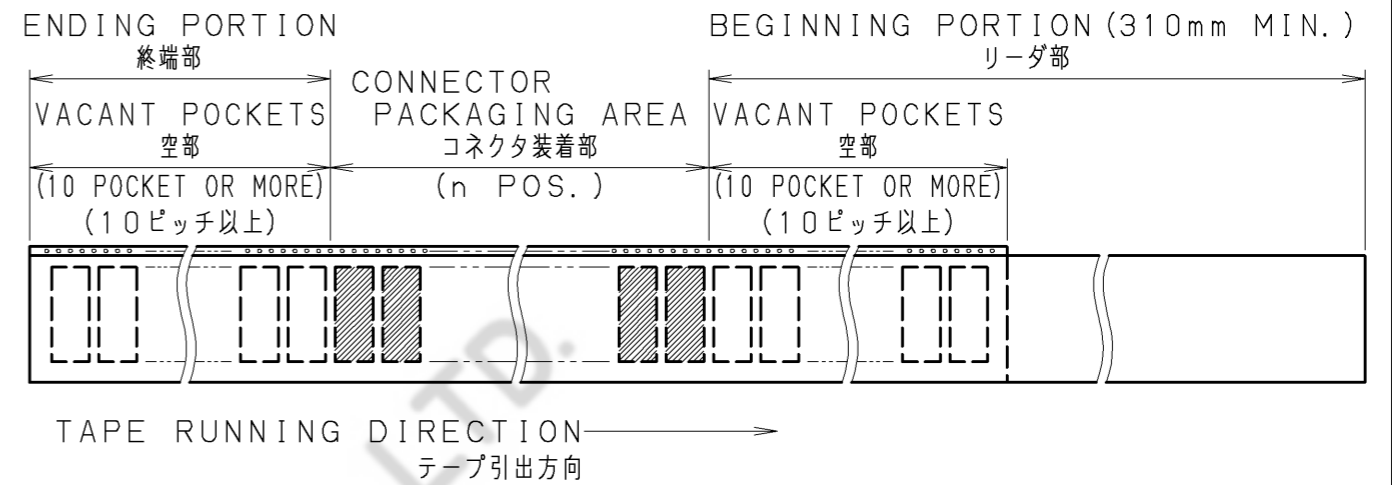
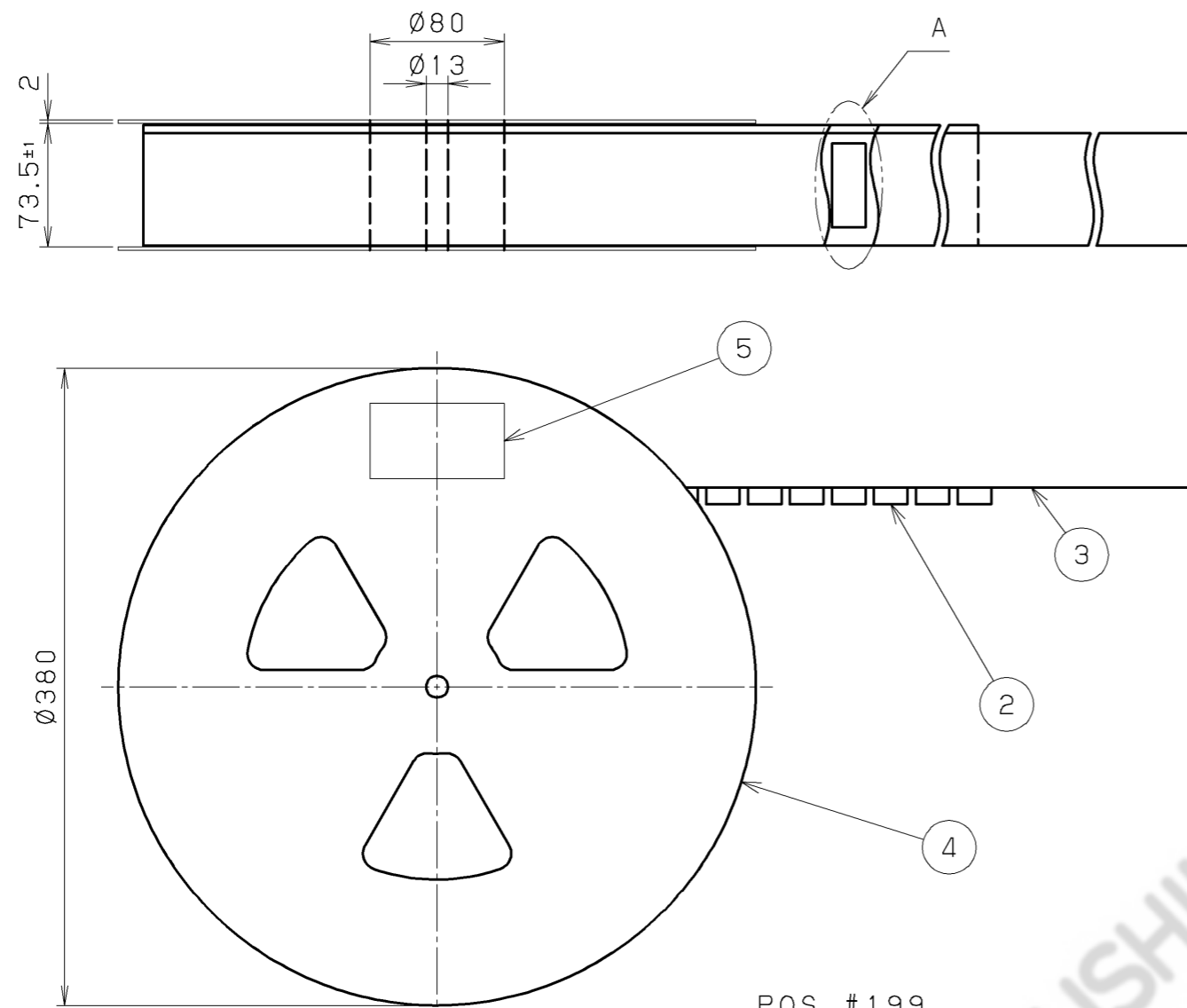
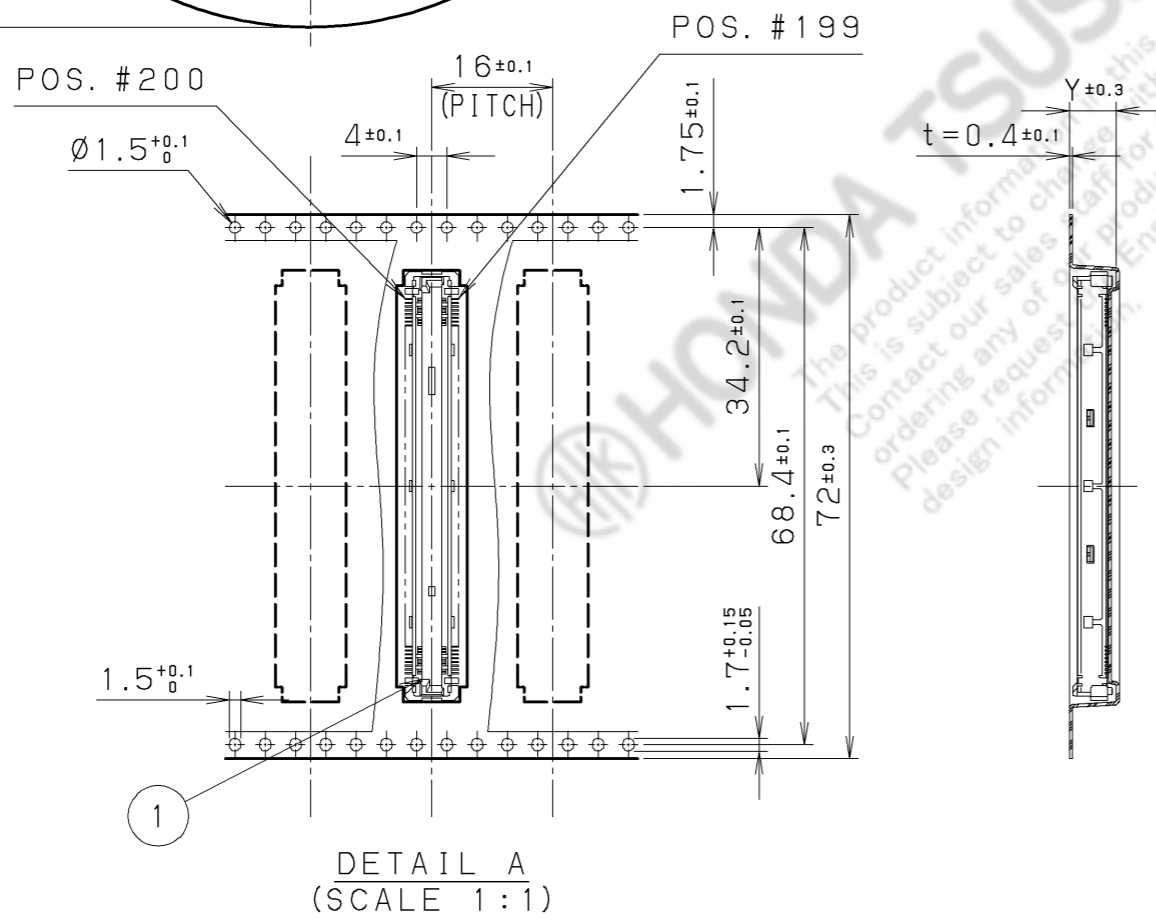
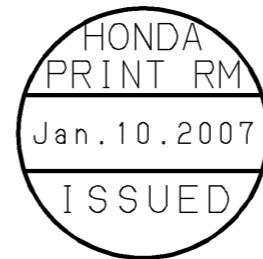

TABLE 1.
表1.

PART No. 製 番	PART No. OF CONNECTOR コネクタ製番	n	Y	HEAT-RESISTANT TAPE カプトンテープ
△ LPF-SC200SMYGN-TP+	LPF-SC200SMYGN+	800	6.2	THERE IS NOT.
△ LPF-SC200SMYGAN-TP+	LPF-SC200SMYGAN+	1000	5.2	THERE IS NOT.
△ LPF-SC200SMYG-TP+	LPF-SC200SMYG+	800	6.2	THERE IS. (10 ^t ×6.5 ^v)
△ LPF-SC200SMYGA-TP+	LPF-SC200SMYGA+	1000	5.2	THERE IS. (10 ^t ×6.5 ^v)
△ LPF-SC200SMY GK-TP+	LPF-SC200SMYG+	800	6.2	THERE IS. (20 ^t ×6.5 ^v)

NOTE 1. DIMENSIONS OF CONNECTORS ARE SHOWN IN THE INDIVIDUAL DRAWING.
注1. コネクタ寸法は別図面による。



5	ロット票 LOT LIST	紙 PAPER	1		
4	リール REEL	PS △ PS △	1		
3	カバーテープ COVER TAPING	PET PET	1		
2	エンボステープ EMBOSSED TAPING	PS PS	1		
1	コネクタ CONNECTOR		n		表1. 参照 SEE TABLE 1.

改版 LTR.	年月日 DATE	変更者 BY	変更内容 REV. DESCRIPT	番号 No.	部品名称 PART NAME	材質 MATERIAL	個数 QTY	処理 FINISH	備考 NOTE
	01.14 Jan. 14 (2005)	M. MIYAZAKI	Change material						
		M. MIYAZAKI	Add Part.						
		S. IJIMA	Change Part.						
		S. IJIMA	Revise						

年月日 DATE	尺度 SCALE	単位 UNIT	3角法 3RD. A. P	本多通信工業株式会社 HONDA TSUSHIN KOGYO CO., LTD.	
01.14 Jan. 14 (2005)	mm (INCH)	mm (INCH)	3RD. A. P	名称 NAME	CONNECTOR PACKAGING (EMBOSSED TAPING) コネクタ梱包図 (エンボステープ)
製 図 DR.	設 計 DE.	検 査 CHK.	検 査 CHK.	承認 APP.	製 番 PART NO.
M. MIYAZAKI	M. MIYAZAKI	S. IJIMA	C. NUNOKAWA	K. KASHIO	△ LPF-SC200SMYG (A) (N) (K) -TP+ REV. 4D