

5 GD!%)) &%'\$

F9J €€ B

RELEASE FOR PRODUCTION. ADD
 "HAPSTRAK" LOGO TO ITEM 1; NOTES
 CHG NOTES FROM "...GROUND PLANE
 RETENTION..." TO "...GROUND PLANE
 RETENTION..."; TOP VIEW. CHG 127 PIN
 NUMBER TO 128. CHG 128 PIN NUMBER TO
 127. ADD .005 DIM FRONT VIEW. DEL .268
 REF DIM. ADD .278 REF DIM. ADD .723 REF
 DIM. ADD .275 DIA REF. ADD .650 DIM. BOM
 ADD ITEM#

B	TP	M TOWNSEND
12/31/2007	ECN-84646	

BOM: CHG ITEM 2 FROM T-1S60-05-L
 TO ASP-137246-05-P-L & CHG ITEM 4
 FROM T-1G1-05-G TO ASP-137238-10-
 P-G

C	TT	T LOZIER
4/24/2008	ECN-89632	

BOM: CHG ITEM 2 FROM ASP-137246-
 05-P-L TO T-1S60-05-L. CHG ITEM 4
 FROM ASP-137238-10-P-G TO T-1G1-
 05-G

D	CP	T LOZIER
8/21/2008	ECN-96023	

BOM: CHG ITEM 4 FROM "T-1G1-05-G"
 TO "T-1G1-05-L"; PLATING SPECS:
 CHG: "000003 GOLD..." TO "000200
 MATTE TIN..."

E	FF	S MANGELS
9/23/2008	ECN-97757	

BOM: CHG K-500-300 TO K-DOT-276-
 375-.005

BC H9G

%*(DCGHCB'E H :GBC!G5B85F8"

&"I G95GD!%) (\$!\$' !6/ 5GD!%) (%)\$' !6'6C8-9G"

" "7) F9DF 9G9BHG5 '7F#7 5@8A 9BGC B"

("A B A I A 'DI G<C I H: C F 7 9.') @"

)"A B A I A : FCI B 8 D@B 9 F 9 H B H C B. %@6"

*"A 5 L A I A 'J 5 F -B 7 9 C : "\$S&O\$) Q5DD@9GHC 'G# B 5@CF; FCI B 8 G-B 8 9 D 9 B 8 9 B H

""C : 'H 9; FCI B 8 'C F 'G# B 5@D B G F 9 G D 9 7 H J 9 @M

+"; FCI B 8 'D@B 9 D F 9 G G < 9# < H A I G H 6 9 "\$\$ 'O\$+Q@GGH: 5 B 'H 9 A 5 L A I A < 9# < H

""C F "\$S&O\$ 'O: F 9 5 H F 'H: 5 B 'H 9 A B A I A < 9# < H C : 'G# B 5@D B"

;"D 5 F H G H C '6 9 D 5 7 ? 5; 9 8 'B 'H 5 M G"

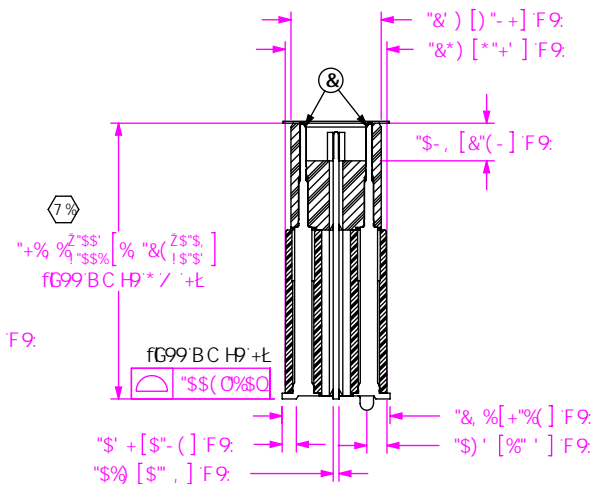
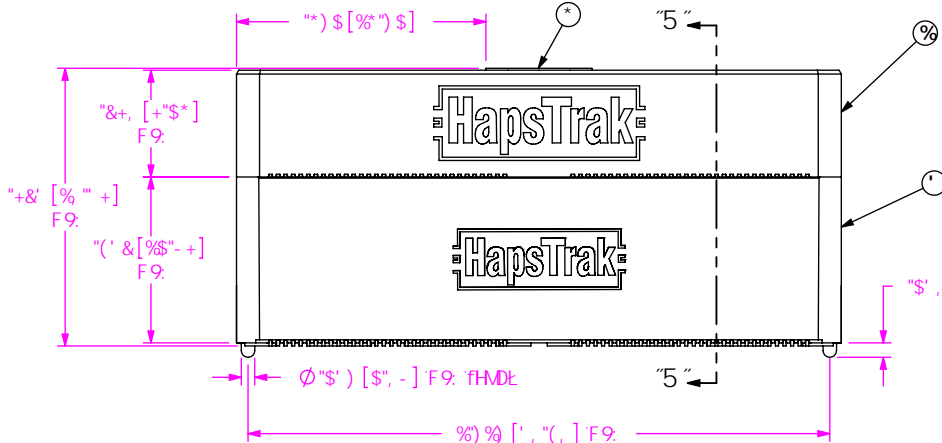
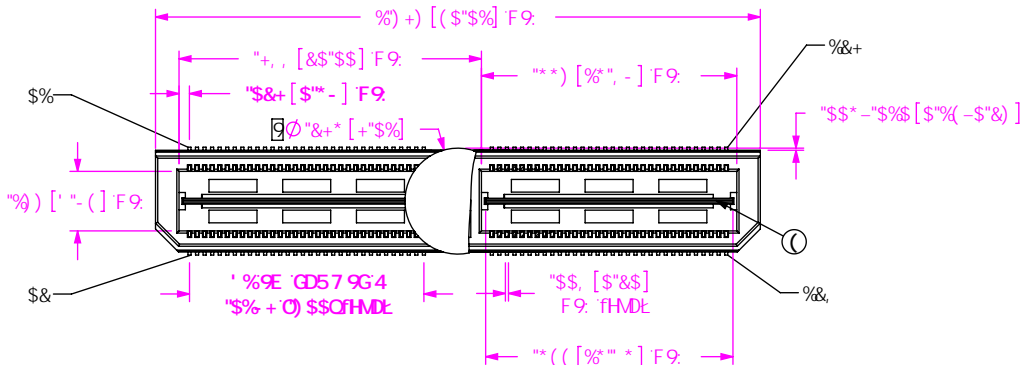
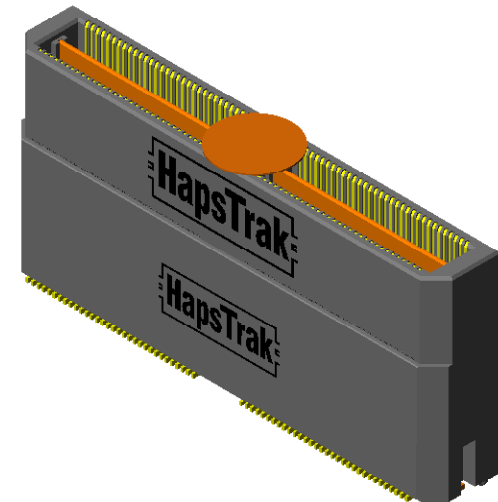

G97 HC B "5 '1 '5 "

85HR
 7 CA D5BM
 71 GCA 9# G# B5H F9
 DF B H 8 B 5 A 9
 D < C B 9 B C
 : 5 L B C

#DA BC "	D5FHBI A 69F	E I 5BH#M	A 5HF-5@
%	5GD!%) (\$!\$' !6	\$\$\$\$\$	J 97 HF 5 '9% \$j 7 C @C F. '6@7 ?
&	H%G \$!\$!)@	%&,"\$\$	D<C G 6 F C B N 9 z) %\$ GDF -B; 'H 9 A D 9 F
'	5GD!%) (%)\$' !6	\$\$\$\$\$	J 97 HF 5 '9% \$j 7 C @C F. '6@7 ?
(H% %\$!)@	&"\$\$\$\$	D<C G 6 F C B N 9 z) %\$ < 5 @ < 5 F 8 'H 9 A D 9 F
)	HF 5 ME LL \$\$&!DF!)\$ 15 DIH 5	\$\$\$\$\$	5 B H G H 5 H 7 '6@7 ? ' < @G
*	?!8CH"&*"! " +)! "\$\$)	\$(') \$\$	DC @VA -8 9: -@A

I B @GG C H: 9 F K '6 9 'GD 9 7 = 9 8 z	DFC DF -9 H 5 F M B C H 9
8 A 9 B G C B G 5 F 9 'B 'B 7 < 9 G"	H: 6 8 C 7 1 A 9 8 H 7 C B H 6 B G B: C F A 5 H C B
HC @F 5 B 7 9 G 5 F 9.	7 C B: 6 9 B H 5 @ 5 B 8 D F C D F @ 9 6 F M C
8 9 7 A 5 @G	G 5 A H 7 2 4 7 " 5 B 8 G: 5 @ 8 B C H 6 9 F 9 0 F C 8 1 7 9 8
"LL. ±\$%O' Q	C F H 5 B G 9 F 9 8 H C C H: 9 F B C 7 1 A 9 B H G C F
"LLL. ±\$%O' Q	8 4 7 @ 9 8 H C C H: 9 F G C F 1 0 9 8 : C F 5 B M
"LLLL. ±\$S&O\$) %Q	D I F D C 9 C H: 9 F H 5 B H 5 H K < 7 < H K 5 G
	C 6 4 5 4 9 8 K # C I H H: 9 9 L D F 9 0 9 8 K F H 9 8
	7 C B 0 9 8 H C: G 5 A H 7 2 4 7 "
8 C 'BCH G 7 5 @ 9 8 F 5 K B:	G: 9 9 H G 7 5 @ 9. & %
D@5 HB:	
H 9 A B 5 @/:	F C I B 8 D @ B 9.
7 C B H 5 7 H 5 F 9 5. "\$S&O\$) %Q	C @ 8 C J 9 F "\$S&O\$) \$ B 7 ? 9 @
F 9 A 5 B 8 9 F. "\$S&O\$) \$ A 5 H 9 H B C J 9 F "\$S&O\$) \$ B 7 ? 9 @	

samtec

) & \$ D 5 F ? ' 9 5 G H 6 @ 8 z B 9 K ' 5 @ 5 B M - B (+) \$
 D < C B 9 ; % & - ((! * + ' " ; : < = > ? @ A B C D E F G H I J K L M N O P Q R S T U V W X Y Z)) & %
 Y I A U J : ; < = > ? @ A B C D E F G H I J K L M N O P Q R S T U V W X Y Z)) & %

8 9 6 7 F D H C B.
 A C 8 @ 9 8 E H K ' 5 G G 9 A 6 @ M

8 K : " B C "

5 GD!%)) &%'\$

6 M 8 : F 5 @ 9 M \$ % # / 0 # & \$ + G < 9 9 H % C : &

:.PBK : PK P5 CDP%) \$\$\$P5 CDP%) 801\$ "G@B F K

