

REVISION

0	SS	D UNDERWOOD
10/11/2007 ECN-81424		
ISSUE FOR REVIEW		
1	RL	D Fletcher
5/13/2008 ECN-90758		
BOM CHG ITEMS FROM ASP-TRAY TO TY-ASP125.		
A	JB	D FRALEY
12/19/2008 ECN-102779		
RELEASE FOR PRODUCTION.		

NOTES:

1. CONTACT CONFIGURATION NOT AVAILABLE AS STANDARD.
2. Ⓢ REPRESENTS A CRITICAL DIMENSION.
3. MAXIMUM BURR ALLOWANCE: .038 [.0015].
4. MINIMUM PUSHOUT FORCE: 2.22N [.5 LB].
5. PARTS TO BE PACKAGED IN TRAYS.

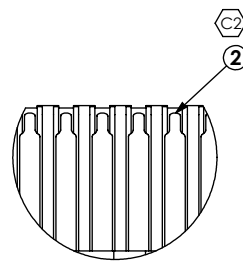
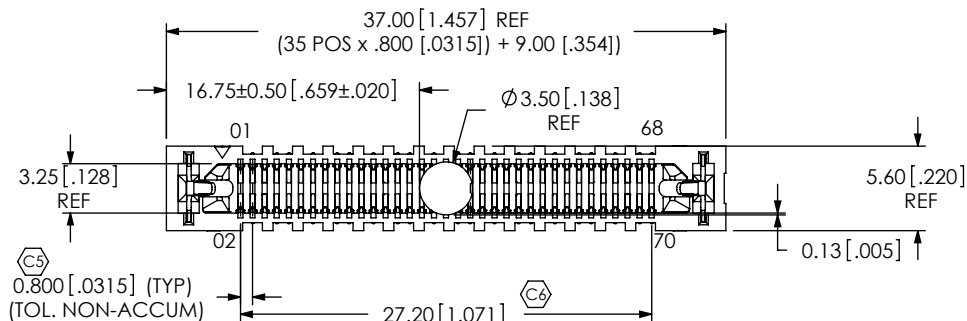

DETAIL 'B'
SCALE 6 : 1
SE SIDE

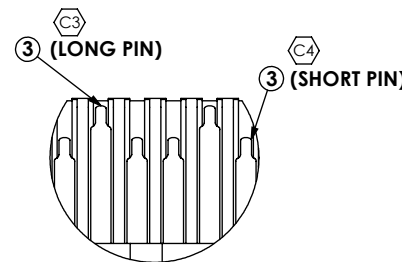

DETAIL 'D'
SCALE 6 : 1
DP SIDE

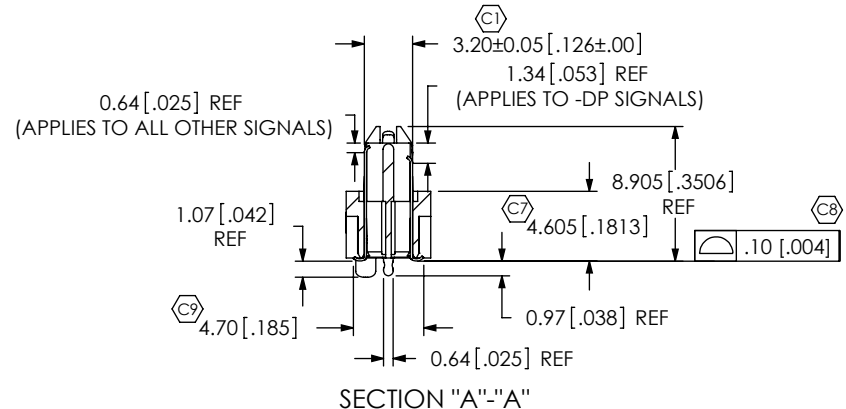
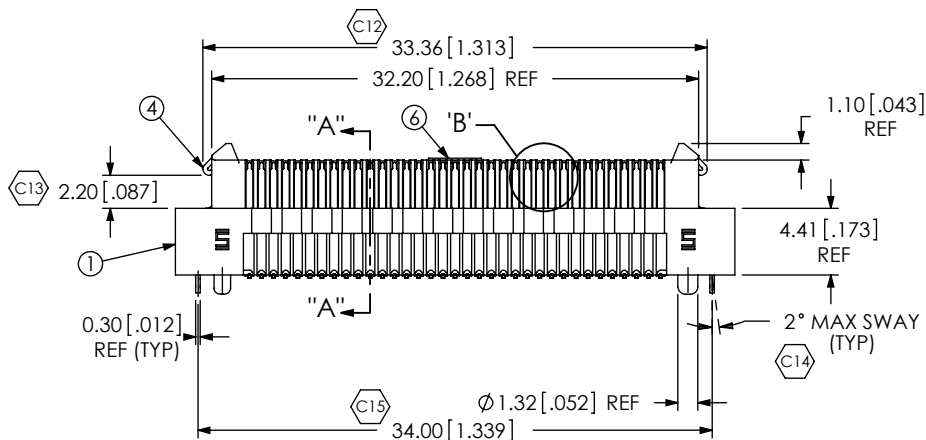

SECTION "A"- "A"

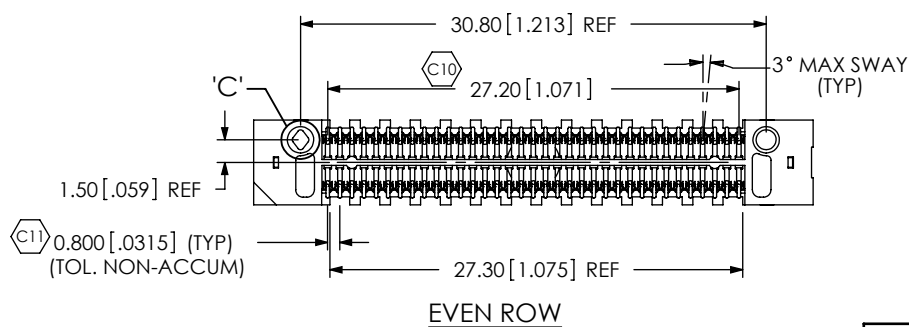

EVEN ROW

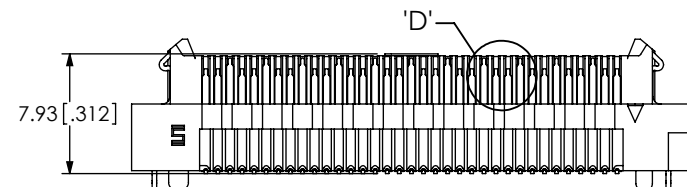

ODD ROW (DP SIDE, HOT PLUG SIDE)
(PIN ORIENTATION TO BE EXACTLY AS SHOWN)

ACCEPTANCE OF DRAWING
ACCEPTED WITH DEVIATIONS LISTED

DATE: _____
COMPANY: _____
CUSTOMER SIGNATURE _____
PRINTED NAME _____
PHONE NO: _____
FAX NO: _____

ITEM NO.	PART NUMBER	QUANTITY	MATERIAL
1	ERM8-035-05.0-DV-L	1.0000	VECTRA E130i, COLOR: BLACK
2	T-1M37-05.0-S	35.0000	PHOS BRONZE, 510 SPRING TEMPER
3	T-M48-05.0-S	35.0000	PHOS BRONZE, 510 SPRING TEMPER
4	WT-29-03-F	2.0000	BeCu #25, 1/2 HT
5	TY-ASP125	.01786	BLACK HIPS
6	K-500-300	1.0000	POLYIMIDE FILM (KAPTON)

UNLESS OTHERWISE SPECIFIED, DIMENSIONS ARE IN INCHES. TOLERANCES ARE: DECIMALS ANGLES .X: ±.3[.01] 2° .XX: ±.13[.005] .XXX: ±.051[.0020]	PROPRIETARY NOTE THIS DOCUMENT CONTAINS INFORMATION CONFIDENTIAL AND PROPRIETARY TO SAMTEC, INC. AND SHALL NOT BE REPRODUCED OR TRANSFERRED TO OTHER DOCUMENTS OR DISCLOSED TO OTHERS OR USED FOR ANY PURPOSE OTHER THAN THAT WHICH IT WAS OBTAINED WITHOUT THE EXPRESSED WRITTEN CONSENT OF SAMTEC, INC.	 520 PARK EAST BLVD., NEW ALBANY, IN 47150 PHONE: 812-944-6733 FAX: 812-948-5047 e-Mail: info@SAMTEC.com code: 55322
PLATING: CONTACT AREA: .000030 GOLD OVER .000050 NICKEL REMAINDER: .000200 REF TIN OVER .000050 NICKEL LATCHES: .000003 GOLD OVER .000050 NICKEL	DWG. NO. ASP-135020-01	BY: S. SELLE 10-11-2007 SHEET 1 OF 2

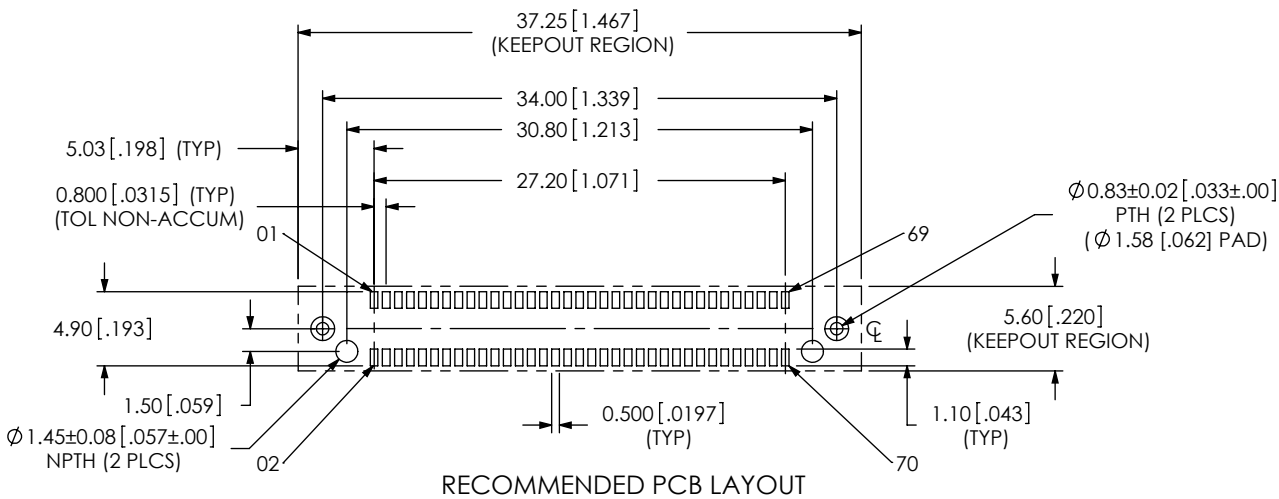

RECOMMENDED PCB LAYOUT

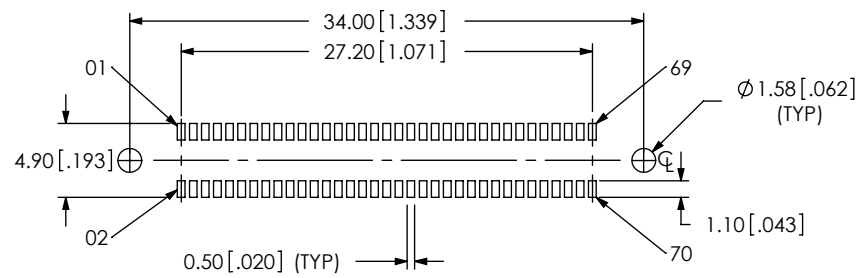

RECOMMENDED STENCIL LAYOUT

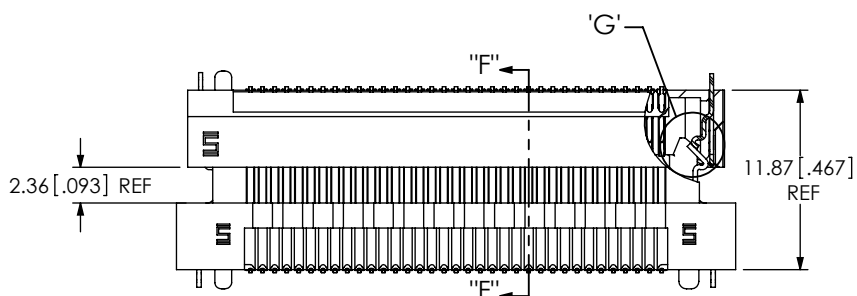

SECTION "F"-"F"

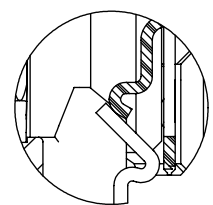

DETAIL 'G'
SCALE 6:1

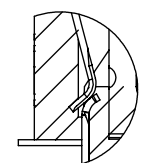

DETAIL 'H'
SCALE 6:1

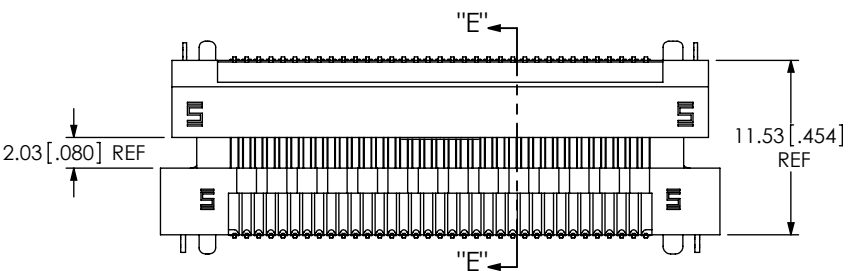

PIN ENGAGING VIEW

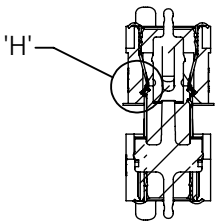

SECTION "E"-"E"

<p>PROPRIETARY NOTE THIS DOCUMENT CONTAINS INFORMATION CONFIDENTIAL AND PROPRIETARY TO SAMTEC, INC. AND SHALL NOT BE REPRODUCED OR TRANSFERRED TO OTHER DOCUMENTS OR DISCLOSED TO OTHERS OR USED FOR ANY PURPOSE OTHER THAN THAT WHICH IT WAS OBTAINED WITHOUT THE EXPRESSED WRITTEN CONSENT OF SAMTEC, INC.</p>	<p>samtec 520 PARK EAST BLVD, NEW ALBANY, IN 47150 PHONE: 812-944-6733 FAX: 812-948-5047 e-Mail: info@SAMTEC.com code: 55322</p>	
	<p>SHEET SCALE: 2:1</p>	<p>DESCRIPTION: MODIFIED ERM8 ASSEMBLY</p>
<p>DWG. NO. ASP-135020-01</p>		
<p>BY: S. SELLE 10-11-2007</p>		<p>SHEET 2 OF 2</p>