

Lubricator Made of Stainless Steel Throughout, up to 50 bar

L3000

Description	Lubricator for compressed air with bowl without sight glass, extremely robust, with manual adjustment of oil drip rate.
Bowl	stainless steel version without sight glass
Operating pressure	max. 50 bar
Temperature range	0 °C to 60 °C / 32 °F to 140 °F for NBR/Buna-N, for appropriately conditioned air down to -20 °C / -4 °F 0 °C to 130 °C / 32 °F to 266 °F for high temperature version
Material	Body: stainless steel 316L, material no. 1.4404 Bowl: stainless steel 316L, material no. 1.4404 Elastomer: NBR/Buna-N, optionally FKM Inner valve: stainless steel 316L, material no. 1.4404

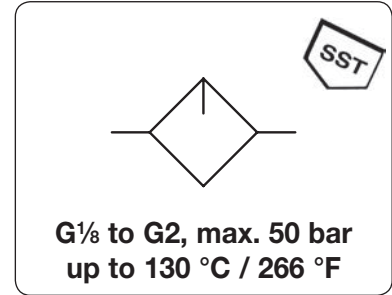

Dimensions			Bowl capacity l	Flow rate		Operating pressure max. bar	Connection thread G	Order number
A	B	C		m ³ /h*1	l/min*1			

Lubricator			operating pressure max. 50 bar				L3000		
40	124	80	0.04	45	750	50	G ¹ / ₈	L3000-01	
65	154	110	0.17	54	900	50	G ¹ / ₄	L3000-02	
				60	1000		G ³ / ₈	L3000-03	
80	167	121	0.28	144	2400	50	G ¹ / ₂	L3000-04	
				150	2500		G ³ / ₄	L3000-A6	
100	222	165	0.58	480	8000	50	G ³ / ₄	L3000-06	
				492	8200		G1	L3000-08	
200	268	201	1.00	720	12000	50	G1 ¹ / ₂	L3000-12	
				780	13000		G2	L3000-16	



Special options, add the appropriate letter

NPT	connection thread	L3000-..N
up to 130 °C / 266 °F	high temperature version	L3000-..X54
FKM elastomer		L3000-..V
flange connection	see end of the chapter / flanges	L3000-..F.

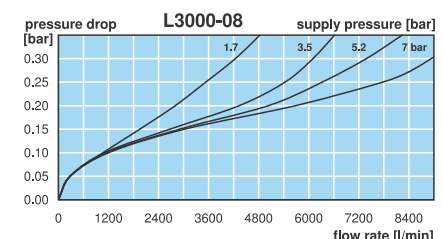
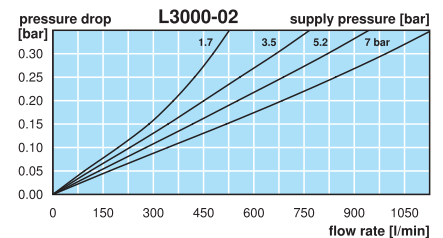
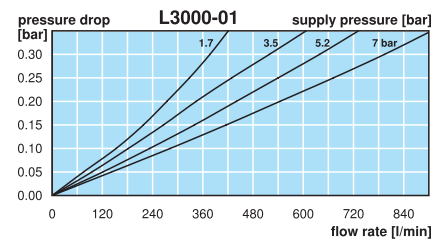
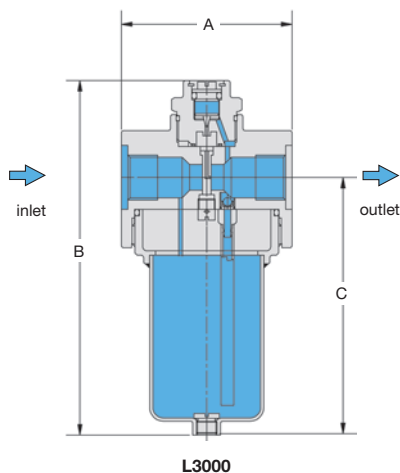

*1 at 7 bar operating pressure and 0.33 bar pressure drop



Order example:
L3000-01

China website: www.duray-control.cn

