

Sound and television broadcast receivers and associated equipment — Radio disturbance characteristics — Limits and methods of measurement

The European Standard EN 55013:2001, with the incorporation of amendment A1:2003, has the status of a British Standard

ICS 33.100.10

National foreword

This British Standard is the official English language version of EN 55013:2001, including amendment A1:2003. It was derived by CENELEC from CISPR 13:2001, including amendment 1:2003. It supersedes BS EN 55013:1997 which is withdrawn.

The start and finish of text introduced or altered by amendment is indicated in the text by tags **A1** **A1**. Tags indicating changes to CENELEC text carry the number of the CENELEC amendment. For example, text altered by CENELEC amendment A1 is indicated by **A1** **A1**.

The UK participation in its preparation was entrusted by Technical Committee GEL/210, Electromagnetic compatibility, to Subcommittee GEL/210/11, EMC Product standards, which has the responsibility to:

- aid enquirers to understand the text;
- present to the responsible European committee any enquiries on the interpretation, or proposals for change, and keep the UK interests informed;
- monitor related international and European developments and promulgate them in the UK.

A list of organizations represented on this subcommittee can be obtained on request to its secretary.

Cross-references

The British Standards which implement international publications referred to in this document may be found in the *BSI Catalogue* under the section entitled "International Standards Correspondence Index", or by using the "Search" facility of the *BSI Electronic Catalogue* or of British Standards Online.

This publication does not purport to include all the necessary provisions of a contract. Users are responsible for its correct application.

Compliance with a British Standard does not of itself confer immunity from legal obligations.

This British Standard, having been prepared under the direction of the Electrotechnical Sector Policy and Strategy Committee, was published under the authority of the Standards Policy and Strategy Committee on 03 December 2001

Summary of pages

This document comprises a front cover, an inside front cover, the EN title page, pages 2 to 44, an inside back cover and a back cover.

The BSI copyright notice displayed in this document indicates when the document was last issued.

Amendments issued since publication

Amd. No.	Date	Comments
13656 Incorp. Corrigendum No. 1	15 January 2002	Correction to Table 5 and copyrights
14680	30 September 2003	See national foreword

English version

**Sound and television broadcast receivers
and associated equipment -
Radio disturbance characteristics -
Limits and methods of measurement
(including amendment A1:2003)
(CISPR 13:2001 + A1:2003, modified)**

Récepteurs de radiodiffusion et de
télévision et équipements associés -
Caractéristiques des perturbations
radioélectriques -
Limites et méthodes de mesure
(inclut l'amendement A1:2003)
(CISPR 13:2001 + A1:2003, modifiée)

Ton- und Fernseh-Rundfunkempfänger
und verwandte Geräte der
Unterhaltungselektronik -
Funkstöreigenschaften -
Grenzwerte und Messverfahren
(enthält Änderung A1:2003)
(CISPR 13:2001 + A1:2003, modifiziert)

This European Standard was approved by CENELEC on 2001-09-01; amendment A1 was approved by CENELEC on 2003-04-01. CENELEC members are bound to comply with the CEN/CENELEC Internal Regulations which stipulate the conditions for giving this European Standard the status of a national standard without any alteration.

Up-to-date lists and bibliographical references concerning such national standards may be obtained on application to the Central Secretariat or to any CENELEC member.

This European Standard exists in three official versions (English, French, German). A version in any other language made by translation under the responsibility of a CENELEC member into its own language and notified to the Central Secretariat has the same status as the official versions.

CENELEC members are the national electrotechnical committees of Austria, Belgium, Czech Republic, Denmark, Finland, France, Germany, Greece, Hungary, Iceland, Ireland, Italy, Luxembourg, Malta, Netherlands, Norway, Portugal, Slovakia, Spain, Sweden, Switzerland and United Kingdom.

CENELEC

European Committee for Electrotechnical Standardization
Comité Européen de Normalisation Electrotechnique
Europäisches Komitee für Elektrotechnische Normung

Central Secretariat: rue de Stassart 35, B - 1050 Brussels

Foreword

The text of document CISPR/E/213/FDIS, future edition 4 of CISPR 13, prepared by CISPR SC E, Interference relating to radio receivers, was submitted to the IEC-CENELEC parallel vote. Together with a common modification prepared by SC 210A, EMC Products, of Technical Committee CENELEC TC 210, Electromagnetic compatibility (EMC), it was approved by CENELEC as EN 55013 on 2001-09-01.

This European Standard supersedes EN 55013:1990 + A12:1994 + A13:1996 + A14:1999.

The following dates were fixed:

- latest date by which the EN has to be implemented at national level by publication of an identical national standard or by endorsement (dop) 2002-06-01
- latest date by which the national standards conflicting with the EN have to be withdrawn (dow) 2004-09-01

Annexes designated "normative" are part of the body of the standard.
In this standard, annex ZA is normative.
Annex ZA has been added by CENELEC.

Endorsement notice

The text of the International Standard CISPR 13:2001 was approved by CENELEC as a European Standard with agreed common modifications.

Foreword to amendment A1

The text of document CISPR/I/58/FDIS, future amendment 1 to CISPR 13:2001, prepared by CISPR SC I, Electromagnetic compatibility of information technology equipment, multimedia equipment and receivers, was submitted to the IEC-CENELEC parallel vote and was approved by CENELEC as amendment A1 to EN 55013:2001 on 2003-04-01.

The following dates were fixed:

- latest date by which the amendment has to be implemented at national level by publication of an identical national standard or by endorsement (dop) 2004-01-01
- latest date by which the national standards conflicting with the amendment have to be withdrawn (dow) 2006-04-01

Annexes designated "normative" are part of the body of the standard.
Annexes designated "informative" are given for information only.
In this standard, annex A is normative and annex B is informative.

Endorsement notice

The text of amendment 1:2003 to the International Standard CISPR 13:2001 was approved by CENELEC as an amendment to the European Standard without any modification.

CONTENTS

INTRODUCTION.....	6
1 Scope and object.....	7
2 Normative references.....	7
3 Definitions and abbreviations	8
3.1 Definitions	8
3.2 Abbreviations.....	9
4 Limits of disturbance.....	9
4.1 General	9
4.2 Disturbance voltage at the mains terminals	10
4.3 Disturbance voltage at the antenna terminals	10
4.4 Wanted signal and disturbance voltage at the RF output of equipment with incorporated or with add-on RF video modulator.....	11
4.5 Disturbance power.....	12
4.6 Radiated disturbances	12
4.7 Radiated power	13
5 Measurement procedures	13
5.1 General	13
5.2 Test signals.....	13
5.3 Disturbance voltage at the mains terminals in the frequency range 150 kHz to 30 MHz	14
5.3.1 General	14
5.3.2 Television receivers	15
5.3.3 Sound receivers.....	16
5.3.4 Associated equipment.....	16
5.3.5 Audio amplifiers	16
5.3.6 Measurement of the disturbance voltage at the mains terminals	17
5.4 Measurement of disturbance voltage at the antenna terminals of a receiver and associated equipment with an RF input in the frequency range 30 MHz to 2,15 GHz	17
5.4.1 General	17
5.4.2 Measurement on receivers or associated equipment with coaxial antenna connections.....	17
5.4.3 Measurement on receivers or associated equipment with balanced antenna connectors	18
5.4.4 Presentation of the results	18

5.5	Measurement of the wanted signal and disturbance voltage at the RF output terminals of associated equipment with an RF video modulator, in the frequency range 30 MHz to 2,15 GHz.....	18
5.5.1	Introduction	18
5.5.2	Method of measurement	18
5.6	Measurement of disturbance power of associated equipment (video recorders excluded) in the frequency range 30 MHz to 1 GHz	19
5.6.1	General	19
5.6.2	Method of measurement	19
5.6.3	Measuring procedure	19
5.6.4	Presentation of the results	20
5.7	Measurement of radiation in the frequency range 30 MHz to 1 GHz at 3 m distance.....	20
5.7.1	Introduction	20
5.7.2	Measuring site requirements	21
5.7.3	Disposition of the receiver under test	22
5.7.4	Disposition of the field-strength meter	22
5.7.5	Measurement procedure	23
5.8	Measurement of radiation in the frequency range 1 GHz to 18 GHz	23
5.8.1	Measuring set-up	23
5.8.2	Test site validation	24
5.8.3	Measuring procedure	24
5.8.4	Presentation of the results	25
5.9	Measurement of the local oscillator power at the input terminal of the outdoor unit	25
6	Interpretation of CISPR radio disturbance limits	25
6.1	Significance of a CISPR limit	25
6.2	Compliance with limits on a statistical basis	26
	Annex A (normative) Broadcast receivers for digital signals	33
	Annex B (informative) Specification of the wanted signal	38
	Annex ZA (normative) Normative references to international publications with their corresponding European publications	43
	Bibliography.....	44
	Figure 1 – Colour bar signal levels according to ITU-R Recommendation BT 471-1 (see 5.2) (“red” signal)	27
	Figure 2 – Teletext picture (see 5.2).....	27
	Figure 3 – Example of an artificial mains network 50 Ω-50 μH (see 5.3.1).....	28
	Figure 4 – Example of artificial mains network 50 Ω-50 μH-5 Ω (see 5.3.1).....	28
	Figure 5 – Measurement of the radiofrequency disturbance voltage injected into the mains (see 5.3.1).....	29
	Figure 6 – Measurement of the radiofrequency disturbance voltage injected into the mains (top view) (see 5.3.1).....	29
	Figure 7 – Circuit arrangement for the measurement of disturbance voltages at the coaxial antenna terminals (see 5.4.2).....	30

Figure 8 – Circuit arrangement for receivers with balanced antenna connections (see 5.4.3)	30
Figure 9 – Circuit arrangement for the measurement of the wanted signal and disturbance voltage at the RF output of video recorders (see 5.5.2)	30
Figure 10 – Circuit arrangement for the measurement of disturbance power of associated equipment (video recorders excluded) (see 5.6.3)	31
Figure 11 – Measuring site (see 5.7.2).....	31
Figure 12 – Check of the site suitability (see 5.7.2).....	31
Figure 13 – Theoretical site attenuation curve for the range 80 MHz to 1 GHz (see 5.7.2)	32
Figure 14 – Open-field measurement at 3 m distance (see 5.7.3).....	32
Figure A.1 – Measurement of the radiofrequency disturbance voltage injected into the mains (see 5.1.3 and 5.1.4) in the frequency range 150 kHz to 30 MHz (side view)	36
Figure A.2 – Example of isolation transformer for 46 MHz to 1,5 GHz	36
Figure A.3 – Typical size of isolation transformer for 46 MHz to 1,5 GHz.....	37
Figure A.4 – Typical characteristic of insertion loss of isolation transformer for 46 MHz to 1,5 GHz	37

INTRODUCTION

The CISPR recommends that the limits and methods of measurement of radio disturbance characteristics of sound and television receivers contained in the latest edition of CISPR 13, including amendments, be used, without regional or national addenda or modifications. The requirements are considered sufficient to reach adequate emission levels to protect radio broadcast and telecommunication services and to allow other apparatus to operate as intended at a reasonable distance.

SOUND AND TELEVISION BROADCAST RECEIVERS AND ASSOCIATED EQUIPMENT – RADIO DISTURBANCE CHARACTERISTICS – LIMITS AND METHODS OF MEASUREMENT

1 Scope and object

This International Standard applies to the generation of electromagnetic energy from sound and television receivers for the reception of broadcast and similar transmissions and from associated equipment. The frequency range covered extends from 9 kHz to 400 GHz.

No measurements need be performed at frequencies where no limits are specified.

Receiving systems for collective reception, in particular:

- cable distribution head ends (Community Antenna Television, CATV);
- community reception systems (Master Antenna Television, MATV)

are covered by IEC 60728-2.

Ⓐ) Broadcast receivers for digital signals are covered by Annex A and Annex B. Ⓐ)

Information technology equipment (ITE) is excluded, even if intended to be connected to a television broadcast receiver.

The telecommunication port of broadcast receivers, intended to be connected to a telecommunication network, is covered by CISPR 22.

In addition, measurements at the telecommunication port are performed with the broadcast reception functions, which are independent from the telecommunication function, disabled during the measurement.

PC tuner cards are measured according to the relevant clauses of this standard.

This standard describes the methods of measurement applicable to sound and television receivers or associated equipment and specifies limits for the control of disturbance from such equipment.

For multifunction equipment which is subjected simultaneously to different clauses of this standard and/or other standards, details are given in 4.1.

2 Normative references

The following normative documents contain provisions which, through reference in this text, constitute provisions of this International Standard. For dated references, subsequent amendments to, or revisions of, any of these publications do not apply. However, parties to agreements based on this International Standard are encouraged to investigate the possibility of applying the most recent editions of the normative documents indicated below. For undated references, the latest edition of the normative document referred to applies. Members of IEC and ISO maintain registers of currently valid International Standards.

CISPR 16-1, *Specification for radio disturbance and immunity measuring apparatus and methods – Part 1: Radio disturbance and immunity measuring apparatus*

CISPR 16-2, *Specification for radio disturbance and immunity measuring apparatus and methods – Part 2: Methods of measurement of disturbances and immunity*

CISPR 22, *Information technology equipment – Radio disturbance characteristics – Limits and methods of measurement*

IEC 60050(161), *International Electrotechnical Vocabulary (IEV) – Chapter 161: Electromagnetic compatibility*

IEC 60728-2, *Cabled distribution systems for television and sound signals – Part 2: Electromagnetic compatibility for equipment*¹

ITU-R BT 471-1, *Nomenclature and description of colour bar signals*

3 Definitions and abbreviations

3.1 Definitions

For the purposes of this International Standard, the definitions contained in IEC 60050(161) and the following definitions apply.

3.1.1

sound broadcast receivers

appliances intended for the reception of sound broadcast and similar services for terrestrial, cable and satellite transmission, regardless whether the input signals are digital or analog

3.1.2

television receivers

appliances intended for the reception of television broadcast and similar services for terrestrial, cable and satellite transmissions, regardless whether the input signals are digital or analog

3.1.3

associated equipment

equipment either intended to be connected directly to sound or television broadcast receivers, or to generate or reproduce audio or visual information

NOTE 1 Tuners may be provided with a broadcast-satellite-receiving stage and with demodulators, decoders, demultiplexers, D/A converters, encoders (e.g. NTSC, PAL or SECAM encoders), etc.

NOTE 2 Frequency converters may be provided with a broadcast-satellite-receiving stage and with devices which convert the signals to other frequency bands.

NOTE 3 Receivers, tuners, or frequency converters may be tuneable or may only be able to receive a fixed frequency.

¹ To be published.

3.1.4

PC tuner cards

sound broadcast receiver cards and television broadcast receiver cards, either to be inserted in personal computers or permanently integrated therein

3.1.5

outdoor unit of direct to home satellite receiving systems for individual reception

unit consisting of the antenna, the feeding network and the low-noise amplifier with its associated down-converter. The intermediate frequency amplifier and the demodulator are not included

3.1.6

multifunction equipment

appliances in which two or more functions are provided in the same unit, for instance television reception, radio reception, digital clock, tape-recorder or disc player, etc.

3.2 Abbreviations

AM	Amplitude Modulation
CATV	Community Antenna Television
CD	Compact Disc
FM	Frequency Modulation
ITE	Information Technology Equipment
ITU-R	International Telecommunication Union – Radio
LW, MW and SW	Long-, Medium- and Short-Waves
MATV	Master Antenna Television
PC	Personal Computer
RF	Radio Frequency

4 Limits of disturbance

4.1 General

For RF disturbances the level shall not exceed the limits specified in 4.2 to 4.7 when measured using the methods given in clause 5. Where there is frequency duplication at the boundary of two ranges, the lower limit shall apply. For equipment in large-scale production, it is required that, with 80 % confidence, at least 80 % of production complies with the limits (see clause 6).

Multifunction equipment which is subjected simultaneously to different clauses of this standard and/or other standards shall be tested with each function operated in isolation, if this can be achieved without modifying the equipment internally. The equipment thus tested shall be deemed to have complied with the requirements of all clauses/standards when each function has satisfied the requirements of the relevant clause/standard.

For equipment for which it is not practical to test with each function operated in isolation, or where the isolation of a particular function would result in the equipment being unable to fulfil its primary function, the equipment shall be deemed to have complied if it meets the provisions of the relevant clause/standard with the necessary functions operative.

4.2 Disturbance voltage at the mains terminals

Measurements shall be made in accordance with 5.3.

Table 1 – Limits of disturbance voltage at the mains terminals

Equipment type	Frequency range MHz	Limit values dB(μV)	
		Quasi-peak	Average
Television and sound receivers and associated equipment	0,15 to 0,5	66 to 56 ^a	56 to 46 ^a
	0,5 to 5	56	46
	5 to 30	60	50
^a Decreasing linearly with the logarithm of the frequency.			

NOTE 1 If the limits for the average detector are met when using the quasi-peak detector, then the limits for the measurements with the average detector are considered to be met.

NOTE 2 The higher value measured with and without the outer conductor screen of the antenna terminal connected to earth is considered.

NOTE 3 Television receivers with teletext facilities should be tested in teletext mode with teletext picture.

4.3 Disturbance voltage at the antenna terminals

Measurements of the antenna terminal voltage shall be made in accordance with 5.4.

The limit values specified correspond to a nominal impedance of 75 Ω.

The limit values for receivers with nominal impedance other than 75 Ω are calculated according to the following formula:

$$L_Z = L_{75} + 10 \log (Z/75) \text{ dB}(\mu\text{V})$$

Table 2 – Limits of disturbance voltage at the antenna terminals

Equipment type	Source	Frequency MHz	Limit values dB(μ V) 75 Ω Quasi-peak ^a
Television receivers, video recorders and PC tuner cards working in channels between 30 MHz and 1 GHz	Local oscillator	$\leq 1\ 000$	Fundamental 46
		30 to 950	Harmonics 46
		950 to 2 150	Harmonics 54
	Other	30 to 2 150	46
Television receivers for broadcast satellite transmissions and tuner units ^b	Local oscillator	950 to 2 150	Fundamental 54
		950 to 2 150	Harmonics 54
	Other	30 to 2 150	46
Frequency modulation sound receivers and PC tuner cards	Local oscillator	$\leq 1\ 000$	Fundamental 54
		30 to 300	Harmonics 50
		300 to 1 000	Harmonics 52
	Other	30 to 1 000	46
Frequency modulation car radios	Local oscillator	$\leq 1\ 000$	Fundamental 66
		30 to 300	Harmonics 59
		300 to 1 000	Harmonics 52
	Other	30 to 1 000	46
Associated equipment with an RF input, e.g. video tape player, laser disc player	Other	30 to 2 150	46
^a At frequencies above 1 GHz the peak detector is used.			
^b For tuner units, "antenna terminal" means "first intermediate frequency input terminal".			

NOTE For AM broadcast receivers for LW, MW and SW no limits apply.

4.4 Wanted signal and disturbance voltage at the RF output of equipment with incorporated or with add-on RF video modulator

Measurements of the wanted signal and disturbance voltage at the RF output terminals of equipment with incorporated or with add-on RF video modulator (e.g. of video recorders and decoders) shall be made in accordance with 5.5. If the nominal impedance of the RF output is different from 75 Ω , the limit level shall be calculated with the formula given in 4.3.

Table 3 – Limits of the wanted signal and disturbance voltage at RF output terminals of equipment with RF video modulator

Equipment type	Source	Frequency MHz	Limit values dB(μ V) 75 Ω Quasi-peak ^a
Equipment with RF video modulator (e.g. video recorders, camcorders and decoders)	Wanted signal		Carrier frequencies and sidebands 76
		30 to 950	Harmonics 46
		950 to 2 150	Harmonics 54
	Other	30 to 2 150	46
^a At frequencies above 1 GHz the peak detector is used.			

4.5 Disturbance power

Measurements shall be made in accordance with 5.6.

Table 4 – Limits of disturbance power

Equipment type	Frequency MHz	Limit values dB(pW)	
		Quasi-peak	Average
Associated equipment (video recorders excluded)	30 to 300	45 to 55 ^a	35 to 45 ^a
^a Increasing linearly with the frequency.			

NOTE If the limits for the average detector are met when using the quasi-peak detector, the limits for the measurements with average detector are considered to be met.

4.6 Radiated disturbances

Measurements of the disturbance field due to the local oscillator at its fundamental and harmonic frequencies and due to all other sources shall be made in accordance with 5.7.

Table 5 – Limits of radiated disturbances at 3 m distance

Equipment type	Source	Frequency MHz	Limit values dB(μV/m) Quasi-peak
Ⓢ Television receivers, video recorders and PC tuner cards	Local oscillator	≤1 000	Fundamental 57 ^a
		30 to 300	Harmonics 52
	Other	300 to 1 000	Harmonics 56
		30 to 230	40
		230 to 1 000	47
Television and sound receivers for broadcast satellite transmissions (except outdoor units), Infrared remote control units and Infrared headphone systems	Other	30 to 230	40
		230 to 1 000	47
Frequency modulation sound receivers and PC tuner cards	Local oscillator	≤1 000	Fundamental 60
		30 to 300	Harmonics 52
	Other	300 to 1 000	Harmonics 56
		30 to 230	40
		230 to 1 000	47
^a In Japan: 57 dB(μV/m) is relaxed to 66 dB(μV/m) for operating channels <300 MHz and to 70 dB(μV/m) for operating channels >300 MHz.			
Ⓢ			

NOTE For car radio receivers and for LW, MW and SW AM broadcast receivers no radiation limits apply.

4.7 Radiated power

Measurement of the radiated power due to the local oscillator at its fundamental and harmonic frequencies and due to all other sources shall be made in accordance with 5.8.

Table 6 – Limits of radiated power of tuner units of direct to home satellite receivers

Equipment type	Source	Frequency GHz	Limit values dB(pW)
Television and sound receivers for broadcast satellite transmissions: tuner units	Local oscillator	1 to 3	Fundamental 57
		1 to 3	Harmonics 57

Table 7 – Limits of radiated power of outdoor units of direct to home satellite receivers

Equipment type	Source	Frequency GHz	Limit value dB(pW)
Outdoor units of direct to home satellite receivers	Local oscillator leakage radiated from the antenna within $\pm 7^\circ$ of the main beam axis ^a	0,9 to 18	Fundamental 30
		1 to 2,5 2,5 to 18	43 57

^a The direct measurement is carried out according to 5.9. When the reflector of the parabolic antenna cannot be removed, the indirect measurement according to 5.8 is carried out. In that case, the antenna gain shall be taken into account.

^b Measurement of the equivalent radiated power shall be in accordance with 5.8. No requirements within $\pm 7^\circ$ off the main beam axis of the antenna.

5 Measurement procedures

5.1 General

This clause deals with standardized measurement procedures and measuring equipment.

Deviations from this standard are allowed (e.g. the use of broad-band antennas, the dimensions of the screened room) provided that the measurement results are comparable to those resulting from the standardized method and the deviations are noted in the test report.

In case of controversy, the procedure as formulated in this standard shall take precedence.

5.2 Test signals

The standard test signal for television receivers and for other equipment with video signal input/output and/or an RF modulator is a standard television colour bar signal according to ITU-R BT 471-1 (see figure 1). The modulation of the video and the audio signals on the RF carrier shall be according to the system for which the equipment is intended.

In the case of television receivers, the wanted signal shall be a vision carrier modulated by a complete video waveform including a colour burst together with an unmodulated sound carrier of the correct relative amplitude and frequency.

The teletext picture shall preferably be the one shown in figure 2, consisting of rows of numbers completely filling the screen. If this picture is not available, measurement shall be done with the main index page of the national teletext broadcast service. In the latter case the picture used shall be indicated with the results.

NOTE For countries using non-alphabetical systems, the test pattern of the national teletext broadcast service also can be used.

The standard test signals for radio receivers are:

- a) Band II: an RF signal frequency modulated with a monophonic signal at 1 kHz with 37,5 kHz deviation;
- b) LW/MW/SW: an RF signal amplitude modulated with a signal at 1 kHz with 50 % modulation.

The standard test signals for associated equipment are:

- a) audio amplifiers and infrared headphones: a sinusoidal signal at 1 kHz;
- b) associated audio equipment e.g. audio tape recorders, record players, CD players: a tape or disc recorded 1 kHz audio signal with a standard sound level specified by the manufacturer of the equipment under test;
- c) associated video equipment, e.g. video tape players, camcorders, laser disc players: a tape or disc recorded standard television colour bar signal with 1 kHz audio signal, with a standard sound level specified by the manufacturer of the equipment under test;
- d) electronic organs: a signal derived from depressing the upper C note (approx. 523 Hz);
- e) infrared remote controls: a permanent transmission of a typical control function.

For equipment for which the wanted signals are not explicitly described in this standard, the nominal signals as specified by the manufacturer shall be applied during the tests. (This is e.g. the case for broadcast receivers for digital signals, decoders, etc.) The manufacturer shall specify in his technical report which input signal was applied during the tests.

An infrared remote control is considered as a part of the main unit and tested together. Remote controls marketed separately are only tested on radiated disturbances (table 5).

5.3 Disturbance voltage at the mains terminals in the frequency range 150 kHz to 30 MHz

5.3.1 General

The measured voltage includes narrow-band interference from the time-base, video circuits and broad-band interference such as that produced by semiconductor rectifiers.

An artificial mains V-network is required to provide defined impedances at high frequencies between the mains terminals of the equipment under test and reference earth. The network also provides a suitable filter to isolate the equipment under test circuit from unwanted RF voltages that may be present on the supply mains.

An artificial mains network according to CISPR 16-1 shall be used which is suitable for measuring the disturbance voltage between each mains terminal of the equipment under test and the reference earth in the frequency range 0,15 MHz to 30 MHz (see also figures 3 and 4).

Disturbance voltage measurements should be carried out in a screened room as depicted in figures 5 and 6.

NOTE Floor-standing equipment should be placed directly on the floor. If the cabinet of the equipment under test is of conducting material and not provided with insulating legs or wheels, the points of contact should be separated from the metallic ground-plane by insulating material of up to 12 mm thickness.

5.3.2 Television receivers

The television receiver shall be tuned to a standard test signal as defined in 5.2. A small pick-up antenna (see figures 5 and 6) is connected to the receiver for this purpose. If the receiver is provided with a built-in antenna, this one shall be used (the pick-up antenna shall be disconnected).

In case of monitor TV, a video signal generator producing the standard television signal as defined in 5.2 shall be connected to the video input connector of the monitor via an isolation transformer.

NOTE The isolation may be provided by an isolation transformer with common impedance to earth of 75Ω for the frequency range 0,15 MHz to 30 MHz. Alternatively, the video signal could be applied in series with toroidal RF chokes (one in each conductor) of $60 \mu\text{H}$ impedance, connected by very short leads to the video input connector.

The input signal shall be sufficiently strong to give a noise-free picture.

The controls of the equipment under test for contrast, brightness and colour saturation, shall be set to produce a normal picture.

This is obtained with the following luminance values:

- black part of the test pattern: 2 cd/m^2 ;
- magenta part of the test pattern: 30 cd/m^2 ;
- white part of the test pattern: 80 cd/m^2 .

NOTE The luminance of the magenta part of the test pattern should be set to 30 cd/m^2 . If this level cannot be reached, the luminance should be set to the maximum possible. If a value different from 30 cd/m^2 is used, it should be stated together with the results.

Television receivers with teletext facilities shall be tested in teletext mode with a teletext picture.

5.3.3 Sound receivers

The standard test signals for sound receivers shall be according to 5.2.

For AM sound receivers provided with ferrite antennas or rod antennas, the radiating antenna of figures 5 and 6 shall be replaced by a radiating loop or radiating rod antenna.

The volume control of the receiver under test shall be adjusted to be 1/8 of the rated audio output power. The other controls shall be in their middle or neutral operating positions. The output terminals shall be terminated with resistive loads equal to the rated load impedances.

In case the rated load impedance has a certain range, a value of the rated load for which the equipment under test attains maximum power shall be used.

Sound AM/FM receivers shall be tested in FM operating mode.

5.3.4 Associated equipment

The standard test signals for associated equipment are defined in 5.2.

Associated equipment with RF input can be measured as a television or sound receiver, as appropriate.

Modular units which perform a part of the functions unique to a sound or television receiver (like tuners, frequency converters, RF amplifiers, RF equalizers, monitors, etc.) are measured similarly to sound or television receivers respectively.

Remote controls of receivers and associated equipment are considered to be part of the main unit.

5.3.5 Audio amplifiers

An audio frequency signal generator shall be connected to an input terminal of the equipment under test via an isolation transformer.

NOTE The isolation may be provided by an isolation transformer with a common mode impedance to earth of at least 500 Ω for the frequency range 0,15 MHz to 30 MHz. Alternatively the audio signal could be applied in series with toroidal RF chokes (one in each conductor) of 60 μH inductance, connected by very short leads to the audio input connectors.

The amplifier output terminals shall be terminated with a resistive load equal to the rated load impedance.

In case the rated load impedance has a certain range, a value of the rated load for which the equipment under test attains maximum power shall be used.

The level of the audio output signal shall be adjusted by the volume control to be 1/8 of the rated output power for each output.

The setting of the other controls shall be in middle or neutral position.

5.3.6 Measurement of the disturbance voltage at the mains terminals

The receiver or associated equipment under measurement and the artificial mains network are disposed as shown in figures 5 and 6. The artificial mains network shall be as indicated in 5.3.1. Measurements shall be carried out using a selective voltmeter having a quasi-peak detector for broadband measurements and an average detector for narrow-band measurements in accordance with CISPR 16-1.

The mains lead shall be arranged to follow the shortest possible path between the receiver and artificial mains network on the ground. The mains lead in excess of 0,8 m separating the equipment under test from the artificial mains network shall be folded back and forth parallel to the lead so as to form a bundle with a length of 0,3 m to 0,4 m.

Earthing of the equipment under test if provided with a safety earth connection, shall be made to the earth terminal provided on the artificial mains network with the shortest possible lead.

If the equipment under test has a coaxial RF input connector, tests shall be performed with and without an earth connection made to the outer conductor screen of the coaxial RF input connector. When these tests are being carried out, no other earth connections shall be made to any additional earth terminal whatever.

If the equipment under test has no coaxial RF input connector and if it has an earth terminal, tests shall be performed with this terminal earthed.

5.4 Measurement of disturbance voltage at the antenna terminals of a receiver and associated equipment with an RF input in the frequency range 30 MHz to 2,15 GHz

5.4.1 General

When measurements are made at the antenna terminal of the equipment under test, an auxiliary signal generator shall be used to feed the receiver input with an RF signal at the receiver or associated equipment tuning frequency (see 5.2).

The output level of the auxiliary signal generator shall be set to give at the antenna input terminal of the receiver the value of 60 dB(μ V) for frequency modulation receivers and 70 dB(μ V) for television receivers, on 75 Ω impedance.

In the case of frequency-modulation receivers, the auxiliary signal shall be an unmodulated carrier.

5.4.2 Measurement on receivers or associated equipment with coaxial antenna connections

The antenna terminals of the receiver or associated equipment and the auxiliary signal generator are connected to the measuring set by means of coaxial cables and a resistive combining network having a minimum attenuation of 6 dB (see figure 7).

The impedance as seen from the receiver or associated equipment shall be equal to the nominal antenna input impedance for which the receiver has been designed.

The equipment under test shall be tuned to the wanted signal.

The measuring set is tuned to the relevant radiated frequency and the disturbance level is measured taking into account the attenuation between the receiver antenna terminal and the measuring set input.

NOTE 1 Radiofrequency currents flowing from the chassis of the receiver to the outer surface of the screening of the coaxial cables should be prevented from penetrating into the coaxial system and thus causing erroneous measuring results, for example by means of ferrite tubes.

NOTE 2 Attention should be given to possible overloading of the input stage of the measuring set due to the output signal of the auxiliary generator.

5.4.3 Measurement on receivers or associated equipment with balanced antenna connectors

The method of measurement is similar to that described in 5.4.2. The measuring set-up is given in figure 8.

A matching network shall, if necessary, be inserted between the receiver or associated equipment and the selective voltmeter at a distance of 0,50 m from the receiver, and connected to the receiver by means of an unscreened balanced feeder, to give correct matching between the receiver and the balanced-to-unbalanced transformer, which attenuates the asymmetric currents. If the asymmetric currents are troublesome, as can generally be verified by reversing the connections of the balanced feeder at the antenna terminals of the receiver, they shall be suppressed by suitable devices, e.g. ferrite tubes or stop filters.

NOTE No details of the matching networks and of the balanced-to-unbalanced transformer are given, because different techniques are possible, for example a transmission line wound on a magnetic core or ferrite suppression rings.

5.4.4 Presentation of the results

The results shall be expressed in terms of the disturbance voltage in dB(μ V). The specified input impedance of the receiver or associated equipment shall be stated with the results.

5.5 Measurement of the wanted signal and disturbance voltage at the RF output terminals of associated equipment with an RF video modulator, in the frequency range 30 MHz to 2,15 GHz

5.5.1 Introduction

If equipment with RF output (e.g. video recorders, camcorders, decoders) is intended to be connected to the antenna terminals of a television receiver, additional measurements of the wanted signal level and disturbance voltage at its RF output terminals shall be performed. The reason is that a too high level of the RF output signal or its harmonics can be radiated from the combination causing interference in the neighbourhood.

5.5.2 Method of measurement

The RF output of the equipment under test is connected to the input of the measuring set by means of a coaxial cable and a matching network (if necessary) as shown in figure 9. The characteristic impedance of the cable shall be equal to the nominal output impedance of the equipment under test.

The equipment under test shall produce an RF carrier modulated by a vertical colour bar video signal (see figure 1).

The RF output level can be obtained by adding the insertion loss of the matching network to the indication of the measuring set (tuned on the video carrier frequency and its harmonics) or of a spectrum analyser.

5.6 Measurement of disturbance power of associated equipment (video recorders excluded) in the frequency range 30 MHz to 1 GHz

5.6.1 General

It is generally considered that for frequencies above 30 MHz the disturbing energy produced by an appliance is propagated by radiation to the disturbed receiver.

Experience has shown that the disturbing energy is mostly radiated by the portions of the mains lead and other connected leads near the appliance. It is therefore agreed to define the disturbing level of an appliance as the power it could supply to its mains lead and other connected leads.

This power is nearly equal to that supplied by the appliance to a suitable absorbing clamp placed around any of these leads at the position where the absorbed power is at its maximum.

5.6.2 Method of measurement

The described method is applicable for measurement of disturbance power, expressed in terms of available power, produced at the terminals of the associated equipment in the range 30 MHz to 1 GHz.

The standard test signal and operating conditions of the associated equipment under test are given in 5.2. The method of measurement, the measuring set-up and the absorbing clamp shall be in accordance with CISPR 16.

5.6.3 Measuring procedure

The associated equipment under test is placed on a non-metallic table of 0,8 m of height above the floor and at least 0,8 m from other metallic objects and from any person. The lead to be measured shall be stretched in a straight horizontal line for a length sufficient to accommodate the absorbing clamp and to permit the necessary adjustment of its position for tuning. The absorbing clamp is placed around the lead to be measured, with its current transformer towards the equipment under test, so as to measure a quantity proportional to the disturbance power on the lead (see figure 10).

Any other lead than that to be measured shall either be disconnected, if mechanically and functionally possible, or fitted with ferrite rings to attenuate RF currents which may affect the measurement results. Such a lead shall be stretched away from the connected unit in a direction perpendicular to the direction of the lead to be measured.

All connectors not used shall be left unterminated. All connectors having a connected lead shall be terminated in a manner representative of use. If the leads are screened and normally terminated in a screened unit, then the termination shall be screened.

The absorbing clamp is applied successively to all leads whose length is 25 cm or longer, unscreened or screened, which may be connected to the individual units of the equipment under test (e.g. the lead to the mains or to the power supply, signal leads, control leads, etc.).

On interconnecting leads between units, belonging to the same equipment under test, two measurements shall be made, the current transformer of the absorbing clamp facing the first unit, at one end of the lead, then facing the second unit at the other end of the same lead.

At each test frequency the absorbing clamp shall be moved along the lead until the maximum value is found between a position adjacent to the equipment under test and a distance of about a half wavelength from it. If necessary, the connected leads shall be extended to have a length of a half wavelength at 30 MHz (i.e. 5 m) plus twice the length of the absorbing clamp.

However, on an interconnecting lead of original length shorter than a half wavelength at the lower frequencies, which at its end is connected to a unit having no other external lead, the movement of the absorbing clamp from this same unit is further restricted to a distance equal to the original length of the lead.

NOTE An initial measurement could be made with the absorbing clamp in a fixed position to find frequencies where the disturbance might be particularly strong.

5.6.4 Presentation of the results

The measured power is expressed in dB(pW) and derived from the maximum indicated value and the calibration curve of the absorbing clamp (see also the example given in annex H of CISPR 16-1).

The disturbance power level is given by the highest of the maximum values noted at each frequency of measurement on the mains lead or other connected leads.

5.7 Measurement of radiation in the frequency range 30 MHz to 1 GHz at 3 m distance

5.7.1 Introduction

The method described here is applicable for the measurement of radiation, expressed in terms of electric field strength, from frequency modulation receivers, television receivers, video recorders, etc. (see table 5). This method of measurement should be used outdoors or indoors with special arrangements.

Measurements with the method here described may also be made in a large indoor room with anechoic treatment or on outdoor sites protected from the weather by suitable non-metallic coverings, for example radomes or pressurized plastic domes, provided these sites comply with 5.7.2.

Outdoor weather-protected measuring sites should not be used during rain or snow until it has been verified by a site attenuation test that the radiofrequency measuring conditions do not change appreciably during such weather conditions.

NOTE The effect of atmospheric pollution on the radiofrequency characteristics of a site covered by a plastic dome should be ascertained by attenuation tests repeated at appropriate intervals.

Measurements may alternatively be carried out using the measurement methods as described in CISPR 22 or CISPR 16-1.

5.7.2 Measuring site requirements

The measuring site shall be flat and free of reflecting objects. No extraneous metallic objects, having any dimension in excess of 50 mm shall be in the vicinity of the receiver or associated equipment under test or of the field-strength meter aerial. The receiver and the field-strength meter antenna shall be located over a metallic ground screen having the dimensions 6 m × 9 m, as shown in figure 11.

Where the ground screen deviates from an ideal conducting plane or where the measuring site is enclosed, it should be established that significant variations of the results are not introduced.

The horizontal distance between the field-strength meter antenna and the dipole connected to the generator or the centre of the receiver or associated equipment shall be 3 m (see figures 12 and 14).

For the frequency range 80 MHz to 1 GHz, the suitability of the site and of the measuring equipment shall be checked by using the arrangement shown in figure 12. The receiver shall be replaced by a standard signal generator. A tuned horizontal transmitting dipole shall be connected to this generator output by a well-screened transmission line correctly terminated at both ends. The height of the transmitting dipole shall be 4 m. Starting at 4 m, the field-strength meter antenna shall be adjusted in height to measure the first maximum that occurs at or below 4 m.

The site attenuation A is expressed, in dB, as:

$$A = P_t - P_r$$

where

P_t is the power supplied to the tuned transmitting dipole, in dB(pW);

P_r is the available power at the tuned receiving dipole terminals, in dB(pW).

NOTE 1 When the signal generator, the field-strength meter and the transmission lines have the same impedance, the site attenuation can be measured as:

$$A = |V_a - V_b| - a_t - a_r \quad (\text{dB})$$

where

$|V_a - V_b|$ is the absolute value in dB of the difference between the input levels of the field-strength meter for a convenient generator output level V_g (or the difference between the output levels of the signal generator for a convenient reading V_r on the field-strength meter) noted in the following measurements, when:

- a) the two transmission lines are connected to the transmitting and receiving antenna respectively;
- b) the two transmission lines are disconnected from the antennas and connected together;

a_t and a_r are the attenuation in dB at the measuring frequency of the balun and any matching pad at the transmitting and receiving side respectively, included in measurement a) and excluded in measurement b).

For a satisfactory site, the measured attenuation shall not deviate by more than ± 3 dB from the theoretical curve shown in figure 13.

NOTE 2 At high sensitivity, errors may result from mismatch at the input terminals of the field-strength meter, internally generated noise or extraneous signals. The radiated power should be sufficiently high to use the field-strength meter on a sensitivity range for which an error in the reading does not exceed $\pm 1,5$ dB.

5.7.3 Disposition of the receiver under test

The receiver under test shall be placed on a support of non-metallic material, the height of which shall be 0,8 m above the ground, as shown in figure 14. The equipment under test shall be rotatable in a horizontal plane.

The centre of the measuring antenna and the centre of the receiver under test shall be in the same vertical plane.

The mains cable shall be placed in the same plane, as shown in figure 14, with the excess length folded back and forth parallel to the lead so as to form a horizontal bundle with a length between 0,3 m and 0,4 m at the mains-plug end.

Adequate filtering shall be incorporated in the mains supply, so that the accuracy of the measurement is not affected.

A suitable test signal (see 5.2) is supplied by a signal generator placed at the ground plane underneath the receiver under test, and connected to it via the shortest possible vertical cable.

The signal generator shall be coupled to the receiver under test by a coaxial cable of good quality. The screen of the cable shall be earthed at ground level (see figure 14).

For receivers with a built-in antenna and no external antenna terminal, the built-in antenna shall be used and the test signal (see 5.2) obtained from a vertical transmitting antenna connected to the signal generator. This antenna shall not be closer than 3 m from the receiver under test antenna and at least 6 m from the field-strength meter antenna, measured as horizontal distance.

Telescopic antennas shall be pulled out to their maximum lengths and fixed in a vertical position if there is a single rod, and in a position 45° from the vertical, forming an approximate V, if there are two rods.

NOTE The radiation may be measured without a test signal applied to the antenna input of the receiver under test. In this case, the antenna terminals of the receiver should be terminated with a non-inductive resistor of a value equal to the characteristic impedance for which the receiver has been designed.

In the case of PC tuner cards, separately marketed for incorporation in diverse host units (e.g. PCs) the card shall be tested in at least one appropriate representative host unit of the choice of the manufacturer.

Measurements are carried out with the tuner card inserted in a personal computer, switched on and the antenna input connector terminated with a non-radiating dummy load.

5.7.4 Disposition of the field-strength meter

5.7.4.1 Antenna of the field-strength meter

This antenna shall be a dipole rotatable in a vertical plane perpendicular to the axis of the measuring site (see figure 11) and the height of the centre shall be capable of variation over a range from 1 m to 4 m (see figure 14).

Between 80 MHz and 1 GHz, the field-strength measurement shall be made with a dipole $\lambda/2$ long at the measuring frequency.

Between 30 MHz and 80 MHz, the field-strength measurement shall be made with a dipole having a constant length corresponding to $\lambda/2$ at 80 MHz. Over this range of 30 MHz to 80 MHz, the field-strength meter shall be calibrated with this fixed dipole by means of a reference field, the calibration being made at the height above earth of 4 m.

5.7.4.2 Feeder

A suitable feeder shall be mounted as indicated in figure 14 with a distance between the dipole and the vertical part of the feeder of more than 1 m.

5.7.4.3 Field-strength meter

A suitable field-strength meter shall be placed at a convenient height.

5.7.5 Measurement procedure

Starting with the front of the receiver under test facing the measuring antenna, the measuring antenna is adjusted for horizontal polarization measurement and its height varied between 1 m and 4 m until the maximum reading is obtained.

The receiver under test is then rotated about its centre until the maximum meter reading is obtained, after which the measuring antenna height is again varied between 1 m and 4 m and the maximum reading noted.

The procedure is repeated for vertical polarization of the measuring antenna, the height being varied from 2 m to 4 m in this case.

The highest value found, following this procedure, is defined as the radiation figure of the receiver.

If at certain frequencies the ambient signal fieldstrength is high at the position of the receiving antenna, one of the following methods may be used to show compliance of the equipment under test.

- a) For small frequency bands with high ambient signals, the disturbance value may be interpolated from the adjacent values. The interpolated value shall lie on the curve describing a continuous function of the disturbance values adjacent to the ambient noise.
- b) Another possibility is to use the method described in annex C of CISPR 11.

5.8 Measurement of radiation in the frequency range 1 GHz to 18 GHz

5.8.1 Measuring set-up

The equipment under test shall be placed on a turntable of non-metallic material, the height of which shall be 1 m above the ground.

Equipment which needs an input signal shall be connected to a suitable signal generator through a "well-screened" cable.

NOTE A cable can be considered "well-screened" if its radiation level, when terminated with a matched load, is at least 10 dB below the expected radiation level of the equipment under test, the cable and the equipment being supplied with the same input signal level.

The unused output terminals, if any, of the equipment under test shall be terminated with their nominal impedance by means of non-radiating loads.

The mains lead, if any, shall be placed vertically and connected to the mains outlet through a suitable mains filter. Any excess length of the mains lead shall be made into a neat vertical bundle with a length between 0,3 m and 0,4 m.

The mains lead and the signal generator coaxial cable shall be provided with suitable absorbing devices (e.g. ferrite rings), placed close to the equipment under test, to avoid measurement errors.

The measurements shall be made with a directive antenna of small aperture capable of making separate measurements of the vertical and horizontal components of the radiated field. The height above the ground of the centre line of the antenna shall be the same as the height of the radiation centre of the equipment under test.

In order to avoid the influence of the ground reflection on the results, it is recommended to use a suitable horn antenna. In that case no metallic ground plane is needed. To fulfil the "Fraunhofer conditions" the measuring distance d shall be:

$$d \geq 2 b^2/\lambda$$

where

b is the wider dimension of the horn aperture;

λ is the wavelength corresponding to the test frequency.

For large ratios of measuring distance d to measuring height ($h = 1$ m) the ground plane may have to be covered with a non-reflecting material to be able to fulfil the site validation criterion stated in 5.8.2.

The measuring set used in this frequency range usually consists of a spectrum analyzer. In the case that the radiation level is low, a low-noise preamplifier could be needed.

5.8.2 Test site validation

The validation of the site shall be determined as follows. A transmitting antenna shall be mounted at the position where it is intended that the approximate radiation centre (usually the volume centre) of the equipment under test is to be placed. The transmitting antenna shall have the same radiation properties as a half-wave dipole. The receiving antenna shall be placed at the same position as that chosen for the actual measurements. The two antennas shall be placed so that they have the same polarization which shall be perpendicular to an imaginary line between them. Tests shall be made in the horizontal and vertical polarization planes.

The site shall be considered suitable for the purpose of measurement at a test frequency if the indication on the measuring set changes by no more than $\pm 1,5$ dB when the centre of the transmitting antenna is moved from 0 cm to 15 cm in any direction from its initial position.

NOTE For measurements between 1 GHz and 4 GHz, either a half-wave dipole or a horn antenna may be used as a transmitting antenna. For measurements above 4 GHz a horn antenna should be used. When a horn antenna is used, its gain above the half-wave dipole should be taken into account.

5.8.3 Measuring procedure

Measurements shall be made by the substitution method with the antenna having both horizontal and vertical polarizations, and the turntable with the equipment under test shall be rotated. The highest level of radiation measured shall be noted at each measuring frequency.

The equipment under test is then replaced by a transmitting antenna supplied by a standard generator and having the same characteristics as the receiving antenna (half-wave dipole or horn antenna). Its centre shall be placed in the same initial position as that of the equipment centre.

For each measuring frequency the output level of the generator is adjusted in order to give the same reference indication on the measuring set. The level of the available power of the generator, increased by the radiating antenna gain above the half-wave dipole, is taken as the level of the radiated power of the equipment under test at the considered frequency.

It shall be ascertained that, when the equipment under test is switched off, the level of background noise is at least 10 dB below the relevant limit, otherwise the reading may be significantly affected.

When a horn antenna is used instead of a dipole antenna, the measurement results shall be expressed in terms of ERP referred to a half-wave dipole.

5.8.4 Presentation of the results

The radiation level of the equipment under test shall be expressed in terms of substituted equivalent power in dB(pW).

5.9 Measurement of the local oscillator power at the input terminal of the outdoor unit

If a suitable interface at the input of the outdoor unit (e.g. R120, C120) is available, the local oscillator power can be measured directly by a power meter or spectrum analyzer combined with a corresponding adapter as an alternative to the measurement of the radiation. Due allowance shall be made for the feed losses between the available interface and the antenna flange.

6 Interpretation of CISPR radio disturbance limits

6.1 Significance of a CISPR limit

A CISPR limit is a limit which is recommended to national authorities for incorporation in national standards, relevant legal regulations and official specifications. It is also recommended that international organizations use these limits.

The significance of the limits for type-approved appliances shall be that on a statistical basis, at least 80 % of the mass-produced appliances comply with the limits with 80 % confidence level.

Type tests can be made:

- a) on a sample of appliances of the type with statistical evaluation in accordance with 6.2, or
- b) for simplicity, on one item only.

Subsequent tests on items taken at random from the production are necessary from time to time, especially in the case of b) above.

In the case of controversy involving the possible withdrawal of a type approval, withdrawal shall be considered only after tests on an adequate sample in accordance with a) above.

6.2 Compliance with limits on a statistical basis

The test, based on the non-central t -distribution, should be performed on a sample of not less than five items of the type, but if in exceptional circumstances five items are not available, then a sample of three shall be used.

Compliance is judged from the following relationship:

$$\bar{x}_n + ks_n \leq L$$

where

s_n is the standard deviation of n items in the sample, according to

$$s_n^2 = \frac{1}{n-1} \sum (x_i - \bar{x}_n)^2$$

where

\bar{x}_n is the arithmetic mean value of the levels of n items in the sample;

x_i is the level of an individual item;

k is the factor derived from tables of the non-central t -distribution with 80 % confidence that 80 % of the type is below the limit; the value of k depends on the sample size n and is stated below;

L is the permissible limit.

The quantities x , \bar{x}_n , s_n and L are expressed logarithmically, namely in dB(μ V), dB(μ V/m) or dB(pW).

n	3	4	5	6	7	8	9	10	11	12
k	2,04	1,69	1,52	1,42	1,35	1,30	1,27	1,24	1,21	1,20

Should the test on the sample result in non-compliance with the requirements of 6.2, then a second sample may be tested and the results combined with those from the first sample and compliance checked for the larger sample.

NOTE For general information, see CISPR 16-3.

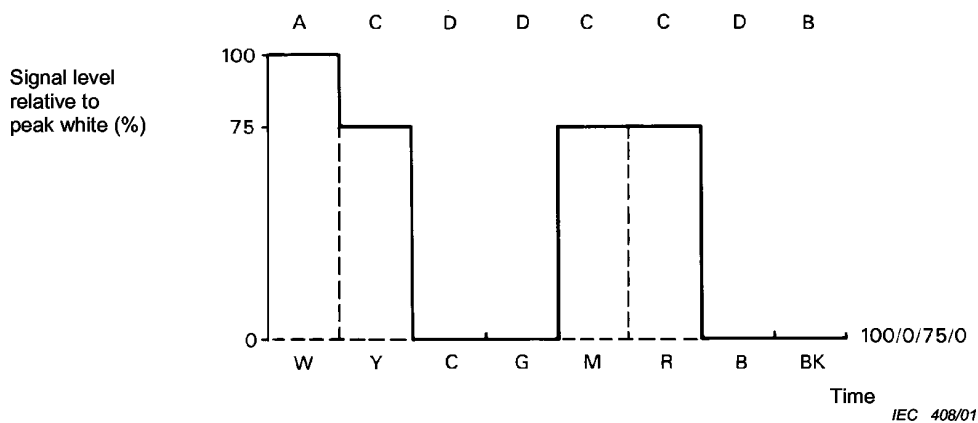

W	white
Y	yellow
C	cyan
G	green
M	magenta
R	red
B	blue
BK	black

A: the primary colour signal level during the transmission of the "white" colour bar;
 B: the primary colour signal level during the transmission of the "black" colour bar;
 C: the maximum of the primary colour signal during transmission of the "coloured" colour bars;
 D: the minimum level of the primary colour signal during transmission of the "coloured" colour bars.

Figure 1 – Colour bar signal levels according to ITU-R Recommendation BT 471-1 (see 5.2) ("red" signal)

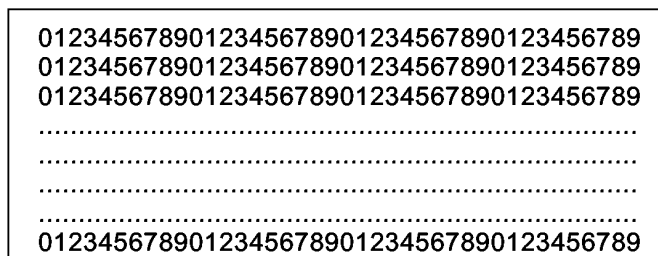

IEC 409/01

Figure 2 – Teletext picture (see 5.2)

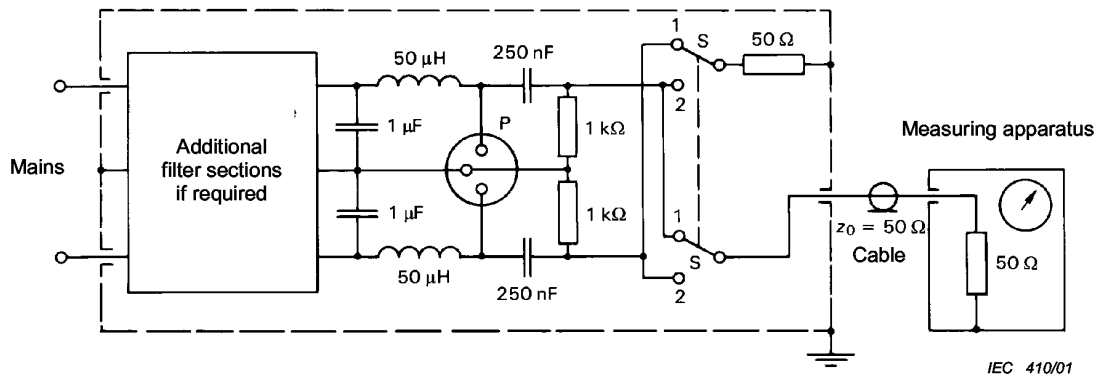

P = Connections for equipment under test

Figure 3 – Example of an artificial mains network 50 Ω-50 μH (see 5.3.1)

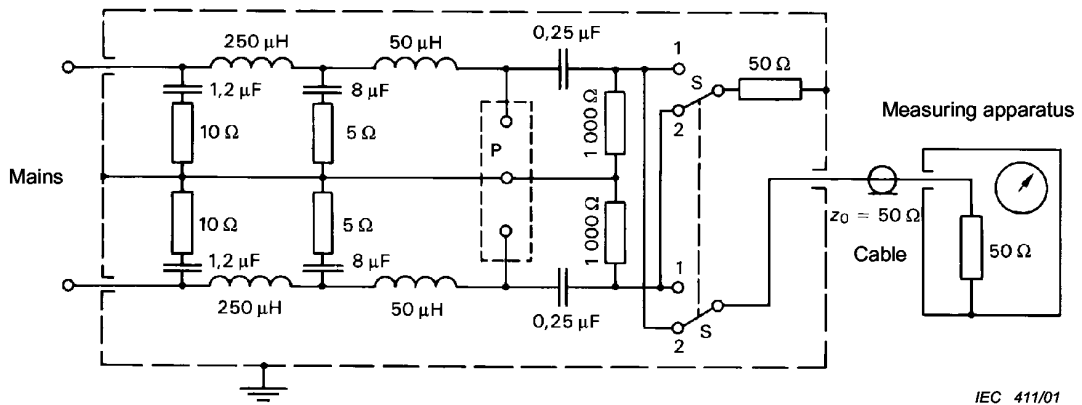

P = Connections for equipment under test

Figure 4 – Example of artificial mains network 50 Ω-50 μH-5 Ω (see 5.3.1)

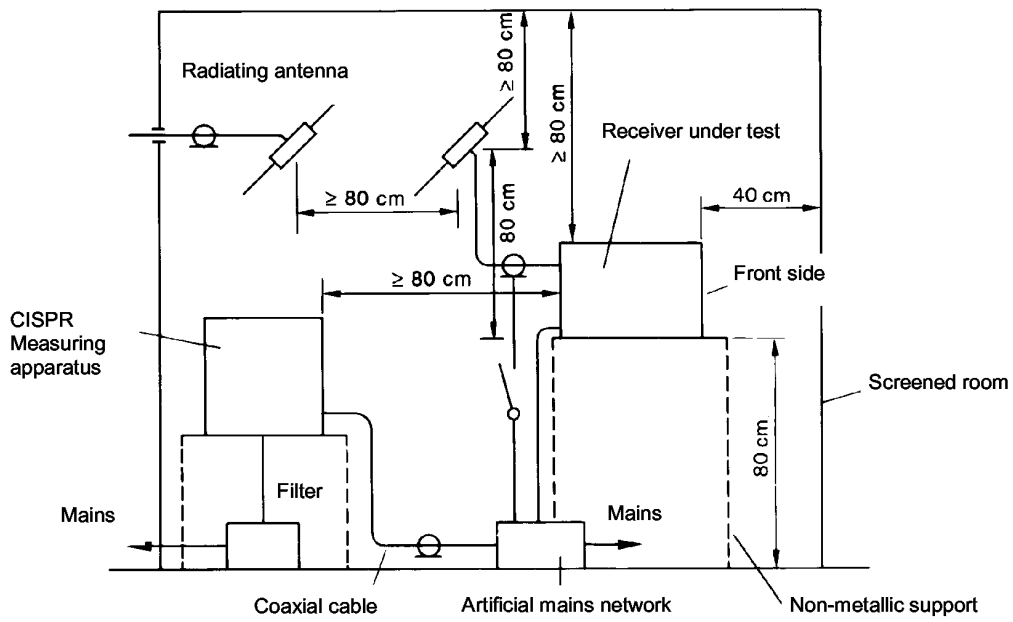

IEC 412/01

Figure 5 – Measurement of the radiofrequency disturbance voltage injected into the mains (see 5.3.1)

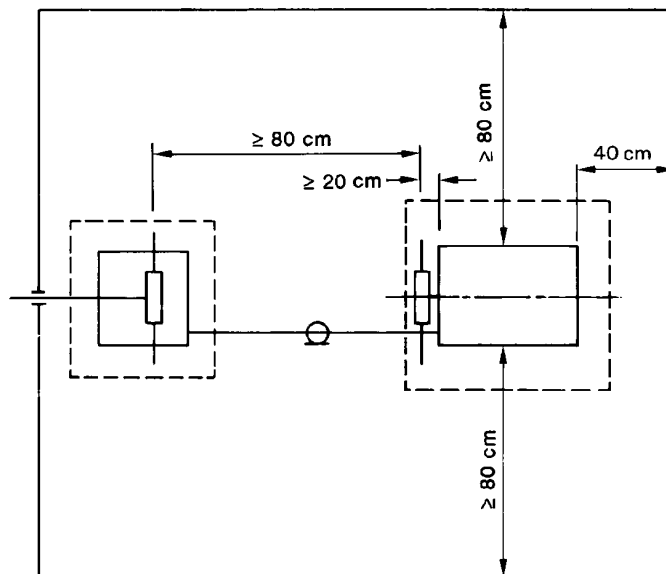

IEC 413/01

Figure 6 – Measurement of the radiofrequency disturbance voltage injected into the mains (top view) (see 5.3.1)

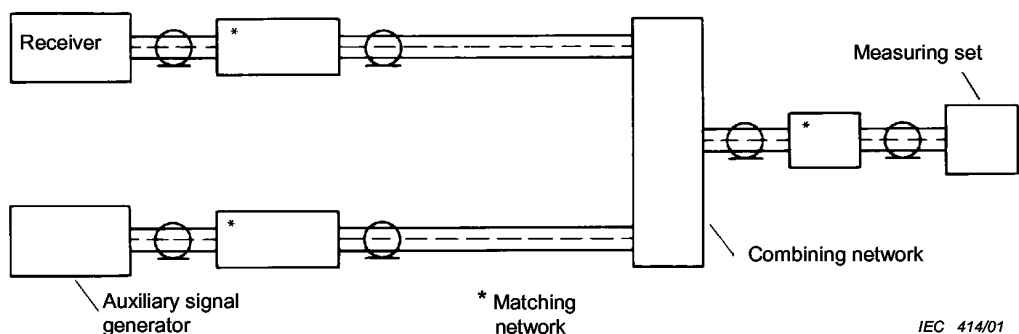
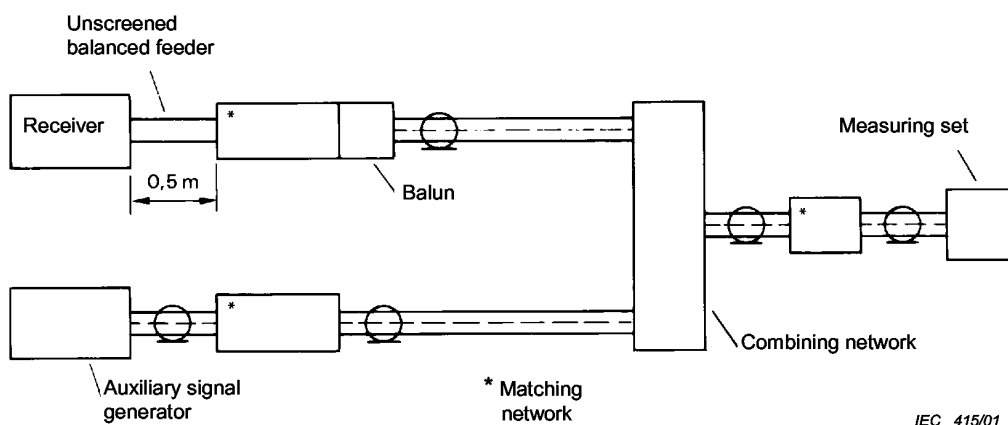

Figure 7 – Circuit arrangement for the measurement of disturbance voltages at the coaxial antenna terminals (see 5.4.2)



NOTE The balun may include a device to suppress any asymmetric currents.

Figure 8 – Circuit arrangement for receivers with balanced antenna connections (see 5.4.3)

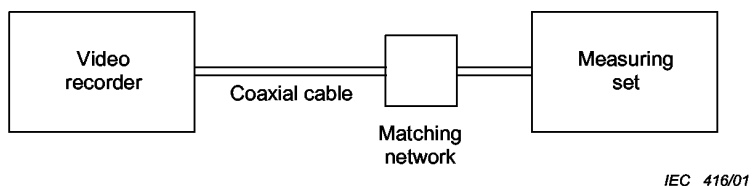
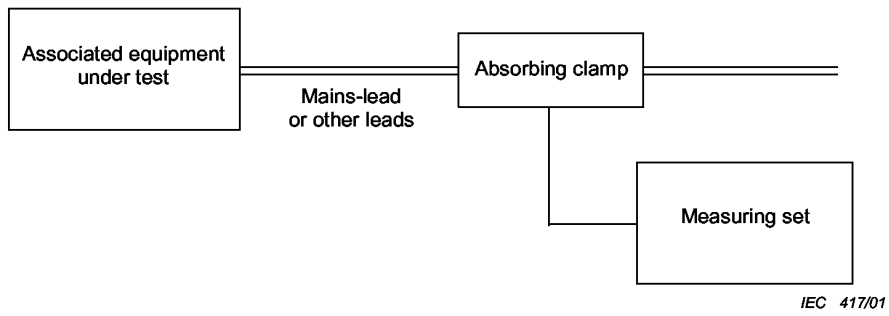
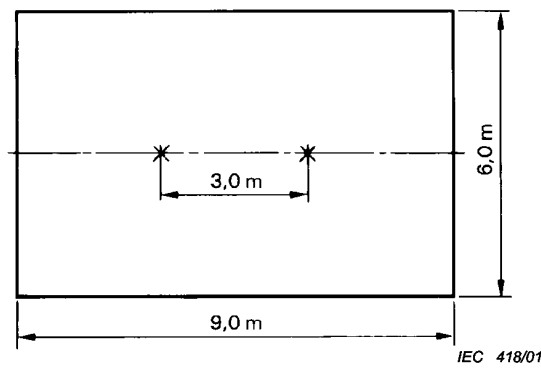

Figure 9 – Circuit arrangement for the measurement of the wanted signal and disturbance voltage at the RF output of video recorders (see 5.5.2)



IEC 417/01

Figure 10 – Circuit arrangement for the measurement of disturbance power of associated equipment (video recorders excluded) (see 5.6.3)



IEC 418/01

Figure 11 – Measuring site (see 5.7.2)

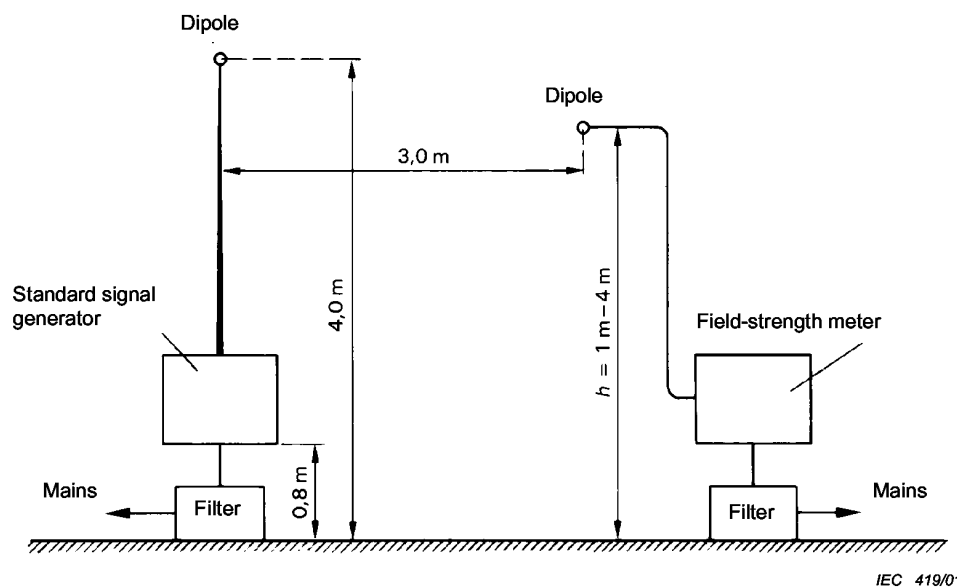

IEC 419/01

Figure 12 – Check of the site suitability (see 5.7.2)

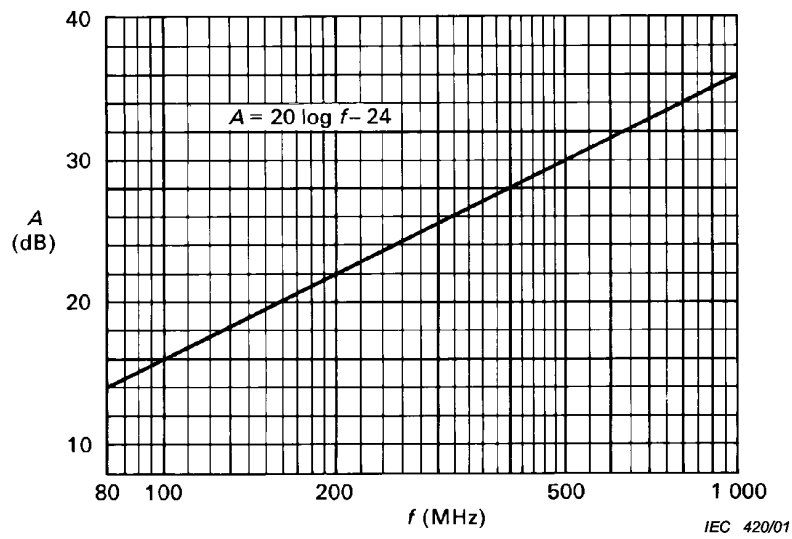
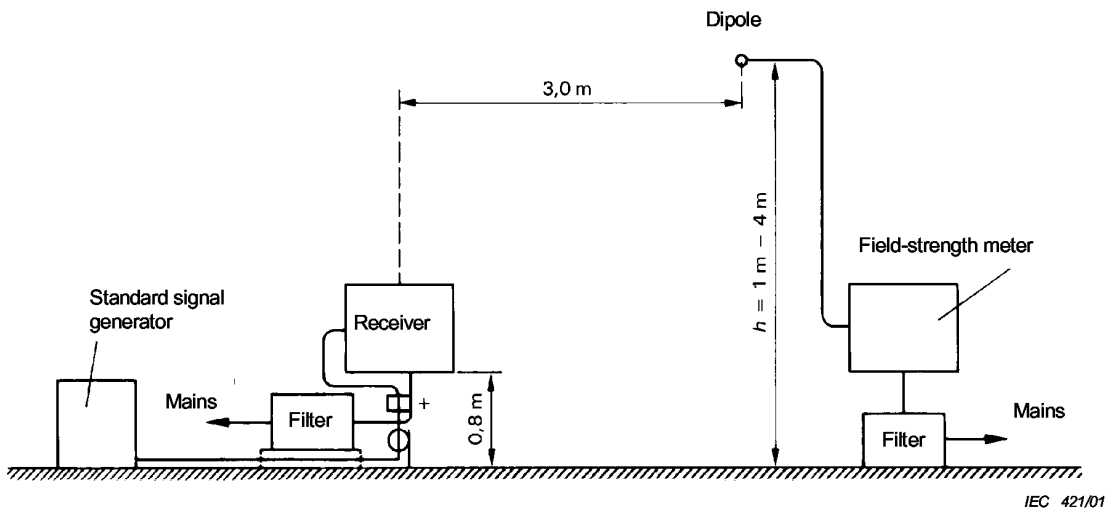

Figure 13 – Theoretical site attenuation curve for the range 80 MHz to 1 GHz (see 5.7.2)



+ Coaxial rotating connector (if necessary)

Figure 14 – Open-field measurement at 3 m distance (see 5.7.3)



Annex A (normative)

Broadcast receivers for digital signals

A.1 Introduction

This annex gives additional information concerning the methods of measurement of broadcast receivers for digital signals.

Receivers can be equipped with telecom or data connectors and may contain storage and return channel facilities.

For the measurements at ports related to non-broadcast functions, for example, the Telecom and LAN ports, reference is made to the relevant standards, for example, CISPR 22.

A.2 Normative references

See Clause 2.

A.3 Definitions

For the purposes of this annex, the following definitions apply.

A.3.1

digital sound receivers

appliances intended for the reception of sound broadcast, associated data and similar services for digital terrestrial, cable and satellite transmissions

A.3.2

digital television receivers

appliances intended for the reception of television broadcast, data and similar services for digital terrestrial, cable and satellite transmissions. The receiver can be equipped with a display. Receivers without a display are generally referred to as set-top boxes

A.3.3

digital sound signal

RF signal modulated with a digital data stream containing sound information. Data concerning additional services and service provider dependent applications may be included in the data stream

A.3.4

digital television signal

RF signal modulated with a digital data stream containing video and accompanying sound information. Information concerning the supplied additional services and service provider dependent applications, like the Electronic Programme Guide, may be included in the data stream

NOTE Annex B gives information on signals for terrestrial, cable and satellite systems.





A.4 Limits of disturbance

The relevant limits of Clause 4 apply.

A.5 Measurement procedures

A.5.1 General

See Clause 5.

A.5.2 Measurement of the disturbance voltage at the mains terminals of digital satellite receivers

For digital satellite receivers an isolation transformer shall be used to supply the wanted signal instead of the small pick-up antenna specified in 5.3.2 (see Figure A.1). The maximum crossover capacitance of the transformer is 7,5 pF. This leads to a minimum common-mode impedance of the isolation transformer of 700 Ω at 30 MHz. An example of an isolation transformer and its performance is given in Figures A.2, A.3 and A.4.

NOTE This transformer can also be used for other types of receivers, for example, for terrestrial receivers.

A.5.3 Wanted signals

A.5.3.1 General

The level of a digital television or sound signal is expressed in dB(μ V) across the nominal impedance of 75 Ω ; it relates to the signal power of the signal, which is defined as the mean power of the selected signal as measured with a thermal power sensor.

Care should be taken to limit the measurement to the bandwidth of the signal. When using a spectrum analyser or calibrated receiver, it should integrate the signal power within the nominal bandwidth of the signal.

A.5.3.2 Digital sound signal

The level of the digital sound signal is 50 dB(μ V).

The reference level of all sound channels shall be at full range -6 dB at 1 kHz.

A.5.3.3 Digital television signal

The level of the digital television signals during the test shall be

- for terrestrial systems: VHF 50 dB(μ V), UHF 54 dB(μ V),
- for cable systems: 60 dB(μ V),
- for satellite systems: 60 dB(μ V).

The standard picture is a test pattern consisting of vertical colour bars in accordance with ITU-R BT471-1 Recommendation with a small moving element, coded at 6 Mbit/s.

The reference level of all sound channels shall be at full range -6 dB at 1 kHz.

See further Annex B.





A.5.4 Receivers for digital and analogue signals

All measurements shall be performed in the digital mode. In case separate tuners are used for digital and analogue reception, the measurements of the emission at the local oscillator frequency and its harmonics shall be performed in addition in the analogue mode.



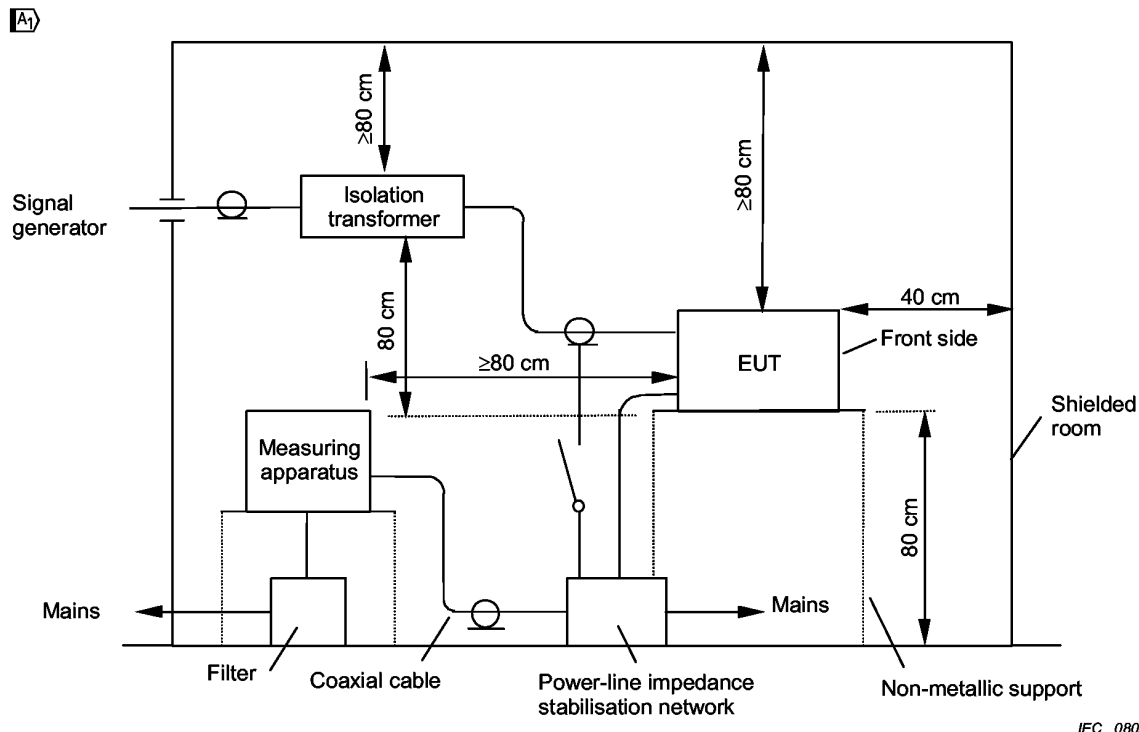

IEC 080/03

Figure A.1 – Measurement of the radiofrequency disturbance voltage injected into the mains (see 5.1.3 and 5.1.4) in the frequency range 150 kHz to 30 MHz (side view)

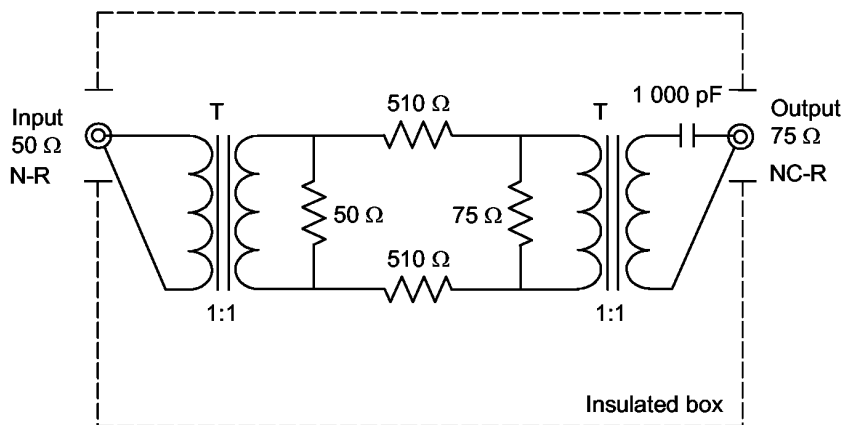

IEC 081/03

Frequency band: 46 MHz to 1,5 GHz
 Insertion loss: 30 dB
 Input impedance: 50 Ω
 Input connector: N-R
 Output impedance: 75 Ω
 Output connector: NC-R
 Chassis: Insulated material

Figure A.2 – Example of isolation transformer for 46 MHz to 1,5 GHz

A1

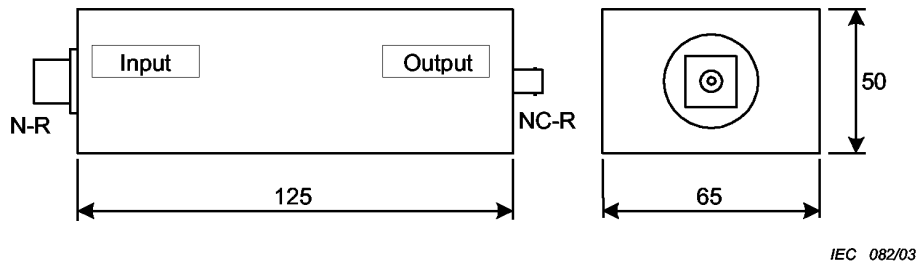

Figure A.3 – Typical size of isolation transformer for 46 MHz to 1,5 GHz

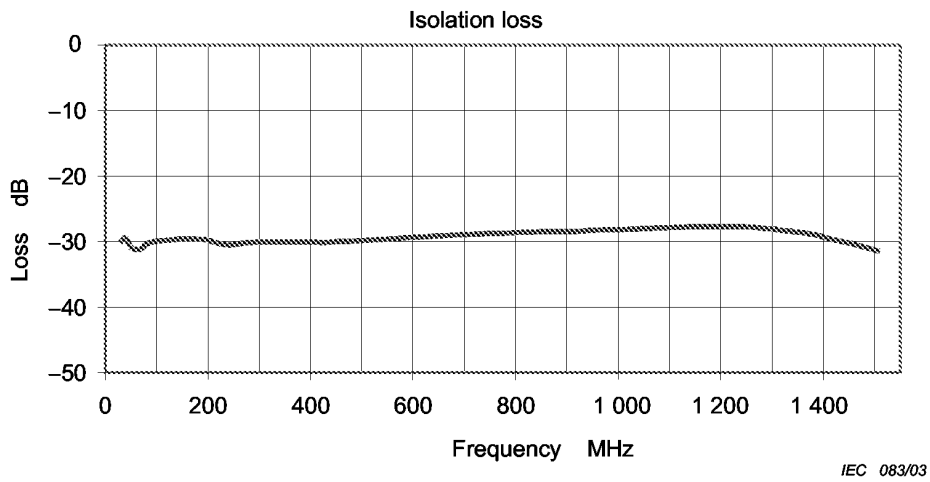

Figure A.4 – Typical characteristic of insertion loss of isolation transformer for 46 MHz to 1,5 GHz

A1



Annex B
(informative)

Specification of the wanted signal

B.1 General

Europe	TR 101154
Source coding	MPEG-2 video MPEG-2 audio
Video elementary stream	Colour bar, with small moving element
Video bit rate	6 Mbit/s
Audio elementary stream for reference measurement	1 kHz/full range –6 dB
Audio elementary stream for noise measurement	1 kHz/silence
Audio bit rate	192 kbit/s

Japan	
Source coding	MPEG-2 video MPEG-2 audio
Data coding	Optional
Video elementary stream	Colour bar, with small moving element
Video bit rate	6 Mbit/s
Audio elementary stream for reference measurement	1 kHz/full range –6 dB
Audio elementary stream for noise measurement	1 kHz/silence
Audio bit rate	192 kbit/s

USA	ATSC Standard A/53B with Amendment 1
Source coding	MPEG-2 video AC-3 audio
Video elementary stream	Colour bar, with small moving element
Video bit rate	6 Mbit/s
Audio elementary stream for reference measurement	1 kHz/full range –6 dB
Audio elementary stream for noise measurement	1 kHz/silence
Audio bit stream	192 kbit/s





B.2 Terrestrial TV

Europe	EN 300 744
Level	50 dB(μ V) / 75 Ω -VHF BIII 54 dB(μ V) / 75 Ω -UHF BIV/V
Channel	9, 25 or 55
Modulation	OFDM
Mode	2 k or 8 k
Modulation scheme	64 QAM
Guard interval	1/32
Code rate	2/3
Useful bit rate	24,128 Mbit/s

Japan	ARIB STD-B21 Version 3.1 ARIB STD-B31 Version 1.2
Level	34 dB(μ V) to 89 dB(μ V) / 75 Ω
Frequency	470 MHz to 770 MHz, 5,7 MHz bandwidth
Modulation	OFDM
Mode (carrier spacing)	4 k, 2 k, 1 k
Carrier modulation	QPSK, DQPSK, 16 QAM, 64 QAM
Guard interval	1/4, 1/8, 1/16, 1/32
Code rate	1/2, 2/3, 3/4, 5/6, 7/8
Information bit rate: maximum	23,224 Mbit/s

USA	ATSC 8VSB
Level	54 dB(μ V) (ATSC 64 see 4.2.5)
Channel	2 to 69
Modulation	8 VSB or 16 VSB
Code rate	2/3
Useful bit rate	19,39 Mbit/s





B.3 Satellite TV

Europe	EN 300 421
Level	60 dB(μ V) / 75 Ω
Frequency	1 550 MHz
Modulation	QPSK
Code rate	3/4
Useful bit rate	38,015 Mbit/s

Japan (Communication satellite)	ARIB STD-B1 Version 1.4
Level	48 dB(μ V) to 81 dB(μ V) / 75 Ω
Frequency 1st IF	1 000 MHz to 1 550 MHz, 27 MHz bandwidth
Parameters for CS digital broadcasting	
Transmission frequency	12,5 GHz to 12,75 GHz
Modulation	QPSK
Code rate	1/2, 2/3, 3/4, 5/6, 7/8
Information bit rate	34,0 Mbit/s

Japan (Broadcasting satellite)	ARIB STD-B20 Version 3.0 ARIB STD-B21 Version 3.1
Level	48 dB(μ V) to 81 dB(μ V) / 75 Ω
Frequency 1 st IF	1 032 MHz to 1 489 MHz, 34,5 MHz bandwidth
Parameters for BS digital broadcasting	
Transmission frequency	11,7 GHz to 12,2 GHz
Modulation	TC8PSK, QPSK, BPSK
Code rate	1/2, 2/3, 3/4, 5/6, 7/8
Information bit rate: maximum	52,0 Mbit/s





B.4 Cable TV

Europe	EN 300 429
Level	60 dB(μ V) / 75 Ω
Frequency	Hyperband channel closest to 375 MHz
Modulation	64 QAM
Useful bit rate	38,015 Mbit/s

Japan	JCTEA STD-002-1.0 (Multiplex System for Digital Cable Television) JCTEA STD-004-1.0 (Receiver for Digital Cable Television)
Level	53 dB(μ V) to 85 dB(μ V) / 75 Ω
Frequency	90 MHz to 770 MHz, 6 MHz bandwidth
Parameters for CATV digital broadcasting	
Modulation	64 QAM
Transmission bit rate	31,644 Mbit/s
Information bit rate	29,162 Mbit/s

USA	ANSI/SCTE 07 2000
Level	60 dB(μ V) / 75 Ω
Frequency	88 MHz to 860 MHz
Modulation	64 QAM or 256 QAM
Useful bit rate	26,970 Mbit/s (64 QAM), 38,810 Mbit/s (256 QAM)
Return path	5 MHz to 40 MHz, QPSK





B.5 Reference documents

B.5.1 American standards

ATSC Standard A/53B with amendment 1	Digital Television Standard
ANSI/SCTE 07 2000	Digital Video Transmission Standard for Television

B.5.2 ETSI publications for the DVB system

EN 300421	Framing structure, channel coding and modulation for 11/12 GHz satellite services
EN 300429	Framing structure, channel coding and modulation for cable systems
EN 300744	Framing structure, channel coding and modulation for digital terrestrial television
TR 101154	Implementation guidelines for the use of MPEG-2 systems, video and audio in satellite, cable and terrestrial broadcasting applications

B.5.3 Japanese standards

ARIB STD-B1 Version 1.4	Digital receiver for digital satellite broadcasting services using communication satellites
ARIB STD-B20 Version 3.0	Transmission system for digital satellite broadcasting
ARIB STD-B21 Version 3.1	Receiver for digital broadcasting
ARIB STD-B31 Version 1.2	Transmission system for digital terrestrial television broadcasting
JCTEA STD-002-1.0	Multiplex system for digital cable television
JCTEA STD-004-1.0	Receiver for digital cable television



Annex ZA
 (normative)

**Normative references to international publications
 with their corresponding European publications**

This European Standard incorporates by dated or undated reference, provisions from other publications. These normative references are cited at the appropriate places in the text and the publications are listed hereafter. For dated references, subsequent amendments to or revisions of any of these publications apply to this European Standard only when incorporated in it by amendment or revision. For undated references the latest edition of the publication referred to applies (including amendments).

NOTE When an international publication has been modified by common modifications, indicated by (mod), the relevant EN/HD applies.

<u>Publication</u>	<u>Year</u>	<u>Title</u>	<u>EN/HD</u>	<u>Year</u>
CISPR 16-1	1999	Specification for radio disturbance and immunity measuring apparatus and methods Part 1: Radio disturbance and immunity measuring apparatus	-	-
CISPR 16-2	1996	Part 2: Methods of measurement of disturbances and immunity	-	-
CISPR 22 (mod)	1997	Information technology equipment - Radio disturbance characteristics - Limits and methods of measurement	EN 55022	1998
IEC 60050-161	1990	International Electrotechnical Vocabulary (IEV) - Chapter 161: Electromagnetic compatibility	-	-
IEC 60728-2		Cabled distribution systems for television and sound signals Part 2: Electromagnetic compatibility of equipment	-	-
ITU-R BT.471-1	1994	Nomenclature and description of colour bar signals	-	-

Bibliography

CISPR 11, *Industrial, scientific and medical (ISM) radio-frequency equipment – Electro-magnetic disturbance characteristics – Limits and methods of measurement*

Ⓒ NOTE CISPR 11:1997,mod., is harmonized as EN 55011:1998. Ⓒ

BSI — British Standards Institution

BSI is the independent national body responsible for preparing British Standards. It presents the UK view on standards in Europe and at the international level. It is incorporated by Royal Charter.

Revisions

British Standards are updated by amendment or revision. Users of British Standards should make sure that they possess the latest amendments or editions.

It is the constant aim of BSI to improve the quality of our products and services. We would be grateful if anyone finding an inaccuracy or ambiguity while using this British Standard would inform the Secretary of the technical committee responsible, the identity of which can be found on the inside front cover.
Tel: +44 (0)20 8996 9000. Fax: +44 (0)20 8996 7400.

BSI offers members an individual updating service called PLUS which ensures that subscribers automatically receive the latest editions of standards.

Buying standards

Orders for all BSI, international and foreign standards publications should be addressed to Customer Services. Tel: +44 (0)20 8996 9001.

Fax: +44 (0)20 8996 7001. Email: orders@bsi-global.com. Standards are also available from the BSI website at <http://www.bsi-global.com>.

In response to orders for international standards, it is BSI policy to supply the BSI implementation of those that have been published as British Standards, unless otherwise requested.

Information on standards

BSI provides a wide range of information on national, European and international standards through its Library and its Technical Help to Exporters Service. Various BSI electronic information services are also available which give details on all its products and services. Contact the Information Centre.
Tel: +44 (0)20 8996 7111. Fax: +44 (0)20 8996 7048. Email: info@bsi-global.com.

Subscribing members of BSI are kept up to date with standards developments and receive substantial discounts on the purchase price of standards. For details of these and other benefits contact Membership Administration.

Tel: +44 (0)20 8996 7002. Fax: +44 (0)20 8996 7001.
Email: membership@bsi-global.com.

Information regarding online access to British Standards via British Standards Online can be found at <http://www.bsi-global.com/bsonline>.

Further information about BSI is available on the BSI website at <http://www.bsi-global.com>.

Copyright

Copyright subsists in all BSI publications. BSI also holds the copyright, in the UK, of the publications of the international standardization bodies. Except as permitted under the Copyright, Designs and Patents Act 1988 no extract may be reproduced, stored in a retrieval system or transmitted in any form or by any means – electronic, photocopying, recording or otherwise – without prior written permission from BSI.

This does not preclude the free use, in the course of implementing the standard, of necessary details such as symbols, and size, type or grade designations. If these details are to be used for any other purpose than implementation then the prior written permission of BSI must be obtained.

Details and advice can be obtained from the Copyright & Licensing Manager.
Tel: +44 (0)20 8996 7070. Fax: +44 (0)20 8996 7553.
Email: copyright@bsi-global.com.