

# SSP 沉水式不銹鋼污水泵浦



ISO 9002、ISO 14001 CE  
綠色 安全 永續經營  
**GSD INDUSTRIAL CO., LTD.**

## 用途:

- 一、大樓地下排放設備·下水道排水工程。
- 二、土木建築工程施工。
- 三、農業灌溉及畜牧排水。
- 四、船艙積水·污水排放。
- 五、污水處理場之污水輸送。

## 特點:

- 一、本產品採用不銹鋼及工程塑膠為材質·重量輕。
- 二、本產品流道及葉輪一體成型·損失少·效率高·達到節省能源功能。
- 三、長期使用於一般污水中不生銹·不會產生二次污染·符合環保要求。
- 四、適用液體溫度: 0~40℃。
- 五、機械軸封: 雙機械密封·軸封材質為碳化矽
- 六、馬達: 鼠籠式感應電動機·F級絕緣并符合IP68

## 標準配備:

- 一、防水電纜5米
- 二、銜接凸緣: PP製一個
- 三、附出口排氣閥
- 四、過熱保護器

## 選擇配件:

- 一、自動着脫裝置  
使泵浦安裝保養修護容易·毋須先清除桶槽污水
- 二、控制盤及浮球開關〈3相〉使泵浦可以交互並替操作
- 三、單相使用浮球開關
- 四、不銹鋼材質·可依客戶需求採用SUS316

## APPLICATIONS:

1. Basement Drainage. Sewage Drainage Engineering.
2. Construction Engineering.
3. Agricultural irrigation and Livestock Industry Drainage.
4. Discharges of Accumulated Water and Sewage from ships.
5. Transportation of Swage from Swage Treatment Terminal.

## FEATURES:

1. Product material of stainless steel and industrial plastic light in weight.
2. Monoblock impeller and passageway highly efficient with less energy loss, achieving energy saving purposes.
3. No rusting and corrosion even after long period of operations, no secondary pollution, and complies with environmental protection requirement.
4. Liquid temperature: 0 ~ 40℃
5. Mechanical Seal: Double Mechanical Seals. material using for seal ring and floating seat is Silicon Carbide.
6. Motor: Squirrel Cage Induction Motor, F Class insulation and in accordance with IP68.

## STANDARD ACCESSORIES:

1. Waterproof cable is in 5M length.
2. Companion flange is made of PP+SPG.
3. With outlet vent valve.
4. Thermostat.

## OPTIONAL ACCESSORIES:

1. **AUTO-SETTER**  
- to allow pump for easy installation, maintenance, and repair, as it is no need to empty tank first.
2. **CONTROL PANEL & FLOAT SWITCH**  
- to allow automatic pump operations, enabling alternating and parallel operations also.
3. Single phase operated float switch.
4. Stainless steel made parts of pump may choose the use of SUS316 according to the customers' need.

## 規格表 SPECIFICATIONS

型式 TYPE	馬達 MOTOR					泵浦 PUMP				泵浦重量 PUMP WEIGHT
	出力		相數	極數	電頻	口徑 DISCH. DIA	揚程 HEAD	水量 CAP.	kg	
	kW	HP	Phase	Pole	Hz	mm	in	m		LPM
SSP-60.4-50(S)	0.4	0.5	3(1)	2	60	50	2"	7	165	11.5
SSP-60.75-50(S)	0.75	1	3(1)	2	60	50	2"	10	240	14
SSP-61.5-50	1.5	2	3	2	60	50	2"	14	240	15.5
SSP-61.5-80	1.5	2	3	2	60	80	3"	14	330	19
SSP-62.2-80	2.2	3	3	2	60	80	3"	15	410	22
SSP-63.7-80	3.7	5	3	2	60	80	3"	20	500	24

60Hz

型式 TYPE	馬達 MOTOR					泵浦 PUMP				泵浦重量 PUMP WEIGHT
	出力		相數	極數	電頻	口徑 DISCH. DIA	揚程 HEAD	水量 CAP.	kg	
	kW	HP	Phase	Pole	Hz	mm	in	m		LPM
SSP-50.4-50(S)	0.4	0.5	3(1)	2	50	50	2"	7.5	150	11.5
SSP-50.75-50(S)	0.75	1	3(1)	2	50	50	2"	10	220	14
SSP-51.5-50	1.5	2	3	2	50	50	2"	14	265	15.5
SSP-51.5-80	1.5	2	3	2	50	80	3"	14	340	19
SSP-52.2-80	2.2	3	3	2	50	80	3"	15	450	22
SSP-53.7-80	3.7	5	3	2	50	80	3"	20	550	24

50Hz

## 性能曲線 PERFORMANCE CURVE

備註: 電壓可依客戶需求製作

PS: Different voltages may be selected subject to customers' needs.

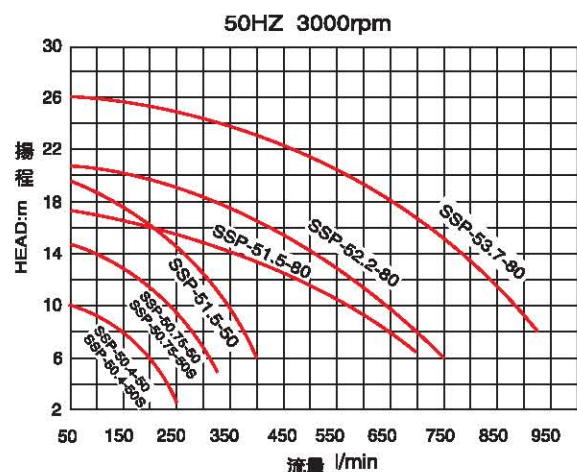
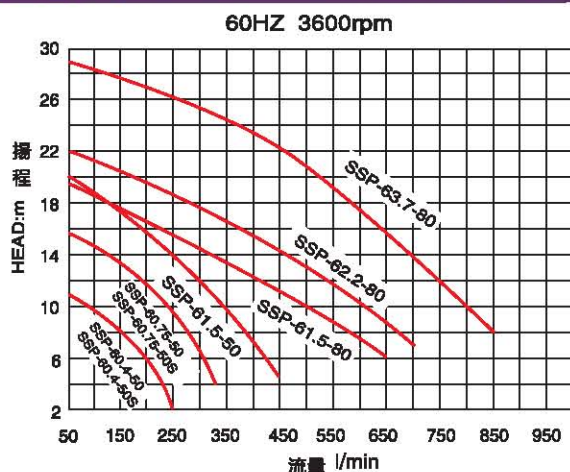

## 材質結構表 MATERIAL LIST

NO.	名稱 NAME	材質 MATERIAL
001	電 纜 CABLE	VCT
003	軸 承 座 BEARING COVER	SUS304
004	馬 達 蓋 MOTOR COVER	SUS304
005	馬達本體 MOTOR CASING	SUS304
006	軸 承 BEARING	NSK (or SKF)
008	定 子 STATOR	F CLASS
010	主 軸 SHAFT	SUS410
012	中 承 座 BRACKET	PP
013	泵浦本體 PUMP CASING	PP+SUS304
016	葉 輪 IMPELLER	PP
017	濾 底 座 STRAINER	SUS304
018	機 械 軸 封 MECH. SEAL	CARBON/SILICON
020	凸 緣 FLANGE	PP
050	螺 栓 BOLT	SUS304
053	墊 片 BRACKET GASKET	PP
152	過熱保護器 THERMOSTAT	-

## 結構圖 CONSTRUCTION

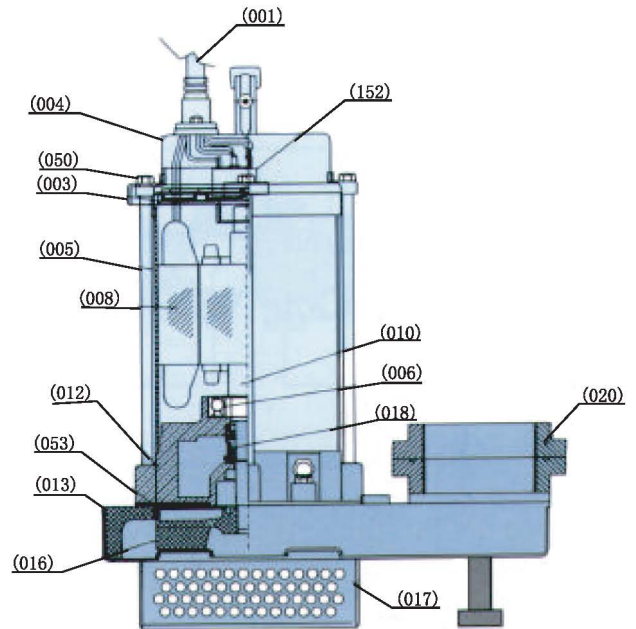

## 外型尺寸圖

### DIMENSIONS (WITHOUT AUTOSETTER)

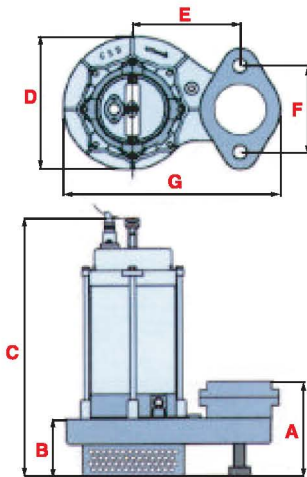

## 型號說明 TYPE DESCRIPTION

### SSP-6-0.4-50(S)

- 單相標示: PHASE S: SINGLE
- 出口口徑: OUTLET DIAMETER (mm)
- 額定動力: RATED POWER (kW)
- 電頻: Hz 6: 60Hz 5: 50Hz (Hz)
- SSP: 機型 MODELS TYPE

## 外型尺寸規格表

### DIMENSIONS (WITHOUT AUTOSETTER)

(mm)

機型 TYPE	A	B	C	D	E	F	G	機型 TYPE	A	B	C	D	E	F	G
SSP-50.4-50S	138	85	395	190	122	98	257	SSP-60.4-50S	138	85	395	190	122	98	257
SSP-50.4-50	138	85	395	190	122	98	257	SSP-60.4-50	138	85	395	190	122	98	257
SSP-50.75-50S	138	85	463	190	122	98	257	SSP-60.75-50S	138	85	455	190	122	98	257
SSP-50.75-50	138	85	423	190	122	98	257	SSP-60.75-50	138	85	415	190	122	98	257
SSP-51.5-50	138	85	463	190	122	98	257	SSP-61.5-50	138	85	463	190	122	98	257
SSP-51.5-80	163	100	438	230	180	150	362	SSP-61.5-80	163	100	438	230	180	150	362
SSP-52.2-80	163	100	458	230	180	150	362	SSP-62.2-80	163	100	458	230	180	150	362
SSP-53.7-80	163	100	498	230	180	150	362	SSP-63.7-80	163	100	498	230	180	150	362

本型錄內容如有變更恕不另通知

We reserve the right to change content without notice.

着脱式外型尺寸圖  
DIMENSIONS (WITH AUTOSETTER)

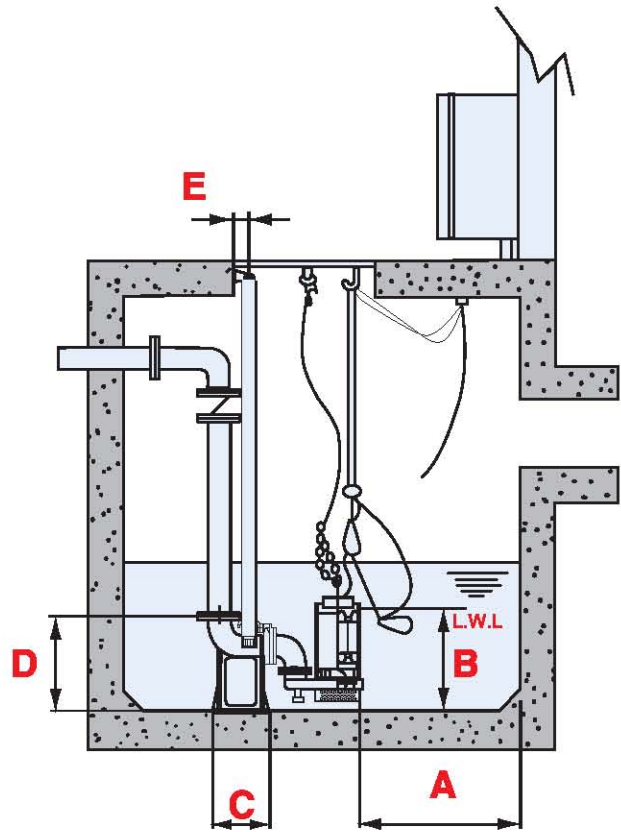
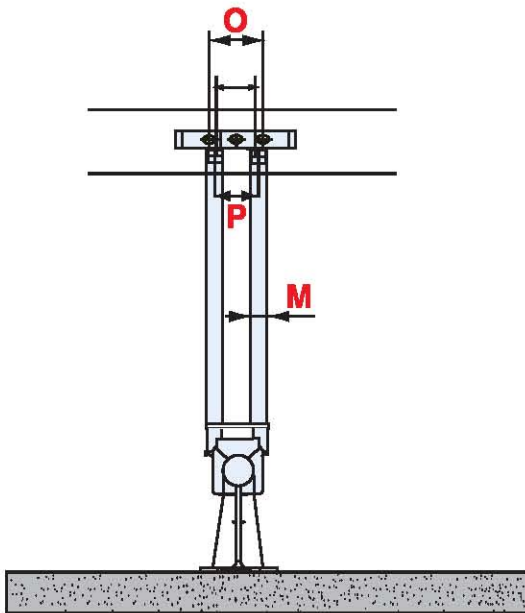
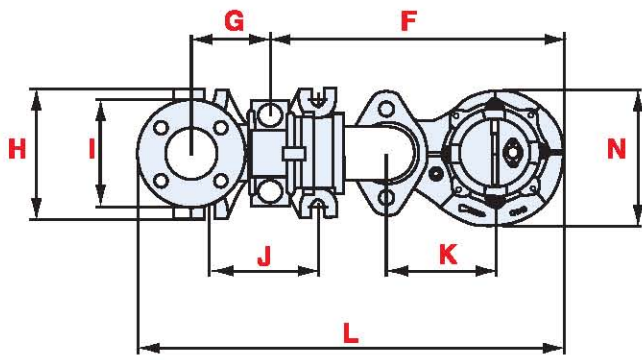

着脱式外型尺寸規格表  
DIMENSIONS (WITH AUTOSETTER)

(mm)

機型 TYPE	A	B	C	D	E	F	G	H	I	J	K	L	M	N	O	P
SSP-50	>1500	355	180	310	59	318	130	150	120	110	122	518	25A	190	140	135
SSP-80	>1500	415	226	434	59	458	163	220	180	180	180	713	25A	230	140	135

Agent: