

FEATURES	DESCRIPTION
----------	-------------

- > 90% Efficiency
- Universal rectified 85 – 265V_{AC} input range
- Constant-current LED driver
- Applications from a few mA to more than 1A Output
- LED string from one to hundreds of diodes
- PWM Low-Frequency Dimming via Enable pin
- Input Voltage Surge ratings up to 500V
- Internal thermal overload protection

The SMD802 is a PWM high-efficiency LED driver control IC. It allows efficient operation of High Brightness (HB) LEDs from voltage sources ranging from 85V_{AC} up to 265V_{AC}. The SMD802 controls an external MOSFET at fixed switching frequency up to 300kHz. The frequency can be programmed using a single external resistor. The LED string is driven at constant current rather than constant voltage, thus providing constant light output and enhanced reliability. The output current can be programmed between a few milliamps and up to more than 1.0A.

SMD802 uses a rugged high voltage junction isolated process that can withstand an input voltage surge of up to 500V. Output current to an LED string can be programmed to any value between zero and its maximum value by applying an external control voltage at the linear dimming control input of the SMD802. The SMD802 provides a low-frequency PWM dimming input that can accept an external control signal with a duty ratio of 0-100% and a frequency of up to a few kilohertz.

APPLICATIONS	
--------------	--

- AC/DC LED Driver applications
- RGB Backlighting LED Driver
- Back Lighting of Flat Panel Displays
- General purpose constant current source
- Signage and Decorative LED Lighting
- Chargers

PACKAGE/ORDER INFORMATION	
---------------------------	--

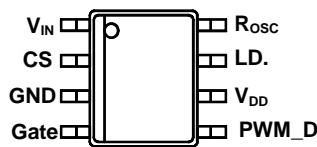

8-Pin Plastic S.O.I.C.
(Top View)

Order Part Number

SMD802MST

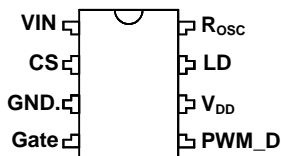

8-Pin Plastic DIP
(Top View)

SMD802M

PIN FUNCTIONS

Pin No.	Pin Name	Function
1	V _{IN}	Input voltage
2	CS	Senses LED string current
3	GND	Device ground
4	GATE	Drives the gate of the external MOSFET
5	PWM_D	Low Frequency PWM Dimming pin, also Enable input. Internal 100kΩ pull-down to GND
6	V _{DD}	Internally regulated supply voltage. 7.5V nominal. Can supply up to 1 mA for external circuitry. A sufficient storage capacitor is used to provide storage when the rectified AC input is near the zero crossings.
7	LD	Linear Dimming by changing the current limit threshold at current sense comparator
8	R _{OSC}	Oscillator control. A resistor connected between this pin and ground sets the PWM frequency.

ABSOLUTE MAXIMUM RATINGS (Note 1)

V_{IN} to GND	-0.5V to +520V
CS	-0.3V to ($V_{DD} + 0.3V$)
LD, PWM_D to GND	-0.3V to ($V_{DD} - 0.3V$)
GATE to GND	-0.3V to ($V_{DD} + 0.3V$)
V_{DDMAX}	13.5V
Continuous Power Dissipation ($T_A = 25^\circ C$) (Note 1)	
8 Pin DIP (derate 9mW/ $^\circ C$ above $+25^\circ C$)	900mW
8 Pin SO (derate 6.3mW/ $^\circ C$ above $+25^\circ C$)	630mW
Operating Temperature Range	$-40^\circ C$ to $+85^\circ C$
Junction Temperature	$+125^\circ C$
Storage Temperature Range	$-65^\circ C$ to $+150^\circ C$

Note 1: Exceeding these ratings could cause permanent damage to the device. All voltages are with respect to ground. Currents are positive into, negative out of the specified terminal.

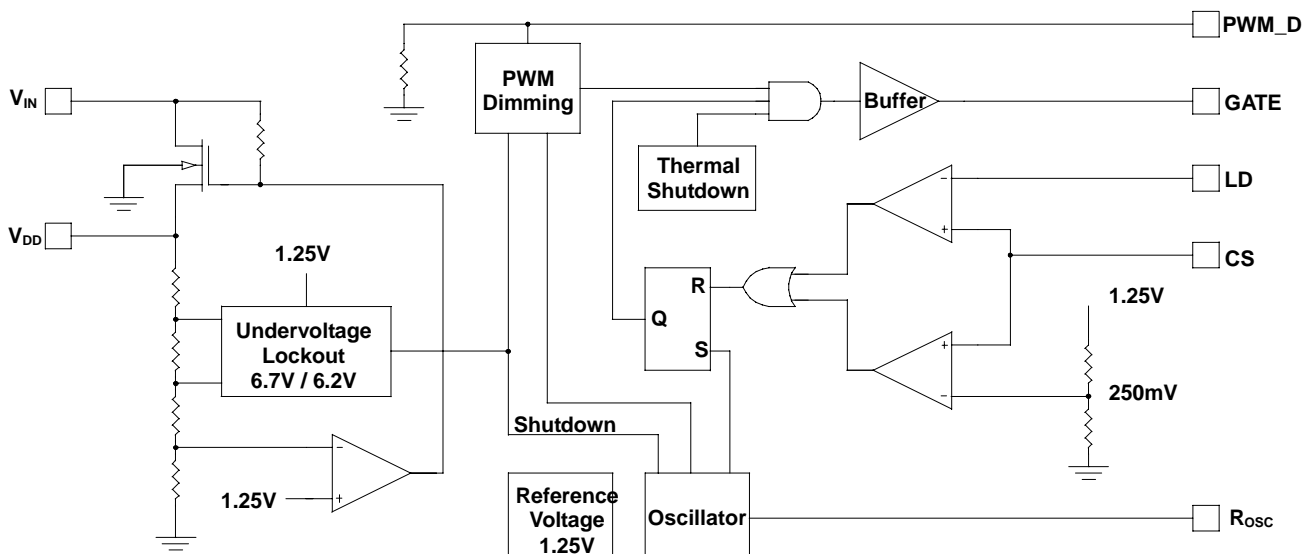
BLOCK DIAGRAM

TYPICAL APPLICATIONS**Universal Input**

15V – 500 V_{DC}
85 – 265 V_{AC}
rectified

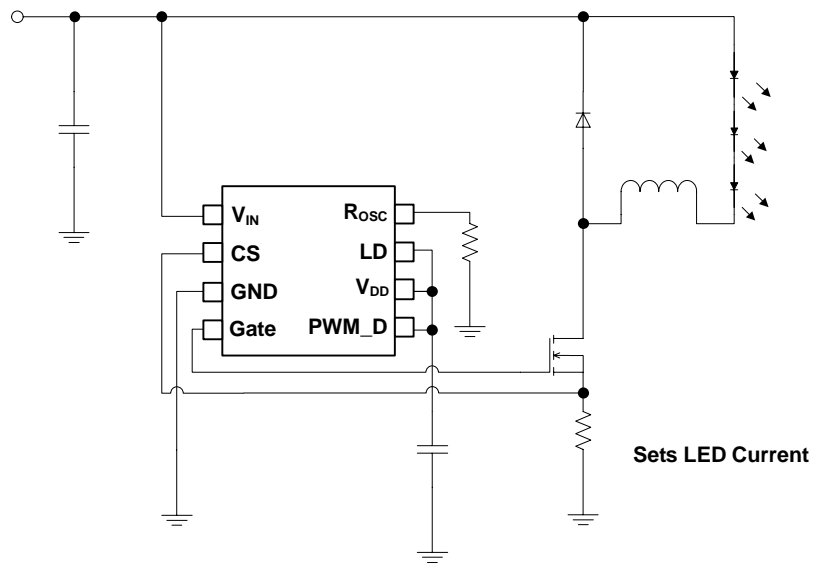

ELECTRICAL CHARACTERISTICS Unless otherwise specified, $T_A = 25^\circ\text{C}$.

Parameter	Test Conditions	Symbol	Min	Typ	Max	Units
Input DC supply voltage range	DC input voltage	V_{INDC}	15.0		500	V
Shut-Down mode supply current	Pin PWM_D to GND, $V_{\text{IN}} = 15\text{V}$	I_{INsd}		0.5	1	mA
Internally regulated voltage	$V_{\text{IN}} = 15\text{-}500\text{V}$, $I_{\text{DD(ext)}}=0$, pin Gate open	V_{DD}	7.0	7.5	8.0	V
Maximal pin Vdd voltage	When an external voltage applied to pin Vdd	V_{DDmax}			13.5	V
V_{DD} current available for external circuitry ¹	$V_{\text{IN}} = 15\text{-}100\text{V}$	$I_{\text{DD(ext)}}$			1.0	mA
V_{DD} under voltage lockout threshold	Vin rising	UVLO	6.45	6.7	6.95	V
V_{DD} under voltage lockout hysteresis	Vin falling	ΔUVLO		500		mV
Pin PWM_D input low voltage	$V_{\text{IN}} = 15\text{-}500\text{V}$	$V_{\text{EN(lo)}}$			1.0	V
Pin PWM_D input high voltage	$V_{\text{IN}} = 15\text{-}500\text{V}$	$V_{\text{EN(hi)}}$	2.4			V
Pin PWM_D pull-down resistance	$V_{\text{EN}} = 5\text{V}$	R_{EN}	50	100	150	k Ω
Current sense pull-in threshold voltage	@ $T_A = -40^\circ\text{C}$ to $+85^\circ\text{C}$	$V_{\text{CS(hi)}}$	225	250	275	mV
GATE high output voltage	$I_{\text{OUT}} = 10\text{mA}$	$V_{\text{GATE(hi)}}$	V_{DD} -0.3		V_{DD}	V
GATE low output voltage	$I_{\text{OUT}} = -10\text{mA}$	$V_{\text{GATE(lo)}}$	0		0.3	V
Oscillator frequency	$R_{\text{OSC}} = 1.00\text{M}\Omega$	f_{OSC}	20	25	30	kHz
	$R_{\text{OSC}} = 226\text{k}\Omega$		80	100	120	
Maximum Oscillator PWM Duty Cycle	$F_{\text{PWMhf}} = 25\text{kHz}$, at GATE, CS to GND.	D_{MAXhf}			100	%
Linear Dimming pin voltage range	@ $T_A = <85^\circ\text{C}$, $V_{\text{in}} = 20\text{V}$	V_{LD}	0		$V_{\text{CS(hi)}}$	mV
Current sense blanking interval	$V_{\text{CS}} = 0.55V_{\text{LD}}$, $V_{\text{LD}} = V_{\text{DD}}$	T_{BLANK}	150	215	280	ns
Delay from CS trip to GATE lo	$V_{\text{in}} = 20\text{V}$, $V_{\text{LD}} = 0.15$, $V_{\text{CS}} = 0$ to 0.22V after T_{BLANK}	t_{DELAY}			300	ns
GATE output rise time	$C_{\text{GATE}} = 500\text{pF}$	t_{RISE}		30	50	ns
GATE output fall time	$C_{\text{GATE}} = 500\text{pF}$	t_{FALL}		30	50	ns
Thermal shut down		T_{SD}		150		$^\circ\text{C}$

PACKAGE DESCRIPTION Dimensions in inches (millimeters) unless otherwise specified

S08

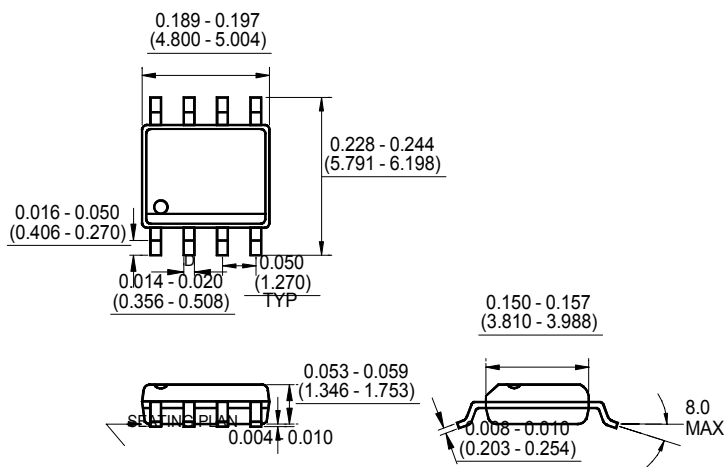

DIP 8

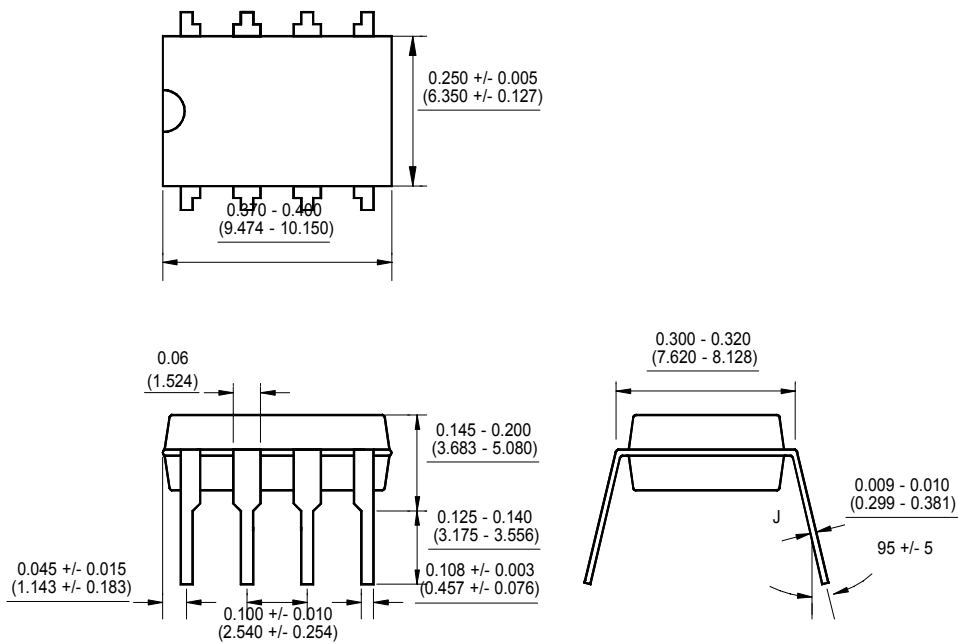

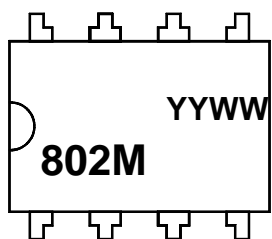
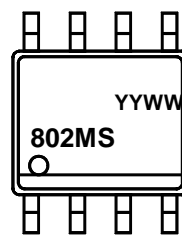
MARKING DIAGRAM**DIP 8****SO 8**

YY = Year, WW = Working Week