

High input voltage LDO Linear Regulators

Descriptions:

ME6201 series are low-dropout linear voltage regulators with a built-in voltage reference module, error correction module and phase compensation module. ME6201 series are based on the CMOS process and allow high voltage input with low quiescent current. This series has the function of internal feedback resistor setting from 3V to 5V. The output accuracy is $\pm 2.5\%$.

Features:

- High output accuracy: $\pm 2.5\%$
- Input voltage: up to 16V
- Output voltage: 3.0 V ~ 5.0V
- Ultra-low quiescent current (Typ. = 3 μ A)
- When $V_{in} = 5.3V$ and $V_{out} = 3.3V$ when $I_{out} = 100mA$
- Importation good stability: Typ. 0.1% / V
- Low temperature coefficient
- Ceramic capacitor can be used
- Package: SOT-89, TO-92

Selection Guide:

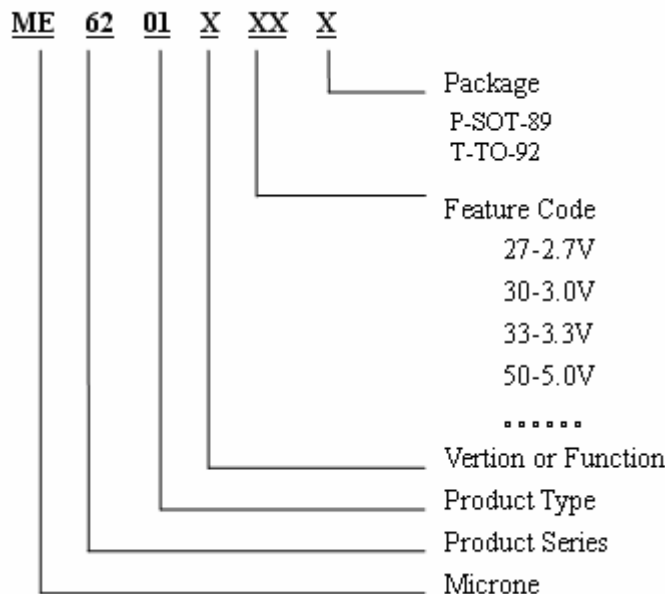

Applications:

- Electronic weighbridge
- SCM
- Phones, cordless phones
- Security Products
- Water meters, power meters

TYPE	POSTFIX	PACKAGE	CE FUNCTION	FEATURES
ME6201AXX	P	SOT-89	No	
	T	TO-92		

Pin Configuration:

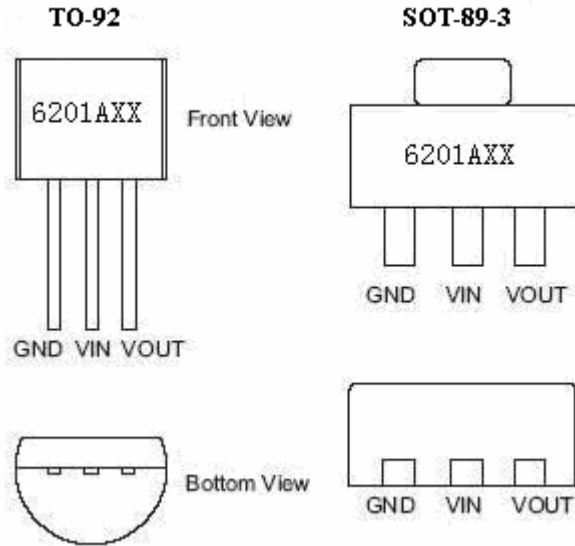

Pin Assignment:

ME6201AXX

PIN Number		PIN NAME	FUNCTION
SOT-89-3	TO-92		
1	1	Vss	Ground
2	2	Vin	input
3	3	Vout	Output

Block Diagram:

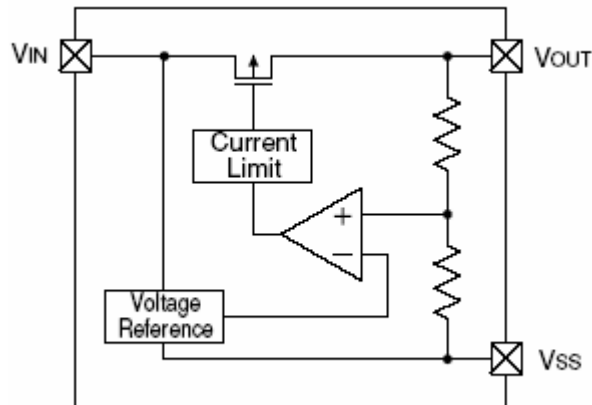

Absolute Maximum Ratings:

PARAMETER	SYMBOL	RATINGS	UNITS
Input Voltage	V_{IN}	18	V
Output Current	I_{out}	200	mA
Output Voltage	V_{out}	$V_{SS}-0.3 \sim V_{out}+0.3$	V
Power Dissipation	SOT-89	P_d	500
	TO-92	P_d	300
Operating Ambient Temperature	T_{Opr}	-25 ~ +85	°C
Storage Temperature	T_{stg}	-40 ~ +125	°C
Soldering Temperature And Time	T_{solder}	260°C, 10s	

Caution : The absolute maximum ratings are rated values exceeding which the product could suffer physical damage. These values must therefore not be exceeded under any conditions.

Electrical Characteristics:

ME6201A33 ($V_{in}=V_{out}+2V, C_{in}=C_{out}=10\mu, T_a=25^\circ C$ Unless otherwise stated)

PARAMETER	SYMBOL	CONDITION	MIX	TYP	MAX	UNITS
Output Voltage	$V_{OUT(E)}$ (Note 2)	$I_{OUT}=10mA,$ $V_{IN}=V_{out}+2V$	X 0.975	$V_{OUT(T)}$	X 1.025	V
Input Voltage	V_{IN}		3.3		16	V
Maximum Output Current	$I_{OUT(max)}$	$V_{IN}=V_{out}+2V$		100 (Note4)		mA
Load Regulation	ΔV_{OUT}	$V_{IN}=V_{out}+2V,$ $1mA \leq I_{OUT} \leq 80mA$		40		mV
Dropout Voltage (Note 3)	V_{dif1}	$I_{OUT} = 10mA$		150		mV
	V_{dif2}	$I_{OUT} = 50mA$		700		mV
Supply Current	I_{SS}	$V_{IN}=V_{out}+2V$		3		μA
Line Regulations	$\frac{\Delta V_{OUT}}{\Delta V_{IN} \cdot V_{OUT}}$	$I_{OUT} = 30mA$ $V_{out}+2V \leq V_{IN} \leq 16V$		0.1		%/V

ME6201A50 ($V_{in}=V_{out}+2V, C_{in}=C_{out}=10\mu, T_a=25^{\circ}C$ Unless otherwise stated)

PARAMETER	SYMBOL	CONDITION	MIX	TYP	MAX	UNITS
Output Voltage	$V_{OUT(E)}$ (Note 2)	$I_{OUT}=10mA,$ $V_{IN}=V_{out}+2V$	X 0.975	$V_{OUT(T)}$	X 1.025	V
Input Voltage	V_{IN}		5.0		16	V
Maximum Output Current	$I_{OUT(max)}$	$V_{IN}=V_{out}+2V$		100 (Note4)		mA
Load Regulation	ΔV_{OUT}	$V_{IN}=V_{out}+2V,$ $1mA \leq I_{OUT} \leq 80mA$		60		mV
Dropout Voltage (Note 3)	V_{dif1}	$I_{OUT} = 10mA$		90		mV
	V_{dif2}	$I_{OUT} = 50mA$		500		mV
Supply Current	I_{SS}	$V_{IN}=V_{out}+2V$		4		μA
Line Regulations	$\frac{\Delta V_{OUT}}{\Delta V_{IN}} \cdot V_{OUT}$	$I_{OUT} = 30mA$ $V_{out}+2V \leq V_{IN} \leq 16V$		0.1		%/V

Note :

- $V_{OUT(T)}$: Specified Output Voltage
- $V_{OUT(E)}$: Effective Output Voltage (i.e. The output voltage when “ $V_{OUT(T)}+2.0V$ ”is provided at the V_{in} pin while maintaining a certain I_{out} value.)
- V_{dif} : $V_{IN1} - V_{OUT(E)}$
 V_{IN1} : The input voltage when $V_{OUT(E)}$ appears as input voltage is gradually decreased.
 $V_{OUT(E)}$ = A voltage equal to 98% of the output voltage whenever an amply stabilized I_{out} { $V_{OUT(T)}+2.0V$ } is input.
- The output current can be at least this value.
 Due to restrictions on the package power dissipation, this value may not be satisfied. Attention should be paid to the power dissipation of the package when the output current is large.
 This specification is guaranteed by design.

Typical application circuit:

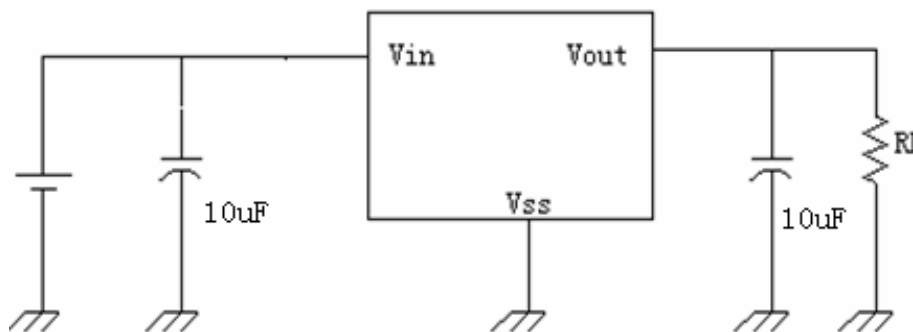

Caution The above connection diagram and constant will not guarantee successful operation. Perform thorough evaluation using the actual application to set the constant.

Application Conditions:

Input capacitor (CIN): 10.0 μ F or more

Output capacitor (CL): 10 μ F or more (tantalum capacitor)

- Precautions Wiring patterns for the VIN, VOUT and GND pins should be designed so that the impedance is low. When mounting an output capacitor between the VOUT and VSS pins (CL) and a capacitor for stabilizing the input between VIN and VSS pins (CIN), the distance from the capacitors to these pins should be as short as possible (less than 0.5cm).

Package Dimensions:

