

Timer
ZAW1 - Pulse-on release with 1 Changeover
 17.5mm housing



Application

Time control

Description

The **ZAW1 Pulse-on release timer** offers 16 different timing intervals in one unit. The timing intervals can be adjusted with DIP switches on the front panel of the relay. The timer can operate on either 230V AC using terminals A1 and A2 or 24V DC using terminals A3 and A2. The green LED indicates the connection to the power supply.

Function

Continuous presence of the power supply connected to the terminals A1 and A2 or A3 and A2 is required for timing. The activation of the timing function is accomplished with a potential-free control contact, which is connected to the terminals B1 and B2. When the power supply is applied, the control contact is opened, the output relay is energized and the timing is started. The output relay stays active for the set pulse time and is de-energized after this time has elapsed. The red LED indicates the working position of the control contact. If during or upon completion of the timing function the control contact is closed and reopened the timing period begins anew. This also applies if the supply is disconnected during the timing period.

Options

Other timing ranges and voltages available upon request.

Part number

011212 **ZAW1 Pulse-on release**
 16 Timing ranges / 1 Changeover

Timing ranges

16 timing ranges with adjustable DIP switches

0.05 – 1 s	0.5 – 10 min
0.15 – 3 s	1.5 – 30 min
0.5 – 10 s	3 – 60 min
1.5 – 30 s	15 – 300 min
3 – 60 s	0.5 – 10 h
5 – 100 s	1.5 – 30 h
10 – 200 s	3 – 60 h
15 – 300 s	5 – 100 h

DIP switch adjustments

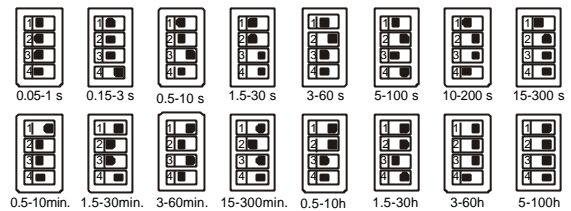

Approvals



Function diagram

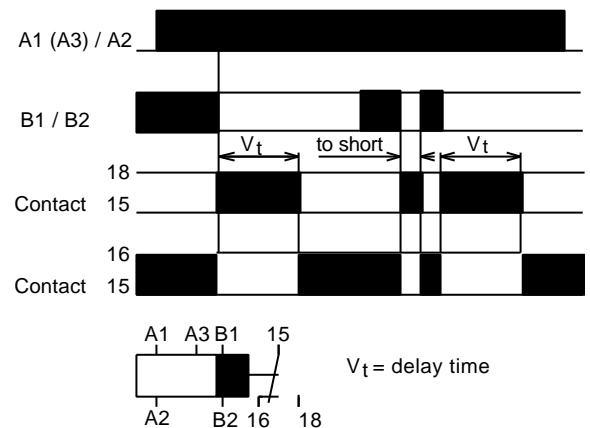

Mounting

Snap-on mounting using a standard DIN rail EN 50022. The unit is designed to allow side-by-side mounting, with an ambient temperature of < 60°C.

Timer
ZAW1 - Pulse-on release with 1 Changeover
 17.5mm housing

Technical data

Supply

Supply voltage	A1/A2: 230V AC	-15 / +10%
	A3/A2: 24V AC/DC	-15 / +10%
Frequency range:	0 / 50 ... 60Hz	
Power consumption:	approx. 1.5W with DC	
	approx. 6VA with AC	
Operating mode:	continuous	
Supply voltage influence:	< 0.01% over voltage range	
Temperature influence:	< 0.01%/°C	
Recovery time:	< 100ms	
Repetitive accuracy:	± 0.2%	

Operation indicators

Supply voltage:	LED, green
Relay in working position:	LED, red

Contact

Number of changeovers:	1
Contact material:	AgSnO ₂
Maximum switching voltage:	250V AC
Maximum switching current:	4A
Drop-off time of switching element:	approx. 20ms
Mechanical life:	30 Mio.
Electrical life (with rated load):	0.8 Mio.

General data

Ambient temperature:	- 25 ... + 60°C
Climate resistance:	VDE 0435T.2021
Mounting position:	any
Vibration resistance:	VDE 0435T.2021
Test voltage:	2.5kV
Isolation group:	VDE 0110 Group C 250
Protection class:	Terminals IP 20 Housing IP 40
Connection terminals:	Crosshead screws; M3.5 self-opening
Connection cross section:	Multi-strand wire with wire sleeves 2 x 2.5mm ² single-wire 2 x 2.5mm ²
Finger touch protection:	VDE 0106T.100 and VBG4
Mounting:	Symmetrical rail DIN EN 50022
Dimensions l x w x h:	90mm x 17.5mm x 69.5mm
Weight:	96g

Example

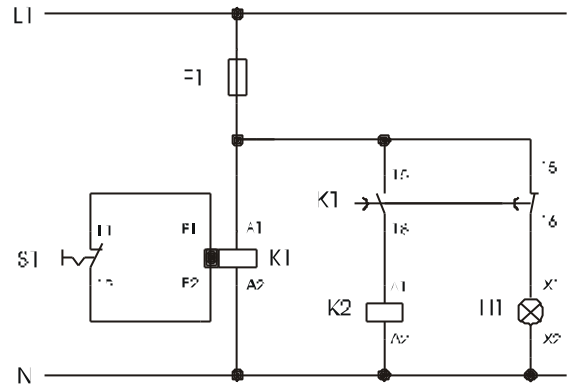

When the contact S1 opens, K2 energizes immediately and the light H1 goes off. After completion of the selected timing K2 returns to its rest position and the light H1 comes on.

Dimensions

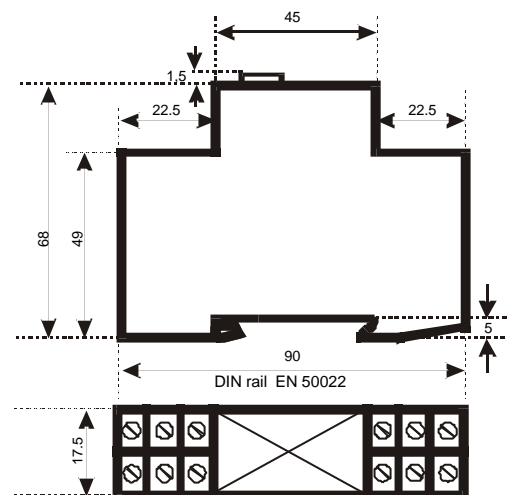

Connections

The terminal assignment for the connections is located on the front panel of the relay. **Reading the front panel from top to bottom**, the connections are in the following order:

LED side	Right:	B1 – nc – A3
	Left:	nc – nc – A1
Potentiometer side	Right:	B2 – 15 – 18
	Left:	nc – A2 – 16

上海悦中电气设备有限公司
 上海恒通路360号一天下大厦24C
 TEL: 021-62246890
 FAX: 021-52240873
 Http://www.skjd.cn
 E-mail: shskjd@126.com

