

Step-up PWM DC/DC Converter

❖ GENERAL DESCRIPTION

The AX5203 is high efficient step-up DC/DC converter. Large output current is possible having a built in internal N channel MOSFET, and using an external coil and diode.

The AX5203 can be operated at switching frequencies of 500 kHz allowing for easy filtering and low noise, the size of the external components can be reduced.

Output voltage is programmable with 1.0V of standard voltage supply internal, and using externally connected components, output voltage (FB) can be set up at will. The soft-start time can be programmed by outside capacitor; the function prevents overshoot at startup. Build inside Current limit, Thermal Shutdown and enable functions.

❖ FEATURES

- Input voltage : 4.5V to 23V
- Output voltage : 5 V to 68V
- Duty ratio : 0% to 85% PWM control
- Oscillation frequency : 500KHz.
- Enable and Thermal Shutdown function.
- Internal Current limit.
- Built-in N-channel MOSFET
- SOP-8L with Exposed pad Pb-Free package.

❖ BLOCK DIAGRAM

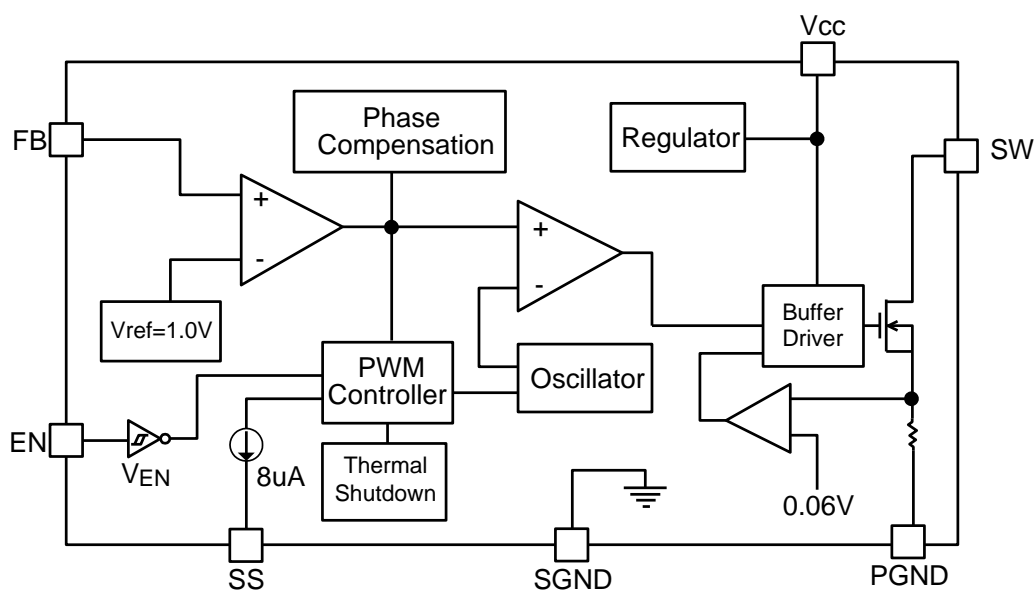

❖ PIN ASSIGNMENT

The package of AX5203 is SOP-8L-EP; the pin assignment is given by:

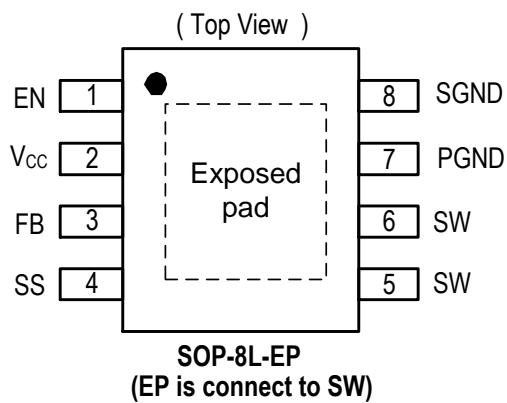

Name	Description
SGND	Signal Ground pin.
PGND	Power Ground pin
EN	Power-off pin H : normal operation(Step-up) L : Step-up operation stopped
Vcc	IC power supply pin
FB	Feedback pin
SW	Switch pin. Connect external inductor & diode here.
SS	Soft-Start Pin.

❖ ORDER/MARKING INFORMATION

Order Information	Top Marking
<p>AX5203 XX X</p> <p>Package Type ES: SOP-8L-EP</p> <p>Packing Blank : Tube A : Taping</p>	<p>Logo ← AX 5 2 0 3 → Part number</p> <p>Y Y W W X → ID code:internal</p> <p>WW: 01~52</p> <p>Year: 10=2010 11=2011</p>

❖ ABSOLUTE MAXIMUM RATINGS (at T_A=25°C)

Characteristics	Symbol	Rating	Unit
VCC Pin Voltage	V _{CC}	GND - 0.3 to GND + 25	V
Feedback Pin Voltage	V _{FB}	GND - 0.3 to 6	V
ON/OFF Pin Voltage	V _{EN}	GND - 0.3 to V _{CC}	V
Switch Pin Voltage	V _{SW}	GND - 0.3 to 70	V
SS Pin Voltage	V _{SS}	GND - 0.3 to 6	V
Power Dissipation	PD	Internally limited	mW
Storage Temperature Range	T _{ST}	-40 to +150	°C
Operating Junction Temperature	T _{OPJ}	-20 to +125	°C
Thermal Resistance from Junction to case	θ _{JC}	15	°C/W
Thermal Resistance from Junction to ambient	θ _{JA}	40	°C/W

Note: θ_{JA} is measured with the PCB copper area of approximately 1 in²(Multi-layer).

❖ ELECTRICAL CHARACTERISTICS

($V_{CC} = 12V$, $V_{OUT}=24V$, $T_A=25^{\circ}C$, unless otherwise specified)

Characteristics	Symbol	Conditions	Min	Typ	Max	Units	
Operating Supply Voltage	V_{CC}		4.5	-	23	V	
Output Voltage Range	V_{OUT}		5	-	68	V	
Feedback Voltage	V_{FB}	$I_{OUT}=0.1A$	0.98	1.00	1.02	V	
Feedback Bias Current	I_{FB}	$I_{OUT}=0.1A$	-	0.1	0.5	μA	
Quiescent Current	I_{CCQ}	$V_{FB}=1.5V$ force driver off	-	4	6	mA	
Shutdown Supply Current	I_{SD}	$V_{EN} = 0V$	-	1	10	μA	
Oscillation Frequency	F_{OSC}	SW pin	400	500	600	KHz	
Line Regulation		$V_{CC} = 4.5 \sim 0.8 * V_{OUT}$	-	1	-	%	
Load Regulation		$I_{OUT}=50m \sim 0.6A$	-	0.5	-	%	
EN Pin Logic input threshold voltage	V_{SH}	High (regulator ON)	2.0	-	-	V	
	V_{SL}	Low (regulator OFF)	-	-	0.8		
EN Pin Input Current	I_{SH}	$V_{EN}=2.5V$ (ON)	-	20	-	μA	
	I_{SL}	$V_{EN}=0.3V$ (OFF)	-	-1	-	μA	
SS pin Current	I_{SS}		-	8	-	μA	
Switching Current Limit	I_{LIM-SW}		1.8	2.0	-	A	
Internal MOSFET $R_{DS(ON)}$	$R_{DS(ON)}$	$V_{CC}=5V$	-	140	160	m Ω	
		$V_{CC}=12V$	-	100	120		
Efficiency	EFFI	$V_{CC}=12V$ $V_{OUT}=24V$	$I_{OUT} = 0.5A$	-	92	-	%
Maximum Duty Cycle	DC_{MAX}	$V_{FB}=0V$	-	85	-	%	
Minimum Duty Cycle	DC_{MIN}	$V_{FB}=1.5V$	-	0	-		
Thermal shutdown Temp	T_{SD}		-	145	-	$^{\circ}C$	

❖ APPLICATION CIRCUIT

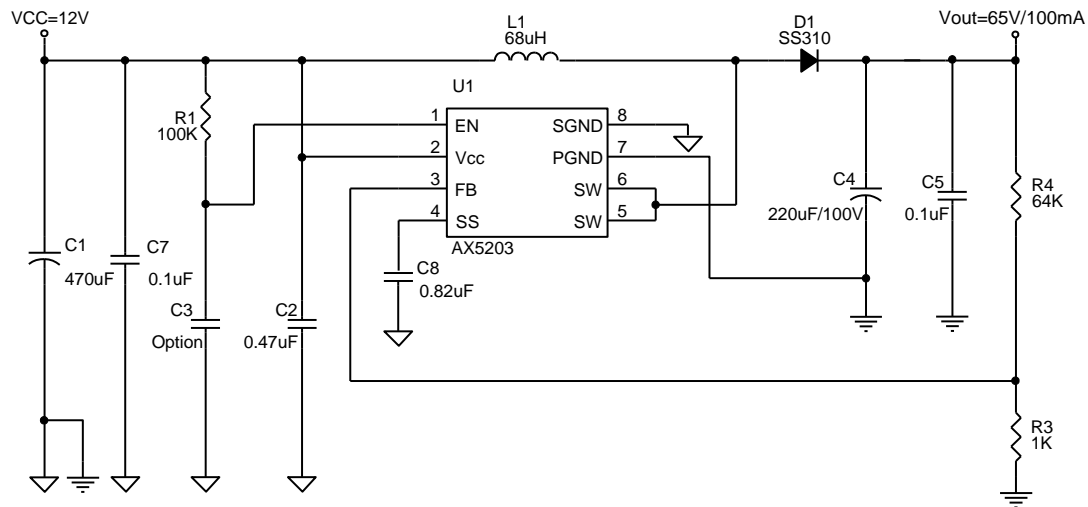

$$V_{OUT} = V_{FB} \times \left(1 + \frac{R4}{R3}\right), V_{FB} = 1.0V, R3 = 1K \sim 3K$$

❖ FUNCTION DESCRIPTIONS

PWM Control

The AX5203 consists of DC/DC converters that employ a pulse-width modulation (PWM) system. In converters of the AX5203, the pulse width varies in a range from 0 to 85%, according to the load current. The ripple voltage produced by the switching can easily be removed through a filter because the switching frequency remains constant. Therefore, these converters provide a low-ripple power over broad ranges of input voltage and load current.

Setting the Output Voltage

Application circuit item shows the basic application circuit with AX5203 adjustable output version. The external resistor sets the output voltage according to the following equation:

$$V_{out} = 1.0V \times \left(1 + \frac{R4}{R3}\right)$$

Table 1 Resistor select for output voltage setting

V _{OUT}	R3	R4
12V	1K	11K
18V	1K	17K
24V	1.3K	30K
40V	1K	39K
65V	1K	64K

Inductor Selection

For most designs, Low inductance values are physically smaller but require faster switching, which results in some efficiency loss. The inductor value can be derived from the following equation:

$$L = \frac{V_{IN} \times (V_{OUT} - V_{IN})}{V_{OUT} \times \Delta I_L \times f_{LX}}$$

Where is inductor Ripple Current. Large value inductors lower ripple current and small value inductors result in high ripple currents. Choose inductor ripple current approximately 15% of the maximum input current 1.6A, $\Delta I_L=0.24A$.

Table 2 Inductor select for output voltage setting (V_{CC}=12V)

V _{OUT}	18V	24V	40V	65V
L1 Value	33uH	47uH	68uH	82uH

The DC current rating of the inductor should be at least equal to the maximum load current plus half the ripple current to prevent core saturation (1.6A+0.12A).

Input Capacitor Selection

The input capacitor reduces the surge current drawn from the input and switching noise from the device. The input capacitor impedance at the switching frequency shall be less than input source impedance to prevent high frequency switching current passing to the input. A low ESR input capacitor sized for maximum RMS current must be used.

The capacitor voltage rating should be at least 1.5 times greater than the input voltage, and often much higher voltage ratings are needed to satisfy.

Output Capacitor Selection

The output capacitor is required to keep the output voltage ripple small and to ensure regulation loop stability. The output capacitor must have low impedance at the switching frequency. A low ESR capacitor sized for maximum RMS current must be used. The low ESR requirements needed for low output ripple voltage.

The capacitor voltage rating should be at least 1.5 times greater than the input voltage, and often much higher voltage ratings are needed to satisfy.

Output Voltage Ripple

Application circuit item shows the basic application circuit with AX5203. The output voltage ripple (V_{RIPPLE}) very larger at high switch current ($I_{SW}=3A$, $V_{RIPPLE} \approx 0.7V$), external π filters can reduce output voltage ripple.

π filters

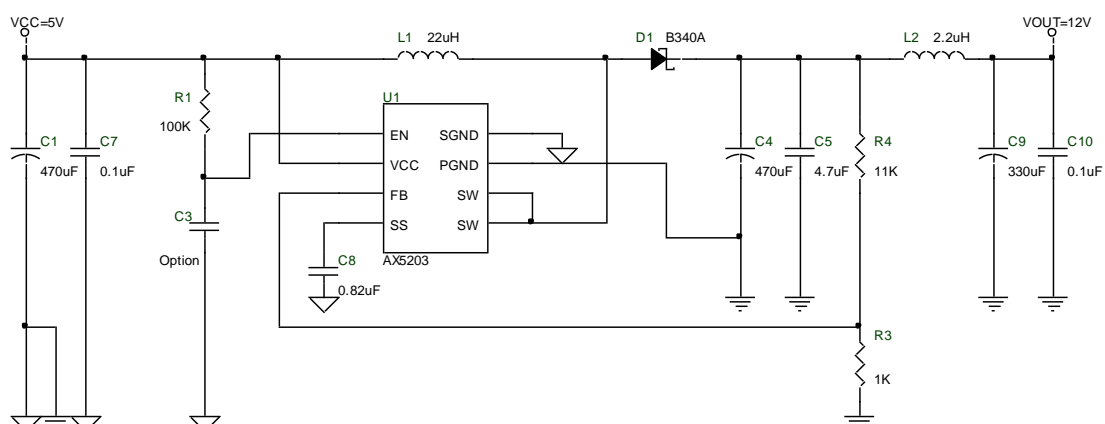

Layout Guidance (please refer layout picture)

When laying out the PC board, the following suggestions should be taken to ensure proper operation of the AX5203. These items are also illustrated graphically in below.

1. The power traces, including the Source trace, the Schottky and the C1 trace should be kept short, direct and wide to allow large current flow.
2. The power ground is keep C4's ground closed and far away signal ground.
3. The signal ground trace is distant from power ground trace.
4. The exposed pad is connecting to SW trace closely and widely. (Reduce IC temperature)
5. Do not trace signal line under inductor.

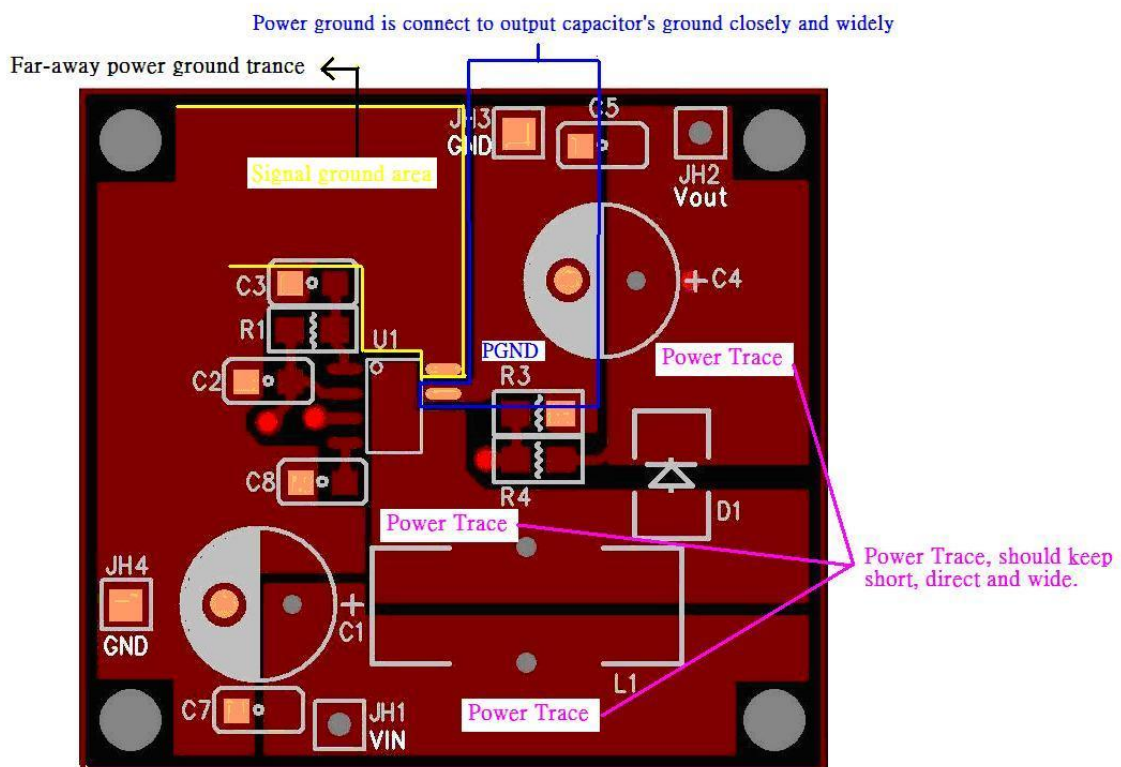

(AX5203 PCB Layout -Top View)

❖ PACKAGE OUTLINES

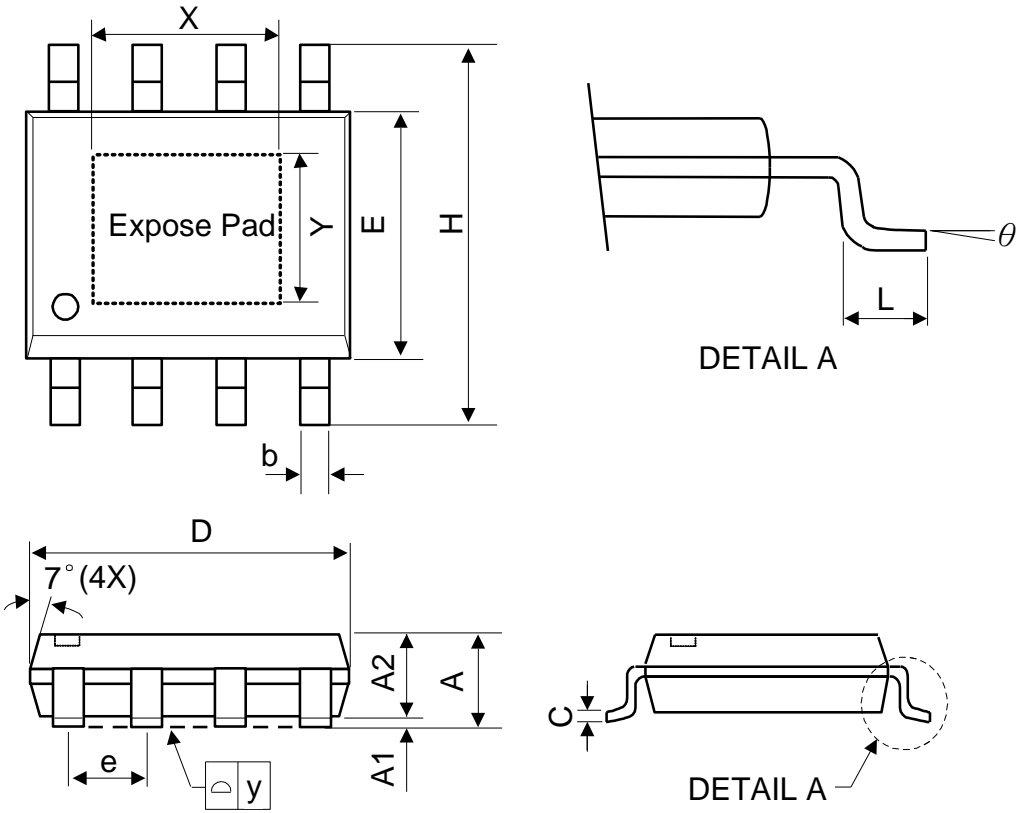

Symbol	Dimensions in Millimeters			Dimensions in Inches		
	Min.	Nom.	Max.	Min.	Nom.	Max.
A	-	-	1.75	-	-	0.069
A1	0	-	0.15	0	-	0.06
A2	1.25	-	-	0.049	-	-
C	0.1	0.2	0.25	0.0075	0.008	0.01
D	4.7	4.9	5.1	0.185	0.193	0.2
E	3.7	3.9	4.1	0.146	0.154	0.161
H	5.8	6	6.2	0.228	0.236	0.244
L	0.4	-	1.27	0.015	-	0.05
b	0.31	0.41	0.51	0.012	0.016	0.02
e	1.27 BSC			0.050 BSC		
y	-	-	0.1	-	-	0.004
X	-	2.34	-	-	0.092	-
Y	-	2.34	-	-	0.092	-
θ	0°	-	8°	0°	-	8°

Mold flash shall not exceed 0.25mm per side
JEDEC outline: MS-012 BA