

Ultrasonic level transmitter, non-contact



- Compact, remote versions for level measurement up to 10 m
- Multi language menu control
- Interference echo filter
- Automatic calibration: TEACH-IN
- Extensive additional functions (simulation, programmable tank shapes)

Type 8175 can be combined with...



Type 6213

Solenoid valve



Type 2030

Diaphragm valve



Type 2712 (8630)

Continuous
TopControl system

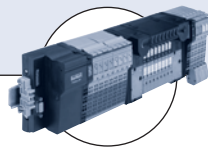

Type 8644

Valve islands

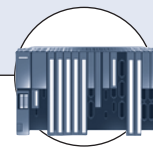

PLC

The Type 8175 is a non-contact filling level transmitter, designed for liquid level or volume measurement in open or closed vessels. The unit is also suitable for limited use with solids (depending on angle). The unit with the 2 relay option makes it possible to provide alarm messages and to automatically carry out filling and draining procedures.

The device is available in different models:

- Compact transmitter with integrated ultrasonic sensor.
- Remote transmitter, for panel- or wall mounting, for connection to the Bürkert 8170 sensor.

General data	
Materials	
Housing, cover	PC (compact and panel-mounted version); ABS (wall-mounted version)
Front panel foil	Polyester
Screws	Stainless steel
Cable plug / gland	PA
Probe	PVDF / POM (8170 probe cover)
Seal	none (in option: FKM or EPDM)
Display	15 x 60 mm, 8-digit LCD, alphanumeric, 15 segments, 9 mm high
Protection	Lockable switch for the "ENTER" key
Process connection	Mounting thread G 2" or NPT 2"
Electrical connections	Cable plug EN175301-803 or glands ¹⁾
Connection cable	Shielded cable; 1.5mm ² max. cross-section

Environment	
Ambient temperature	
Compact and probe 8170	-20 up to +60°C (operation and storage)
Panel- and Wall-mounted	-40 up to +80°C (operation and storage)
Relative humidity	≤ 80 %; non condensed

¹⁾ M16 x 1.5 cable gland for cable with ø 4-8 mm (wall-mounted version)

M20 x 1.5 cable gland for cable with ø 6-12 mm (compact version)

²⁾ Under reference conditions i.e. measuring fluid=liquid without foam, ambient and water temperature=20°C, ambient pressure value=atmospheric pressure

* F.S.=Full scale

Complete device data (compact or remote with 8170 probe versions)	
Measuring type	Level, distance (cm, m, inch or foot) or volume measurement (l, m ³ , US-Gal or Imp-Gal)
Measuring range²⁾	0.3 to 10 m (Compact version) 0.3 to 7 m (Panel- and Wall- mounted version)
Fluid temperature	-40 up to 80°C
Pressure range max.	2 bar at 25°C
Temperature adjustment	Programmable depending on gas medium
Accuracy	
Standard calibration	≤ ±0.25% of F.S.*
Teach-In calibration	≤ ±0.15% of F.S.*
Resolution	± 3 mm
Emission frequency	50 kHz
Fill beam width	8 degrees conical
Pulse rate	8 pulses per second
Blocking distance	30 cm from transducer base

Standards and approvals	
Protection class	IP65 (compact, panel- and wall-mounted version) IP20 (panel-mounted version, inside the cabinet) IP67 (Enclosure sensor)
Standard	
Emission	According to generic norm EN 50081-1
Immunity	According to generic norm EN 50082-2
Safety	According to safety regulations for measuring instruments for regulation and laboratory NF EN 61010-1

Electrical data	
Power supply	18-32 V DC (3-wire) filtered and regulated or 115/230 V AC 50/60 Hz ($\pm 10\%$)
Current consumption	≤ 200 mA
Output	
Standard signal	4-20 mA ($\pm 2\%$); 22 mA error signal; Invertible to 20-4 mA; Sinking or sourcing; max. loop impedance: 1300 Ω at 32 V DC; 1000 Ω at 24 V DC; 550 Ω at 18 V DC; 1100 Ω with a 115/230 V AC voltage supply
Relay (option)	2 relays, freely programmable, normally open 3A, 250 V DC/AC; 100000 cycles (minimum)
Fail safe	Power loss: Relay automatically inverts to the NO safe position in the event of signal or power loss. Signal loss: The relay takes the previously programmed safe position.

System versions

The compact version



combines an ultrasonic sensor and an electronic module (transducer) with a display in an IP65 enclosure.

The output signals are provided via a cable plug or via two cable glands.

The panel-mounted version



10 or 20 m cable



consists of electronic module 8175 integrated in a front-cover.

The associated separate level sensor is an 8170.

The output signals are provided on a terminal strip.

The wall-mounted version



10 or 20 m cable



consists of electronic module 8175 in an IP65 enclosure.

The associated separate level sensor is an 8170.

The output signals are provided on a terminal strip via cable glands.

Operation and display

The device can be calibrated by means of the TEACH-IN function. Customized adjustments, such as display of distance, level or volume, engineering units, filter, sound velocity are carried out on site.

The operation is specified according to three levels:

▶ Indication in operating mode / Display

- Level, distance or volume in the required engineering units (refer to calibration menu).
- Gas temperature (according to calibration menu).
- 4...20 mA output signal, proportional to the level, distance or volume according to the selected measuring range.

▶ Parameter definition -calibration mode

- Language (between English, German, French, Italian or Spanish).
- Engineering units for level, distance or volume.
- Damping selection and delay time setting for signal failure alarm. There are 10 steps available.
- Gas characteristics (velocity of sound and temperature influence)
- Selection of target level, if there are any fixed echos to be filtered and eliminated by the transmitter.
- Manual or automatic (TEACH-IN function) determination of reference measuring points.
- measuring range 4-20 mA
- Parameter definition of relays 1 & 2 for level, distance or volume, Temperature and/or failure alarm available
- Return to operation mode and storage of news parameters

▶ Test

- Offset adjustment (4 mA)
- Span adjustment (20 mA)
- Temperature adjustment
- Signal strength display
- Level, distance or volume simulation (dry-run test operation)
- Reset of interference table and return to factory settings

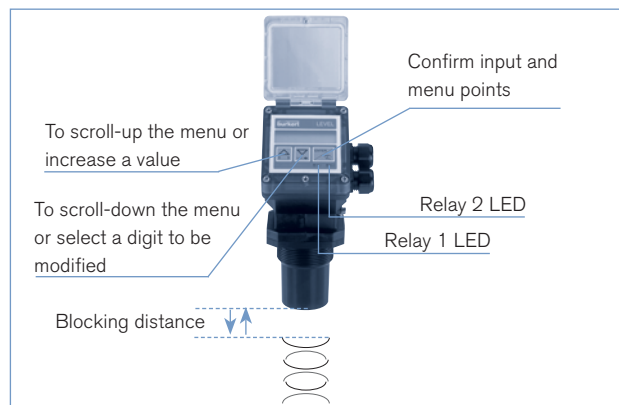

Principle of operation

A high frequency ultrasonic sound wave is pulsed eight times per second from the base of the transducer. This sound wave reflects against the process medium below and returns to the transducer. The microprocessor measures the time of flight between the sound generation and receipt, translates this figure into the distance or volume between transmitter and process medium below.

Avoid use in applications with risk of foam formation, condensation on the cell... For more information, please contact your Bürkert supplier.

Target applications with Type 8175 (compact or remote version)

- Continuous level measuring for fluids and solids.
- ON/OFF level measuring for fluids and solids.
- Flow measurement in open channels.
- Distance measuring.

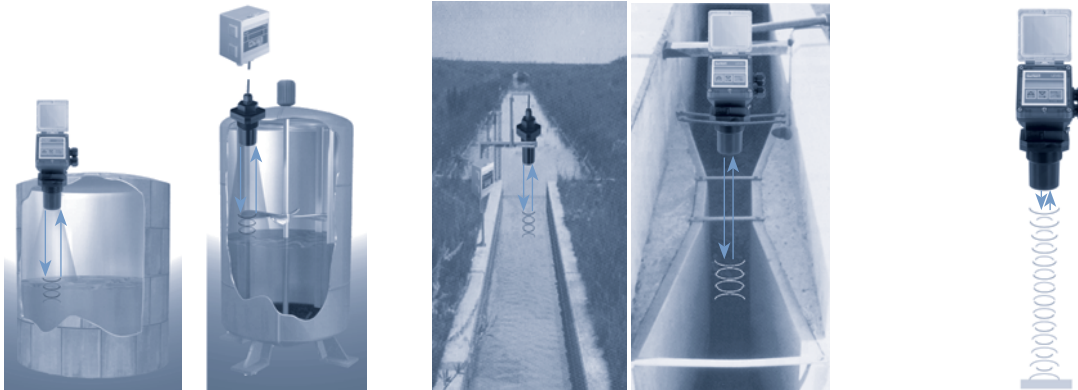

Echo filtering

In case of specific applications with many obstacles, the ultrasonic level transmitter Type 8175 (compact or remote version) can adapt itself after entering just one calibration value.

After this operation, all echoes of fixed and intermittent obstacles are stored and rejected. This allows the installation of the ultrasonic level transmitter Type 8175 (compact or remote version) even in applications with obstacles like mounting elements, blades, agitators, etc. in the beam cone.

Teach-In

The ultrasonic level transmitter Type 8175 (compact or remote version) allows the measurement of distance, level or volume, in different respective units.

In case of common tanks, entering the measures, for example the diameter of a cylindrical tank and a reference volume is enough to proceed to the volume measurements. In case of particular shapes, the ultrasonic level transmitter Type 8175 is able to be taught-in the shape, step-by-step, in an easy way.

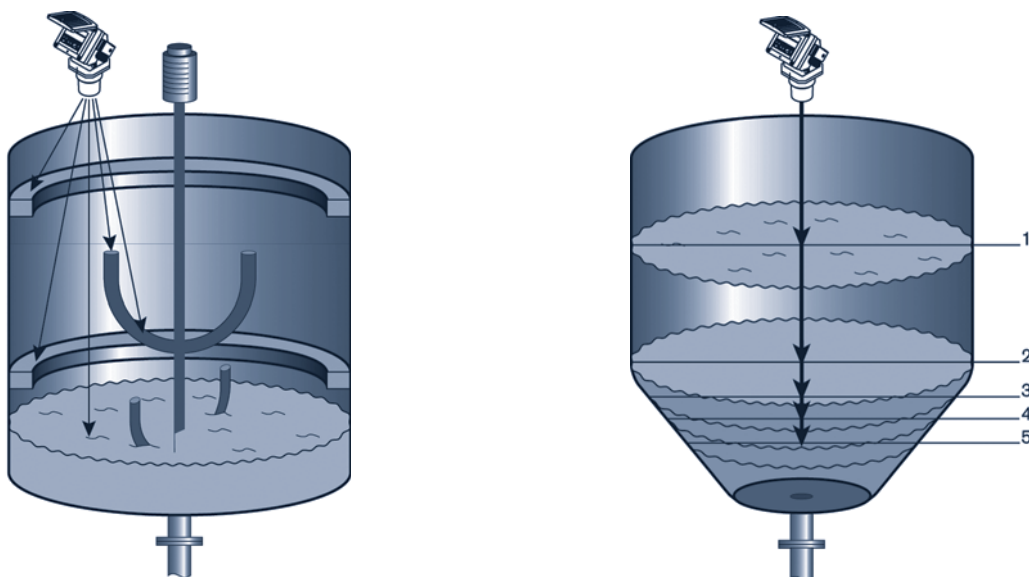

Dimensions [mm] compact version

with cable plug

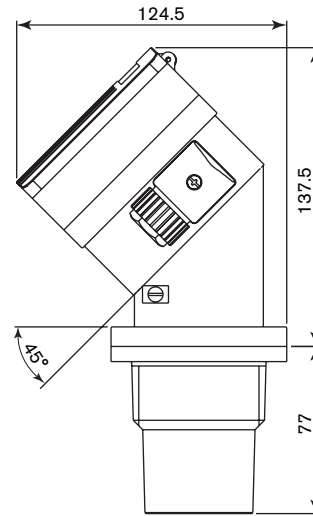
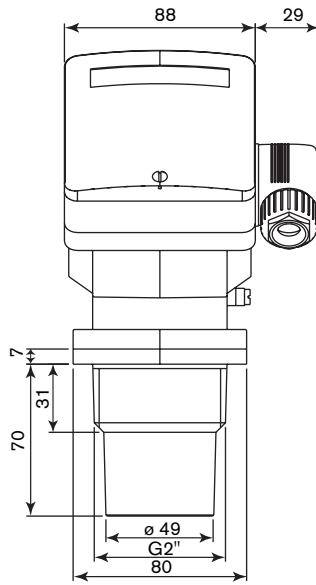

with cable gland

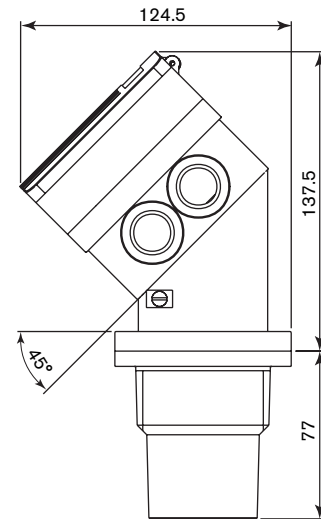
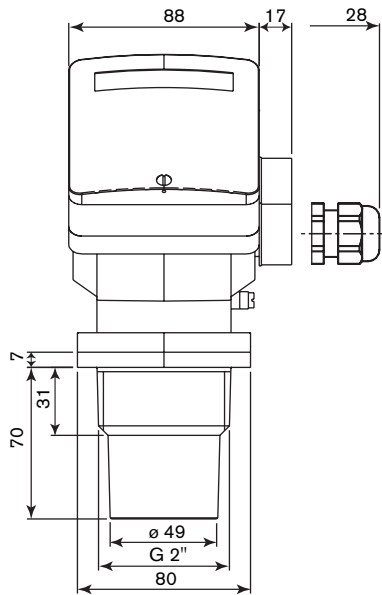

Dimensions [mm] remote version

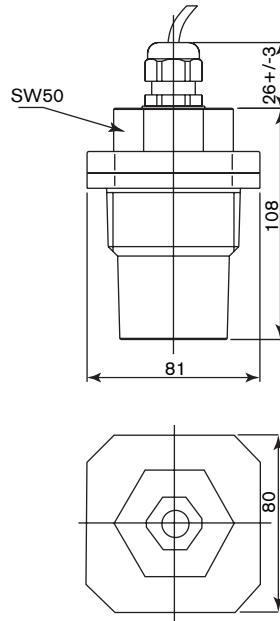

Remote ultrasonic probe 8170

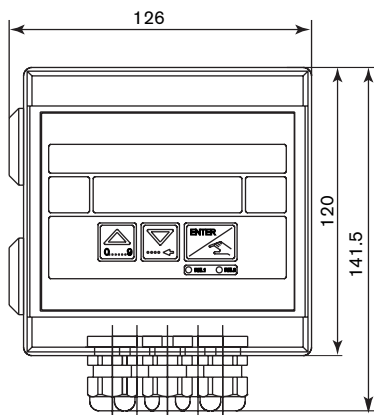
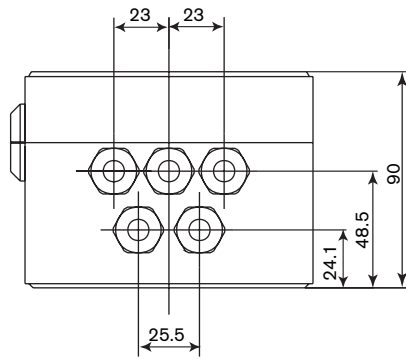

Wall-mounted version

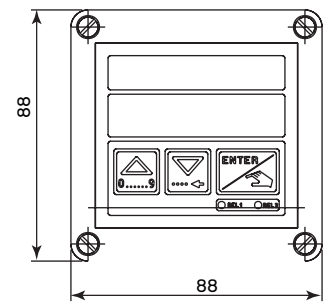
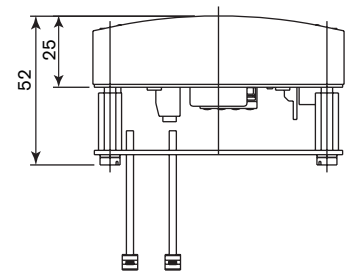

Panel-mounted version

Ordering chart for compact transmitter Type 8175

Specifications	Voltage supply	Output	Relays	Electrical connection	Item no.
G 2" mounting thread	18-32 V DC	4-20 mA (3 wires)	None	Cable plug EN 175301-803	430 822
			2	2 cable glands M20 x 1.5	430 823
			2	2 cable glands M20 x 1.5	430 824
	115-230 V AC	4-20 mA (2 wires)	None	2 cable glands M20 x 1.5	430 825
			2	2 cable glands M20 x 1.5	430 826
			2	2 cable glands M20 x 1.5	430 826
NPT 2" mounting thread	18-32 V DC	4-20 mA (3 wires)	None	Cable plug EN 175301-803	430 827
			2	2 NPT 1/2"	430 828
			2	2 NPT 1/2"	430 829
	115-230 V AC	4-20 mA (2 wires)	None	2 NPT 1/2"	430 830
			2	2 NPT 1/2"	430 831
			2	2 NPT 1/2"	430 831

Note: Cable gland M20 x 1.5 for cable with ø 6-12 mm

Ordering chart for remote transmitter Type 8175

Remote 8175 ultrasonic level transmitter (panel- or wall-mounted) for connection to Bürkert Type 8170 probe.

A complete remote ultrasonic level transmitter Type 8175 consists of:

- remote transmitter Type 8175 (wall-mounted or panel-mounted)
- Bürkert probe Type 8170 (has to be ordered separately)

Probe Type 8170

Specifications	Voltage supply	Connecting cable	Electrical connection	Item no.
G 2" mounting thread	-	cable, 10 m length	1 x M16 x 1.5	436 563
		cable, 20 m length	1 x M16 x 1.5	436 564
NPT 2" mounting thread	-	cable, 10 m length	1 x M16 x 1.5	436 565
		cable, 20 m length	1 x M16 x 1.5	436 566

Remote transmitter Type 8175 for probe Type 8170

Specifications	Voltage supply	Output	Relays	Electrical connection	Item no.
Panel-mounted version	18-32 V DC	4-20 mA (3 wires)	None	Terminal	436 567
			2	Terminal	436 568
Wall-mounted version	18-32 V DC	4-20 mA (3 wires)	None	5 cable glands M16 x 1.5	436 569
			2	5 cable glands M16 x 1.5	436 570
	115-230 V AC	4-20 mA (2 wires)	None	5 cable glands M16 x 1.5	437 339
			2	5 cable glands M16 x 1.5	437 340

Note: Cable gland M16 x 1.5 for cable with ø 4-8 mm

Ordering chart - accessories for transmitter Type 8175 (has to be ordered separately)

Specifications	Item no.
Set with 2 cable glands M20 x 1.5 + 2 neoprene flat seals for cable gland or plug + 2 screw-plugs M20 x 1.5 + 2 multiway seals 2 x 6 mm	449 755
Set with 2 reductions M20 x 1.5 / NPT1/2" + 2 neoprene flat seals for cable gland or plug + 2 screw-plugs M20 x 1.5	551 782
Set with 1 stopper for unused cable gland M 20 x 1.5 +1 multiway seal 2 x 6 mm for cable gland + 1 black EPDM gasket for the sensor + 1 mounting instruction sheet	551 775
PC - Nut	619 204
1 FKM gasket	448 818
1 EPDM gasket	448 819
Cable plug EN175301-803 with cable gland (Type 2508)	438 811
Cable plug EN175301-803 with NPT 1/2" reduction (Type 2509)	162 673
Mounting kit for the panel version	448 820

Interconnection possibilities with other Bürkert devices

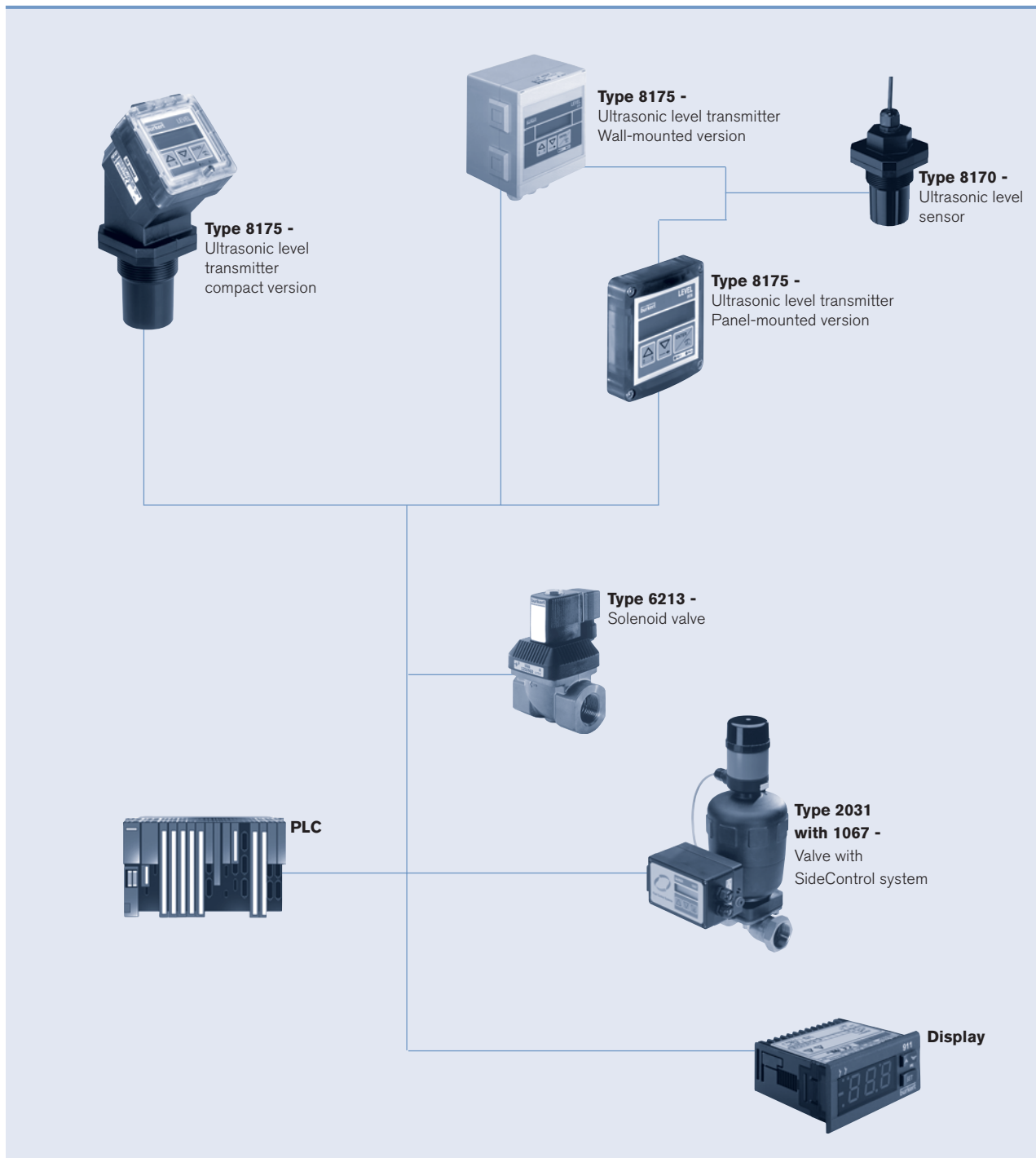

DTS 1000011100 EN Version: F Status: RL (released | freigegeben | validé) printed: 13.03.2007

To find your nearest Bürkert facility, click on the orange box →

www.burkert.com

In case of special application conditions, please consult for advice.

We reserve the right to make technical changes without notice.

0703/1_EU-en_00891797