



## FEATURES

- Independently regulated 5V/3.3V outputs
- 5V @ 3A/3.3V @ 4.25A simultaneously delivered
- Independent  $V_{OUT}$  Trim pins for margining
- Independent On/Off Control pins
- 88% efficiency; 75mV ripple/noise
- Input ranges: 10-18V, 18-36V or 36-75V
- UL 1950 and EN60950-1 safety approvals
- Fully isolated, 1500Vdc guaranteed
- Input under and overvoltage shutdown
- Independent OVP; short circuit protection
- Thermal shutdown

## PRODUCT OVERVIEW

Murata Power Solutions' BWR series of DC/DC converters now includes two independent converters in one 2" x 2" package. The BWR-5/3-3.3/4.25 family provides both 5V at 3 Amps and 3.3V at 4.25 Amps for a combined output power of 30 Watts from input ranges of 10V to 18V (-D12A), 18 to 36V (-D24A), or 36 to 75V (-D48A).

Each output is regulated by its own control loop to provide  $\pm 1\%$  load and  $\pm 0.5\%$  line regulation. Individual trim pins and a negative or positive on/off control pin allow independent adjustment of output voltages and any combination of power-on sequencing between the 5V and 3.3V outputs. A high efficiency of 88% allows full load operation

up to  $+65^{\circ}\text{C}$  ambient temperature in a still air environment. Although functionally independent, both outputs are driven from synchronized PWMs to prevent asynchronously generated beat frequencies.

Housed in a plastic case, all models include input Pi filtering, input overvoltage protection, independent output short circuit and current limiting protection and independent output overvoltage protection as well as thermal shutdown. These devices meet IEC950, UL1950 and EN6950-1 safety standards. CB reports are available upon request. "D48A" models are CE marked (meet LVD requirements).

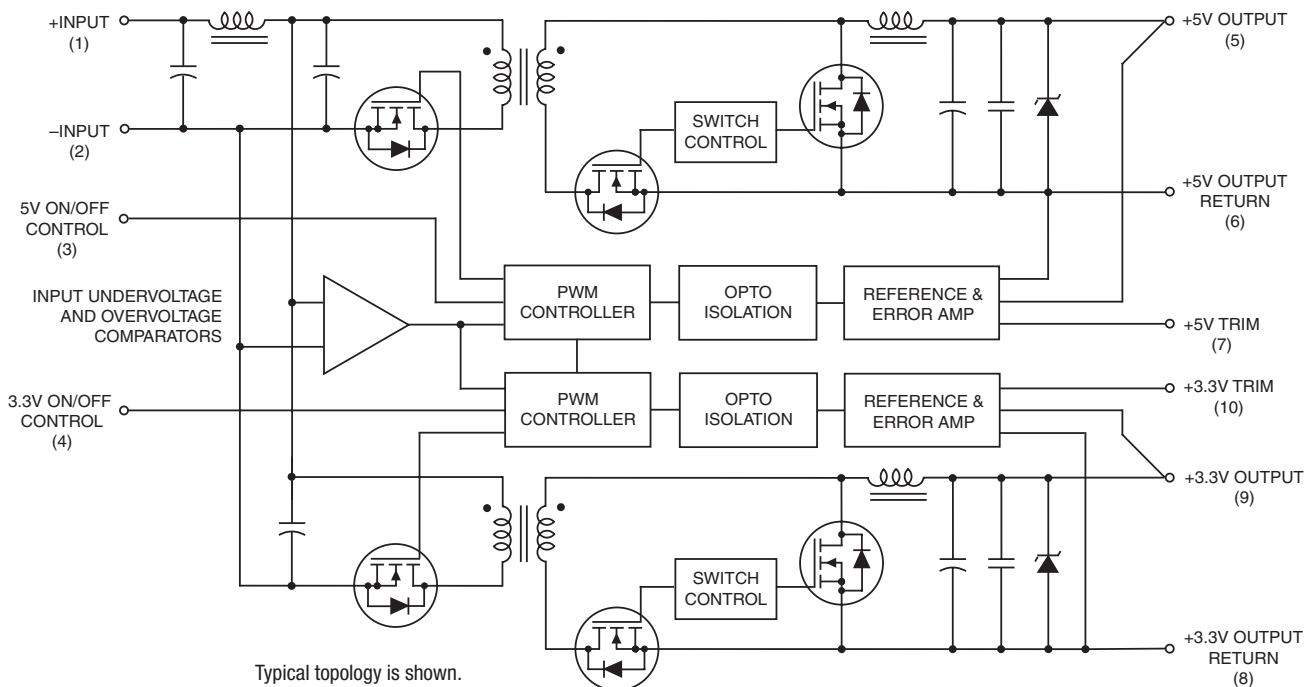

Figure 1. Simplified Schematic



## Performance Specifications and Ordering Guide <sup>①</sup>

Models <sup>⑥</sup>	Output						Input			Efficiency		Package (Case, Pinout)
	V <sub>OUT</sub> (Volts)	I <sub>OUT</sub> <sup>②</sup> (Amps)	R/N (mVp-p) <sup>③</sup>		Regulation (Max.)		V <sub>IN</sub> Nom. (Volts)	Range (Volts)	I <sub>IN</sub> <sup>⑤</sup> (mA/A)	Min.	Typ.	
			Typ.	Max.	Line	Load <sup>④</sup>						
BWR-5/3-3.3/4.25-D12A	5	3	75	100	±0.5%	±1%	12	10-18	210/2846	83%	85%	C20, P42
	3.3	4.25	75	100	±0.5%	±1%						
BWR-5/3-3.3/4.25-D24A	5	3	75	100	±0.5%	±1%	24	18-36	115/1374	85.5%	88%	C20, P42
	3.3	4.25	75	100	±0.5%	±1%						
BWR-5/3-3.3/4.25-D48A	5	3	75	100	±0.5%	±1%	48	36-75	70/687	85.5%	88%	C20, P42
	3.3	4.25	75	100	±0.5%	±1%						

- ① Typical at T<sub>A</sub> = +25°C under nominal line voltage and "full-load" conditions.
- ② Any combination of 5V/3.3V current, not to exceed the published I<sub>OUT</sub> specification (30 Watts).
- ③ Ripple/Noise (R/N) measured over a 20MHz bandwidth with 0.47µF ceramic output capacitors.
- ④ Tested from 10% load to 100% load.
- ⑤ Nominal line voltage, no load/full load condition.
- ⑥ These are incomplete model numbers. Please refer to the part number structure when ordering.

## PART NUMBER STRUCTURE

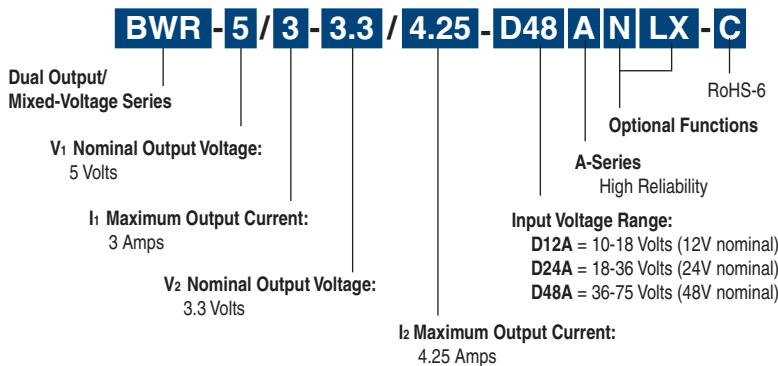

### Optional Functions

BWR 30 Watt DC/DC's are designed so a negative logic on/off control ("N" suffix) can be added in the pins 3 and 4 position.

- Blank**: Standard product. No options specified.
- N**: Negative polarity on/off control
- L1**: Pin length: 0.110 in. (2.79mm) ±0.010
- L2**: Pin length: 0.145 in. (3.68mm) ±0.010
- Y**: RoHS-5 Hazardous substance compliance
- C**: RoHS-6 Hazardous substance compliance

Refer to the last page for additional options.

**Note:** Not all model number combinations are available. Contact Murata Power Solutions (DATEL).

## MECHANICAL SPECIFICATIONS

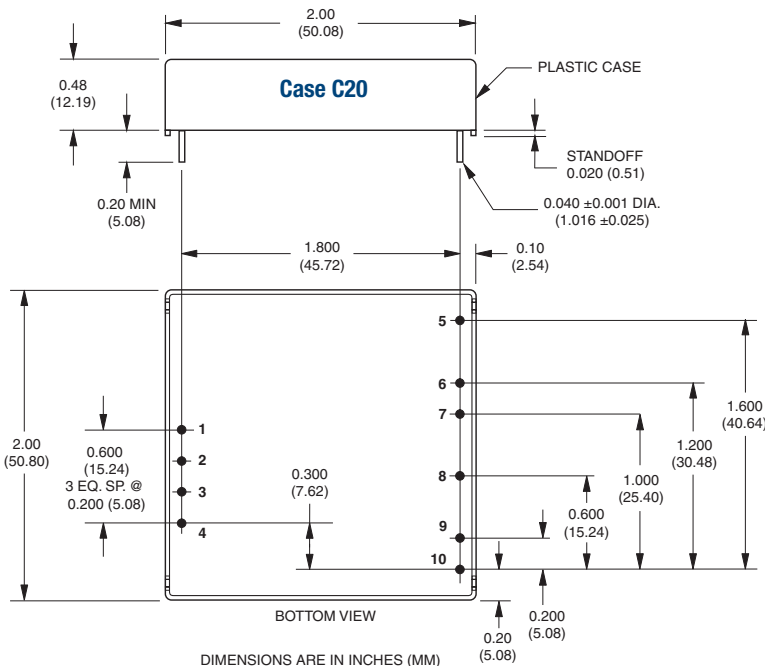

I/O Connections	
Pin	Function P42
1	+Input
2	-Input
3	+5V On/Off
4	+3.3V On/Off
5	+5V Output
6	+5V Return
7	+5V Trim
8	+3.3V Return
9	+3.3V Output
10	+3.3V Trim

### Performance/Functional Specifications

Typical @ T<sub>A</sub> = +25°C under nominal line voltage, balanced "full-load" conditions, unless noted. ①

Input	
<b>Input Voltage Range:</b>	
D12A Models	10-18 Volts (12V nominal)
D24A Models	18-36 Volts (24V nominal)
D48A Models	36-75 Volts (48V nominal)
<b>Overvoltage Shutdown:</b>	
D12A Models	18.5-21 Volts (20V nominal)
D24A Models	37-40 Volts (38V typical)
D48A Models	77-81 Volts (79V typical)
<b>Start-Up Threshold:</b>	
D12A Models	9.4-10 Volts (9.6V typical)
D24A Models	16.5-18 Volts (17V typical)
D48A Models	34-36 Volts (35V typical)
<b>Undervoltage Shutdown:</b>	
D12A Models	7-8.5 Volts (8V typical)
D24A Models	16-17.5 Volts (16.5V typical)
D48A Models	32.5-34.5 Volts (33.5V typical)
<b>Input Current:</b>	
Normal Operating Conditions	See Ordering Guide
Standby Mode: Off, OV, UV, Thermal Shutdown	10mA typical
<b>Input Reflected Ripple Current:</b>	
Source Impedance	<0.1Ω, no external input filtering
D12A Models	TBD
D24A/D48A Models	TBD
<b>Internal Input Filter Type</b>	Pi (0.022μF - 4.7μH - 2.46μF)
<b>Reverse-Polarity Protection:</b>	
D12A Models	1 minute duration, 6A maximum
D24A Models	1 minute duration, 4A maximum
D48A Models	1 minute duration, 2A maximum
<b>On/Off Control (Pins 3 &amp; 4):</b> ③ ⑤	
D12A, D24A & D48A Models	On = open or 13V to +V <sub>IN</sub> , I <sub>IN</sub> = 1.6mA @ 13V Off = 0-0.8V, I <sub>IN</sub> = 2mA @ 0V
"N" Suffix Models ⑥	On = 0-1.2V, I <sub>IN</sub> = 2mA @ 0V Off = open.
Output	
<b>V<sub>OUT</sub> Accuracy</b>	
5V Output	±1.5% maximum
3.3V Output	±1.5% maximum
<b>Minimum Loading Per Specification</b>	10% of I <sub>OUT</sub> maximum
<b>Minimum Loading For Stability</b> ⑦	No load
<b>Ripple/Noise (20MHz BW)</b> ④	See Ordering Guide
<b>Line/Load Regulation</b>	See Ordering Guide
<b>Efficiency</b>	See Ordering Guide
<b>Trim Range</b> ②	±5%
<b>Isolation Voltage:</b>	
Input-to-Output	1500Vdc minimum
<b>Isolation Resistance</b>	100MΩ
<b>Isolation Capacitance</b>	470pF
<b>Current Limit Inception:</b>	
5V @ 98.5% V <sub>OUT</sub>	3.8-5.1 Amps
3.3V @ 98.5% V <sub>OUT</sub>	5.4-6.8 Amps
<b>Short Circuit Current:</b>	
5V Output	3.0 Amps average current
3.3V Output	3.0 Amps average current

Output (continued)	
<b>Overvoltage Protection:</b>	Magnetic feedback, transorb
5V Output	6.0 Volts
3.3V Output	4.1 Volts
<b>Maximum Capacitive Loading</b>	
D12A Models 3.3V	1000μF
5V	680μF
D24A, D48A Models 3.3V	1000μF
5V	680μF
<b>Temperature Coefficient</b>	±0.02% per °C
Dynamic Characteristics	
<b>Dynamic Load Response:</b>	
5V (50-100% load step to 1% V <sub>OUT</sub> )	200μsec maximum
3.3V (50-100% load step to 1% V <sub>OUT</sub> )	200μsec maximum
<b>Start-Up Time:</b> ②	
V <sub>IN</sub> to V <sub>OUT</sub>	10ms
On/Off to V <sub>OUT</sub>	TBD
<b>Switching Frequency</b>	355kHz (±35kHz)
Environmental	
<b>MTBF</b> ⑥	Bellcore, ground fixed, full power 25°C ambient
D12A Models	873.9 thousand hours
D24A Models	1.32 million hours
D48A Models	1.23 million hours
<b>Operating Temperature (Ambient):</b> ②	
Without Derating:	
D12A Models	-40 to +60°C
D24A & D48A Models	-40 to +65°C
With Derating	To +100°C (See Derating Curves)
<b>Case Temperature:</b>	
Maximum Operational	+100°C
For Thermal Shutdown	+100°C minimum, +110°C maximum
<b>Storage Temperature</b>	-40 to +120°C
Physical	
<b>Dimensions</b>	2" x 2" x 0.5" (50.8 x 50.8 x 12.7mm)
<b>Case Material</b>	Diallyl phthalate, UL94V-0 rated
<b>Pin Material</b>	Gold-plated copper alloy
<b>Weight:</b>	2.7 ounces (76.5 grams)
<b>Primary to Secondary Insulation Level</b>	Operational

① All models are specified with external 0.47μF ceramic output capacitors.

② See Technical Notes/Graphs for details.

③ Applying a voltage to On/Off Control (pins 3 & 4) when no input power is applied to the converter can cause permanent damage.

④ Output noise may be further reduced with the installation of additional external output capacitors. See Technical Notes.

⑤ On/Off control is designed to be driven with open collector or by appropriate voltage levels. Voltages must be referenced to the -Input (pin 2).

⑥ Demonstrated MTBF available on request.

⑦ For conditions with less than minimum loading, outputs remain stable. However, regulation performance will degrade.

⑧ Maximum applied voltage to On/Off pin (N suffix) less than 19.0V.

## Mixed Voltage, 5V and 3.3V, Independent Dual Output 30 Watt DC/DC Converters

Absolute Maximum Ratings		
<b>Input Voltage:</b>		
Continuous:	D12A Models	23 Volts
	D24A Models	42 Volts
	D48A Models	81 Volts
Transient (100msec):	D12A Models	25 Volts
	D24A Models	50 Volts
	D48A Models	100 Volts
<b>Input Reverse-Polarity Protection</b>		
	Input Current must be limited. 1 minute duration. Fusing recommended.	
D12A Models	6 Amps	
D24A Models	4 Amps	
D48A Models	2 Amps	
<b>Output Current</b> ②		
	Current limited. Devices can withstand an indefinite output short circuit.	
<b>On/Off Control (Pins 3 &amp; 4) Max. Voltages</b>		
	Referenced to -Input (pin 2)	
D12A, D24A & D48A Models	+VIN	
"N" Models	±19V	
<b>Storage Temperature</b>		
	-40 to +120°C	
<b>Lead Temperature (Soldering, 10 sec.)</b>		
	+300°C	
These are stress ratings. Exposure of devices to any of these conditions may adversely affect long-term reliability. Proper operation under conditions other than those listed in the Performance/Functional Specifications Table is not implied, nor recommended.		

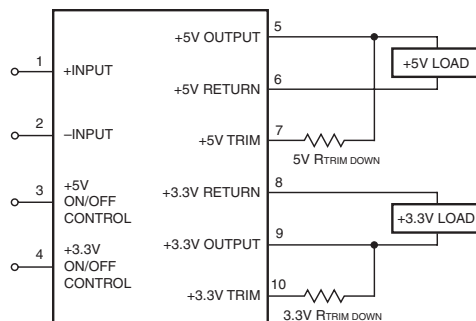

$$5V R_{T\_DOWN} (k\Omega) = \frac{2.49(V_O - 2.52)}{5 - V_O} - 15 \quad 3.3V R_{T\_DOWN} (k\Omega) = \frac{2.49(V_O - 1.27)}{3.3 - V_O} - 14.3$$

Figure 3. Trim Connections To Decrease Output Voltages Using Fixed Resistors

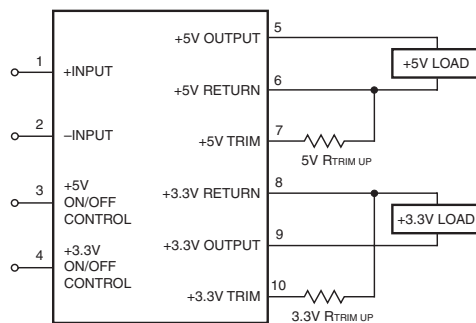

$$5V R_{T\_UP} (k\Omega) = \frac{6.27}{V_O - 5} - 15 \quad 3.3V R_{T\_UP} (k\Omega) = \frac{3.16}{V_O - 3.3} - 14.3$$

Figure 4. Trim Connections To Increase Output Voltages Using Fixed Resistors

Note: Resistor values are in kΩ. Accuracy of adjustment is subject to tolerances of resistors and factory-adjusted output accuracy.  
V<sub>O</sub> = desired output voltage.

### TECHNICAL NOTES

#### Trimming Output Voltages

These BWR converters have a trim capability (pins 3 & 4) that allow users to independently adjust the output voltages ±5%. Adjustments to the output voltages can be accomplished via a trim pot, Figure 2, or a single fixed resistor as shown in Figures 3 and 4. A single fixed resistor can increase or decrease the output voltage depending on its connection. Fixed resistors should have absolute TCR's less than 100ppm/°C to minimize sensitivity to changes in temperature.

A single resistor connected from the 5V Trim pin (pin 7) to the +5V Output (pin 5), see Figure 3, will decrease the +5V output voltage. A resistor connected from the +5V Trim (pin 7) to the +5V Return (pin 6) will increase the +5V output voltage. See Figure 4.

Similarly, the 3.3V output can be adjusted using a single resistor connected from the +3.3V Trim (pin 10) to the +3.3V Output (pin 9) or to the +3.3V Return (pin 8). See Figures 3 and 4.

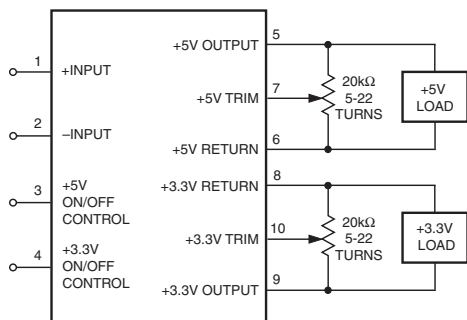
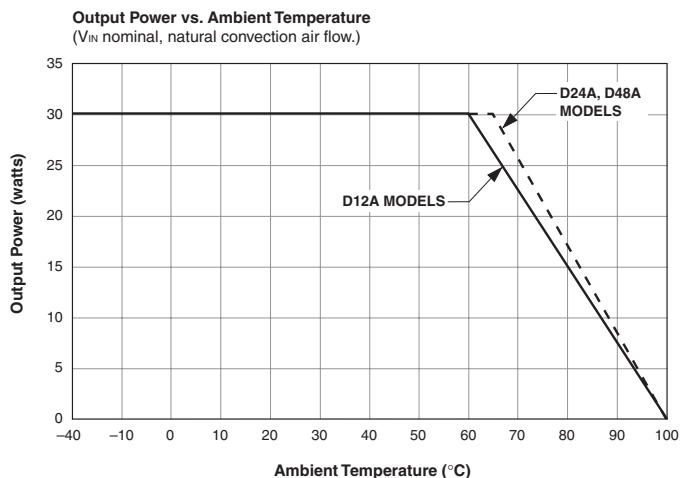

Figure 2. Trim Connections Using A Trim Pot

### Typical Performance Curves



## Typical Performance Curves

### Typical Start-Up from VIN

(VIN = nominal, 5V @ 3A/3.3V @ 4.25A, 0.47µF output capacitors.)

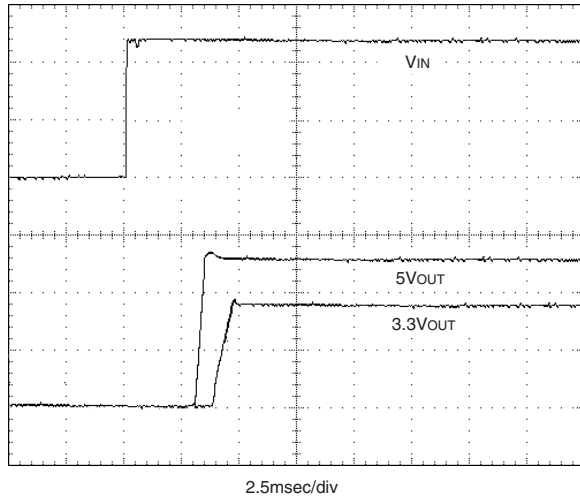

### D24A Models: Efficiency vs. Line and Load

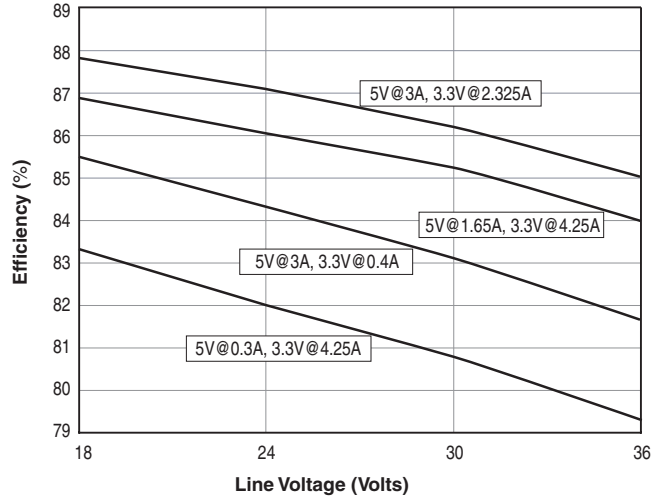

### D12A Models: Efficiency vs. Line and Load

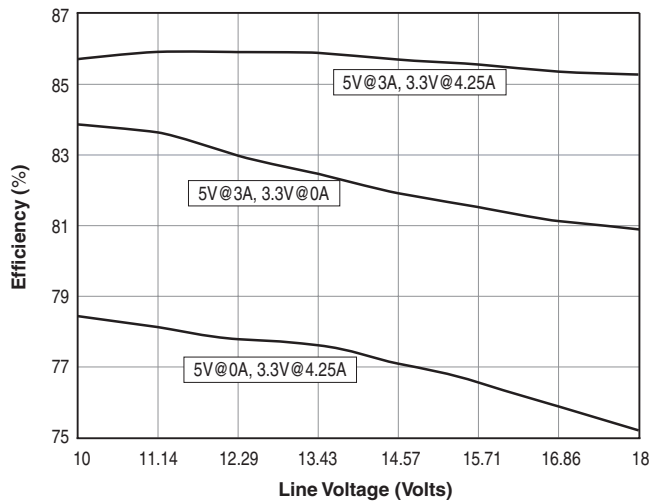

### D48A Models: Efficiency vs. Line and Load

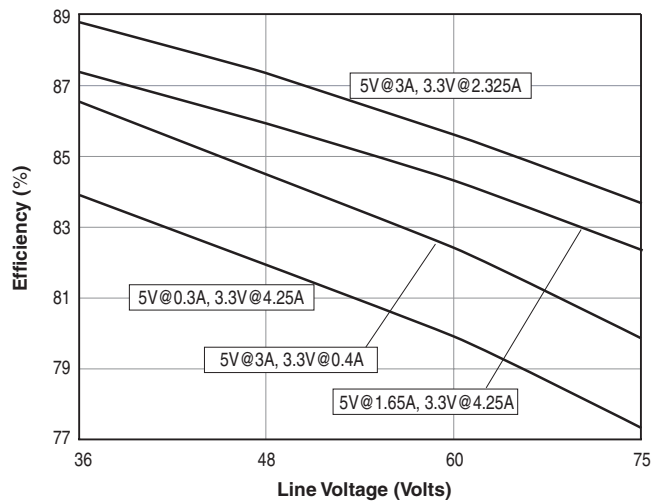

### Options and Adaptations

#### Optional Functions

The dual output BWR 30W DC/DC offer various electrical and mechanical options. Per the Ordering Guide on page 2, the trailing "A" (A-Series) in each part number pertains to the base part number. Part-number suffixes are added after the "A," indicating the selection of standard options. The resulting part number is a "standard product" and is available to any customer desiring that particular combination of options, as described below.

#### Suffix Description

- Blank** On/Off Control functions with positive polarity in pin 3 (5V) and pin 4 (3.3V) positions. The pin length remains at 0.2 inches (5.08 mm).
- N** On/Off Control function with negative polarity in pin 3 (5V) and pin 4 (3.3V) positions.
- L1** Trim the pin length to  $0.110 \pm 0.010$  inches ( $2.79 \pm 0.25$ mm). This option requires a 100-piece minimum order quantity.
- L2** Trim the pin length to  $0.145 \pm 0.010$  inches ( $3.68 \pm 0.25$ mm). This option requires a 100-piece minimum order quantity.

#### Adaptations

There are various additional configurations available on BWR 30W DC/DC's. Because designating each of them with a standard part-number suffix is not always feasible, such are designated by MPS in assigning a 5-digit "adaptation code" after the part-number suffixes. Once a configuration has been requested by a customer and created by MPS, the resulting product is available to any customer as a "standard" off-the-shelf product. Contact MPS directly if you are interested in your own set of options/adaptations. Our policy for minimum order quantities may apply.

Consequently, the following product is offered for sale:

BWR-5/3-3.3/4.25-D48A-30721

BWR-5/3-3.3/4.25-D48A-30721-Y (RoHS-5)

Standard product, 48VIN, 5V/3A and 3.3V/4.25A outputs with modified pinout C22A/P60 (competitor-compatible pin out), positive common On/Off logic for both outputs, modified Trim function for 3.3VOUT (no trim for 5VOUT) and Common return pin for both outputs. Trimmed pin length to 0.110 inches (2.8 mm).

RoHS-5 compliance refers to the exclusion of the six hazardous substances in the RoHS specification with the exception of lead. Murata Power Solutions' RoHS-5 products use all the conforming RoHS materials, however our solders may contain lead.

### MECHANICAL SPECIFICATIONS

