

LPT100-M Series

130 Watts

Total Power: 80 - 130 Watts
Input Voltage: 90 - 264 Vac
of Outputs: Triple

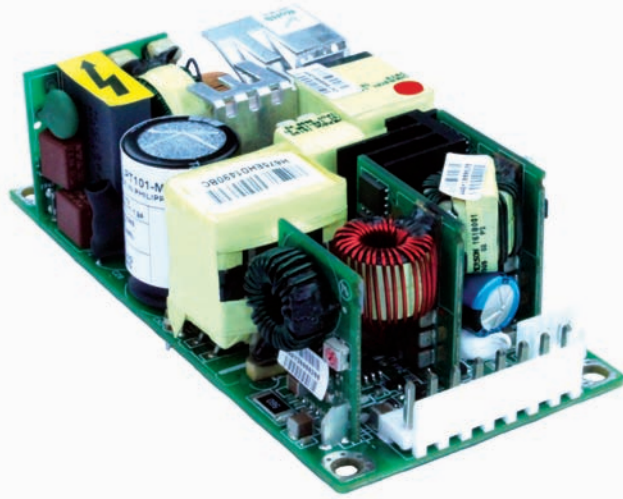

Special Features

- Medical and ITE safeties
- Active power factor correction
- 2" x 4" footprint
- Less than 1U high
- EN61000-3-2 compliant
- Remote sense
- Power fail
- Adjustable main output
- Built-in Class B EMI filter
- Overvoltage protection
- Overload protection
- Thermal overload protection
- LPX50 enclosure kit available

Electrical Specifications

Input	
Input range:	90 - 264 Vac; 127 - 300 Vdc
Frequency:	47 - 63 Hz
Inrush current:	50 A max., cold start @ 25 °C
Efficiency:	82% typical at full load
EMI/RFI:	FCC Class B conducted; CISPR22 Class B conducted; EN55022 Class B conducted; VDE0878PT3 Class B conducted
Safety ground leakage current:	275 μ A @ 50/60 Hz, 264 Vac input
Output	
Maximum power:	80 W for convection; 130 W with 200 LFM forced air
Adjustment range:	All outputs adjustable - 40%, +10%, except for +24V output on LPT104-xxx which will be -10%, +20%.
Hold-up time:	10 ms @ 130 W load, 120 Vac input
Overload protection:	Short circuit protection on all outputs. Case overload protected @ 110 - 160% above rating for V1 & V2, 110-190% for V3
Overvoltage protection:	15 - 35% above nominal output
Logical Control	
Power failure:	Active LowTTL logic signal goes high 100 - 500 msec after main output; it goes low at least 6 msec before loss of regulation
Remote sense:	Compensates for 0.5 V lead drop min. Will operate without remote sense connected. Reverse connection protected.

Safety

- TUV 60950, 60601-1
- UL 60950, 60601-1
- CSA 60950, 60601-1
- NEMKO 60950, 60601-1
- AUSTEL 60950, 60601-1
- CB Certificate & report
- CE Mark (LVD)

Environmental Specifications

Rev. 8.11.09_141
LPT100-M Series
2 of 3

Operating temperature:	0° to 50 °C ambient derate each output as 2.5% per degree from 50° to 70 °C. -20 °C start up
Storage temperature:	-40 °C to +85 °C
Electromagnetic susceptibility:	designed to meet EN61000-4; -2, -3, -4, -5, -6, -8, -11 Level 3
Humidity:	Operating; non-condensing 10% to 95% RH
Vibration:	IEC68-2-6 to the levels of IEC721-3-2
MTBF demonstrated	> 550,000 hours at full load and 25 °C ambient conditions

Mechanical Drawing

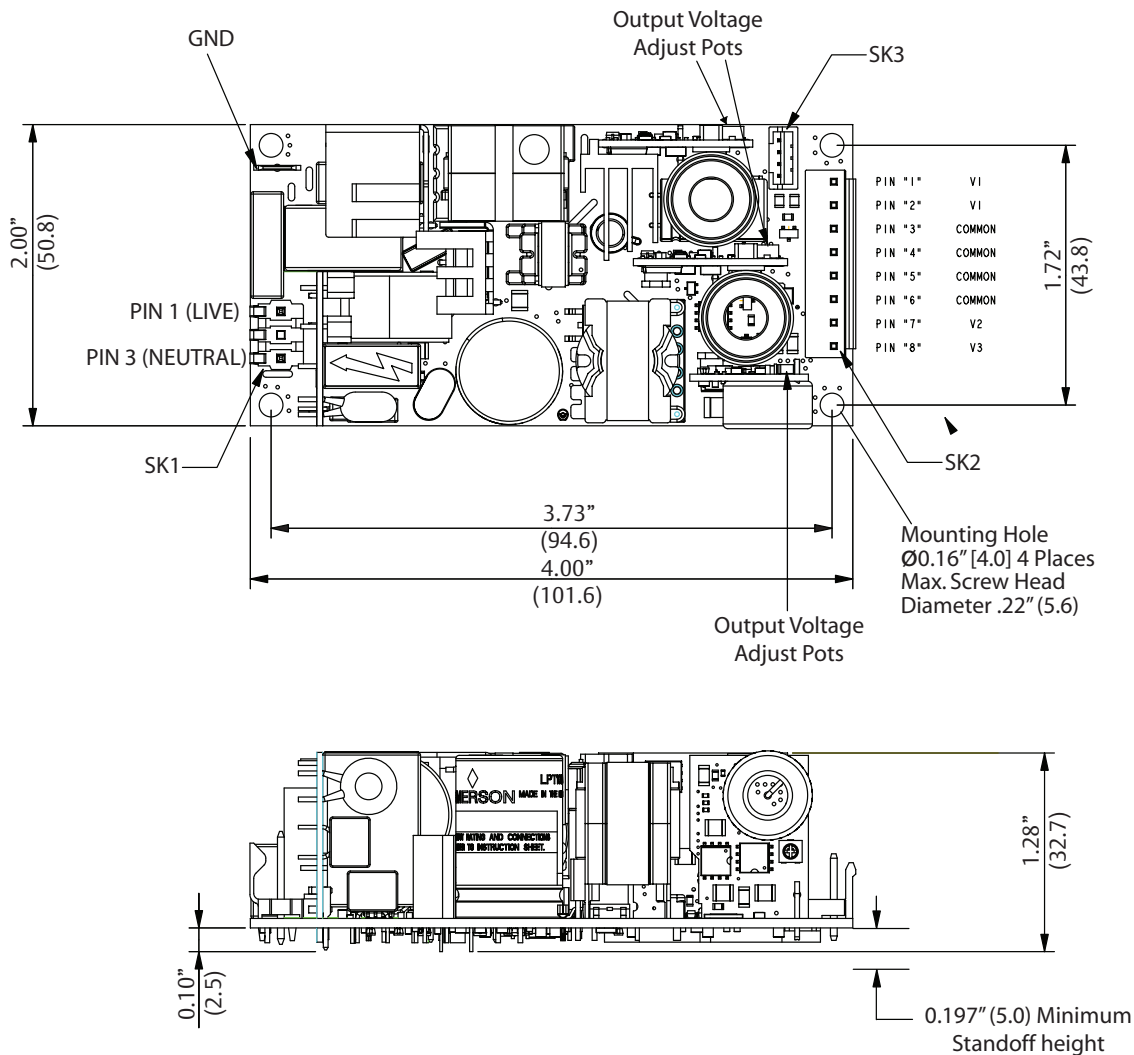

Ordering Information

Model Number	Output Voltage	Minimum Load	Maximum Load with Convection Cooling	Maximum Load with 30CFM Forced Air	Peak Load	Regulation ²	Ripple P/P (PAR) ³
LPT101-M	+3.3 V	0 A	13 A	18 A	20 A	±2%	50 mV
	+5 V	0 A	5 A	9 A	10 A	±5%	50 mV
	+12 V	0 A	1 A	2.3 A	2.3 A	±5%	120 mV
LPT102-M	+5 V	0 A	13 A	18 A	20 A	±2%	50 mV
	+12 V	0 A	5 A	9 A	10 A	±5%	120 mV
	-12 V	0 A	1 A	1.5 A	2 A	±5%	120 mV
LPT103-M	+5 V	0 A	13 A	18 A	20 A	±2%	50 mV
	+15 V	0 A	4 A	7.2 A	8 A	±5%	150 mV
	-15 V	0 A	1 A	1.5 A	2 A	±5%	150 mV
LPT104-M	+5 V	0 A	13 A	18 A	2 A	±2%	50 mV
	+24 V	0 A	1.5 A	3 A	3.5 A	±7%	240 mV
	+12 V	0 A	1 A	1.5 A	2 A	±5%	120 mV

1. Peak current lasting < 15 seconds with a maximum 10% duty cycle.
2. At 25 °C including initial tolerance, line voltage, load currents and output voltages adjusted to factory settings.
3. Peak-to-peak with 20 mHz bandwidth and 10 µF (tantalum capacitor) in parallel with a 0.1 µF capacitor at rated line voltage and load ranges.

Pin Assignments

Connector	LPT100-M	
SK1	PIN 1	Neutral
	PIN 3	Line
	PIN 2	V1out
SK2	PIN 1	V1out
	PIN 2	V1out
	PIN 3	GND
	PIN 4	GND
	PIN 5	GND
	PIN 6	GND
	PIN 7	V2out
	PIN 8	V3out
SK3	PIN 1	Power Fail
	PIN 2	GND
	PIN 3	+ Remote Sense
	PIN 4	- Remote Sense

Mating Connectors

AC Input (SK1):	Molex P/N 09-50-8031 PINS: 08-52-0113
AC Ground:	Molex P/N 01-9002001
DC Output (SK2):	JST P/N VHR-8N PINS: SVH-21T-P1.1
Remote Sense (SK3):	Molex P/N 87639-0400 PINS: 50212-8100
Emerson Network Power Connector Kit #70-841-026, includes all of the above	

Notes:

1. Specifications subject to change without notice.
2. All dimensions in inches (mm), tolerance is ±.02".
3. mounting holes MH1, MH2, MH3 should be grounded for EMI purpose
4. Mounting MH1 is safety ground connection
5. Specifications are for convection rating at factory settings at 115 Vac input 25 °C unless otherwise stated.
6. This power supply requires mounting on metal standoffs 0.20" (5 m) in height.
7. Warranty: 2 year
8. Weight: 0.44 lb. / 0.20 kg

Americas

5810 Van Allen Way
Carlsbad, CA 92008
USA
Telephone: +1 760 930 4600
Facsimile: +1 760 930 0698

Europe (UK)

Waterfront Business Park
Merry Hill, Dudley
West Midlands, DY5 1LX
United Kingdom
Telephone: +44 (0) 1384 842 211
Facsimile: +44 (0) 1384 843 355

Asia (HK)

14/F, Lu Plaza
2 Wing Yip Street
Kwun Tong, Kowloon
Hong Kong
Telephone: +852 2176 3333
Facsimile: +852 2176 3888

For global contact, visit:

www.PowerConversion.com
techsupport.embeddedpower@emerson.com

While every precaution has been taken to ensure accuracy and completeness in this literature, Emerson Network Power assumes no responsibility, and disclaims all liability for damages resulting from use of this information or for any errors or omissions.

Emerson Network Power.

The global leader in enabling business-critical continuity.

- AC Power
- Connectivity
- DC Power
- Embedded Computing
- **Embedded Power**
- Monitoring
- Outside Plant
- Power Switching & Controls
- Precision Cooling
- Racks & Integrated Cabinets
- Services
- Surge Protection

EmersonNetworkPower.com

Emerson Network Power and the Emerson Network Power logo are trademarks and service marks of Emerson Electric Co. ©2009 Emerson Electric Co.