

Designed for efficient termination of SSTL-2 (Series Stub Terminated Logic) signals in DDR (Dual Data Rate) memories, the DDR series non-isolated DC/DC converters are powered by the bus supply of 3 to 5.5 Volts and are compatible to industry-standard JEDEC JESD specifications for DDR memories.

### FEATURES

- For high performance termination of DDR computer memory busses
- Compatible to JEDEC JESD 79 and 8-9 DDR specifications
- Ideal for active wideband termination of SSTL-2 logic
- Non-isolated design with 1.25V typ. @ ±9 Amps output
- 3-5.5V input with 85% (typ.) efficiency
- Miniature industry standard 1.6 x 0.5 x 0.2 inch surface mount or SIP package
- Offers unique source/sink DDR requirements plus automatic reference tracking
- Retains controlled impedances and minimizes distortion of DDR digital data and double-side clocks
- Operates over -40 to +65°C with 200 lfm airflow
- Standard vertical mount, optional horizontal mount

### PRODUCT OVERVIEW

The DDR terminators are supplied in a 1.6 by 0.5 inch surface-mount or SIP package measuring only 0.2 inches high. Full output power (3.3V<sub>IN</sub>) is available up to +65°Celsius with only 200 LFM (linear feet per minute) of cooling airflow. No heat-sink is required.

Modern SSTL-2 logic uses reduced power voltages (typically 2.5 Volts), high switching currents and a relatively narrow voltage threshold window for logic switching. These factors contribute to the 266MHz data transfer rate. The V<sub>IT</sub> termination voltage output of the DDR operates approximately at the midpoint voltage of the bus (i.e., about 1.25V) and therefore will either source or sink current up to 9 Amps. To maintain a reliable window in the logic threshold, the design tracks the V<sub>ref</sub> input voltage at high bandwidth, operating typically at

one half the bus V<sub>DDQ</sub> voltage of 2.5V. In addition, the DDR series features a very high current slew rate of up to 40 Amps per microsecond and fast settling while switching from source to sink or sink to source. These features insure no data errors on the memory bus.

The DDR is supplied either in a vertical SIP (Single Inline Package) mount or a horizontal pinned mount. The converter meets UL 60950-1, CSA and IEC safety certifications and both conducted and radiated EMI (electromagnetic interference) specifications. The output is rated for continuous short circuit protection and the on-board controller will shut down the converter if the temperature reaches 110°C or output current exceeds 11 Amps. The DDR-9-W3H-C is available with RoHS reduction of hazardous substance compliance.

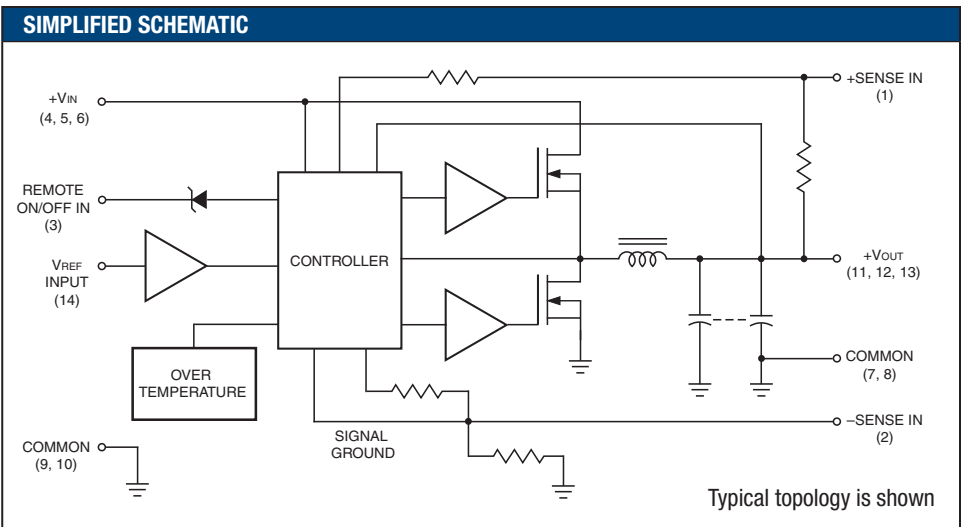

**DDR MEMORY APPLICATION**

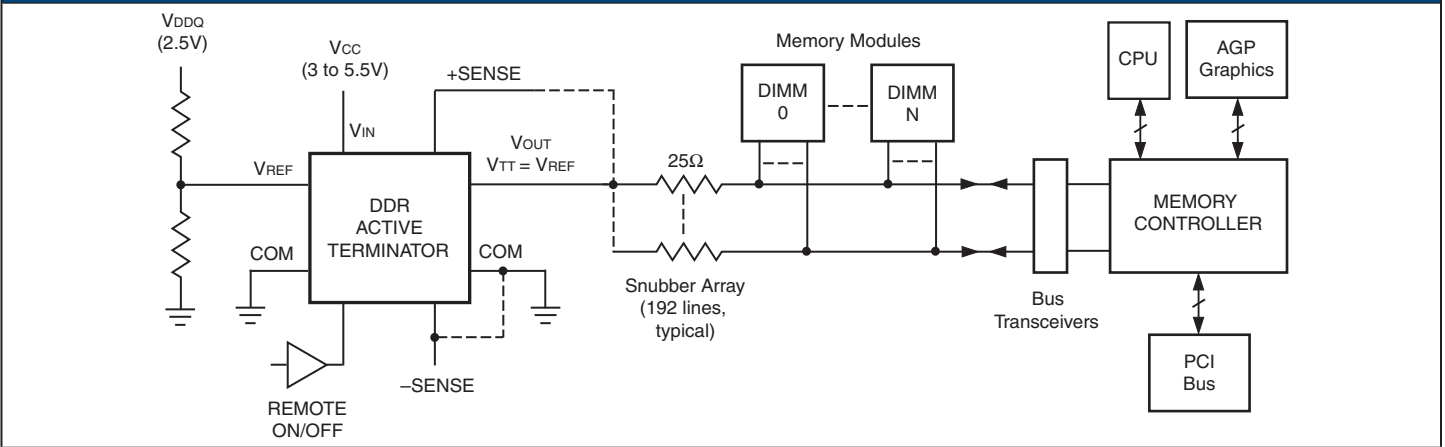

**MECHANICAL SPECIFICATIONS**

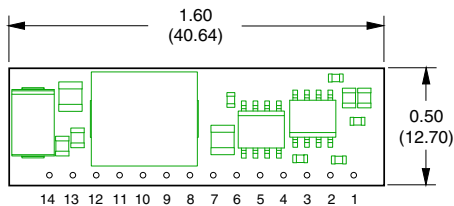

HORIZONTAL MOUNT

Case B9

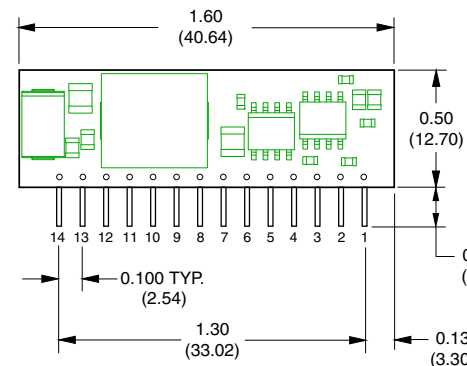
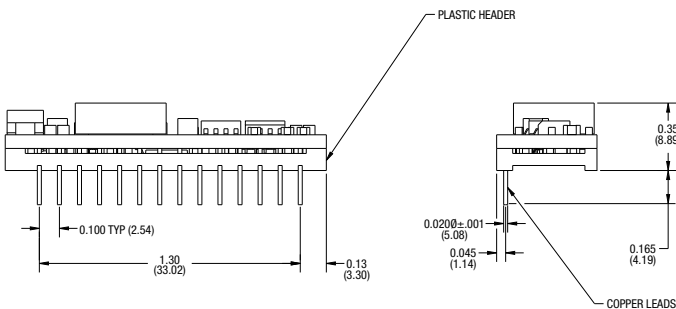

VERTICAL MOUNT

Case B10

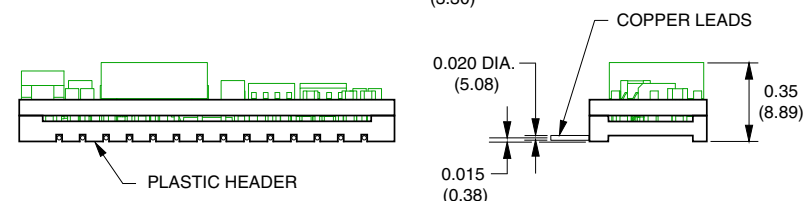

INPUT/OUTPUT CONNECTIONS			
Pin	Function P66	Pin	Function P66
1	+Sense Input	8	Common
2	-Sense Input	9	Common
3	On/Off Input	10	Common
4	+Input	11	-Output
5	+Input	12	-Output
6	+Input	13	-Output
7	Common	14	VREF Input

Component locations are typical.  
Actual units may vary slightly.

Dimensions in inches (mm)

### Performance/Functional Specifications

Typical at  $T_A = +25^\circ\text{C}$  under nominal line voltage,  $V_{OUT} = 1.25\text{V}$ , full-load conditions unless noted.

Input	
<b>Input Voltage Range</b> ①	3 to 5.5 Volts (3.3V nominal)
<b>Start-Up Threshold</b>	2 Volts min., 2.5 Volts typ.
<b>Input Current</b> , Current Sourcing Mode	
At 3.3VIN, 1.25VOUT	4.15 Amps max.
At 3.3VIN, 0.9VOUT	3.18 Amps max.
At 5VIN, 1.25VOUT	2.75 Amps max.
At 5VIN, 0.9VOUT	2.13 Amps max.
<b>Inrush Transient</b>	0.003A <sup>2</sup> /sec, maximum
<b>No-load Input Current</b>	70mA typ., 100mA max.
<b>Short Circuit Current</b>	4 Amps
<b>Shut Down Mode Input Current</b>	7mA
<b>Input Reflected Ripple Current</b> ②	10mA <sub>p-p</sub>
<b>VREF Input Range</b>	0.7 to 1.45V
<b>VREF External Reference Current</b>	0.1μA (VREF min. to max., IOUT = ±9A)
<b>Remote On/Off Control</b> +Positive Logic	On = no connection, open collector or 0.8V to +VIN max. applied at 60μA. Off = 0 to 0.7V or pulled low.
<b>Remote Sense Range</b>	+ 10% of VOUT
Output	
<b>Maximum Output Power</b>	11.36 Watts (VREF = 1.25V)
<b>Minimum Loading</b>	No minimum load
<b>Maximum Capacitive Loading</b>	2000μF, OSCON low-ESR (0.02Ω) 10,000μF (aluminum electrolytic)
<b>Output Voltage Accuracy</b>	VREF ±1%
<b>Total Accuracy</b> (Line, Load, Temp.)	±5%
<b>Output Current, Source</b>	+9.00 Amps maximum
<b>Output Current, Sink</b>	-9.00 Amps maximum
<b>Short Circuit Current</b>	13 Amps
<b>Short Circuit Duration</b>	Continuous, output shorted to ground
<b>Short Circuit Protection</b>	Fold back technique, autorecovery
<b>Current Limit Inception</b> ③	11 Amps, sourcing mode
Transfer Characteristics	
<b>Efficiency</b> , Current Sourcing Mode, 9A load	
At 3.3VIN, 1.25VOUT	83% typ., 85% max.
At 3.3VIN, 0.9VOUT	78% typ., 80% max.
At 5VIN, 1.25VOUT	82.5% typ., 84.5% max.
At 5VIN, 0.9VOUT	77% typ., 79% max.
<b>Efficiency</b> , Current Sinking Mode, 9A load	
At 3.3VIN, 1.25VOUT	81% typ., 83% max.
At 3.3VIN, 0.9VOUT	74.5% typ., 76.5% max.
At 5VIN, 1.25VOUT	80% typ., 82% max.
At 5VIN, 0.9VOUT	73.5% typ., 75.5% max.
<b>Temperature Coefficient</b>	±0.02%/°C
<b>Switching Frequency</b>	550kHz min., 700kHz max.
<b>Line Regulation</b> (VIN = min. to max.)	±0.75%
<b>Load Regulation</b> (VIN = min. to max.)	±1.5%
Dynamic Characteristics	
<b>Output Slew Rate</b>	40 Amps/μsec
<b>Load Step</b> , 0 to 9A	175mV, peak deviation
<b>Load Step Settling Time</b> , 0 to 9A	200μsec
<b>Ripple and Noise</b> , 20 MHz bandwidth	40mV <sub>p-p</sub> , typical 60mV <sub>p-p</sub> , maximum
<b>Turn-On Time</b> (Remote On/Off or VIN to VOUT regulated)	5.5msec

Environmental	
<b>Operating Temperature Range</b> (Ambient) No derating, vertical mount	-40 to +65°C @ 200 lfm airflow
<b>Derating</b>	See derating curves
<b>PCB/Case Temperature Range</b>	-40 to +100°C, no derating.
<b>Thermal Protection/Shutdown</b>	110°C
<b>Storage Temperature Range</b>	-55 to +125°C
<b>Altitude</b>	0 to 10,000 feet
<b>Relative Humidity</b>	10% to 90%, non-condensing
Physical, Safety	
<b>Outline Dimensions</b>	1.60 x 0.50 x 0.20 inches 40.64 x 12.7 x 5.08mm
<b>Weight</b>	0.25 ounces (7g)
<b>Pin Material</b>	Nickel plate over copper alloy
<b>Pin Dimensions</b>	0.02 inches (0.508mm)
<b>Calculated MTBF</b> ④	TBD hours
<b>Electromagnetic Interference</b>	Conducted (FCC part 15, EN55055) Radiated (FCC part 15, EN55055)
<b>Safety</b>	UL/cUL 60950-1, CSA-C22.2 No.234 IEC/EN 60950-1

① See Absolute Maximum Ratings for allowable input voltage.

② Input Ripple Current is tested and specified over a 5-20 MHz bandwidth. Input filtering is  $C_{IN} = 200\mu\text{F}$ ,  $C_{BUS} = 1000\mu\text{F}$ ,  $L_{BUS} = 1\mu\text{H}$ .

③ Current limit inception is given at either cold start-up or after warm-up for  $V_{REF} = 0.9$  or 1.25V.

④ Mean Time Before Failure is calculated using the Telecordia (Bellcore) SR-332 Method 1, Case 3, ground fixed conditions,  $T_{CASE} = +40^\circ\text{C}$ , Full load.

Absolute Maximum Ratings	
<b>Input Voltage</b>	7Vdc max., 100msec duration
<b>Input Reverse Polarity</b>	None
<b>Output Current</b>	Current-limited. Device can withstand indefinite short circuit.
<b>Storage Temperature</b>	-55 to +125 °C
<b>Lead Temperature</b>	+300°C, 10 seconds maximum
Absolute maximums are stress ratings. Exposure of devices to any of these conditions may adversely affect long-term reliability. Proper operation under conditions other than those listed in the Performance/Functional Specifications Table is not implied nor recommended.	

### Ordering Guide

Model Number	Mounting
DDR-9-W3	Single Inline Package (vertical), non-RoHS
DDR-9-W3-C	Single Inline Package (vertical), RoHS compliant
DDR-9-W3H	Horizontal mount, non-RoHS
DDR-9-W3H-C	Horizontal mounting, RoHS compliant

**Typical Performance Curves**

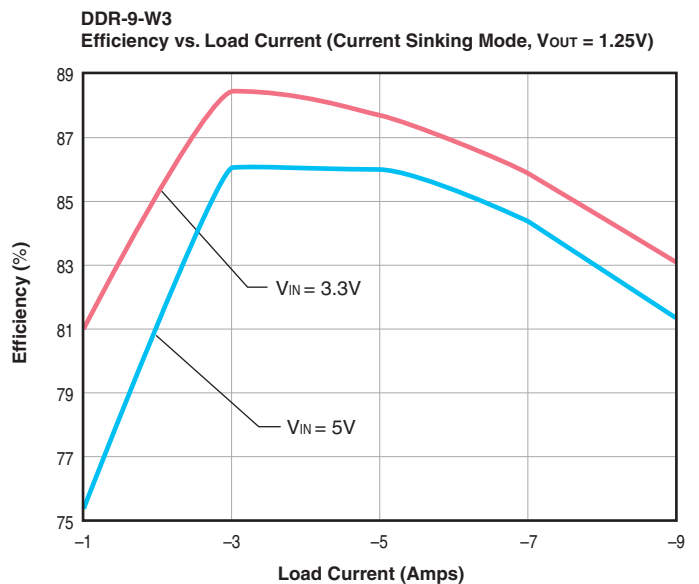
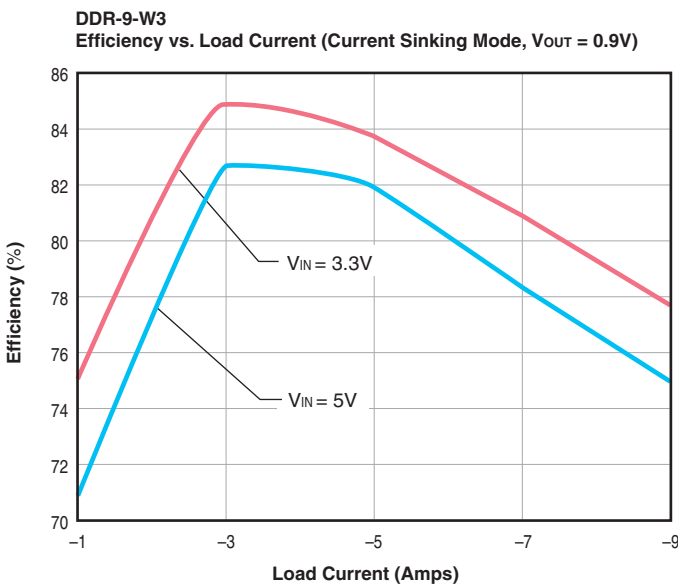
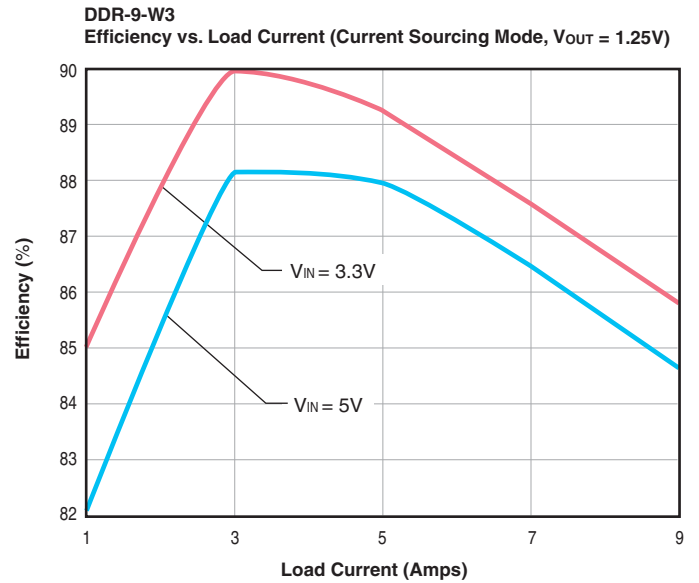
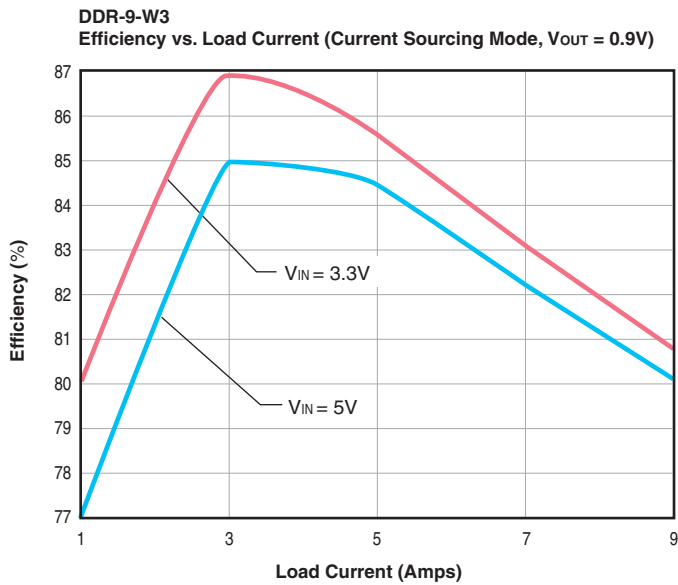

**Typical Performance Curves**

**DDR-9-W3 Maximum Current Temperature Derating**  
(3.3V<sub>IN</sub>, 0.9V<sub>OUT</sub>, Current Sourcing Mode)

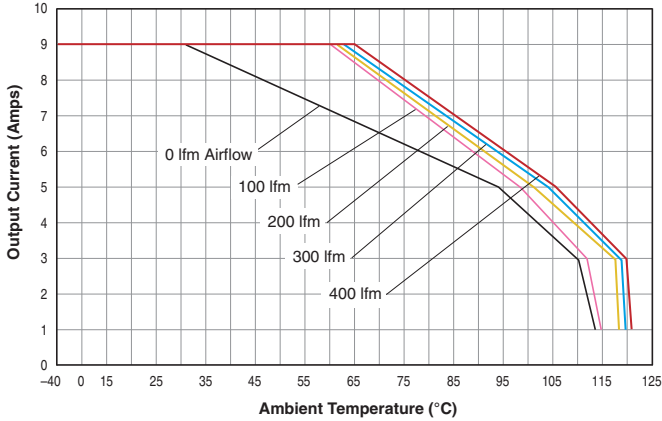

**DDR-9-W3 Maximum Current Temperature Derating**  
(3.3V<sub>IN</sub>, 1.25V<sub>OUT</sub>, Current Sourcing Mode)

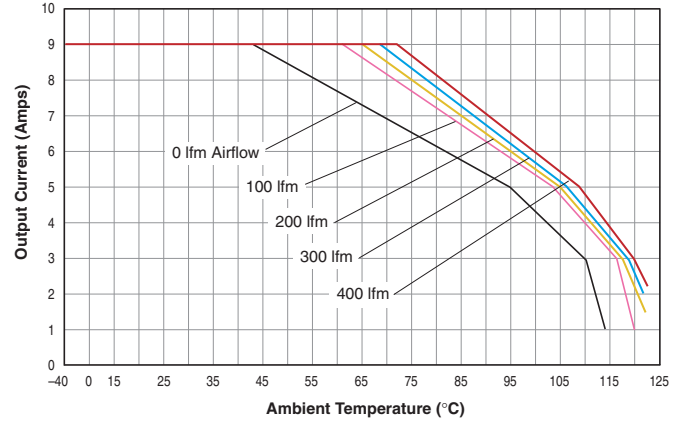

**DDR-9-W3 Maximum Current Temperature Derating**  
(5V<sub>IN</sub>, 0.9V<sub>OUT</sub>, Current Sourcing Mode)

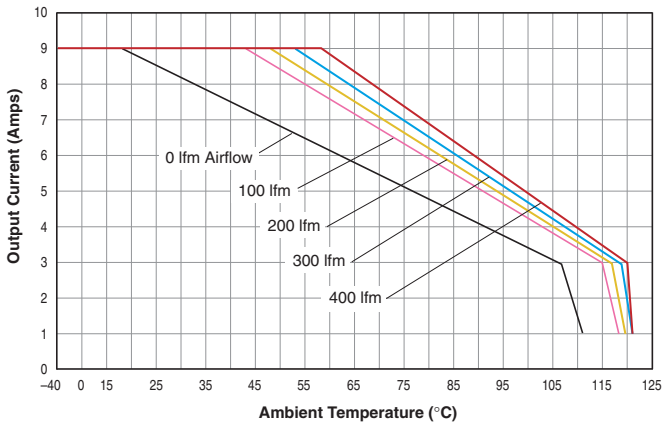

**DDR-9-W3 Maximum Current Temperature Derating**  
(5V<sub>IN</sub>, 1.25V<sub>OUT</sub>, Current Sourcing Mode)

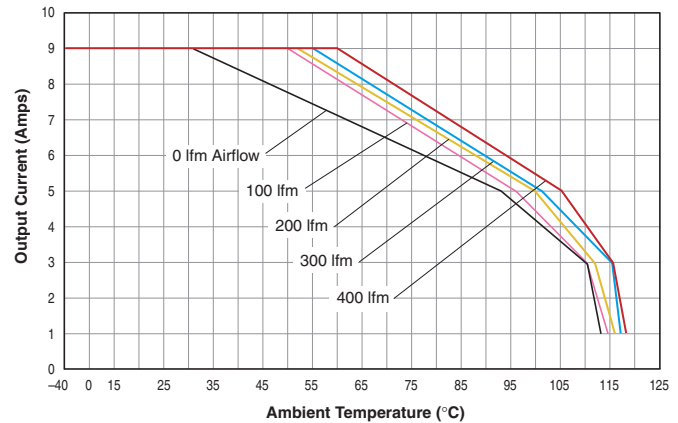

Murata Power Solutions, Inc.  
11 Cabot Boulevard, Mansfield, MA 02048-1151 U.S.A.  
Tel: (508) 339-3000 (800) 233-2765 Fax: (508) 339-6356  
[www.murata-ps.com](http://www.murata-ps.com) email: [sales@murata-ps.com](mailto:sales@murata-ps.com)  
ISO 9001 REGISTERED

2/29/08

Murata Power Solutions, Inc. makes no representation that the use of its products in the circuits described herein, or the use of other technical information contained herein, will not infringe upon existing or future patent rights. The descriptions contained herein do not imply the granting of licenses to make, use, or sell equipment constructed in accordance therewith. Specifications are subject to change without notice.  
© 2008 Murata Power Solutions, Inc.

- USA:** Tucson (AZ), Tel: (800) 547 2537, email: [sales@murata-ps.com](mailto:sales@murata-ps.com)
- Canada:** Toronto, Tel: (866) 740 1232, email: [toronto@murata-ps.com](mailto:toronto@murata-ps.com)
- UK:** Milton Keynes, Tel: +44 (0)1908 615232, email: [mk@murata-ps.com](mailto:mk@murata-ps.com)
- France:** Montigny Le Bretonneux, Tel: +33 (0)1 34 60 01 01, email: [france@murata-ps.com](mailto:france@murata-ps.com)
- Germany:** München, Tel: +49 (0)89-544334-0, email: [ped.munich@murata-ps.com](mailto:ped.munich@murata-ps.com)
- Japan:** Tokyo, Tel: 3-3779-1031, email: [sales\\_tokyo@murata-ps.com](mailto:sales_tokyo@murata-ps.com)  
Osaka, Tel: 6-6354-2025, email: [sales\\_osaka@murata-ps.com](mailto:sales_osaka@murata-ps.com)  
**Website:** [www.murata-ps.jp](http://www.murata-ps.jp)
- China:** Shanghai, Tel: +86 215 027 3678, email: [shanghai@murata-ps.com](mailto:shanghai@murata-ps.com)  
Guangzhou, Tel: +86 208 221 8066, email: [guangzhou@murata-ps.com](mailto:guangzhou@murata-ps.com)

