



- Magnetic principle
- Excellent resistance to workshop conditions. Resistant to oil, dirt and vibrations.
- Thin design
- Directly mountable onto a machine's rotary shaft. Large-diameter scale drum that can be used for large-sized machines such as turning centers.
- Easy installation
- Noncontact. Clearance: 0.1 mm/ 0.004"

Example for connection

Scale	Cable	Interpolator
RS310	AK2-C	MD20B

Dimensions

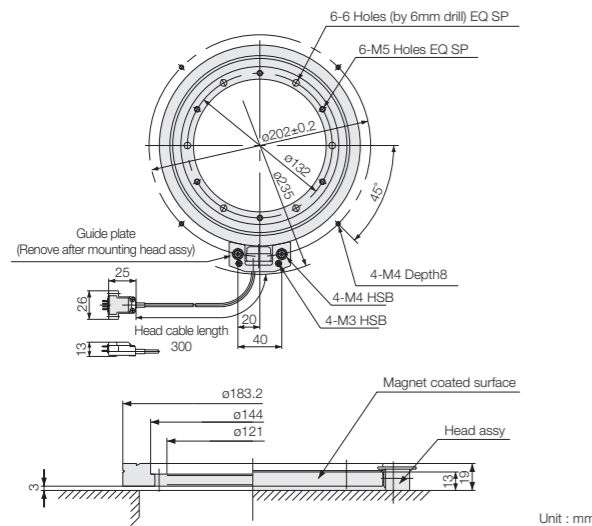

System configuration

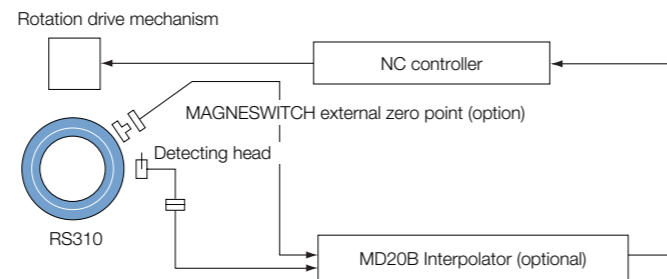

Interpolators

Specifications

Model		RS310-1800A
No. of reader heads		1
No. of recorded waves		1800 λ / revolution
Recorded wave length		0.32 mm
Resolution		0.001"
Clearance		100 to 110 μm (recommended)
Cumulative pitch accuracy *1		7.2"
Interpolation accuracy		3.6" ^{**2}
Allowable scale drum runout		Keep to min. at installation ^{*1}
Allowable head mounting face flatness		5 μm or less (No burrs or unevennesses)
Allowable residual machine magnetism		0.25 mT
Max. mechanical revolutions		7000 min ⁻¹
Scale drum	Dimensions	ø 183.4 x ø 121 x 16 mm (ø 7.23" x ø 4.77" x 0.63") (Outer dia. x inner dia. x thickness)
	Mounting pitch dia	ø 132 mm/ 5.20"
	Mass	Approx. 1.6 kg/ 3.53 lbs
	Moment of inertia	1.12 x 10 ⁻² kg m ²
Diameter excl. cable guide		Max. approx. ø 235 mm/ 9.26"
Operating temperature		0 °C to 40 °C/ 32 °F to 104 °F
Storage temperature		-10 °C to 50 °C/ 14 °F to 122 °F
Reader heads	Mass	Approx. 0.12 kg/ 0.26 lbs
	Cable length	300 mm/ 11.8"

*1 RS310-1800A Cumulative pitch error will be less than 7.2" with circumference eccentricity of 3 μm. More eccentricity, Add 2.3"/1 μm

RS310-1800B Cumulative pitch error will be less than 7.2" with circumference eccentricity of 30 μm. Total accuracy is sum of cumulative pitch error and interpolation error

**2 3.6" interpolation error for 1.5% of PM signal ripple

MJ100/110
 MJ620
 MJ820/821
 MJ830/831