



Long-life energy saving lamp

Versatile

Selective illumination

Handlamp for the use in enclosures with electrical/electronic components. The lamp is removable and therefore suitable for a selective illumination.



Technical Data

Luminosity	1.000Lm (equals 100W light bulb)
Lamp type	energy saving lamp, E27 socket
Service life	10,000h
Connection	power cable (2m) with Euro plug
Mounting	screws or fixing plate (self-adhesive)
Casing	plastic according to UL94 V-0, light grey
Weight	approx. 0.6kg
Fitting position	variable
Operating / Storage temperature	-20 to +50°C (-4 to +122°F) / -45 to +70°C (-49 to +158°F)
Operating / Storage humidity	max. 90% RH (non-condensing)
Protection type / Protection class	IP20 / II (double insulated)
Approvals	-
Included in delivery	lamp holder, hook and fixing plate
Note	120VAC and DC voltages on request

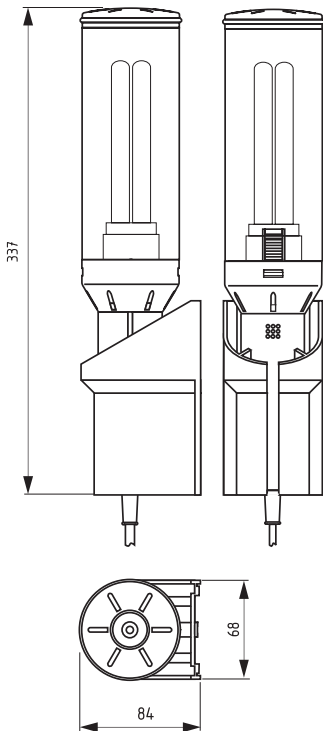

Art. No.	Operating voltage	Power consumption
02610.0-00	230VAC, 50Hz	20W