

GE
Sensing

Druck PC6-IDOS

Pressure calibrator (Bench/panel mount version)

User manual - K0354

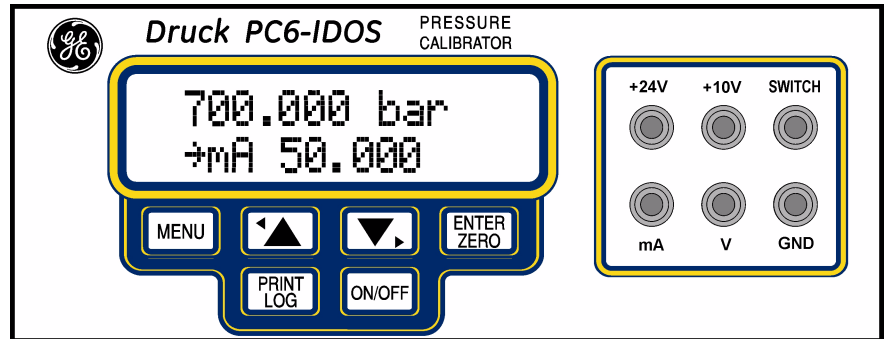

Publication

K0354, Issue 1

Copyright

© 2006 General Electric Company. All rights reserved.

Trademarks

All product names are trademarks of their respective companies.

CONTENTS

Welcome (Indicator Note)	ii
Safety Warning	iii
Quick Reference (Keys, Activating functions, Exit, Menu selection, Data Entry, Tare)	iv
Specifications	v
Maintenance	vi

Description 1

1.0 Introduction	2
1.1 General	2
1.2 Keypad	2
1.3 LCD	3
1.4 Connection Panels (Front/Rear)	3
1.4.1 4 mm Sockets	3
1.4.2 Quick connect coupling	3
1.4.3 RS232	3
1.4.4 Charger	3
1.4.5 EPM	3
PC6-IDOS Arrangement	4
Functions (menu 1)	5
Functions (menu 2)	6
Functions (menu 3)	8

Operating Instructions 9

1.5 Introduction	10
1.6 Connections	10
1.6.1 Pressure Input	10
1.6.2 EPM	10
1.6.3 Voltage/Current Input	10
1.6.4 Switch Test.....	11
1.6.5 RS232	11
1.6.6 Battery charger	11
1.6.7 Voltage Output	11
1.7 Messages & Parameters.....	12
1.7.1 Retained parameters	12
1.7.2 Battery low state	12

1.7.3 Tare Value	12
1.7.4 Maximum/Minimum	12
1.7.5 Void leak test	12
1.7.6 Switch Off	12
1.7.7 Auto Switch Off	12
1.7.8 Pressure Overload	12
1.7.9 Low Battery Detect	12
1.7.10 Pressure Switch State Change	12
1.7.11 Printer Busy	12
1.7.12 Outside User Set Alarm Value	12
1.7.13 Display Hold	12
1.7.14 Connection Fault	13
1.7.15 Short Detected	13
1.7.16 Voltage / Current Overscale	13
1.7.17 RS232 Output Format	13
1.7.18 Alarm Flag	13
1.7.19 Symbols	13

How to Select Functions (Menu 1) 14

1.8 Units	15
1.9 Max, Min, Switch, Temp., Date & Time, %	15
1.10 Tare	15
1.11 V / mA	15
1.12 Leak Test	17
1.13 File (logged files)	18

Set-menu (menu 2) 20

2.0 Alarm Settings - High / Low	21
2.1 V / mA (Measure mode).....	22
2.2 V / mA (Source mode).....	23
2.3 V-Out, Display light, Port	26
2.4 Resolution	26
2.5 Event	26
2.6 Log	27
2.7 RS232	29
2.8 Date & Time	30
2.9 Language	30
2.10 Zero	30
2.11 Port.....	31

2.12 Power_Off	31
-----------------------------	----

Cal-menu (menu 3) 32

3.0 Span	33
3.1 History (overload, zero/span, ...).....	35
3.2 Language	35
3.3 Units	35

Flowcharts 36

Menu 1, Menu 2 & Menu 3	37
--	----

Menu 1 Unit, Leak	38
V / mA	39
File	40
Menu 2 High & Low	41
V / mA (measure)	42
V / mA (source)	43
V-out, Display light	48
Resolution, Event, RS232	48
Log	49
Date&Time, Language, Zero, Port, Power_Off	50
Menu 3 Span	51
History	52
Language	53
Units	54

Appendices 55

1 External Pressure Module (EPM)	55
2 Calibration Procedures.....	58
3 Panel Mount Dimensions.....	60

Index 62

WELCOME

This detailed operating manual will help you to become familiar with the many features of the PC6-IDOS Calibrator. The simple step by step instructions will quickly guide you through the procedures for using the calibrator and other items needed for accurately testing and calibrating numerous types of instruments. Please take time to carefully read the whole manual before you begin to use the PC6-IDOS.

Two versions of the PC6-IDOS are available:

PC6-IDOS Calibrator:

All of the functions shown in this manual apply to this unit. The PC6-IDOS Calibrator can be supplied with a PV210 Low pressure pneumatic test system for pressures up to 3 bar (45 psi), PV211 pneumatic test system for pressures up to 40 bar (600 psi) or PV212 hydraulic test system for pressures up to 700 bar (10,000 psi). Refer to the instructions supplied with the applicable pressure system.

PC6-IDOS Indicator:

This is a simplified version of the PC6-IDOS Calibrator and does not include the Voltage/Current input/output.

SAFETY WARNING!

HIGH PRESSURE:

Uncontrolled release of high pressure is hazardous to personnel and may cause damage to equipment. Before connection of any pressure component to the PC6-IDOS ensure that the component(s) is/are isolated from the pressure supply and any internal pressure is released slowly.

RECHARGEABLE Ni-MH BATTERIES

Rechargeable Ni-MH batteries must be recycled or disposed of properly.
May explode if damaged or disposed of in fire. **DO NOT** short-circuit.
CAUTION: Use charger supplied by GE Sensing only.



QUICK REFERENCE

Keys



Press to turn PC6-IDOS on and off



Press to access the menus



Press to accept functions or settings



Press to move cursor up/left or increase values



Press to move cursor down/right or decrease values



Press to print/log/start event depending on previous setting

Activating Functions



Select menu



position cursor
under function



press the Enter key

Exit

To exit out of any menu PC select 'Exit' option,
or press key.

Menu Selection

Pressure
Display



1st Press for Menu 1

2nd Press for Menu 2

3rd Press back to Pressure Display /
Calibration Menu (see page 33)

Data Entry

Press or to position cursor and press to select required alphanumeric. Press key to release cursor.

For next data entry, repeat the above procedures then press once all data is entered.

Note: To quickly scroll through alphanumeric lists hold down the or key.

Tare Hold down the key for 4 seconds while in the pressure display mode. The unit will bleep after two seconds when the Max. and Min. values reset. After another two seconds a second bleep will sound as the displayed pressure now resets to zero. **This is a temporary function and will be cancelled when the unit is switched off.**

SPECIFICATIONS

Model		Pressure Range		Accuracy (FS) up to
		Bar	psi	
PC6-B-0.07-C	G	-0.07 to 0.07	-1.0 to 1.0	0.05%
PC6-B-0.2-C	G	-0.2 to 0.2	-3.0 to 3.0	0.05%
PC6-B-0.35-C	G	-0.35 to 0.35	-5.0 to 5.0	0.05%
PC6-B-0.7-C	G	-0.7 to 0.7	-10 to 10	0.05%
PC6-B-1-C	G	-1 to 1	-15 to 15	0.025%
PC6-B-2-C	G or A [†]	-1 to 2	-15 to 30	0.025%
PC6-B-3.5-C	G	-1 to 3.5	-15 to 50	0.025%
PC6-B-7-C	G or A [†]	-1 to 7	-15 to 100	0.025%
PC6-B-10-C	G	-1 to 10	-15 to 150	0.025%
PC6-B-20-C	G or A [†]	-1 to 20	-15 to 300	0.025%
PC6-B-35-C	G	-1 to 35	-15 to 500	0.025%
PC6-B-70-C	G	0 to 70	0 to 1,000	0.025%
PC6-B-100-C	G	0 to 100	0 to 1,500	0.025%
PC6-B-200-C	G	0 to 200	0 to 3,000	0.025%
PC6-B-350-C	SG	0 to 350	0 to 5,000	0.025%
PC6-B-700-C	SG	0 to 700	0 to 10,000	0.025%

Other Pressure ranges are available to special order.
 SG = Sealed Gauge, G = Vented Gauge, A = Absolute
[†] 0.075% FS accuracy, 0 to 50 °C (32 to 122 °F)

Measurement	Range	Resolution	Accuracy	Input resistance
Voltage * (Auto Range)	0 to 100mV	1μV	0.025% FS	1 MΩ
	0 to 5V	0.1mV	0.025% FS	1 MΩ
	0 to 50V	1mV	0.025% FS	1 MΩ
Current * Auto Range	0 to 50mA	1μA	0.025% FS	6 Ω
	0 to 25mA		0.025% FS	

Sourcing	Range	Resolution	Accuracy	Max. Load
Voltage *	0 to 10V	0.2mV	0.025% FS	20mA
Current *	0 to 50mA	1μA	0.025% FS	330 Ohm

* Temperature coefficient ± 0.005% of reading / °C w.r.t. 20°C (68°F)

Overload Pressure Resolution EPM

15% FS
 6 Digits
 External Pressure Modules. See Appendix 1 for EPM details.

Pressure Units

bar, mbar, MPa, kPa, psi, kg/cm², atm, inH₂O, mmHg, mmHg, inHg, mmHg, UNIT1, UNIT2 (user defined)

Overload Warning Temperature Display

Flashing display and audible tone at 115% of FS
 Temperature of pressure sensor
 (Accuracy: ±1 °C (1.8 °F))

Pressure Switch Test

Status OPEN/CLOSED

Operating Temperature Calibration Temperature Calibrated Temp. range Storage Temperature Temperature Effects

0 to 50 °C (32 to 122 °F)
 20 ±2 °C (68 ±3.6 °F)
 5 to 45 °C (41 to 113 °F)
 -20 to 70°C (-4 to 158 °F)
 Temperature effects are included in the accuracy.

RS232 Parameters

baud rate 1200, 2400, 4800, 9600, 19200 and 38400. Stop bits 1 or 2, status ON/OFF

Zero Reset Data Capacity

Manual keyboard operation
 1011 records into a maximum of 20 files,
 64k memory

Display Humidity Resolution Select Power Supply

Backlit LCD, 16 character x 2 line alpha numeric
 5 to 95% Relative Humidity non condensing
 Increase or decrease by a factor of 10
 6V Ni-MH rechargeable battery pack (see warning on page iii)/ mains operation via charger (supplied).

Voltage Output

Regulated DC supply 10V ± 0.1%
 max current 10mA
 Unregulated DC supply 24V ± 10%
 max current 50mA

SPECIFICATIONS / MAINTENANCE

Battery Life	Fully charged: up to 8 hours ¹
Recharge Time	14-16 hours for full charge
Low Battery	Continuous check, audio and visual warning

Dimensions (l: w: h) 200 x 180 x 85 mm (7.9 x 7.1 x 3.3 in)

Weight Approximately 1.8 kg (4 lb)

Microprocessor H8S/2138

Recommended Recalibration Period 1 Year (Max)

Electrical Connections

Ground	Standard 4 mm socket
Voltage/Current Input/Output	Standard 4 mm sockets
Pressure Switch Input	Standard 4 mm sockets
Battery	2 pole miniature round connector
RS232	8 pole miniature round connector
EPM (P2)	5 pole miniature round connector

Pressure Media Water, Mineral Oil, Non-corrosive gases
(for other media, contact GE).

Pressure Connection 'quick-fit' connector / 1/4" BSP or 1/4" NPT female adaptors.

Software (optional) The '*SiCal PRO*' software will present downloaded data in various graphical forms such as gauges or a scrolling bar & remotely control the PC6-IDOS via the RS232 cable linked to a PC. The downloaded data can be stored in a variety of file types compatible with most analysis database and word processing programs. Calibration procedures can be uploaded to the PC6-IDOS.

System requirements: Minimum Intel Pentium® with Windows® 95 or higher.

¹ The battery usage time specified here is heavily dependent upon the functions selected. For instance, using the back-light function will reduce the battery usage time, as will source mode functions.

Ordering Codes:

PC6 - B - XXXX - XXXX - C - 1

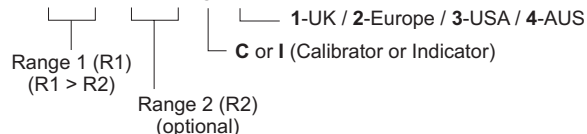

For Panel Mount version add a 'P' to the order code i.e. PC6-BP-XXXX-XXXX-C-1. See page 61 for panel dimensions.

Maintenance

Clean the case with a moist, lint-free cloth and a weak detergent. Do not use solvents or abrasive materials.



Do not do local repairs. Return the equipment to the manufacturer or an approved service agent.

Do not dispose of this product as household waste. Use an approved organisation that collects and/or recycles waste electrical and electronic equipment.

For more information, contact one of these:

- our customer service department
(Contact us at www.gesensing.com)
- your local government office

DESCRIPTION

1.0 Introduction

The PC6-IDOS Pressure Calibrator is a microprocessor controlled, precision instrument powered by an internal 6V rechargeable battery pack. It is portable and capable of accurate pressure measurement, voltage or current measurements and sourcing when calibrating transducers, pressure switches, etc. This section describes the equipment from an external viewpoint, allowing the user to become familiar with the various controls and connections provided.

1.1 General

The PC6-IDOS is housed in a painted metal case with a carry handle/stand, a liquid crystal display unit at the front and a six button keyboard. The main body contains the circuitry, connections, internal transducer(s) and battery pack.

1.2 Keypad

The Keypad is a non-tactile membrane keyboard with six buttons. The keyboard layout is shown below.

Note: An audible tone accompanies every key operation.

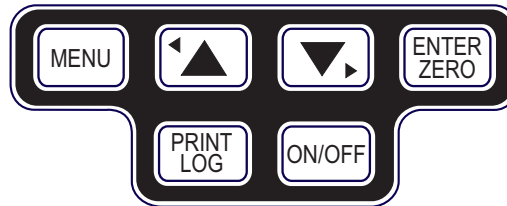

1.3 Liquid Crystal Display (LCD)

The LCD is a 16 character x 2 line alphanumeric LED backlit display which is capable of displaying special characters.

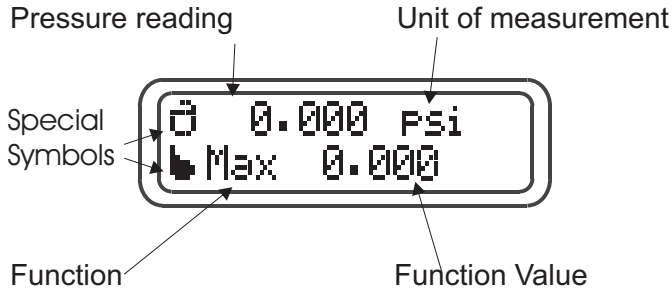

1.4 Connection Panels (Front/Rear)

Front connection panel: (See Page 4, Fig 1)

This connection panel provides input / output connections as detailed in Fig.1

1.4.1 4 mm sockets. Six standard 4 mm electrical sockets mounted on the front panel provide input or output current and voltage and switch status.

Voltage outputs of 10 and 24V are available for use with sensors, transducers, transmitters, etc.

Rear connection panel:

(See Page 4, Fig 2)

1.4.2 'Quick Fit' coupling. Pressure input connections are made to 'Quick-fit' connectors / 1/4BSP or 1/4NPT female adaptors.

1.4.3 RS232. An 8 way circular miniature connector is used for communication with RS232 standard communication protocols/equipment. The user software '*SiCal PRO*' (optional) can be used to remotely monitor or download/upload data from the PC6-IDOS via this connector.

(Optional RS232 cable - Part No. 01-0625)

1.4.4 Charger. The 2 way circular miniature connector is used for the 9V charger/power supply (provided).

1.4.5 EPM. The 5 way circular miniature connector is used to connect to the EPM (External Pressure Module). These optional modules cover pressure ranges from 0.07 to 700 bar (1.0 to 10,000 psi).

Note: This connector will not be available on a dual (internal) sensor unit.

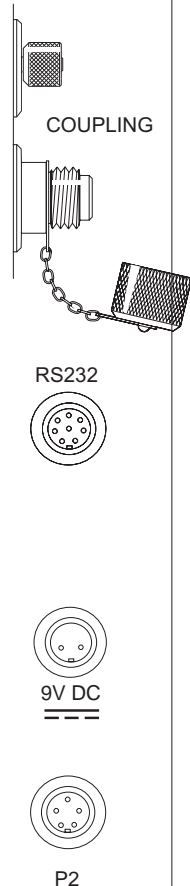

ARRANGEMENT OF PC6-IDOS

Front View:
LCD, Keypad & Connections
Fig 1

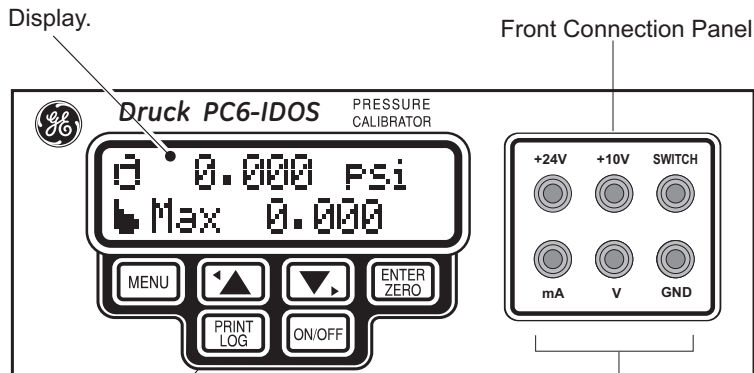

Keypad
See Page 2

(See Page 10
for V/mA
connections)



+24 V	Volts output.
+10 V	Volts output.
GND	Common Ground Socket
mA	Milliamp Input (controls input current in source mode).
V	Volt Input (output in source mode).
SWITCH	Pressure Switch Input.

Rear View:
Pressure / RS232 / Power connections
Fig 2

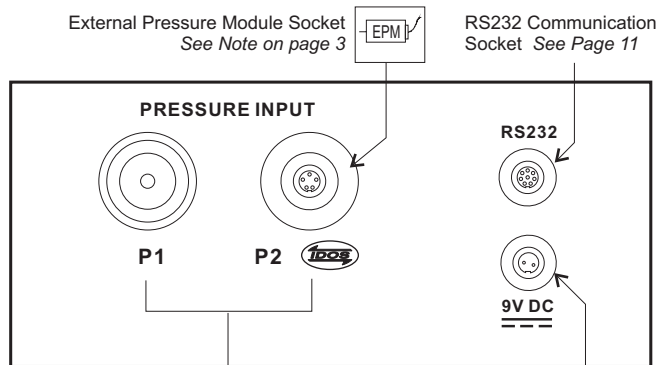

Pressure Input connections
See Page 3

9V DC / Battery Charger
Input Socket
See Page 11

FUNCTIONS (MENU 1)

PRESSURE DISPLAY - Allows the user to operate the PC6-IDOS for pressure measurements. (Display Functions)

Menu 1

Unit	Selection of pressure unit.		
bar	bar	----	mbar millibar
MPa	megapascals	----	kPa kilopascals
psi	pounds force per square inch	----	kg/cm² kilograms force per square centimetre
atm	atmospheres	----	inH₂O inches of water (at 4°C)
mH ₂ O	metres of water (at 4°C)	----	mmH₂O millimetres of water (at 4°C)
inHg	inches of mercury (at 0°C)	----	mmHg millimetres of mercury (at 0°C)
UNIT1	user defined unit	----	UNIT2 second user defined unit
Exit	Returns to menu 1		
Max	Displays the maximum pressure measured since the last reset (60 samples per second).		
Min	Displays the minimum pressure measured since the last reset (60 samples per second).		
%	Displays the pressure as a percentage between user pre-set high and low alarm values.		
Tare	Displays the pressure at the time of tare.		
V / mA	Volts / milliamps functions		
Measure	Displays the following input measurements.		
Actual	Displays actual input measurements.		
Converted	Displays converted input measurements.		
Exit	Returns to Pressure Display.		
Source	Displays the following outputs (status must be ON - see 'Setup' in Menu 2)		
Actual	Displays actual output measurements.		
Converted	Displays converted output measurements.		
P to V / P to mA	Displays Pressure to Volts / milliamps conversion.		
Exit	Returns to Pressure Display.		
Exit	Returns to pressure display		
Switch	Indicates the status of the pressure switch under test (OPEN/CLOSED).		
Leak	Allows the PC6-IDOS to measure pressure changes over time.		
Start	Starts the leak test.		
Set-Time	Sets the leak test time.		
Exit	Returns to Pressure Display.		
Temp C	Allows the user to monitor the temperature around the selected pressure transducer in pressure display mode.		
Date & Time	Allows the user to monitor the date & time of the on board real time clock in pressure display mode.		
File	Allows the user to view or manipulate a file previously stored in the filing system.		
View	Allows the user to see logged file.		
Export	Outputs a logged file		
Import	Imports a file (refer to 'SiCal PRO' instructions for exporting files to PC6-IDOS)		
Delete	Deletes a single file or all logged files.		
Exit	Returns to Pressure Display.		
Exit	Returns to Pressure Display mode. (SHORTCUT: To abort any menu level, simply press the MENU key).		

FUNCTIONS (MENU 2)

SETTING MENU - To set user specific functions. (*Set Functions*)

Menu 2

<ul style="list-style-type: none"> High } <ul style="list-style-type: none"> Low } V / mA — Measure <ul style="list-style-type: none"> Zero FS Text Root Exit Source <ul style="list-style-type: none"> Range <ul style="list-style-type: none"> Zero FS Exit Convert <ul style="list-style-type: none"> Zero FS Text Exit P to V / mA <ul style="list-style-type: none"> Zero FS Exit Setup <ul style="list-style-type: none"> Status Root Step Ramp <ul style="list-style-type: none"> Status Rate Dwell_time Exit Exit 	<p>Allow the user to set a High or Low Pressure Alarm Limit. (by using the increase/decrease facility above which an alarm sounds.)</p> <p>Voltage / Current input settings for Converted Measurement. Set Zero. Set Full scale value. User defined measurement text. Switch measurement root function 'on' or 'off'. Reverts back to Pressure Display.</p> <p>Voltage / Current output settings. Sets the following values:- Sets Zero value Sets Full Scale value Returns to Source sub-menu.</p> <p>Sets the following converted values:- Sets converted Zero values. Sets converted Full Scale values. User defined converted text. Returns to Source sub-menu.</p> <p>Sets Pressure to V / mA conversion factors. Set zero values. Set Full Scale values. Returns to Source sub-menu.</p> <p>Sets the parameters for voltage/current sourcing. Switches output on or off. Switch sourcing root function 'on' or 'off'. Set step value (%FS) Settings for Ramp mode Switches ramp mode on or off. Sets the ramp rate (V or mA/Sec). Sets the time for which the output remains at the same level. Returns to Source sub-menu.</p> <p>Returns to Pressure Display.</p>
---	---

Continued on
Page 7

FUNCTIONS (MENU 2) Continued.

—	Vout	Switches the Power Supply outputs +10V & +24V ON or OFF
—	Display Light	Switches ON or OFF the LED back light.
—	Resolution	Selects low, normal or high resolution.
—	Event	Sets up the event status for RS232 output and for logging functions.
—	Key	Sets key driven output or logging.
—	Timed	Sets timed output defined by the user.
—	Exit	Reverts back to Pressure Display.
—	Log	Allows the user to setup, amend and view files for logging.
—	Log	To select a log file and start logging.
—	View	To look at a file.
—	Delete	Deletes a file.
—	Status	To enable or disable logging.
—	Export	To export logged files.
—	Import	To import files from a PC. (see ' <i>SiCal PRO</i> ' software instructions for exporting files to the PC6-IDOS)
—	Exit	Reverts back to Pressure Display.
—	RS232	Settings for RS232 communications.
—	Status	To enable RS232 communication.
—	Baud-rate	To select the baud rate.
—	Stop-bits	To select the number of stop bits.
—	Exit	Reverts back to Pressure Display.
—	Date/Time	Sets up Date & Time parameters
—	Set	Sets the date & time.
—	View	To look at date & time.
—	Exit	Reverts back to Pressure Display.
—	Language	Allows user to change language (separate pc software utility needed -contact supplier).
—	Zero	Will reset pressure reading to Zero. (This will remove Zero offset permanently / NOT available for absolute units).
—	Port	Selects current pressure module (P1, P2)
—	Power_Off	Allows the user to set Power_Off time or to switch the function on or off.
—	Key	Switches the auto-power function off.
—	Timed	Allows the user to set the auto-power off time in minutes.
—	Exit	Reverts back to Pressure Display.
—	Exit	Returns to Pressure Display

FUNCTIONS (MENU 3)

CAL MENU

Menu 3

	Span	Allows user to set span.
		Continue Starts span calibration procedure.
		Exit Returns to Cal Menu.
	History	Allows user to see overload and zero-span history.
		Overload Displays period of time over which overload occurred.
		Zero-Span Displays date last calibrated, last span set, range and overload value.
		PC6S/No Displays the unit's serial number.
		PM S/No Displays the serial number of the currently selected pressure module.
		Exit Returns to Cal Menu.
	Language	Allows user to download different languages.
	Units	
		View Displays the two current user-defined units.
		Alter Allows user to modify the conversion factor and/or text for the two user-defined units.
		Exit Returns to Cal Menu
	Exit	Returns to Pressure Display.

OPERATING INSTRUCTIONS

1.5 Introduction

The PC6-IDOS enables the user to carry out checks on pressure transducers, transmitters, pressure switches, pressure gauges and process indicators quickly and accurately. It is intended for use as a portable, on-site calibrator, used in close proximity with the equipment under test and without the need to remove the unit from its parent system. This section describes the connections to be made when checking switches, transmitters, etc. It also lists menu options, selection procedures and purpose of options available.

1.6 Connections

1.6.1 Pressure Input The PC6-IDOS measures pressure directly via the 'Quick-Fit' connectors found at the rear of the case. Alternatively, connect the item under test to the PC6-IDOS with the adaptors and seals provided.

1.6.2 EPM (External Pressure Module)

Different pressure ranges can be read by attaching an External Pressure Module to the 5-way socket (only available on single range instruments - See Fig.2).

Warning: The PC6-IDOS must be switched off prior to connecting or disconnecting the EPM .

1.6.3 Voltage / Current Input / Output Voltage and Current readings can be taken by connecting the outputs from the item under test to the 'V' or 'mA' and 'GND' input sockets on the connection panel using the connection leads provided.

Warning: When measuring voltage or current, make sure 'GND' is connected (where applicable, see fig. 3)

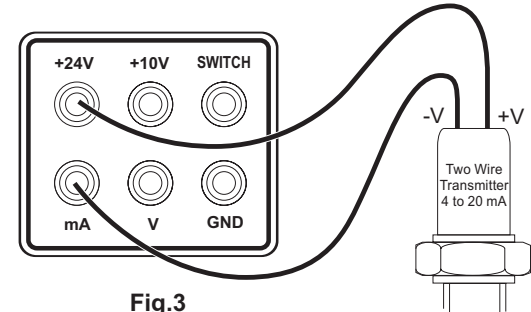
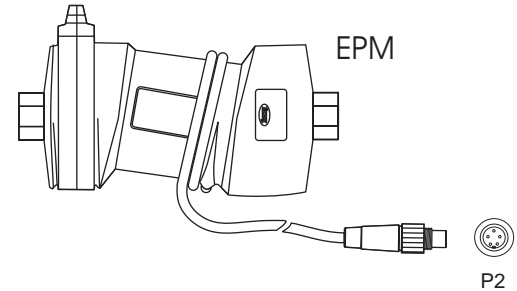
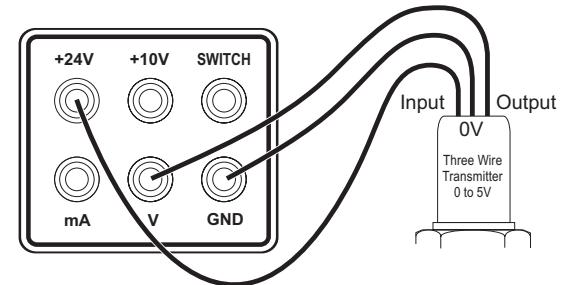

Fig.3



1.6.4 Switch Test Activate 'Switch' function in menu 1. The switching pressure of a pressure switch can now be monitored by connecting the contacts of the pressure switch between the INPUT 'GND' and 'SWITCH' sockets on the connection panel and pressurizing the pressure switch.

1.6.5 RS232

If the RS232 facility is to be used then connections to the 8-way socket must be made to the specifications given in the table below. Alternatively an RS232 communication cable can be purchased from GE suitable for most RS232 applications as shown below.

To RS232 socket on PC6-IDOS



Cable Part No: 01-0625

Standard 9-way 'D' type female connector

RS232 Connections Table

PIN No.	INPUT/OUTPUT	SIGNAL	STATE
1	Output	Data Terminal Ready (DTR)	Held High
2	Output	Transmit Data (TxD)	
3	Input	Receive Data (RxD)	
4	Output	Request To Send (RTS)	
5	Input	Clear To Send (CTS)	Active High
6	Output	Do not use	
7	Common	Ground	
8	Input	Do not use	



Note: Pin 6 and pin 8 should not be used.

1.6.5.1 RS232 Output

Connect the PC6-IDOS to a printer or computer using a suitable cable (not supplied) as detailed above and set the parameters as detailed in Para. 2.5 & 2.7. The output can now be obtained as 'single shot' or 'timed' as follows:

1.6.5.2 Single Shot - This output is always available in Display mode when RS232 status & Log status are OFF. The output is obtained each time the  key is pressed (provided any previous output is complete).



Warning: The PC6-IDOS must be switched off prior to connecting or disconnecting the RS232 cable.

1.6.5.3 Timed - This output is available in Display mode when RS232 status is ON & Log status is OFF. The output cycle is initiated by pressing the  key. Pressing the  key cancels the output. Once initiated, the output is repeated at the selected time interval (see 'Event' function, page 26) until the  key is pressed.

1.6.6 Battery Charger The internal battery pack may be recharged (when indicated by the battery low message) by plugging the charger (supplied) into the '9V' socket.

CAUTION: When recharging internal batteries, only the charging unit supplied with the PC6-IDOS should be used.

1.6.7 Voltage Output A voltage of +10V or +24V may be sourced from the PC6-IDOS by connecting to the 4 mm sockets. A typical application for this voltage output would be to power a pressure transmitter. (see Fig. 3. page 10)
To switch on voltage output function:-

- Press the  key twice to activate 'Set' menu.
- Select 'V-out' and press the  key.
- Select 'ON' and press the  key.

1.7 Messages & Parameters

The PC6-IDOS registers pressure input at switch on after the initial start-up message. The pressure reading is displayed on the top line of the LCD (see Page 3). Pressure values are monitored, alarm values are compared, alarm warnings and other information messages displayed until the unit is switched off.

Memory Errors:

Any read / write errors to memory detected at switch on will be reported as: Memory Error 'Error No.'

Error Numbers:-

0 - Onboard eeprom; **8** - RTC; **9** - 2nd Onboard eeprom.
Errors with Pressure Modules will be indicated by the message: "No P1 (or P2) Module" preceded by "PM EEPROM ERROR" at power on.

1.7.1 Retained parameters When switched on, the unit registers the same state as when last switched off. The display mode (Operating/Set), units of measurement, function and parameter settings, alarm limits and RS232 output control, Port (P1 or P2) selection, logged parameters are all retained at switch off, with the exception of the following conditions:

1.7.2 Battery low state A battery low state occurring prior to the switch off. When switched on, the unit registers the latest retained set of parameters.

1.7.3 Tare value Any TARE value set during use is not retained and therefore should be set, if required, each time the unit is switched on.

1.7.4 Maximum/Minimum Maximum and Minimum values are not retained. Current values reflect pressure monitored from the start of the pressure input.

1.7.5 Void leak test If the unit is switched off during a LEAK test then the test will be void. When switched on again the unit will start up in LEAK test mode.

1.7.6 Switch off When the  key is pressed the 'switch off' message is displayed for two seconds accompanied by an audible bleep. Normal operation may be resumed by pressing any key during switch off.

1.7.7 Auto Switch off The PC6-IDOS will automatically turn itself off after a set period (See Page 31 for instructions)

1.7.8 Pressure Overload (Bleep rate 4 Hz) 'OVERLOAD' occurs when input pressure exceeds overload pressure level.

1.7.9 Low Battery Detect (Bleep rate 1 Hz). 'Low Battery' occurs when internal battery pack drops below 5.5V. Message flashes for 4 seconds, after a further 30 seconds, low battery detection is re-enabled.

1.7.10 Pressure Switch State Change (Bleep rate 2 Hz)

Occurs in pressure mode with the pressure switch state display being selected. When the connected pressure switch changes state, the pressure value (upper line) is frozen and the pressure switch state (lower line) display is flashed at 1 Hz unless a log file is open. Normal display update resumes when the  key is pressed.

1.7.11 Printer Busy (Bleep rate 1 Hz)

If the receiving device is not ready for input (e.g. device not connected or handshake LOW), 10 seconds after starting an output cycle (single shot or timed output) the message 'Printer Busy' is flashed on the display, together with an audible warning. If the device does not accept input within the next 5 seconds then the output cycle is cancelled and output is stopped until the  key is pressed again.

1.7.12 Outside User Set Alarm Values (Bleep rate 2 Hz)



Occurs when measured pressure is lower than the user set Low alarm value or greater than the user set High alarm value and the 'outside limits' message is flashed. Indication ceases when pressure is equal to either alarm value or between the values.

1.7.13 Display Hold (Bleep rate 2 Hz)

Occurs in pressure mode. If the  key is pressed once (less than 1 second) the pressure value (upper line) is frozen and the lower line is flashed with the 'Display Hold' message at 1 Hz. Normal display update resumes when any top row key is pressed.

Note: The display contents can be printed out during display hold by pressing the  key.

1.7.14 Connection Fault:

In voltage / current source mode, if the PC6-IDOS is unable to control the voltage/current output (e.g. because there is no loop back in the current mode), the message "Connection Fault" will flash on the lower line accompanied by a beep at 1 Hz. The message will continue until the user presses the  or  key (after fault is rectified) or the user exits from source mode.

1.7.15 Short Detected:

If the 24V output is ON and it is shorted to 0V, the message "Short detected**" will be displayed on the lower line accompanied by a beep at 1 Hz. This message will be cleared after approximately 5 seconds. In this condition the 24V supply will be switched off for safety.

1.7.16 Voltage / Current Overscale:

In Voltage measure mode, if a voltage in excess of 55V is connected to the PC6-IDOS the message "OVERSCALE**" will be displayed on the lower line, until the voltage falls within the input limits.

In Current measure mode, if a current in excess of 55mA enters the mA terminal, the PC6-IDOS will display "OVERSCALE**" on the upper line and the lower line will scroll the message "Check connections: Press MENU to continue". Pressing the  key will remove the message provided the current measured is within range. This message may also appear in the source mode under connection fault conditions. Source mode will change to measure mode for safety.

If the current overscale message occurs when the PC6-IDOS is in timed RS232 output mode, the unit will exit from the timed output mode.

If there is an excess voltage at the mA input when the PC6-IDOS is placed into current measurement mode, the message "Connection Fault" will be scrolled on the lower line. Once the fault has been rectified, press the  key to return to measuring mode.

1.7.17 RS232 Output Format













The output format is as follows:
 LF
 Time & date (23:13:30 081100) +LF
 display top line (16 characters) + LF
 display lower line (16 characters) + LF
 alarm flag (1 character) + LF

1.7.18 Alarm Flags

A single character is output to indicate the various pressure alarm conditions as given below:
 * overload pressure level exceeded (pressure warnings, 1.7.8 & 1.7.12)
 > pressure exceeds user set high limit
 < pressure below user set low limit
 " " a space if no alarms apply.
 c connection fault
 s short detected

Note: If two (or more) conditions occur which require a message display, the highest priority condition in the above list will be displayed. The sequence of messages given above set the priority except 'Switch Off' which comes last.

1.7.19 Display Symbols†





	Log Status ON		Log Status ON File Open		Rs232 Output Status ON
	Pressure Port 1 selected		Pressure Port 2 (EPM) selected		
Top line symbols					
	Timed Log / output		Keyed Log / output		Source Step Mode
	Nudge Mode (UP)		Nudge Mode (DOWN)		Source Mode Ramp
Bottom line symbols					
	Measure Mode & P-V / P-mA		Root Function		

† If more than one symbol is applicable, they are displayed one after the other.

HOW TO SELECT FUNCTIONS (MENU 1)

1.8 Units





To change the units of pressure, proceed as follows:

- Press the  key once, then press  key to choose the units sub-menu
- Select required unit by pressing the  key and then press  key.

The display will indicate the pressure in the selected unit and the pre-selected 2nd line function.

1.9 Max., Min., Switch, Temp °C, Date & Time, %

To display any one of these functions, proceed as follows:

- Press the  key once and then scroll to the required function using the  or  key and then press  key to select it.

The display will show the pressure on the top line and the 2nd line will show the function that has now been selected.

For Max. & Min., the displayed values are based on a 60Hz update rate. However, since the upper line pressure value is updated every half a second, the Max./Min. values may not be seen here. Conversely, for switch, each time the switch changes state, the upper line pressure value is refreshed with the latest 60 Hz pressure value.

1.10 Tare:

The Tare value can be displayed on the bottom line by selecting 'Tare' from the menu using the  key and pressing the  key.

To activate **Tare** function: hold down the  key for 4 seconds while in the pressure display mode. The unit will bleep after two seconds when the Max. and Min. values reset. At four seconds another bleep will sound as the displayed pressure now resets to zero. This is a temporary function and will be cancelled when the unit is switched off.

1.11 V/mA (procedures are the same unless otherwise stated)

Two main options are available for 'V' and 'mA':-

- Select 'Measure' for V and mA input.
- Select 'Source' for V and mA output.



Select Measure
Source Exit

To measure input voltage or current select 'Measure' and press the  key.

Two options are now available; 'Actual' and 'Convert'.

- 'Actual' is selected by pressing the  key.



An example display below shows the Measure Mode symbol on the second line.



700.00 bar
→mV 100.000

- Select 'Convert' using the  key and press the  key. To setup the conversion parameters, i.e. zero, full scale or text; see 2.1 on page 22.





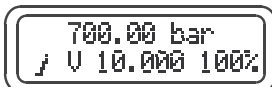

To output voltage or current:

- Select 'Source' using the  key and press the  key. Three options become available; 'Actual', 'Convert' and 'P → V' / mA.

- 'Actual' is selected by pressing the  key.

An example display below shows the Source Mode symbol on the second line.



- Select 'Converted' using the  key and then pressing the  key. To set the converted parameters refer to section 2.2.1 on page 23.
- Select 'P → V' /mA using the  key and then press the  key. To set the parameters for this Pressure to Volts / milliamps conversion refer to section 2.2.3 on page 23.
Note: An external pressure source is required.
- By pressing and holding the  key for more than two seconds whilst in 'Source Mode' you will activate a '**Nudge**' function allowing the source value to be increased or decreased, the longer you hold down the  or  key, the larger the nudge increments will be (see Page 25 for more information).

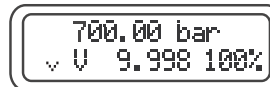



Note: NOT Available in Ramp or P-V / P-mA modes

By pressing and holding the  key again for more than two seconds, the nudge function will be cancelled.

1.12 Leak Test

To carry out leak tests, proceed as follows:

- Press the  key once and scroll to the 'Leak' function using the  key. Press  key to select.

Presented with the leak test sub menu, the options 'Start' and 'Set Time' are given as shown below.





Leak: Start
Set-Time Exit

Leak Sub-menu





1.12.1 Set Time

To set the duration of the leak test.

Scroll using the  key to select 'Set Time' and press the  key.





Leak: Start
Set-Time Exit

With the first digit now flashing, press  and then select the number required using the   keys and press  key. (e.g. time set to 999 min.)



Leak Test:
Duration 900Sec

With the second digit flashing, press  and again select the number required and press  key.



Leak Test:
Duration 990Sec

Repeat procedure for third number and press  key.

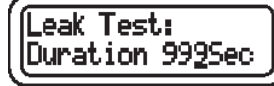

Leak Test:
Duration 999Sec

Now select the units of time measurement (e.g. seconds, minutes, hours, days, etc.) Scroll through the units with the   keys and press  key.

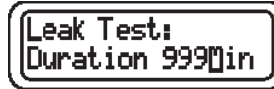

Leak Test:
Duration 999Min



Once the leak test time has been set press the  key to return to the leak test sub-menu.

- Select 'Start' using the   keys and press  key to start the leak test.



0.0000 bar
0.0000 999Min



The top line shows 0.0000 pressure and the bottom line shows the current pressure.

- Start the leak test by pressing the  key. The top line displays the difference in pressure while the bottom line shows the start pressure and the time counting down.
- When the leak test has finished, to start the leak test again press the  key once to reset the time and again to start the test.
- If no other leak test is to be carried out, press the  key to return to the leak test sub-menu.

1.13 File







This function allows the user to view, export, import and delete previously stored files.

To use the filing system proceed as follows:



- Switch the unit on.
- Press the  key once and scroll to 'File' using the  key and press .

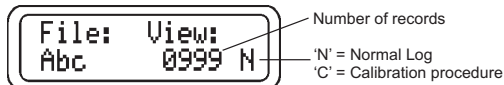

1.13.1 To view a file, proceed as follows:

- Select 'View' using  key and press .
- The latest filename is shown in the bottom left hand side of the display. The record count is shown in the bottom right hand side. To select this file press . If another file is required then scroll through the filenames using the   keys and then press  key.



- To move through the record now selected, press the  key or the  key. This will first show the 'IPM / EPM' serial number from which data was read.



- To view the following records in the selected file use the  or  key to advance to the next screen.

Date & Time →

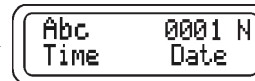

Pressure Data →

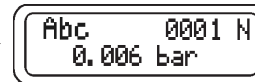

2nd line function →

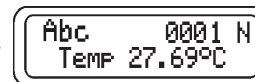



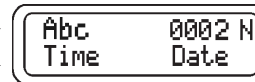

One Complete Reading

Next reading →



Time & Date →

Pressing the  or  key will enable the user to go through the records. Once the last record has been viewed an ****END**** message is displayed.





The records then 'wrap around' so the user can move to the first or last file record using the   keys.

Note: At the time of logging, if the pressure is above or below the set limits then a 'High' or 'Low' message will appear after the Pressure Data screen.



1.13 File (continued)

1.13.2 To Export a file, proceed as follows:



- Scroll the cursor using the  key and select 'Export' and press the  key.
- Select a file to export using the   keys and press the  key





```
File: Export:
Abc      0010 N
```

Note: When exporting to 'SiCal PRO' do not press enter after selecting the file.

1.13.3 To Import files, proceed as follows:

- Scroll to 'Import' using the  key. Once you have finished a calibration procedure in 'SiCal PRO', click on 'Export', press the  key on the PC6-IDOS to download. The message "downloading Cal" will be displayed. Once SiCal PRO gives "All done" message, press the  key
- Choose 'Yes' when prompted to 'Stop?'





1.13.4 To Delete files, proceed as follows:

- Scroll the cursor using the  key and select 'Delete' and press the  key.

The following options are available:



```
Delete: File All
Exit
```

- If you want to delete a particular file then select 'File' using the  key and then press the  key.
- Select a file to delete using the   keys and press the  key.





```
Delete: File:
Abc      0010 N
```

The unit will then display:





```
Delete: Sure?
Yes      No
```

If you are sure that the file is to be deleted then the 'Yes' option should be selected using the  key and then entered using the  key.

Once the operation is completed the display will return to the 'File' sub-menu.

If another file is to be deleted then repeat the procedure.

If no more files are to be deleted then press the  key to return to the pressure display.

Note: Pressing the  key once at any time during the procedure will take you back to the 'File' sub-menu.

If all the files in the PC6-IDOS are to be deleted then select 'ALL' in the Delete sub-menu and press the  key.

The following message is displayed:

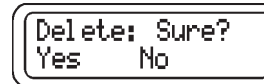

```
Delete: Sure?
Yes      No
```











- Select 'Yes' or 'No' and press the  key.

SET- MENU

(MENU 2)

2.0 Alarm settings 'High'/'Low'

To set High or Low pressure warning limits proceed as follows:

- Press the  key to switch on the PC6-IDOS.
- Select the 'Set' menu by pressing the  key twice.
- Select 'High' or 'Low' by pressing the  key and then press the  key.
- Select the digits to be set by moving the cursor with the   keys and pressing the  key.
- Set the number to the required value using the   keys and then press the  key.
- Repeat the previous two steps to change other digits for the alarm value.





- Once finished setting the alarm limit value press the  key to return to the pressure display.

A bleeping warning (2 Hz) and the 'Outside Limits' message will signal that the measured pressure is lower than the user set low alarm value or greater than the user set high alarm value. The bleeping ceases when the pressure is read between the two values.

Note: The PC6-IDOS will not allow pressure values to be entered greater than 5% above the maximum working range.

2.1 V/mA (Measure mode)

The PC6-IDOS can measure voltage or current and simply display it or convert it using the 'Converted, Setup' options and then display the measured value via a conversion factor.

- Select menu 2 by pressing the  key twice.
- Select V or mA by pressing the  key and then press  (e.g. mA is selected).
- The following options will appear, as shown below:









```
Select: Measure
Source Exit
```

- Select 'Measure' using the  key and press the  key



```
Zero FS Text
Root Exit
```

2.1.1 Zero:







- Select 'Zero' using the  key and then press the  key.
- Using the   keys and the  key, change the value of the converted zero. Press the  key to finish editing.



```
Measure Z. Conv.
004.000 000.000
```

e.g. 4.00 mA will be converted to 0.00 bar

2.1.2 FS (Full Scale):

- From the setup menu select 'FS' using the  key and then press the  key.
- As with the 'Zero' above, set the conversion factor for a full scale input using the   keys and the  key. Press the  key to finish editing.



```
Measure FS Conv.
020.000 010.000
```

e.g. Full Scale 20mA will be converted to 10 bar

2.1.3 Text:



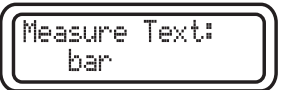

The 'Text' function is used for changing the displayed units when the 'converted' (see 1.11 on page 15) option is selected. If 20 mA is being measured from a device then this could be converted and displayed as pressure in bar for example.



```
Measure Text:
bar
```

(6 characters max.)

2.1.4 Root:

- Select 'Root' using the  key and press the  key.
- Select 'On' or 'Off' using the  key and press the  key. With 'On' selected, any measurements will be displayed having the root function applied until 'Off' is next selected.

Note: Due to display constraints, the six character 'Text' readout will be shortened to display the first three characters when the 'Root' function is switched on. 'Root' function is available in both Actual and Converted modes.

2.2 V/mA (Source mode)



Select: Measure
Source Exit

The second option for V and mA is 'Source' (output) mode.

- Select 'Source' using the  key and press the  key.

The following options are available:-



Source: Range
Convert P->V

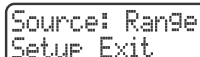









Source: Range
Setup Exit

2.2.1 Range: (sets the upper and lower limits in Source mode)

- Select 'Range' using the  key and press the  key.

The following options are available:- 'Zero' or 'FS'.















- 'Zero' is the first option, press the  key to select it.
- Change the value as required using the   keys and press the  key to enter.
- To alter the FS value, select 'FS' using the  key and press the  key.
- Change the value as required using the   keys and press the  to enter.

Note: The 'Zero' and 'FS' values have been limited with respect to each other as follows:

















- The lower range is limited to between 0 and the user's upper range minus 1% of the maximum source range available (e.g. 10 V or 50mA).
- The upper range is limited to between the lower range plus 1% of the maximum source range and the maximum source range available.

2.2.2 Convert:

To set up conversion factors for Zero, Full Scale or a user defined (Text) value.

- Select 'Zero' by pressing the  key.
- Change the zero conversion values as required using the   keys and the  key.
- Select 'FS' (full scale) using the  key and press the  key.
- Change the 'FS' conversion values as required using the   keys and the  key.
- Select 'Text' using the  key and press the  key.
- Select a three letter or number text value using the   keys and the  key.
- Once you have completed altering any or all of the convert functions select 'Exit' or press the  key to return to the 'Source' menu.

2.2.3 P->V / mA: To setup a pressure to voltage / current conversion

- Select 'P->V/mA' using the  key and press the  key.
- For 'Zero', press the  key to enter.
- Change the V / mA value as required using the   keys and the  key.
- Change the pressure value as required using the   keys and the  key.
- Select 'FS' using the  key and press the  key.
- Change the V / mA value using the   keys and the  key.
- As with the 'Zero', change the pressure value as required using the   keys and the  key.

2.2.4 Setup: Sets the parameters for V / mA sourcing

2.2.4.1 Status:

- Select 'Status' using the  key and press the  key.
- Select 'Off' or 'On' and press the  key.





2.2.4.2 Root:

When switched on, this provides a voltage or current output with the application of square root function.

- Select 'Root' using the  key and press the  key.
- Switch the function 'Off' or 'On' using the  and  key.

2.2.4.3 Step: (Not available in P to V / mA mode)

To set the voltage or current output increments (%FS):

- Select 'Step' with the  key and press the  key.
- Change the value as required using the  and  key.

2.2.4.4 Ramp: (Explained on Page 25.)

To set the 'Status', 'Rate' and 'Dwell_time' proceed as follows:-



2.2.4.4.1 Status

- Select 'Status' by pressing the  key.
- Select 'Off' or 'On' using the  key and press the  key

2.2.4.4.2 Rate

- Select 'Rate' with the  key and press the  key.
- Change the V/sec or mA/sec value using the   keys and press the  key.

2.2.4.4.3 Dwell_Time

- Select 'Dwell_time' with the  key and press the  key.
- Change the time if necessary using the   and  keys..

Ramp Mode: (Not available in P to V / mA mode)

Ramp mode consists of two parts, a ramp and level. The 'Step' and 'Range' (zero and full scale) determine the values for voltage / current at each of the levels (see Fig.4).

Rate is the Ramp rate or increments in V/sec or mA/sec.

Dwell_time is the time for which the output (source) stays on each level, when the Dwell_time has expired the output will ramp to the next level.

With the Ramp status on, the unit will operate in Ramp Mode, with the Ramp status off, the unit will operate in Step Mode (using the same steps as the Ramp Mode but with no ramping between levels). In Step Mode, pressing the ▲ or ▼ key will cause the output to increase or decrease to the next level. In Ramp Mode, the ▲ key will start the ramping, the ▼ key will return the unit to Measure Mode.

Pressing the ▲ ▼ together for one second returns the Ramp Mode to its starting point. In Step Mode, pressing the ▲ ▼ Keys together returns to the first Step level.

To enter 'Nudge Mode' (where the output increments in smaller steps) press and hold down the MENU key for two seconds (operates in source 'Step Mode' only). The unit will beep to indicate that the Nudge Mode has been activated. In Nudge Mode the source symbol changes to either ■■■■ or ■■■■ depending upon the nudge direction. To exit from

Nudge Mode press and hold the MENU key for 2 seconds

Nudge increments are as follows:

mA range = 1uA

Lower V range = 0.2mV (up to 5.5V)

Upper V range = 2mV (5.5 to 10V)

If the ▲ or ▼ key is held down for more than 4 seconds the nudge increment is increased by a factor of 5 accompanied by an audible beep every 2 seconds whilst either ▲ or ▼ key is pressed until the user's end limits are reached.

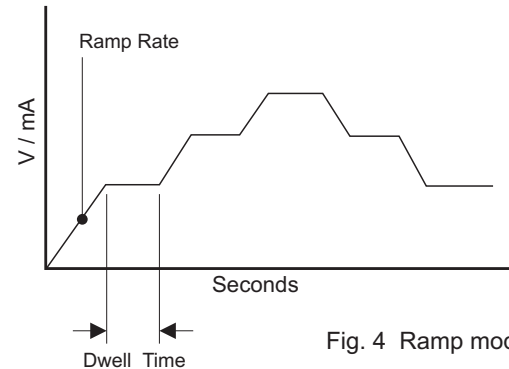









Fig. 4 Ramp mode.

2.3 V-out, Display Light







These functions may be selected as follows:

- Switch on PC6-IDOS.
- Press the  key twice to select the Set menu.
- Select the required function using the   keys and then press the  key. Each of these functions has an On or Off setting.
- Select the setting using the  key and then press the  key.

Note: The display light can also be set On or Off by holding down the  key for more than 2 seconds. The display light status is retained at power-off.



2.4 Resolution

To change the resolution proceed as follows:

- Press the  key twice to select the Set menu.
- Select 'Resolution' using the   keys and press the  key.
- Select the required resolution (Low, Normal or High) using the   keys and then press the  key.

Note: Resolution will change by a factor of 10.

2.5 Event

- Press the  key twice to select the Set menu.
- Select 'Event' using the  key and then press the  key. The Event menu is shown below:



```
Event: Key Timed
Exit
```

2.5.1 Key:

This results in RS232 (status ON) output / data storage triggered by key press.

- Select 'Key' using the  key and then press the  key.









2.5.2 Timed:

This results in RS232 (status ON) output / data storage at fixed time intervals set by the user.



- Select 'Timed' using the  key and then press the  key.



```
Event: Timed:
Every 001Sec
```

- Select the digit to be modified using the  key and press the  key. Use the   keys to change the value and press the  key.
- Repeat for next digit and press the  key.
- Change the time measurement units in the same way and press the  key.
- Press the  key to return to the pressure display.



2.6 Log

- Switch on PC6-IDOS.
- Press the  key twice, scroll to and select 'Log' and press .

The display gives the option to log a file, view a file or change the log status as shown below:



2.6.1 Log:

- Select 'Log' using the  key and then press the  key.
- Presented with the sub-menu, enter a filename and record count if no files are present, or select a file to log into.

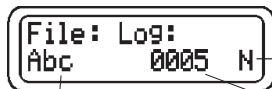







'N' = Normal Log
'C' = Calibration procedure log (requires 'SiCal PRO' software) *

filename

record count

To enter a filename: (max. 8 characters)

- Using the   keys, move to the filename position and press the  key.
- Select the characters/numbers to be used to name the file by scrolling up or down at each position and press the  key when completed.
- Press the  key to move on to the record count.





- As with the filename, define the record count and then press the  key when completed.
- If a file has already been set up with the same name then the 'Overwrite' option screen will be displayed.



- Start logging by pressing the  key. (see 2.5 'Event' on page 26).



The  symbol will appear to show file is open.

2.6.2 View:



- Select 'View' from the log menu using the  key and then press the  key.
- Select the file to view using the   keys and then press the  key.

* Please see Appendix 2, page 58 for details of Calibration Procedures.

2.6 Log continued

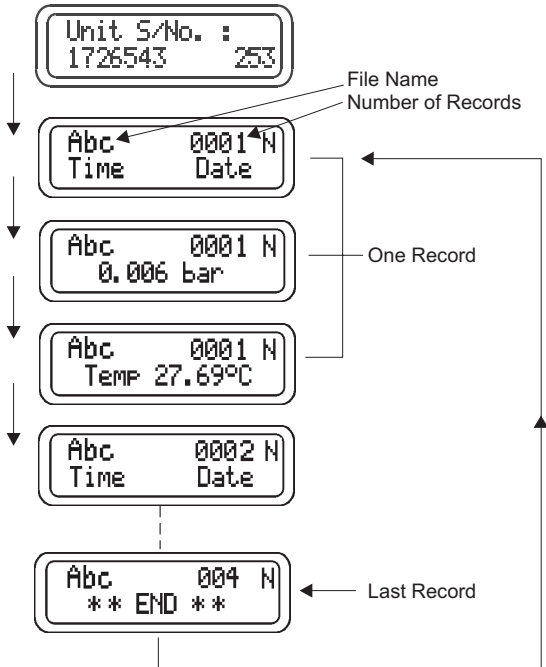
- With the file now selected, use the  or  key to show the file contents in the sequence shown below.







Note: Use the  or  key to scroll the other way. The direction in which the scrolling moves when using the  key depends on the last key pressed.

Press  twice to return to the 'Log' menu.





2.6.3 Delete:

To delete a logged file, proceed as follows:

- Select 'Delete' from the log menu using the  key and then press the  key.
- Select 'File', 'All' or 'Exit' using the  key and then press the  key.



Delete: File All
Exit

2.6.3.1 File:

- Using the   keys, select a file and then press the  key.
- A confirmation to delete file prompt is given. Select 'Yes' or 'No' and then press the  key.



Delete: Sure?
Yes No

2.6.3.2 All:

- Select the 'All' option using the  key and then press the  key.
- A confirmation to delete all prompt is given. Select 'Yes' or 'No' and then press the  key.

All Files stored on the PC6-IDOS will be deleted.



2.6.3.3 Exit:

- Select the 'Exit' option using the  key and then press the  key.

2.6 Log (continued)

2.6.4 Status:

Use this option to enable or disable logging function.

- Select 'Status' from the log menu using the  key and then press the  key.

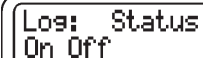

```
Log: Status
On Off
```

- Select 'On' or 'Off' and then press the  key.
- The display returns to the log menu.

Once a file has been set using the instructions given, the logging process is shown as active with a disc shaped icon in the top left hand corner of the display.

If you should press the  key whilst logging is in progress then the following screen appears:

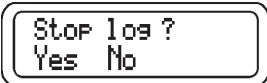

```
Stop log ?
Yes No
```

Select 'Yes' or 'No' and then press the  key.



Note: Pressing the  key allows direct access to the log menu. This is only possible if the log status icon is flashing in the top left hand corner of the display.

2.6.5 Export and Import:

See 1.13.2 and 1.13.3 on page 19 for *Export* and *Import* procedures.

2.7 RS232



RS232 standard communication protocol is available on the PC6-IDOS. Select the RS232 functions as follows:

- Connect the PC6-IDOS to a printer or computer as described in paragraph 1.6.5 on page 11.
- Switch on PC6-IDOS.
- Select the Set menu by pressing the  key twice.
- Select 'RS232' option using the  key, then press the  key. The RS232 menu is displayed as below:







```
RS232: Status
Baud-rate
```





2.7.1 Status:

- Select 'Status' using the  key. Choose 'On' or 'Off' option with the  key and then press the  key. The display returns to the RS232 menu.

2.7.2 Baud Rate:



- Select 'Baud-rate' using the  key and then press the  key. Select the required baud rate (1200, 2400, 4800, 9600, 19200 or 38400) using the   keys and then press the  key.

2.7.3 Stop Bits:

- Select the 'Stop bits' using the  key and then press the  key. Select either 1 or 2 bits with the   keys and then press the  key.

2.8 Date & Time

To select Date & Time proceed as follows:

- Switch on PC6-IDOS.
- Press the  key twice to select Set menu.
- Select 'Date & Time' option using the  key and then press the  key.









Date&Time: Set
View Exit

2.8.1 To set the time:



- Select 'Set' using the  key, then press the  key.





Set: Time Date
000000 000000

- Select the digit you want to change using the  key and press the  key. Use the   keys to change the value and then press  key.
- Repeat the above step to change the other digits to set time and proceed to the next set of digits to change the date.
- Press the  key to return to the 'Date & Time' menu.

2.8.2 To view date & time:

- Select 'View' using the  key and then press the  key.
- Press the  key to return to the Date & Time menu.

2.9 Language

- Press the  key twice.
- Scroll to 'Language' using either arrow key and press  key to select.



Language: English
German Exit



- Select the desired language from the options provided and press the  key.

Note: To download different languages, see 3.2 on page 35.

2.10 Zero (for absolute transducers, please see page 31)

Note: Unlike the 'Tare' function (page 15), 'Zero' reset is a permanent setting.

To reset pressure reading to zero:

- Press the  key twice to select the Set menu.
- Select 'Zero' option using the  key and then press the  key.



** ZERO RESET **
Press Enter

- Press the  key as instructed.





The Pressure Display will now show the pressure value as zero. If however the pressure reading is not within 5% Full Scale the following message will be displayed and the zero reset will not be possible.



** TOO LARGE **
No Change-Press

For absolute transducers it is possible to adjust the pressure reading at barometric pressure. This function should only be performed when there is access to a high accuracy barometer, and both the barometer's and PC6-IDOS's pressure sensing ports must be at the same height. *The pressure reading can only be altered by up to ±5% of Full Scale pressure.*

To adjust the barometric reading of an absolute transducer, proceed as follows:

- Select the zero function as described on the previous page.
- You will now be presented with the current barometric pressure reading. When the pressure has stabilised, press the  key.
- The upper line display is the current pressure reading; the lower line display is the desired pressure reading.
- Adjust the lower line pressure value using the   keys and the  key. Once you are satisfied with the pressure value, press the  key.
- Provided that the desired change is acceptable, the adjustment will be performed, and you will see the message:







*** ZERO RESET ***
Press Enter

2.11 Port

This function allows the user to select the current (displayed) pressure module.

- Press the  key twice to select the Set Menu.

- Scroll to 'Port' using the  key and press the  key
- Select a module using the   keys and press the  key to activate. When selecting a different pressure module, the serial number and range of the module will be displayed briefly before the unit returns to pressure display.

2.12 Power_Off

The PC6-IDOS has an auto-power off function. The time after which the unit automatically switches off is adjustable from 1 to 999 minutes. However, the auto-power off will not operate under the following conditions:







If a key has been pressed during the auto-power off time period.

If a leak test is running.

If the RS232 Status is On.

If the Log Status is On.

If the unit is online with SiCal PRO.

- Press the  key twice.
- Scroll to 'Power_Off' function using the  key and press the  key.
- Select 'Key' to turn the auto-power function off.
- Select 'Timed' to set the auto-power off time (in minutes) and press the  key. This automatically turns the auto-power function on.
- Set to desired time using the   keys and press the  key.

CAL-MENU (MENU 3)

Important note:

Should you wish to change zero or span settings at any time, the original calibration made at time of manufacture by GE will no longer apply. We therefore take no responsibility for any false or inaccurate readings that occur after any changes to span have been made. If the temperature of the pressure sensor is outside the range of 10 to 30 °C (50 to 86 °F) it will not be possible to perform the span operation.

Calibration Procedure:

If necessary then the span calibration should be made using a deadweight tester with an accuracy of 0.01% of reading or better, and carried out in a temperature controlled environment at 20 ± 2 °C (68 ± 3.6 °F).

To maintain the accuracy of the calibrator, do not increase the value of 'tol-ppm' above 50 (see flow charts).

For full calibration which includes Temperature Compensation between 0-50 °C (32-122 °F) the PC6-IDOS should be sent back to GE.

To access the Cal Menu, press all four top row buttons at the same time. A beep will accompany this action. Press the  key three times. The functions available are as follows:



Note: Password

To gain access to the 'Span' and 'Units' functions, you will be asked to enter a password. Enter the four-digit serial number located on the label on the rear panel of the unit.

3.0 Span:







Note: It is only possible to adjust the zero/span from the original calibration by up to $\pm 5\%$ of the unit's full scale range.

To set span:

- Select 'Span' using the  key and press the  key
- Enter the password, press the  key and choose "Continue"
- A 'Warming up...' message will be displayed for several seconds. The current temperature will be displayed on the lower line.
- The following screen will then be displayed asking you to set a tolerance.



The "Tol_ppm" figure is the pressure stability expressed as ppm of pressure reading

- If you want to change the tolerance value displayed then press the  key to select the first digit.
- Using the   keys, change the first value and then press the  key to enter it. The next digit will then be selected. Press the  key and change the digit as described above.
- Do the same for the third digit if required and then finish by pressing the  key once more.
- If however the value shown does not need to be changed then press the  key to continue.

You will now be asked to choose the number of calibration points (either 2 or 3). If two are chosen, by default, a zero point and a full-

scale point will be used for the subsequent zero/span. If three points are chosen then, by default, a negative pressure value, a zero point and a full-scale pressure value are used. The following example assumes that 3 points have been chosen for a gauge transducer.

- The following screen is then displayed:



You can now enter the value of the first pressure point that you wish to apply. After you have entered this value, apply the desired pressure and press the  key. You will now see the following screen:





- Select Yes and the unit will now take fifty readings.
- The following screen is now displayed:



- Provided the readings are within tolerance and 5% of the desired pressure value the unit will move to the next point.

The sequence for the first point will now be repeated for the 2nd and 3rd pressure points.

Once all the desired pressure points have been accepted the adjustment will be performed. The message "COMPLETED" will then be displayed. Press the  key to finish and return to the 'Cal menu'.

Notes: If at any time during the procedure you wish to exit and return to the 'Cal menu' then press the  key. The message: 'Sure ? No Yes' appears. Select 'Yes' to exit or 'No' to continue with the zero/span calibration.

Absolute: For absolute units, the following default pressure values will be chosen for a 2 point calibration:

Point:	Pressure value:
1	current reading
2	full-scale

For a 3 point calibration, the following default pressure values will be chosen:

Point:	Pressure value:
1	current reading
2	midpoint between 1st point and full-scale
3	full-scale

For the first point, you will be presented with the following screen:





1.0000 bar
Press ENTER to c

The current pressure value is displayed on the upper line. Once you have set up the desired pressure point and the pressure is stable, press the  key and you will see the following screen:



1.0000 bar
Set: _1.0500

This displays the last pressure reading (from the previous screen) on the top line and on the second line you can set the corrected value.

Set the required value and press the  key. Select 'Yes' or 'No' at the next screen and press the  key. The procedure for the remainder of the pressure points on an absolute transducer is identical to that for a gauge transducer.

Pressure point limitations:

For both gauge and absolute transducers, the pressure point values are limited as follows:

Gauge transducers, all points:

>= -1 bar (-15 psi) and < 105% full-scale pressure

Absolute transducers, all points:

>= 0 bar (0 psi) and < 105% full-scale pressure



Additionally, pressure points must lie in the following order:

Point 3 > Point 2 > Point 1

3.1 History:

- Press the  key to view the sub-menus.

3.1.1 Overload:







- To view the overload history move the cursor to 'overload' and press the  key. The display will show the cumulative time since the unit was last calibrated as in the example below:
- Press the  key to return to the 'cal menu'.

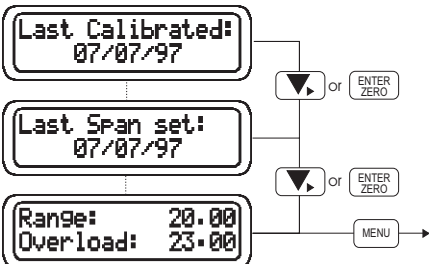

3.1.2 Span:

- To view the last zero calibration date move the cursor to 'zero/span' and press the  key.



- As shown above, the last calibration date is displayed first.
- Pressing the  or  key takes you to the next screen showing the 'last span set' date.
- Pressing the  or  key again the display shows the range of the unit and the overload setting.
- Press the  key to finish.
- Press the  key to exit to pressure display mode.

3.1.3 PC6-IDOS Serial Number:

- To view the unit's serial number move the cursor to 'PC6S/No' and press the  key.

3.1.4 Pressure Module Serial Number:

- To view the serial number of the selected pressure module, move the cursor to "PM_S/No" and press the  key. The accuracy of the sensor will be displayed on the lower line.



3.2 Language: (separate PC software utility needed - contact supplier)

To download different languages:-





- Connect PC6-IDOS to PC via the RS232 cable.
- Scroll to 'Language' and press the  key to select.
- The PC6-IDOS will display a 'DOWNLOADING' message until language download is complete.

3.3 Units User-defined unit conversion factors and the text associated with them:-

3.3.1 View:

- Select 'Units' using the  key and press the  key.
- Select 'View' by pressing the  key.
The first user-defined unit will now be displayed with the text on the upper line and the conversion factor on the bottom line. Pressing any key will display the next user-defined unit.

3.3.2 Alter: (to modify the user-defined units)

- Select 'Alter' using the  key and press the  key.
- The text for the user-defined unit is modified first using the  and  key.
- Press the  key when finished.
- Now modify the conversion factor as above. The conversion factor is the number of user-defined units per bar.

Repeat process if required for the second user-defined unit.

Note: To prevent confusion, it will not be possible to enter text for a user-defined unit that is identical to a factory-set unit in the PC6-IDOS. Additionally, the maximum value for the conversion factor is 100,000.

FLOWCHARTS

Menu 1 display menu

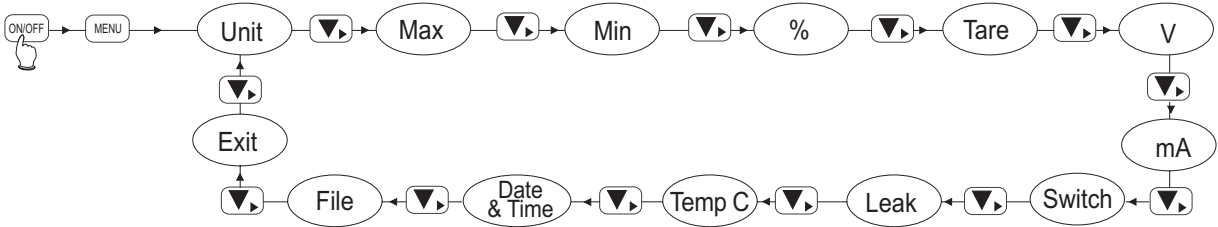

Menu 2 set menu

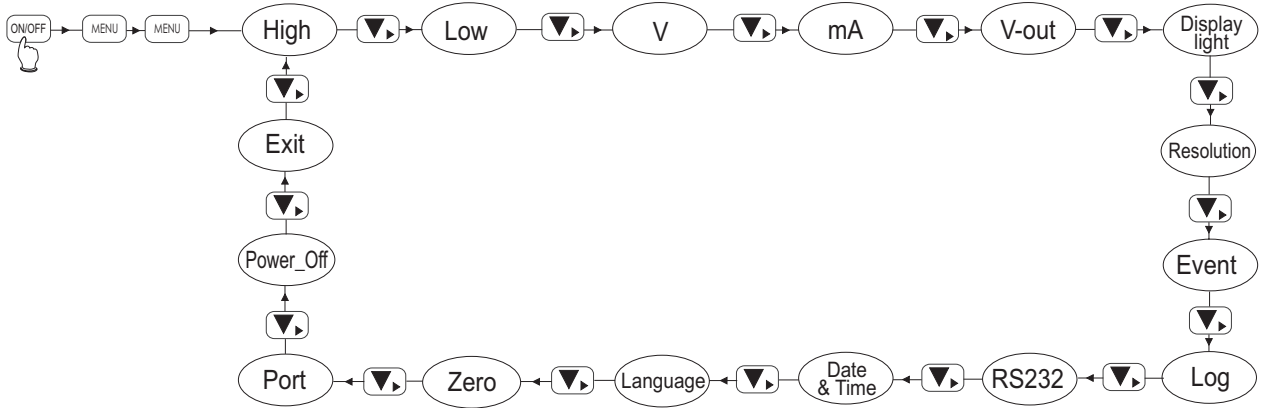

Menu 3 cal menu

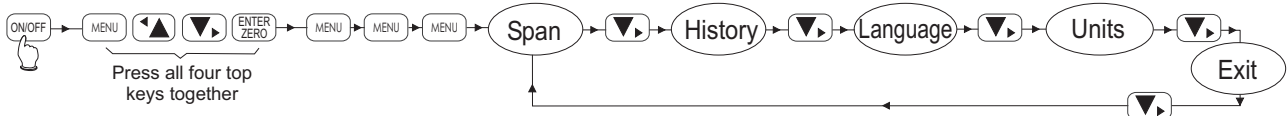

Menu 1 sub-menu Unit & Leak

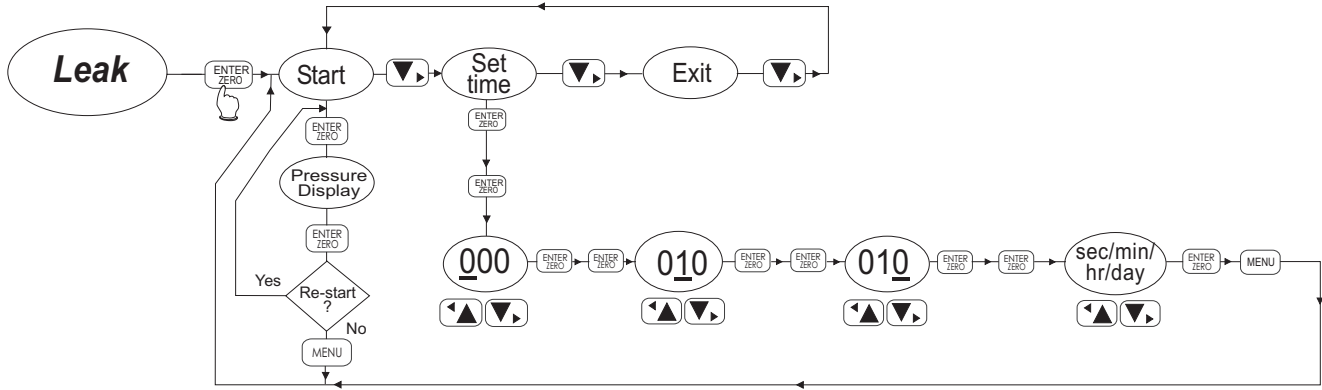
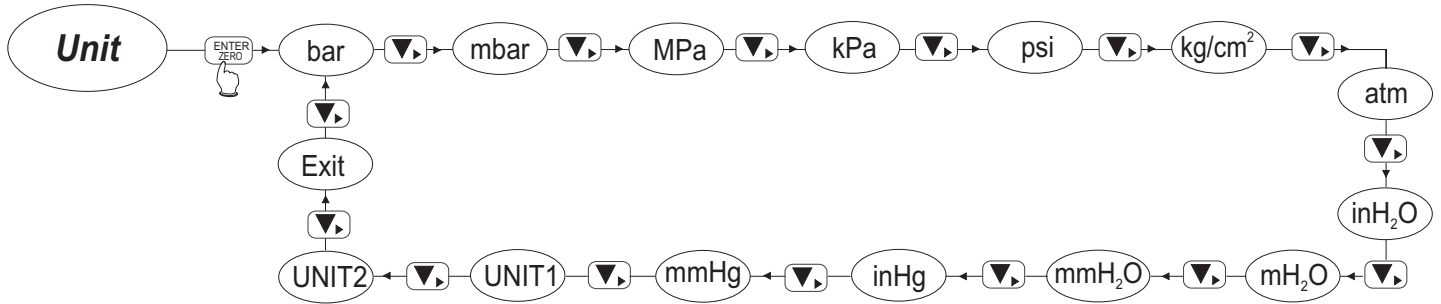

Menu 1 sub-menu V/mA

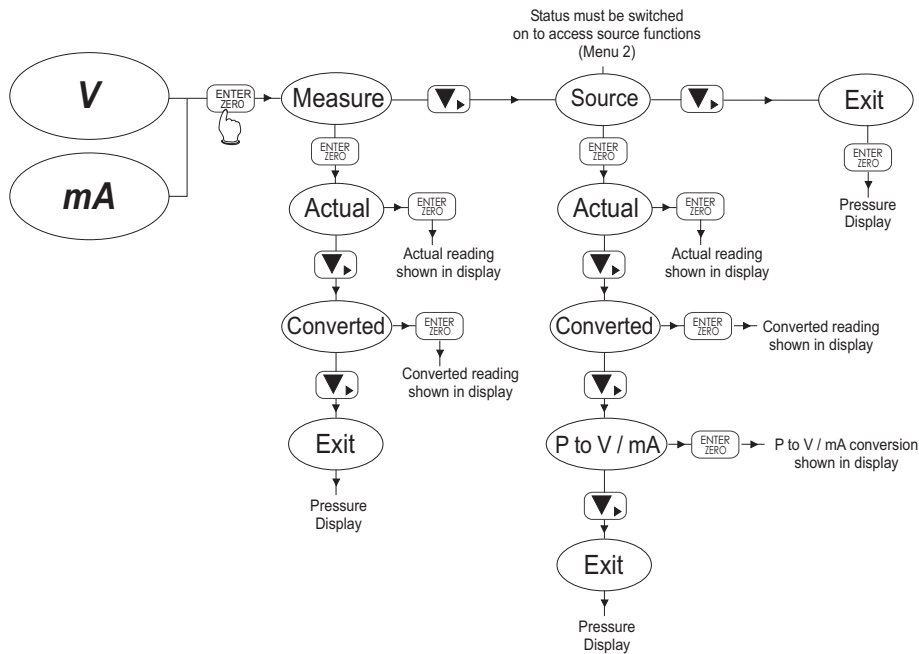

Menu 1 sub-menu File

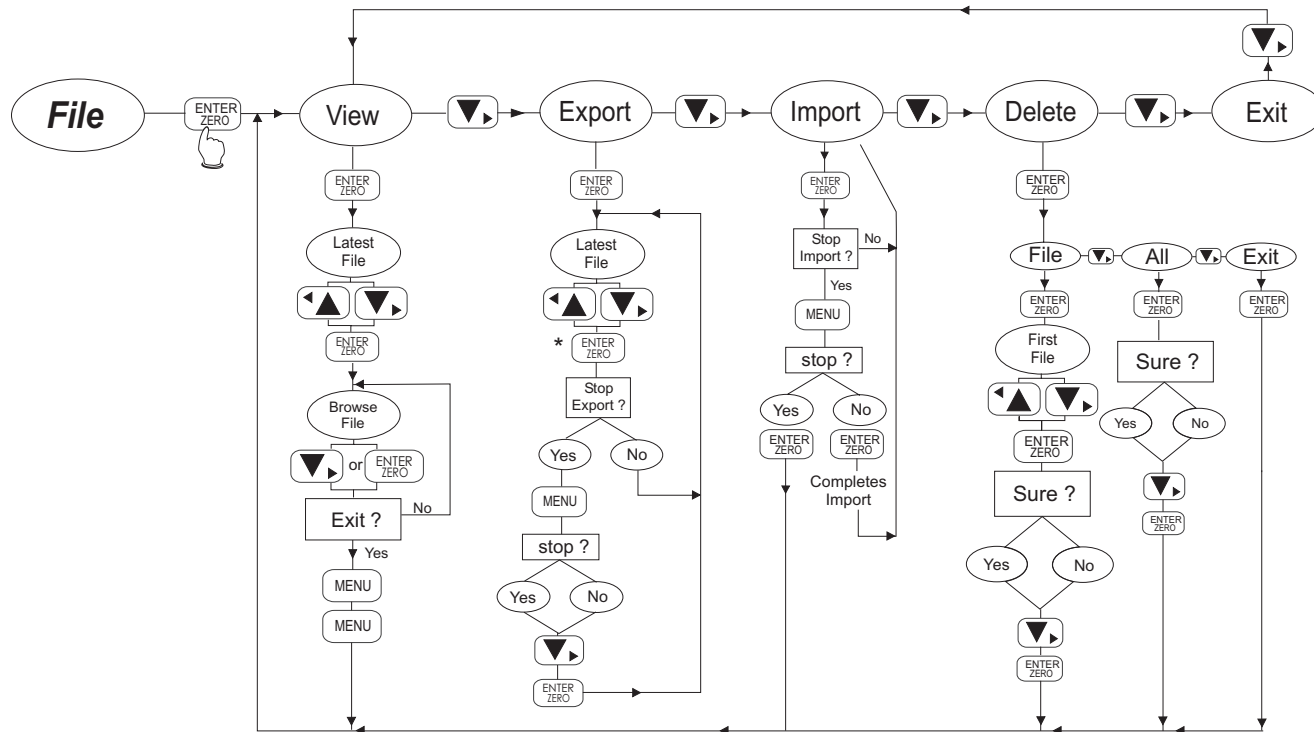

* ENTER ZERO not necessary for file export to 'SiCal PRO'.

Menu 2 High & Low

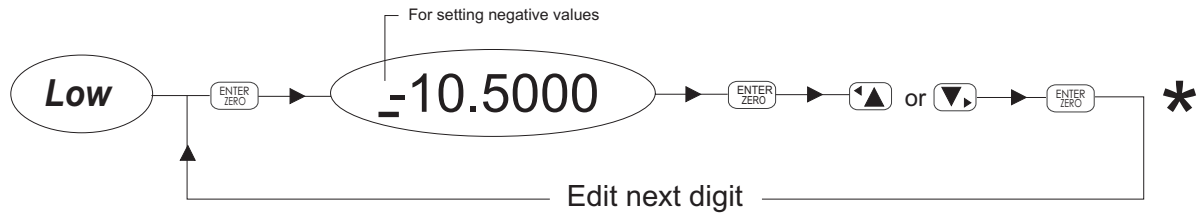
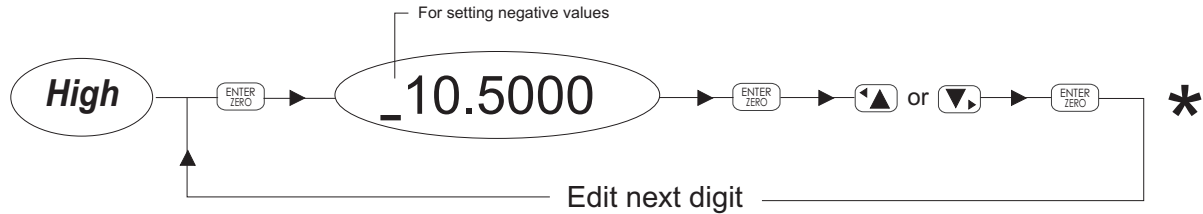

*** Once finished editing, press the  Key to go back to Pressure Display**

Menu 2 sub-menu V/mA (Measure)

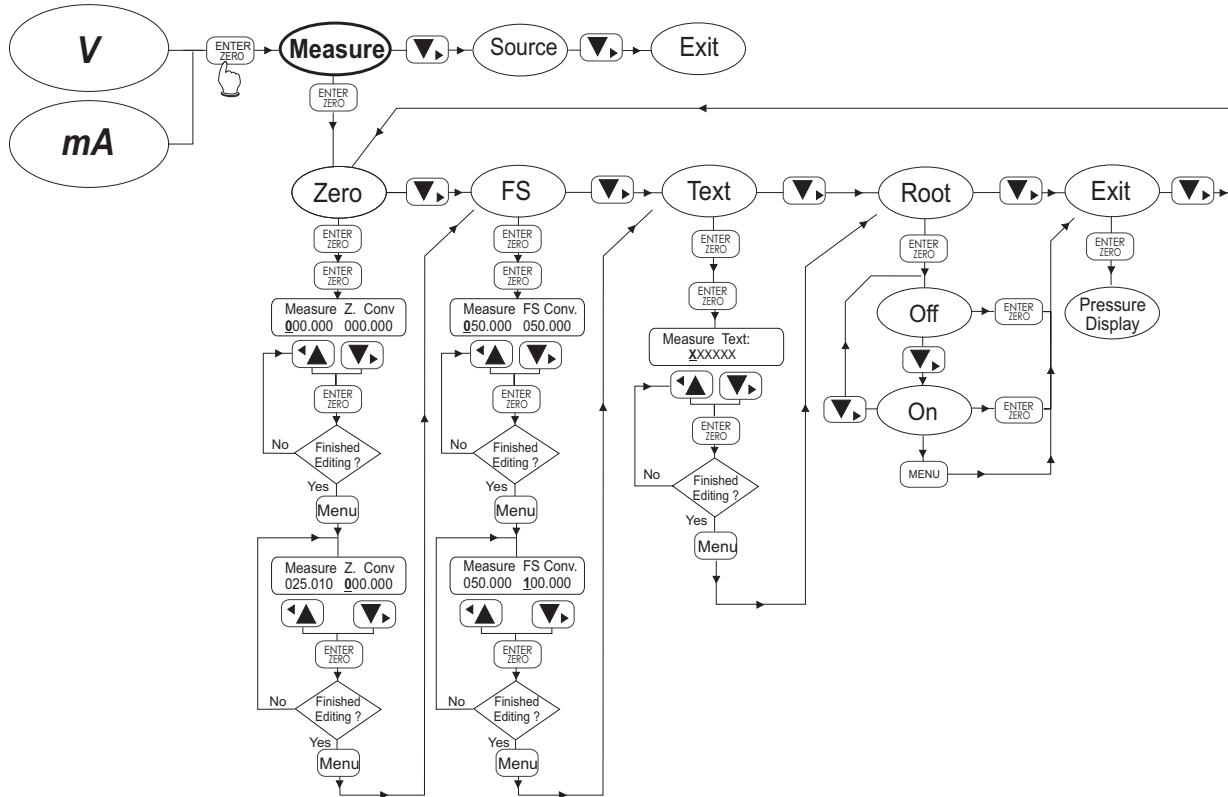

Menu 2 sub-menu V/mA (Source - Range)

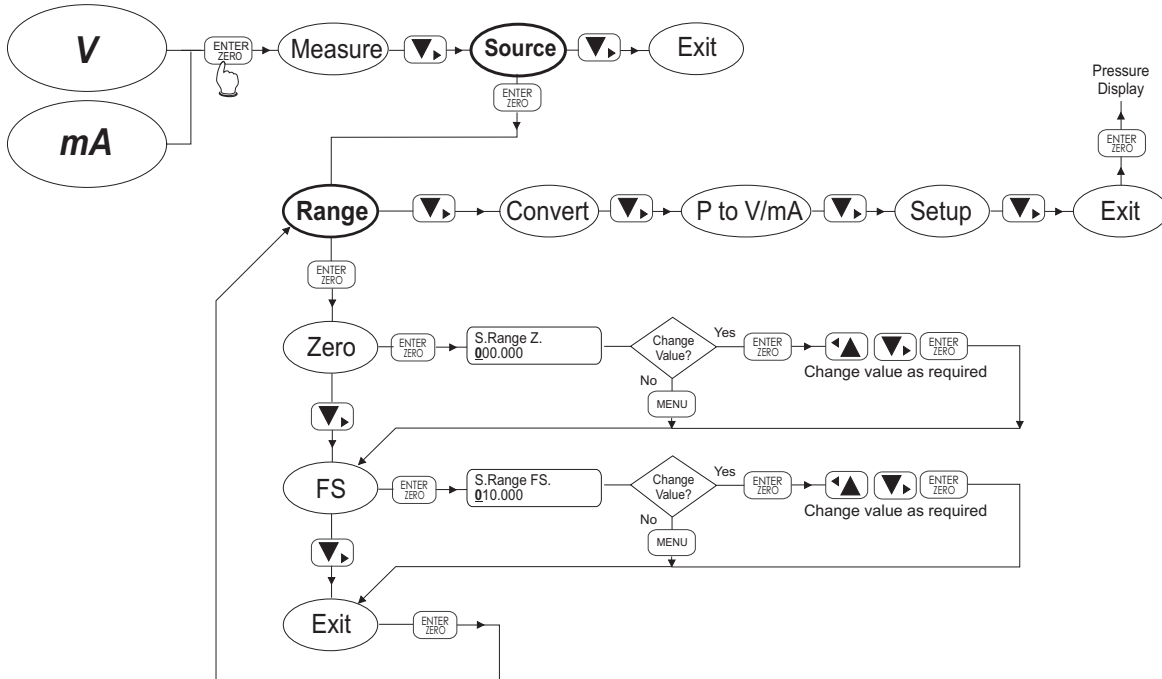

Menu 2 sub-menu V/mA (Source - Convert)

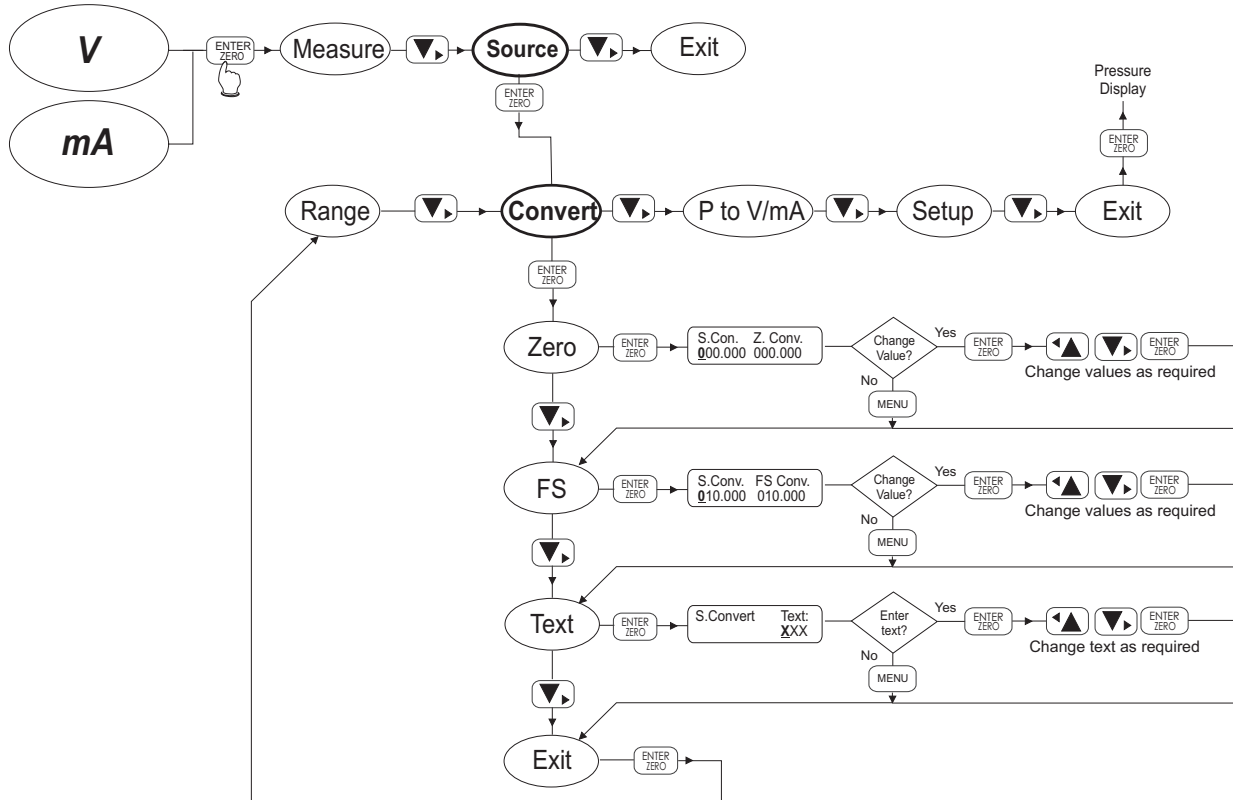

Menu 2 sub-menu V/mA (Source - P to V / mA)

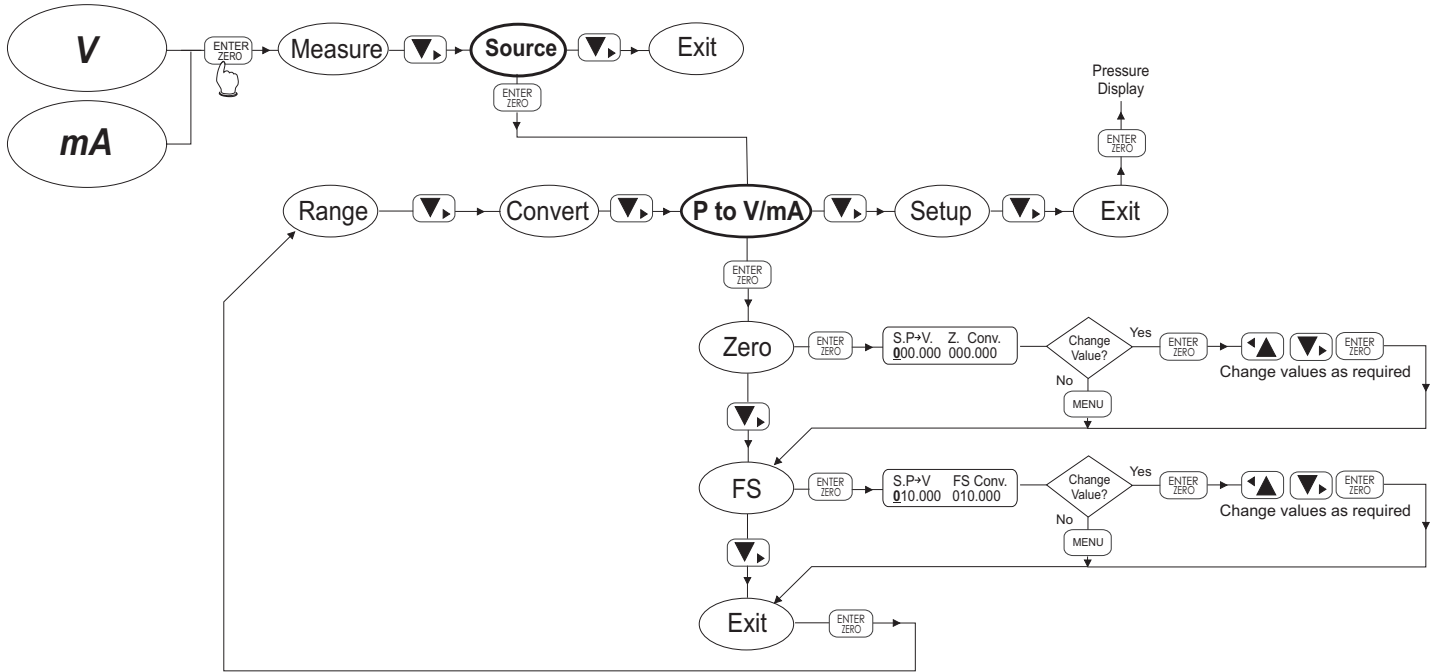

Menu 2 sub-menu V/mA (Source - Setup)

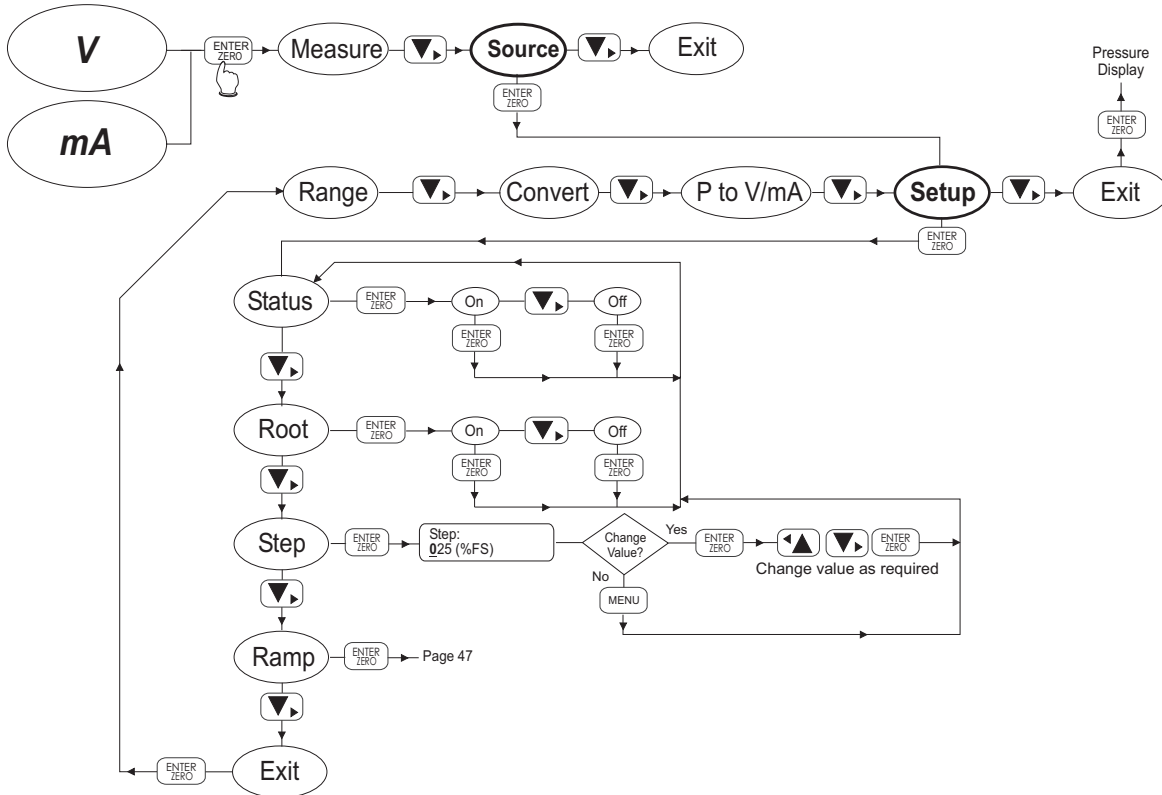

Pressure Display
ENTER ZERO

Menu 2 sub-menu V/mA (Source - Setup - Ramp)

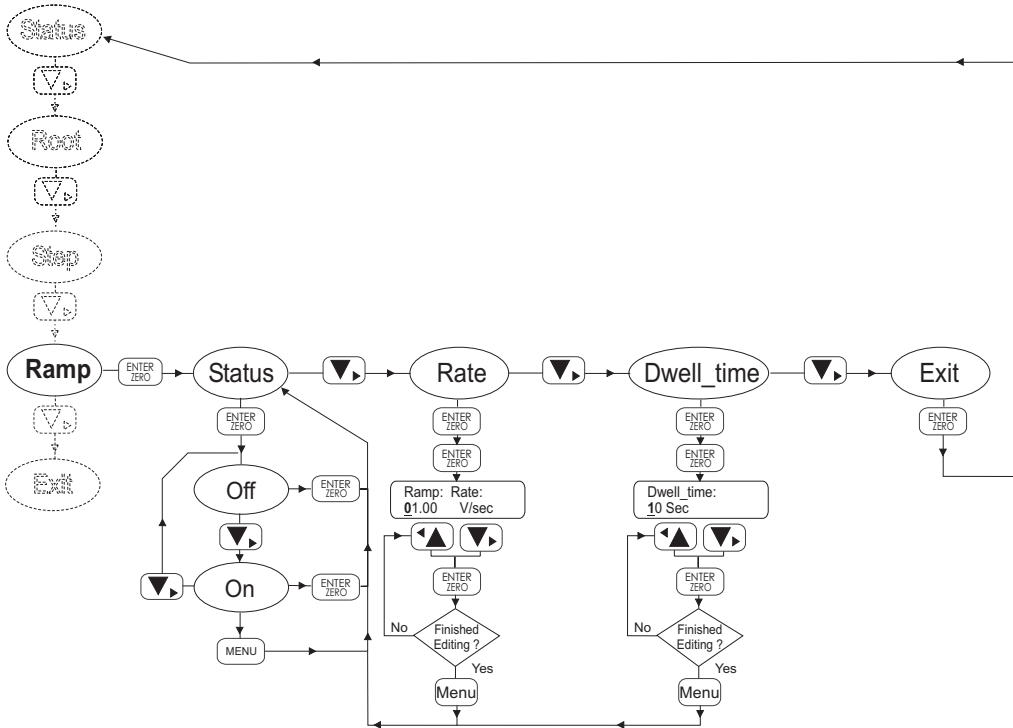

Menu 2 sub-menu V-out, Display light, Resolution, Event & RS232.

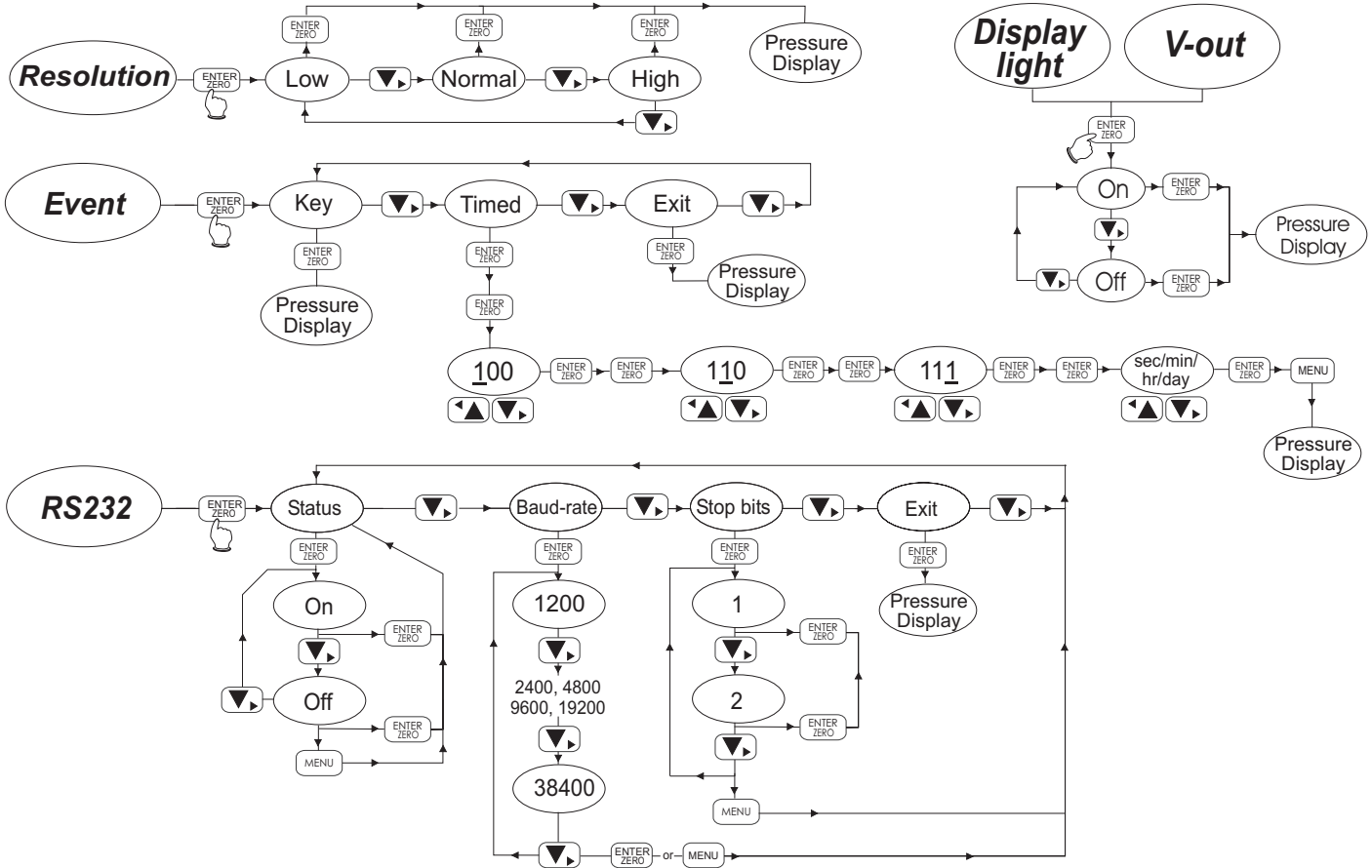

Menu 2 sub-menu Log

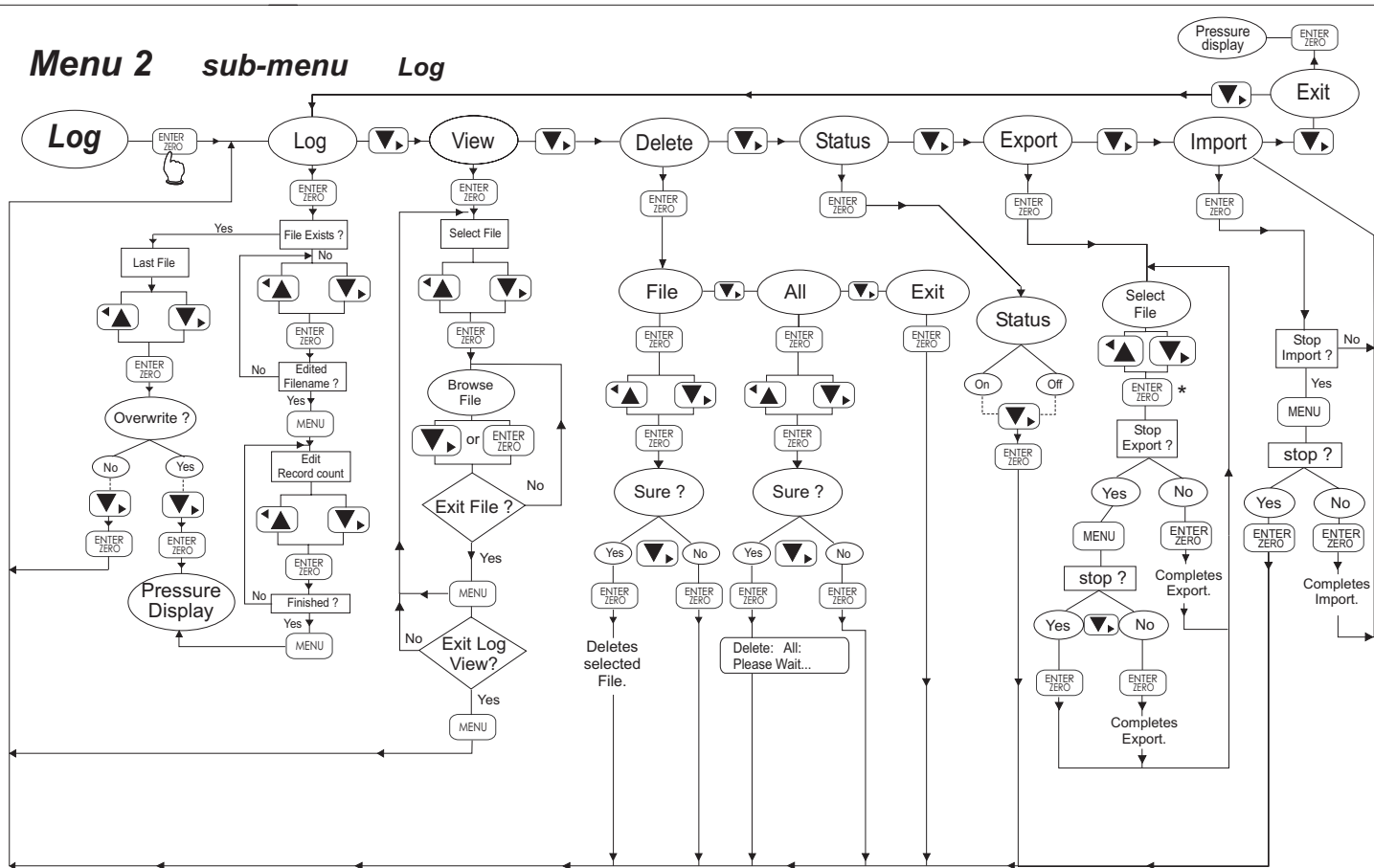

* ENTER ZERO not necessary for file export to 'SiCal PRO'.

Menu 2 sub-menu Date&Time , Language, Zero , Port, Power_Off

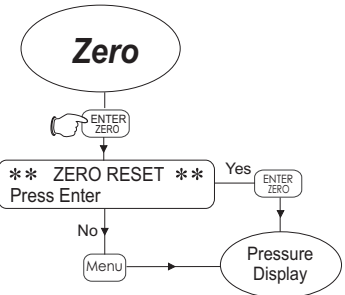
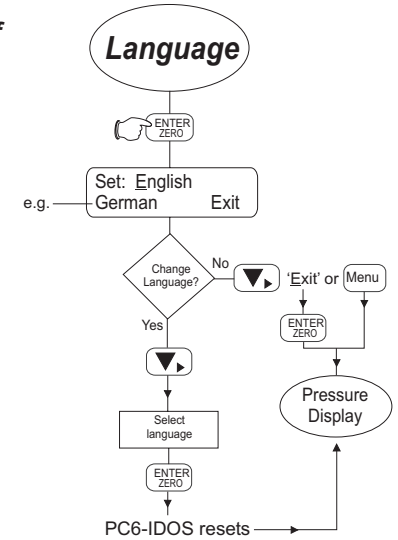
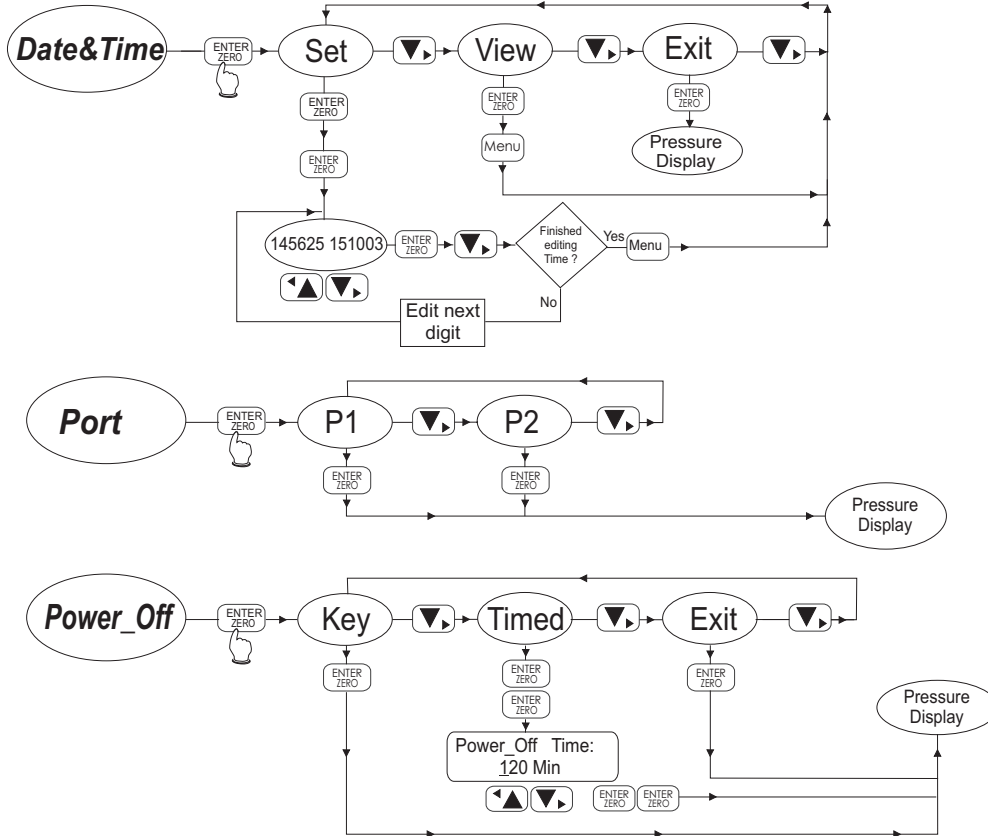

Menu 3 cal-menu Span

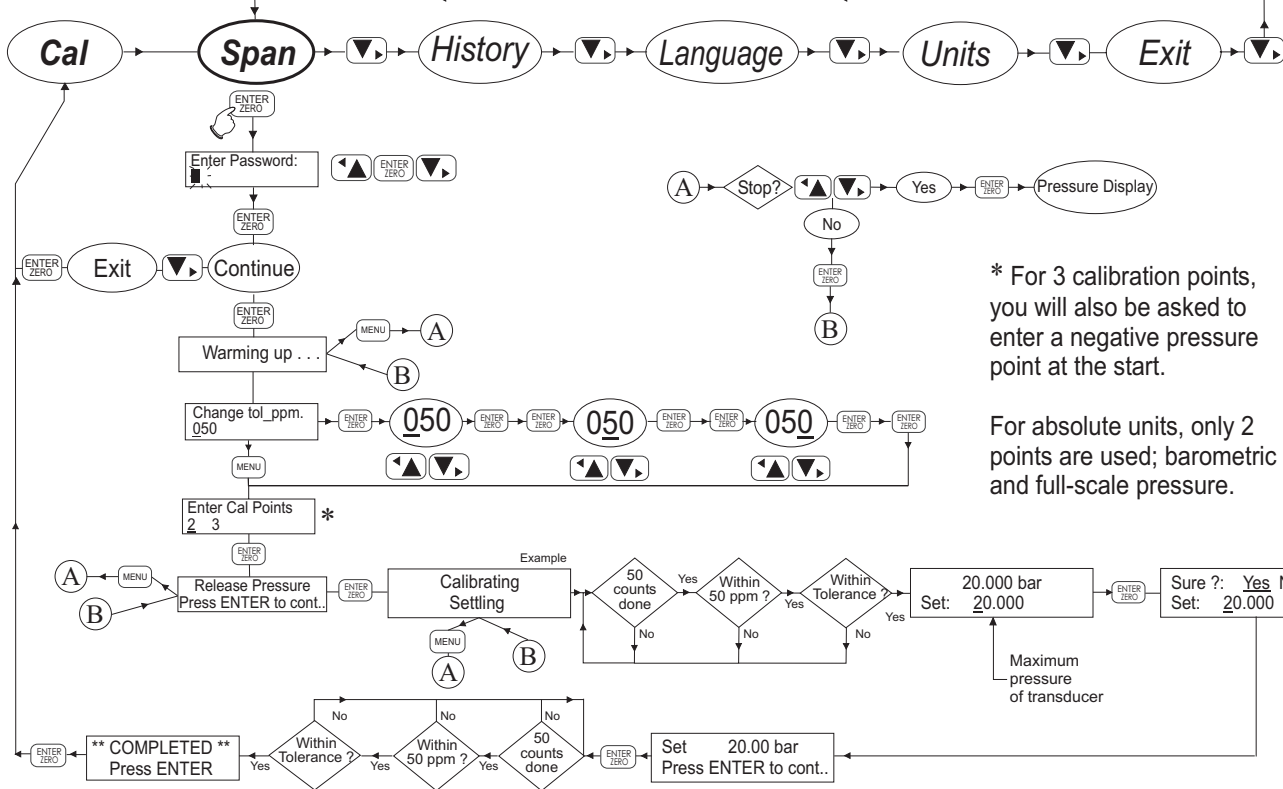

* For 3 calibration points, you will also be asked to enter a negative pressure point at the start.

For absolute units, only 2 points are used; barometric and full-scale pressure.

Menu 3 cal-menu History

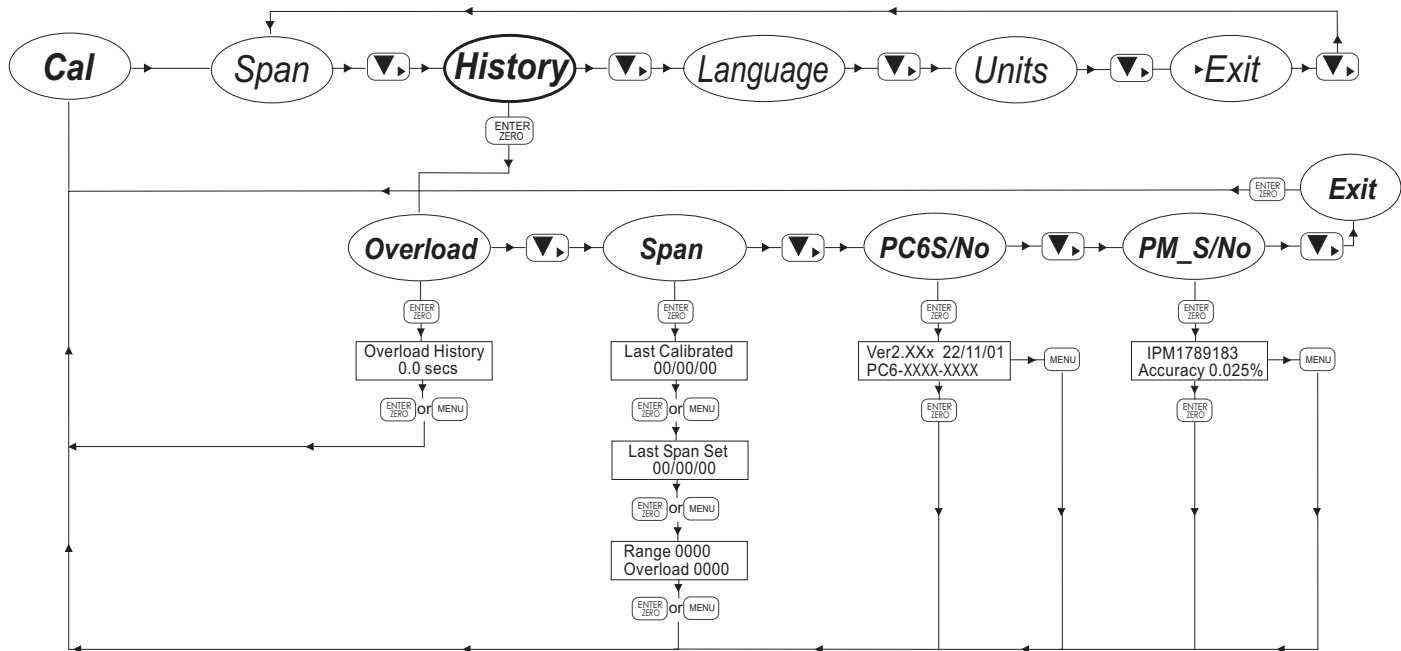

Menu 3 cal-menu Language

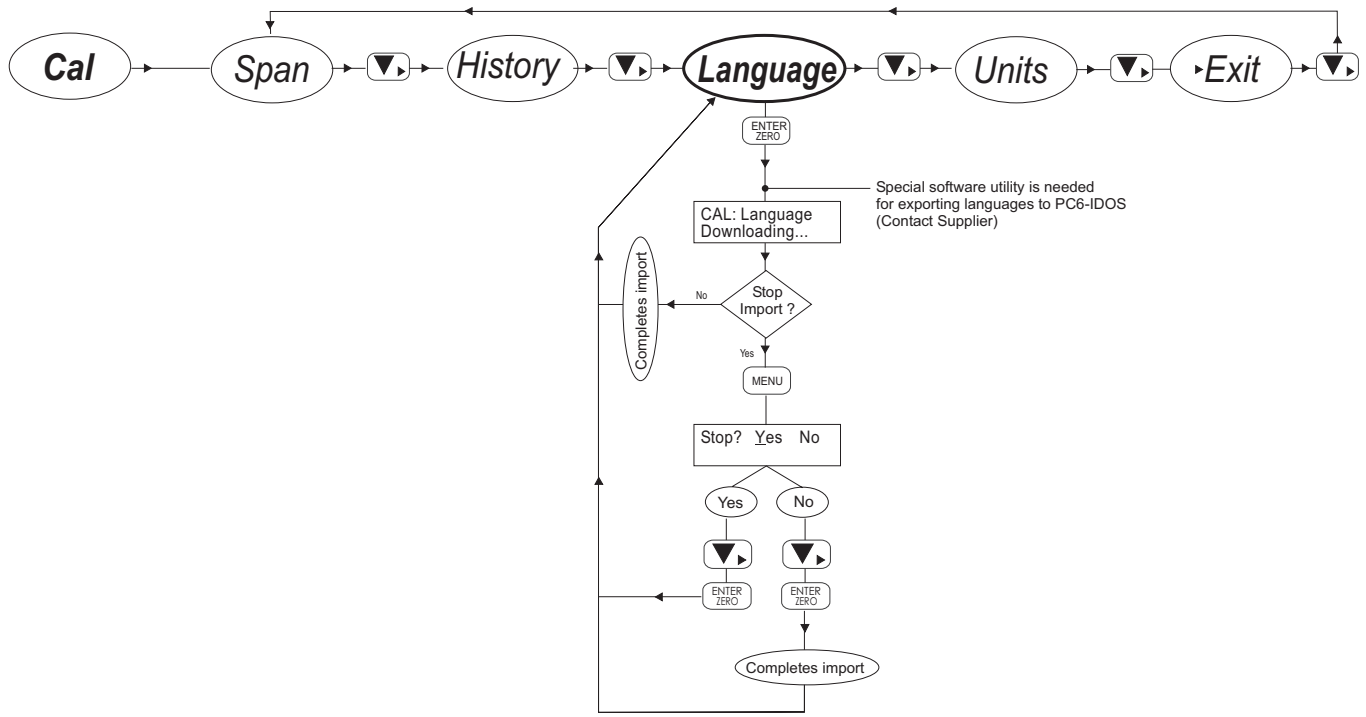

Menu 3 cal-menu Units

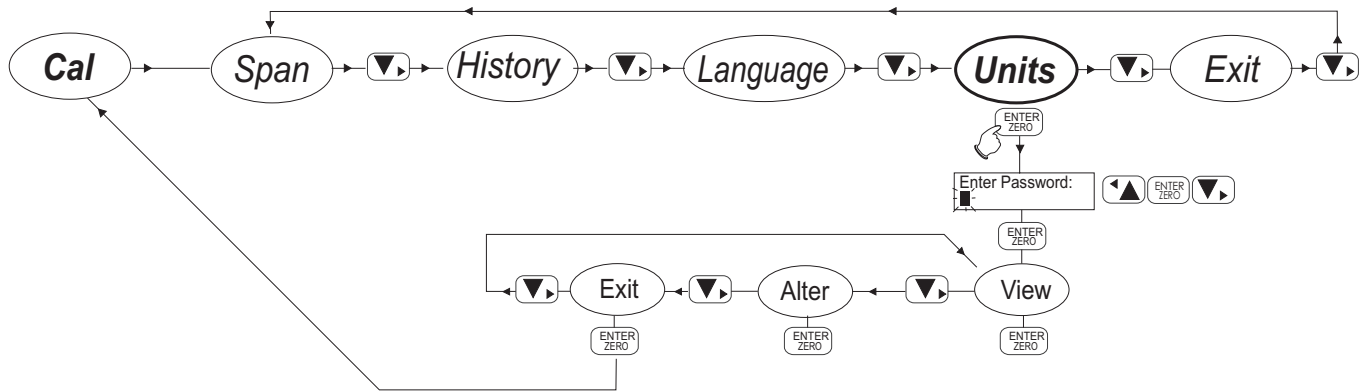

NB There are 2 user-defined units

APPENDIX 1:

External Pressure Module (EPM)

EXTERNAL PRESSURE MODULE (EPM)

The EPM has been developed to work in conjunction with the PC6-IDOS Pressure Calibrator to provide additional pressure ranges without incurring the full cost of extra calibrators. For a full specification and a list of the available pressure ranges, refer to the datasheet. The illustration on Page 57 shows a typical application.

The EPM is an intelligent module that contains a pressure transducer, analogue to digital converter, and the necessary calibration data stored during EPM calibration. For the safe connection and operation of the EPM, refer to the EPM user manual (document K380).

During operation, the EPM sends pressure and temperature related information digitally to the PC6-IDOS, which acts as an intelligent terminal.

The EPM or the PC6-IDOS internal pressure sensor can be selected during calibration using the calibrator menu system.

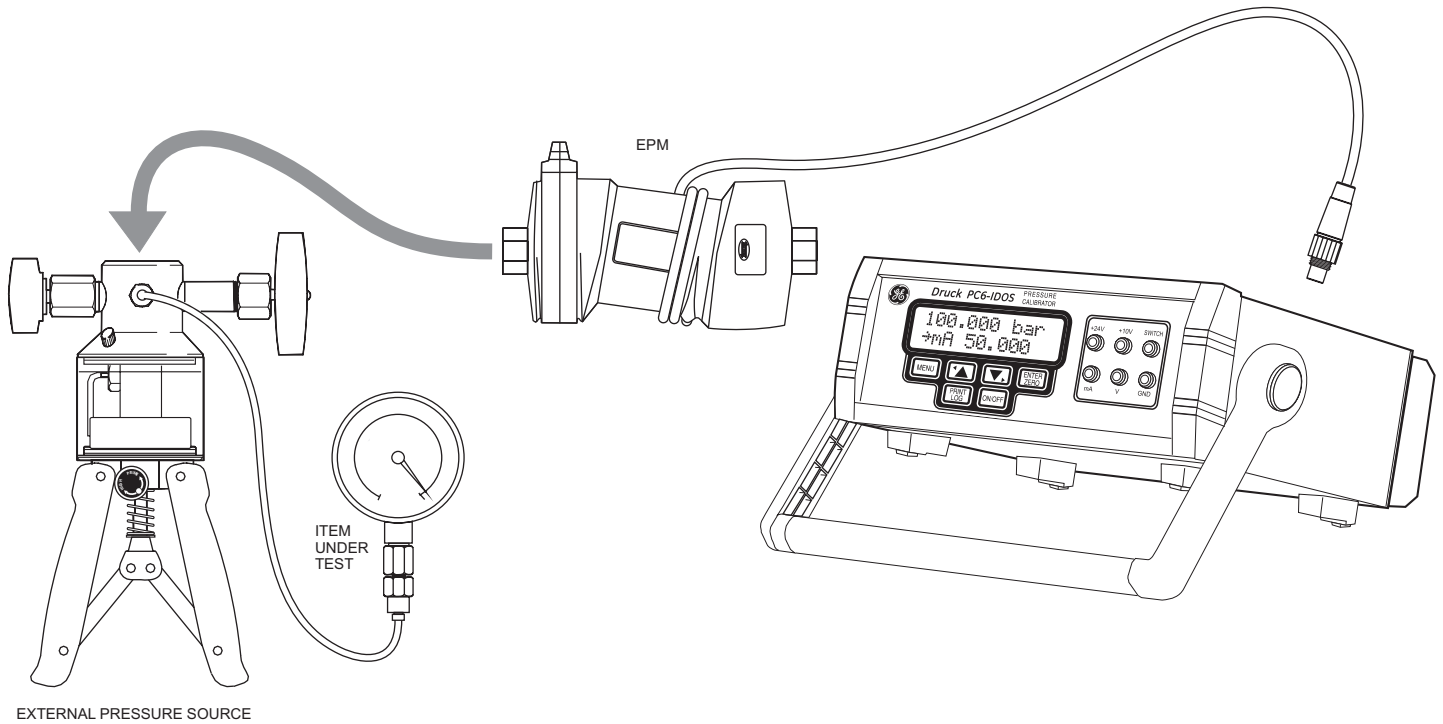

APPENDIX 2:

Calibration Procedures





A.2.0 Calibration Procedures

Calibration Procedures are created with SiCal PRO. Please read this section in conjunction with the SiCal PRO literature.

A.2.1 File Import.



Calibration procedures are downloaded to PC6-IDOS by choosing Import from the File menu (section 1.13.3, page 19).

A.2.1 File Log.



To use a Calibration Procedure, open the file by choosing "Log" from the "Log" menu (section 2.6.1, page 27). Select the desired calibration file by using the   keys and press the  key. Now press the  key twice.

NB if you try to modify the number of records or filename then the file will revert to a normal file ("N" rather than "C" will appear at the end of the filename display).

Once the file is opened you will see the set text followed by the calibration text scrolling on the lower line. To stop the lower line scrolling (and return to normal pressure display mode) press the  key.

Use the  key to log each point. If the current calibration point is outside the accuracy statement that you have set up in the calibration procedure, you will receive a "FAIL" message along with the FS % accuracy figure. If you wish to log this point, press the  key again. Otherwise press the  key and you can adjust the point and log it again.

A.2.2 File View.

Select "View" from the "File" menu (section 1.13.1, page 18) Choose either "data" or "Procedure" with the   keys and press the  key.

- If you choose "data" you will see the following: procedure serial number, description, pressure range, transmitter range (if applicable), accuracy, set text, and the temperature at which the procedure was carried out. Following this header data is the data that you have logged into the file. Note that if you have only just downloaded the calibration procedure from SiCal PRO then the data area will be blank.
- If you choose "Procedure" you will see the same header information as described above followed by the calibration instructions and pressure points for each point.

A.2.2 File Export.

Once you have logged a calibration procedure and you are happy with the data, the file can be uploaded back to SiCal PRO. This file, now complete, can be used for certificates, etc. Please see section 1.13.2, page 19 and the SiCal PRO literature for details.

APPENDIX 3:

Panel Mount Dimensions

PANEL MOUNT DIMENSIONS

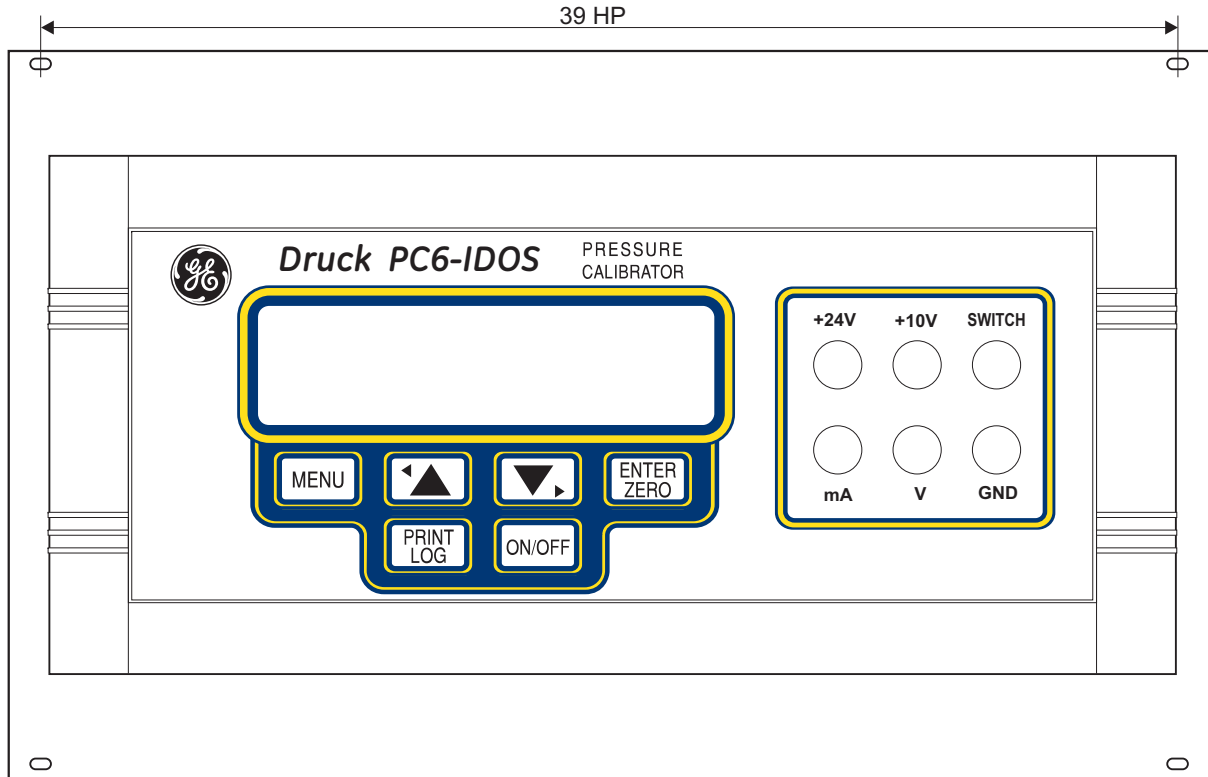

3U x 42HP
See page vi for ordering information.

INDEX

A

absolute v, 34
accuracy..... v
activate a function..... iv
alarm. 21
arrangement..... 4
auto switch off..... 12

B

back-light..... 26
battery..... iii, vi
baud-rate..... v, 29

C

cal menu..... 8, 32
calibration procedure .. 32, 58
charger..... 11
connection panel..... 3, 4
connections..... 3, 10
connection fault 13
convert 23
coupling..... 3, 4
current input..... 10
current overscale 13

D

data entry..... iv
date & time..... 30, 50
display (LCD)..... 3
display light..... 26, 48
display hold..... 12
downloading 19
display symbols 13
dwell-time 24, 47

E

enter..... iv
EPM..... v, 3, 10, 55
event..... 26, 48
export 19, 49

F

file 18, 40
filename 27
flowcharts..... 36
functions..... 5
FS (full scale) v, 22

H

high..... 21, 41
history 35, 52

I

import 19, 49
indicator..... ii
input..... 3

K

keypad..... 2
keys iv

L

language .. 30, 35, 50, 53
LCD..... 3
leak. (test) 17, 38
log..... 27, 49
low..... 21, 41

M

maintenance..... vi
maximum (Max)..... 15
measure 15, 22

memory errors 12
menu selection..... iv
messages & parameters..12
microprocessor..... vi
minimum (Min) 15
mA 15, 22

N

nudge 25

O

overload..... v, 12
overscale..... 13

P

P to V / mA 23
panel mount vi, 60
password 33
PM_S/No 8, 35
Port 7, 31, 50
Power_Off 7, 31, 50
pressure connections .. vi, 10
pressure media vi
pressure range..... v
print..... 12

Q

quick reference..... iv
quick connect coupling.. vi, 3, 10
(Quick-Fit)

R

range 23
ramp 24, 25, 47
rate 24, 47
resolution..... v, 26, 48
root 22, 24
RS232 11, 29, 48

S

safety warning..... iii
serial number 8, 33, 52
set menu..... 20
short detected 13
software..... vi
span 32, 51
specifications..... v, vi
status 24, 29
step 24
stop bits..... 29
storage..... 19
source 15, 23
switch test 11

T

tare..... iv, 15
temperature..... 15
text 22
timed 11, 26

U

unit 15, 35
units 35, 54

V

v, mA 15, 22, 39, 42
voltage input..... 10
voltage output..... 11
voltage overscale..... 13
v-out 26, 48

W

warning..... iii

Z

zero..... 22, 30, 50

Customer service

Druck has joined other GE high-technology sensing businesses under a new name GE Sensing.

Visit our Website: www.gesensing.com

