



## GAST DAA 隔膜式真空泵 压缩机

### 为什么选择我?

微型隔膜式压缩机与真空泵,具有安静,轻巧,无油,长寿命的特性,应用领域广泛,有直流和交流电机可以选择.



### 应用

便携式牙科设备,呼吸机,消毒器,高压灭菌设备,空气采样,水质采样,水质净化系统,曝气池,汽车排放测试,食品加工,制图设备等

### 优点

- 4级电机 2.4CFM,60PSI
- 2级电机 3.8CFM,60PSI
- 4级电机双缸 25.5" HG,2.2CFM
- 2级电机双缸 25.5" HG,3.6CFM
- 4级电机双缸 29.0" HG,1.15CFM
- 2级电机双缸 29.0" HG,2.0CFM
- 无油式
- 结构坚固,维护成本低
- 低噪音,小巧轻便





## 规格型号

型号	电机参数	转速RPM		功率		重量
		60Hz	50Hz	HP	KW	
压缩机						
DAA-P501-EB	100/115,50/60-1,4P	1575	1275	1/4	0.19	12.7Kg
DAA-P501-ED	220/230,50/60-1,4P	1575	1275	1/4	0.19	12.7Kg
DAA-P517-ED(欧标,无堵塞)	220/230,50/60-1,4P	1575	1275	1/4	0.19	12.7Kg
DAA-P513-EG(欧标,含电容,无堵塞)	240,50-1,P4	---	1275	1/4	0.19	12.7Kg
DAA-P501-GB(无电容)	110/115,50/60-1,2P	3000	2500	1/2	0.37	12.7Kg
DAA-P503-GB(独立电容)	110/115,50/60-1,2P	3000	2500	1/2	0.37	12.7Kg
DAA-P501-GD(无电容)	220/230,50/60-1,2P	3000	2500	1/2	0.37	12.7Kg
DAA-P503-GD(独立电容)	220/230,50/60-1,2P	3000	2500	1/2	0.37	12.7Kg
DAA-P512-GD(附电容)	220/230,50/60-1,2P	3000	2500	1/2	0.37	12.7Kg
真空泵						
DAA-V505-EB	110/115,50/60-1,4P	1575	1275	1/4	0.19	10.4Kg
DAA-V502-EB(双缸)	110/115,50/60-1,4P	1575	1275	1/4	0.19	10.4Kg
DAA-V505-ED	220/230,50/60-1,4P	1575	1275	1/4	0.19	10.4Kg
DAA-V502-ED(双缸)	220/230,50/60-1,4P	1575	1275	1/4	0.19	10.4Kg
DAA-V510-EG(欧标,含电容,无堵塞)	240,50-1,4P	---	1275	1/4	0.19	10.4Kg
DAA-V505-GB	110/115,50/60-1,4P	3000	2500	1/2	0.37	12.7Kg
DAA-V507-GB	110/115,50/60-1,4P	3000	2500	1/2	0.37	12.7Kg





产品尺寸( mm,英寸)

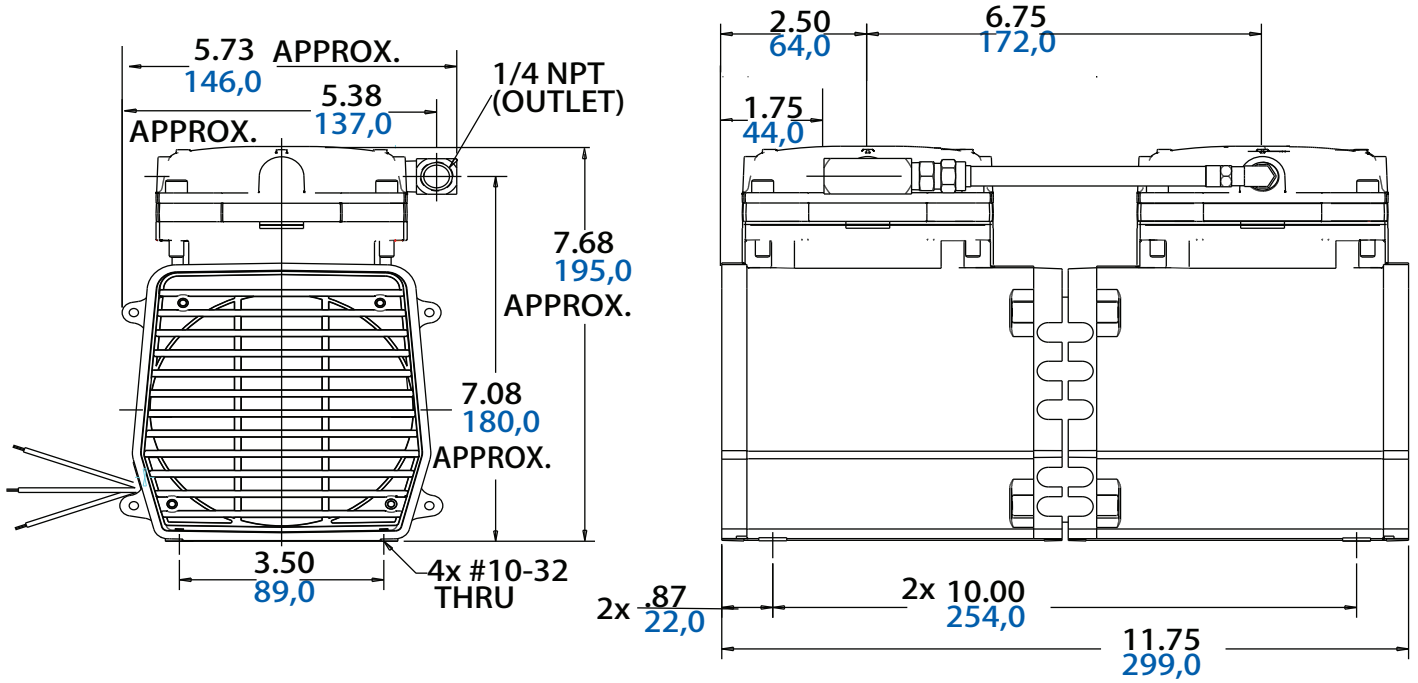



产品性能(公制,英制)

单缸

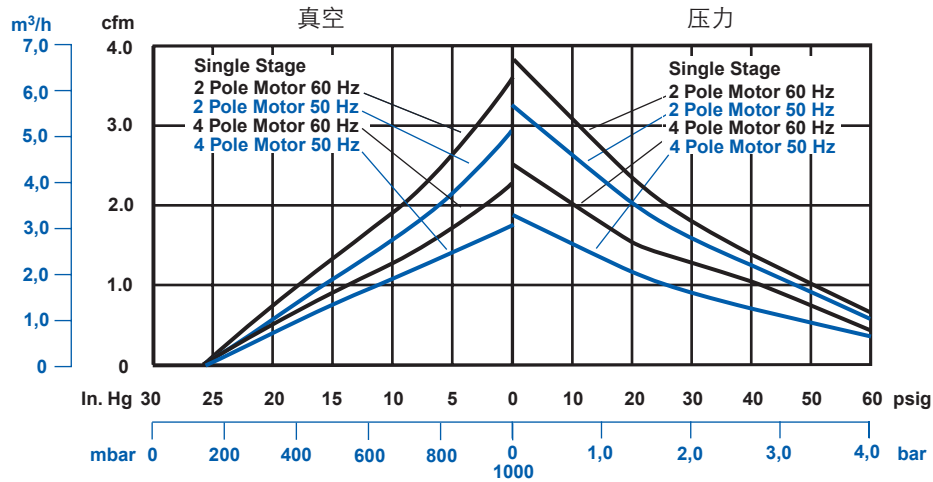

双缸

