

FLAT SURFACE CPVC AND PVDF pH AND ORP SENSORS

This Combination pH/Reference electrode or ORP (REDOX)/Reference Electrode is ruggedly made and easy to use. Because the pH responsive glass flat surface is relatively thin, care should be taken so that the glass does not become scratched or broken. It is also important that ORP measuring surfaces are not scratched or gouged. The suggestions in this sheet are intended to help avoid these problems. The built-in sealed reference design of this electrode eliminates the need to add filling solutions and minimizes reference dryout. This design feature also allows the electrode to be used in pressurized systems (refer to specification sheets or consult the factory for maximum pressure/temperature limit information)

SECTION 1.0 IMPORTANT CONSIDERATIONS

1. The pH Electrode is shipped in a cap containing a solution of pH 4 buffer and potassium chloride. ORP (REDOX) Electrodes are shipped in caps containing a piece of cotton wetted with tap water. The electrode should remain in the cap until it is used. If the electrode is used infrequently the cap and its solution should be saved and the electrode stored in it. Store pH electrodes in pH4 buffer if soaking solution is discarded. Remove cap and label to use (SEE FIG 1)
2. Electrodes are a form of a battery and have limited shelf lives. Electrodes in inventory should be rotated so that the older electrodes are used first. The date code is stamped on each electrode by fiscal week and year (example: 5204 = week 4 of December 2004)(SEE FIG 2)
3. After exposure to a sample, buffer or rinse solution, carryover can be minimized by blotting-never by wiping-the electrode with a clean, non-abrasive paper or a clean cloth towel. **DO NOT USE A BRUSH ON pH GLASS.** (SEE FIG 3)
4. As a rinse solution, use a part of the next sample or buffer, which is to be measured. This action also will minimize contamination from carryover.
5. When calibrating, use a buffer close in value to that expected from the sample for 1 point calibrations or as the first buffer for 2- point calibrations (see below). This action will minimize span errors.
6. Readings stabilize faster in some solutions than others; allow time for the reading to stabilize. In general, with new electrodes stable readings in buffer are obtained in 10-15 seconds. (FIG. 4)

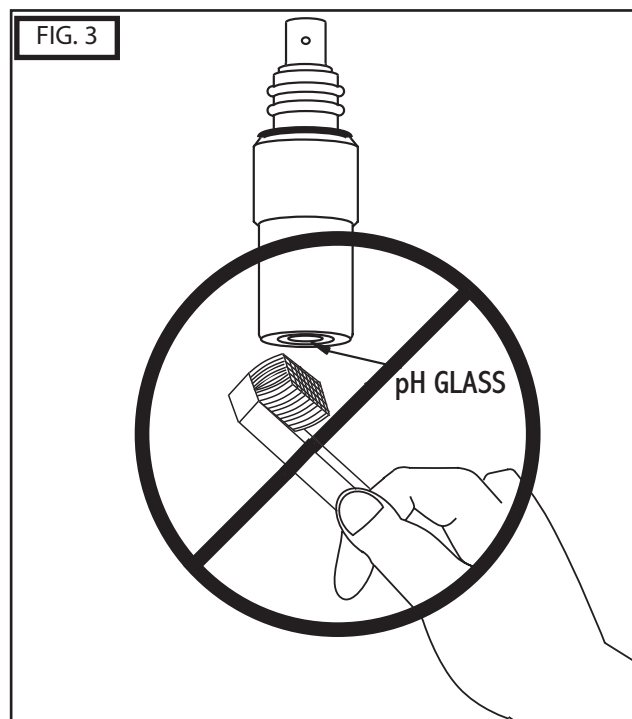
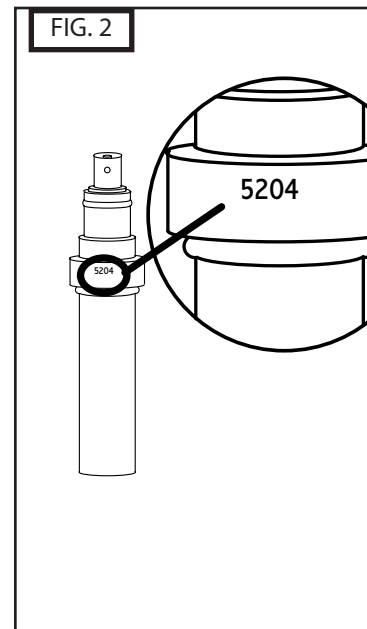
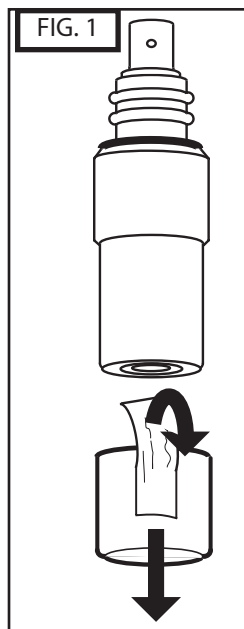

SECTION 1.0 HELPFUL OPERATING TIPS (CONT)

7. All pH electrodes age with time. Aging is characterized by shortened span and slower speed of response. Aging is best detected by the 2 point Calibration method. If the pH meter has manual or microprocessor slope (span) controls, the controls can be adjusted to compensate for electrode span errors (but will not affect the speed of response).

8. Electrodes should be replaced when their readings cannot be corrected by the meter's controls (see FIG 5) and/or when their speed of response is too slow for the application for which they are being used. The frequency of electrode replacement is a function of the application; electrodes operating in hot liquids at very high or very low pH values will have shorter lives than those operating at neutral pH and ambient temperature.

9. Coatings on an electrode's surface prevent new liquids from contacting an electrode's measuring surface and can mimic the effects of electrode aging. Before concluding that an electrode needs replacing check its surface for coatings as shown in FIG 6.

10. Temperature affects electrode readings in two ways. First, the output of an electrode varies with temperature. For pH electrodes this effect can be corrected by manual or automatic temperature compensation (ORP/Redox readings are not corrected for temperature effects). Secondly, the real pH or ORP value, independent of the electrode measuring the value or use of the temperature compensation, is temperature dependent. This fact means, for example, that the readings at 25C and 75C will be (and, in fact are) different.

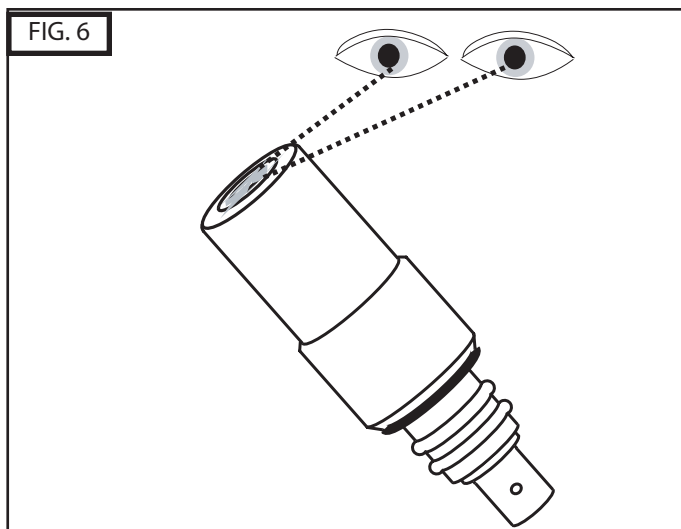
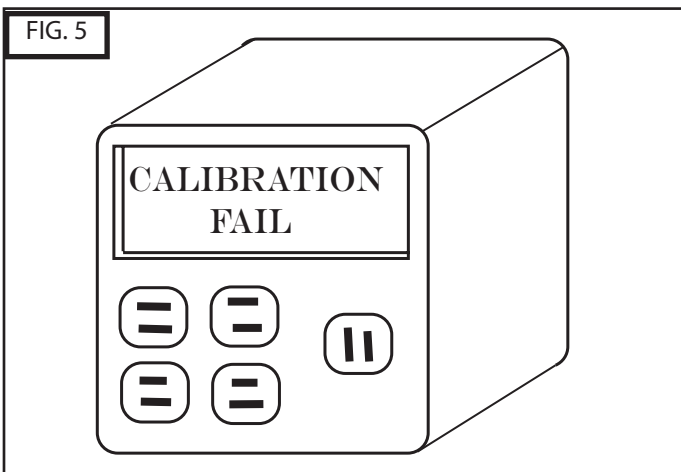
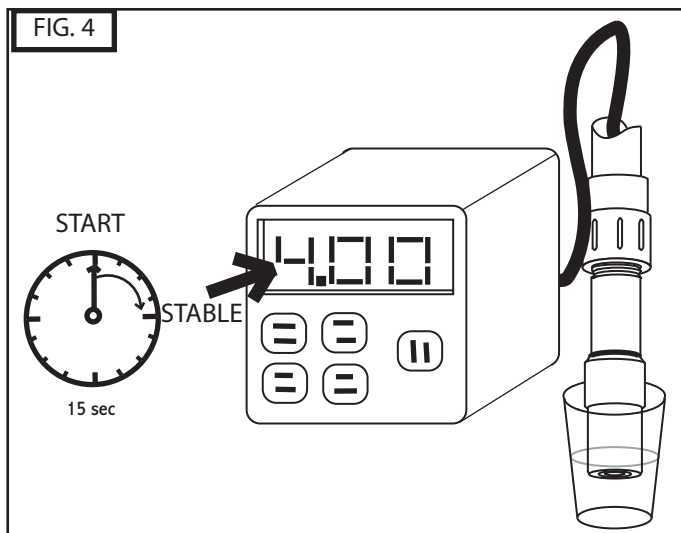

SECTION 2.0 CALIBRATION PROCEDURE

As a rule, follow the procedures shown in the pH Meter's Instruction Manual. These procedures will vary depending on whether the meter is a simple type with manual adjustments, a micro-processor type or a pH transmitter.

The frequency of calibration is a function of many factors. These factors include:

1. The accuracy required by the application.
2. The value of the off-specification product versus the cost of calibration.
3. The coating or abrasive nature of the application.
4. The stability of the pH Electrode and pH Meter as a system.

SECTION 2.0 CALIBRATION (CONT.)

The frequency of calibration is really determined by experience. At a new installation calibration might initially be checked every few hours or shift with the calibration changes noted in a log. As a pattern of longer stability is found, the time between calibration checks can be increased to once a day or once a week. Although the frequency of calibration is solely the responsibility of the user, once a week is the longest recommended interval between calibrations (see FIG 7).

System Calibration Concepts

The pH Electrode and the pH Meter should always be calibrated as a system. Electronic calibration of a pH Meter with a pH signal simulator checks the meter only and does not correct for imperfections of the pH electrode. Even if perfect when new, the performance of pH electrodes varies with time, usually in an unpredictable way. When changing electrodes or connecting an electrode to a different pH meter re-calibration must be performed.

2-Point Calibrations

Two point calibrations correct for both the pH electrode's offset and span errors. Since both the offset and span vary with time the 2 point method is the preferred one. Choose buffer pH7 for zero point and a second buffer close to operating range.

Grab Sample Calibrations

The Grab Sample Calibration method is used when it is difficult or undesirable to remove an electrode from a system. This method involves obtaining a sample of the liquid being measured and noting the meter's reading at that time. The sample's reading is obtained by use of a calibrated lab or portable meter and that reading is compared to that of the on-line meter. The on-line meter is adjusted by the difference between the readings. It is important to use the difference between the readings because the system's reading may have changed in the intervening time. It is important that the sample being measured by the lab meter be at the process temperature or erroneous results may occur (see section 11 on the previous page).

Calibration Procedures

Stepwise calibration procedures are noted in the pH Meter's Instruction Manual. The following suggestions will help make calibrations as accurate as is possible.

1. Before placing the electrode in a new buffer, use an absorbent paper towel or clean absorbent cloth to blot, not wipe, off any liquid that clings to the electrode. This action will minimize carry-over that could contaminate the buffer.

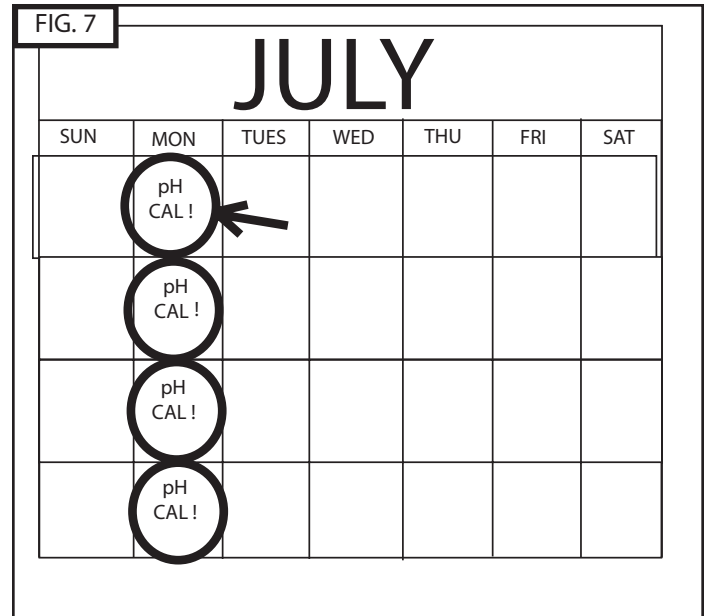
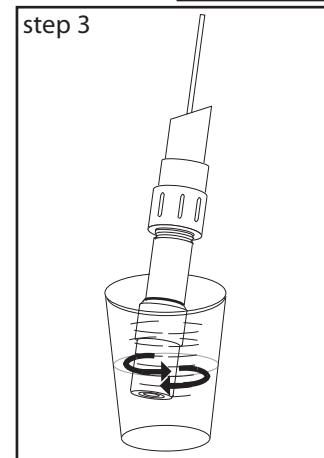
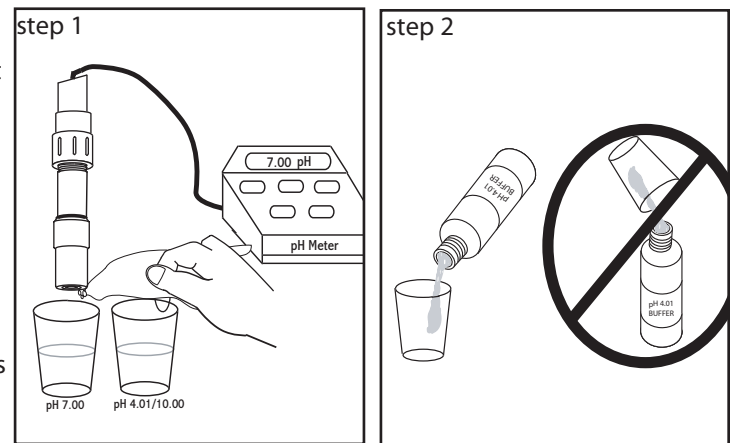

FIG. 8





2. Always use fresh buffers. Safely dispose of the buffers after they have been used for calibration. Do not return them to their bottles; this action could contaminate the buffers.
3. Stir the electrode in the buffer to make certain that the fresh buffer quickly reaches the electrode's measuring surface.

Intermittent Operation

Some facilities are only operated part of the time. When out of operation, electrodes must not be allowed to be exposed to air and become dry. Electrodes should be removed from such systems and stored in their bottles or caps or in a beaker filled, preferably, with pH 4.0 Buffer. In some instances, power to the meter is shut off; this condition can be harmful to electrodes. Electrodes should be disconnected from un-powered meters.

SECTION 4.0 ELECTRODE CLEANING

Coating of an electrode's measuring surface can lead to erroneous readings including shortened span and slow response times. The type of coating determines the type of cleaning technique. Soft Coatings can be removed by vigorous stirring, by use of a squirt bottle or, very carefully, by gently wiping with a soft, clean non-abrasive paper or cloth. **DO NOT USE ANY BRUSH OR ABRASIVE CLEANER ON pH GLASS!** (Fig 10)

Hard Coatings should be chemically removed. The chemical used to remove the coating should be the least harsh chemical that dissolves the coating in 1 or 2 minutes and does not attack the electrode's materials of construction. For example, a calcium carbonate coating might be removed with 5% HCl (muriatic acid). Oily or Organic Coatings are best removed with detergents or an appropriate solvent that does not attack the electrode's materials of construction. For example, isopropyl alcohol might be used but acetone should be avoided if the electrode's body is made of CPVC.

NOTE: WHEN USING CHEMICALS OR SOLVENTS CARE SHOULD BE TAKEN AND APPROPRIATE EYE, FACE, HAND, BODY AND/OR RESPIRATORY PROTECTION SHOULD BE USED.

Abrading or sanding a pH electrode's surface should never be done. However, the measuring surface of an ORP/REDOX electrode may be gently abraded by use of 600 grade wet silicon carbide paper, jeweler's rouge or very fine steel wool, but try to clean chemically before abrading with 600 paper.

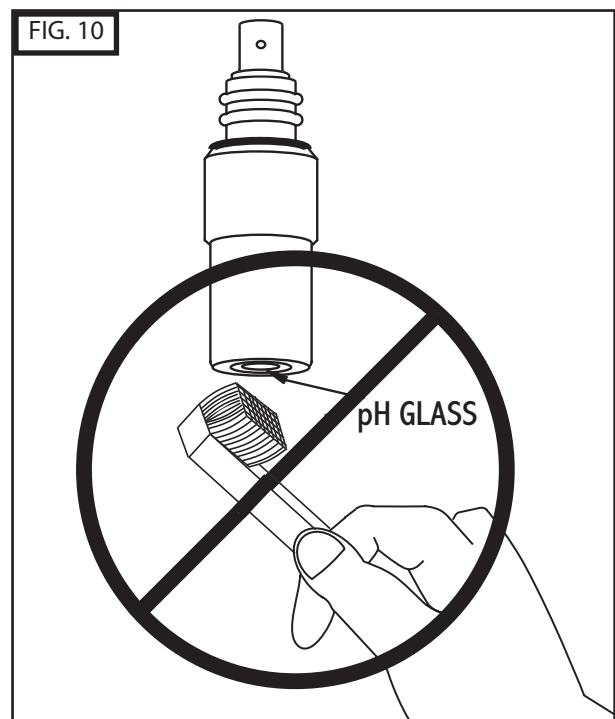
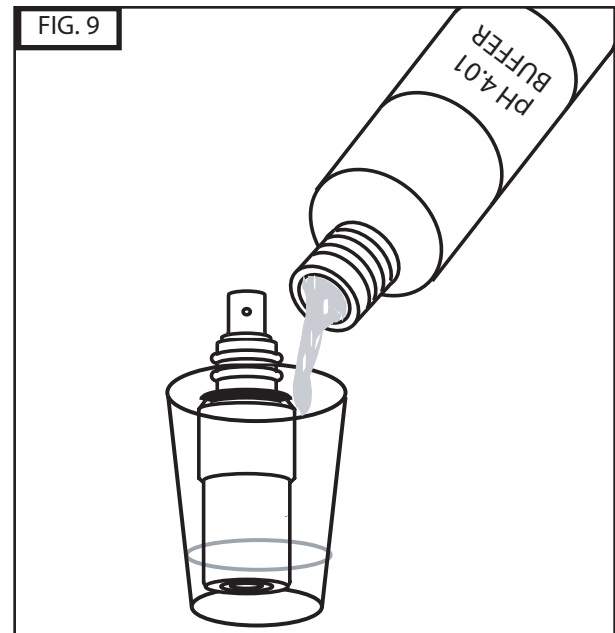

11751 Markon Dr.
Garden Grove, CA 92841 USA

Tel: 714-895-4344
Fax: 714-894-4839
E-mail: info@sensorex.com
www.sensorex.com

Parts covered by this product instruction sheet include:
S645CD, S645CD-ORP, S650CD, S650CD-ORP, S655CD, S655CD-ORP, S660CD, S660CD-ORP,
S661CD, S661CD-ORP, S662CD, S662CD-ORP