

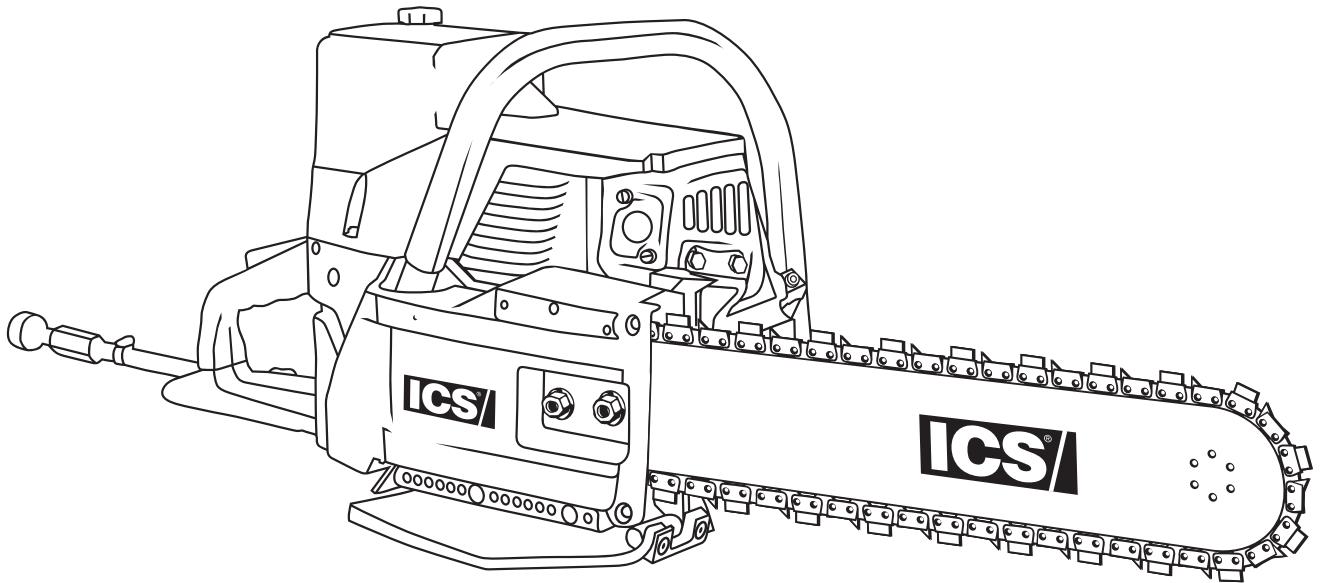

633GC



OPERATOR'S MANUAL

SYMBOLS & LABELS	4
SAFETY	5
TECHNICAL SPECIFICATIONS	8
SET-UP	9
OPERATION	12
MAINTENANCE	17
TROUBLESHOOTING	25
REFERENCE	26

THE FOLLOWING SYMBOLS & DEFINITIONS ARE FOUND THROUGHOUT THIS MANUAL AND ARE DESIGNED TO MAKE YOU AWARE OF POTENTIAL HAZARDS OR UNSAFE PRACTICES.



A potentially hazardous situation exists which, if not avoided, could result in death or serious injury.



A potentially hazardous situation exists which, if not avoided, may result in minor or moderate injury or property damage.



A potential situation exists which, if not avoided, may result in product or property damage.

THE FOLLOWING SYMBOLS & LABELS MAY BE FOUND IN THIS MANUAL OR ON THE SAW



Read the operator's manual carefully and understand the contents before you use this equipment.



Always use:

- Protective helmet
- Ear protection
- Protective glasses or full face protection



Wear hand protection

⚠ WARNING

- Do NOT insert tool into slot narrower than chain
- Do NOT operate tool without solid footing and firm hand grip
- Use only in well ventilated area
- Failure to observe these precautions can result in serious injury

THE FOLLOWING SYMBOL APPLIES TO ALL THE ITEMS LISTED ON THIS PAGE



A potentially hazardous situation exists which, if not avoided, could result in death or serious injury.

Chain breakage can result in high-speed ejection of parts, which can result in death or serious personal injury to operators or bystanders. The items listed below are critical to minimizing the risk of chain breakage and injury.

- **DO NOT** operate a diamond chainsaw with a damaged, modified, broken, or missing side cover, bottom guard, or guard flap. The side cover, bottom guard, and guard flap provides protection against contact with moving parts, ejected debris, broken diamond chain, thrown water and concrete slurry.
- **DO NOT** operate a saw with loose, missing, damaged or improperly repaired parts.
- **DO NOT** install or run the chain backwards. The bumper must lead the segment into the cut.

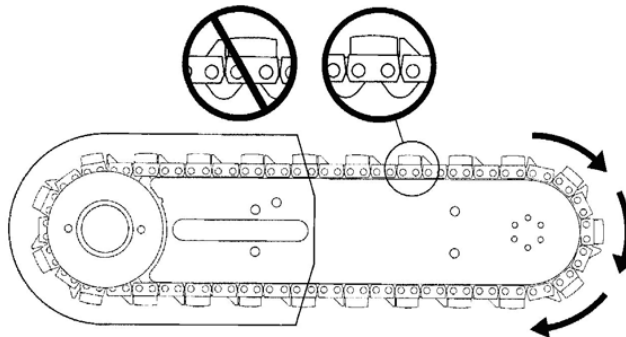

- **DO NOT** insert a diamond chainsaw into a slot narrower than the chain segments. Rapid pushback might occur. Reference: Most diamond segments are .225 inches (5.72 mm) wide.
- **DO NOT** use damaged, modified or improperly repaired chain.
- **DO NOT** run a diamond chainsaw upside-down. Concrete debris can fly back into the operator's face.
- **DO NOT** cut ductile iron pipe with a diamond chainsaw. Segment loss or chain breakage may occur.

THE FOLLOWING SYMBOL APPLIES TO ALL ITEMS LISTED ON THIS PAGE

 **CAUTION**

A potentially hazardous situation exists which, if not avoided, may result in minor or moderate injury or property damage.

- Always turn a diamond chainsaw OFF when performing maintenance on the saw including chain tensioning.
- Never use equipment that is not functioning properly. Have the saw repaired by qualified service personnel.
- Turn engine OFF before refueling. Keep away from open flame. Always provide adequate ventilation when handling fuel. Move diamond chainsaw at least 10 feet (3 m) away from refueling area before starting.
- SealPro® diamond chains require a minimum water pressure of 20 psi (1.4 bar). Insufficient water supply may result in excessive wear to the chain, which can lead to loss of strength and chain breakage.
- Never start a diamond chainsaw unless the bar, chain and side cover are properly installed.

**GENERAL SAFETY PRECAUTIONS**

- Always wear protective clothing, including hard hat, eye protection, hearing protection, and gloves.
- Avoid loose fitting clothing.
- Perform safety checks before starting each day.
- Always operate tool with solid footing and with both hands on saw.
- Remove or control slurry to prevent slippery conditions while cutting.
- Be sure there are no obstructions (plumbing, electrical conduit, air ducts) and no unnecessary people present.
- Set up a well-marked safety zone with a roped boundary and clear signs.
- Provide adequate ventilation when working in an enclosed area. Breathing exhaust gases is dangerous.
- To avoid electrocution, check for live electrical wiring near cutting area.

THE FOLLOWING SYMBOL APPLIES TO ALL ITEMS LISTED ON THIS PAGE

IMPORTANT

A potential situation exists which, if not avoided, may result in product or property damage.

Note: The diamond chainsaw is equipped with a two-stroke engine and must always be run using a mixture of gasoline and ICS[®] two-stroke engine oil. It is important to accurately measure the amount of oil to be mixed to ensure that correct mixture is obtained. When mixing small amounts of fuel, even small inaccuracies can drastically affect the ratio of the mixture.

- This engine is designed to be operated on premium unleaded gasoline.
- Use high quality, unleaded gasoline with a minimum octane rating of 90. If lower octane gasoline is used, engine temperature will increase which will result in a piston seizure and damage to the engine.
- Fuel mixture: 25:1 gasoline/oil mixture. Incorrect fuel mixture is the number one cause of piston seizure.
- Use ICS[®] brand two-stroke engine oil, or other high quality 2-stroke oil that has been formulated for air cooled power equipment.
- Never use two-stroke oil formulated for water-cooled two-cycle engines, such as outboard motor oil.
- Never use motor oil intended for four-stroke engines.

ENGINE BREAK-IN

- It is very important to break-in a new engine to “seat” all moving parts, especially the piston rings.
- To break-in the engine, run one full tank of 25:1 fuel at idle, cycling the throttle every 5 to 10 minutes to prevent loading.
- Failure to break-in an engine may result in piston seizure.

Engine Type	2-stroke, Air Cooled
Displacement	101cc (6.2 cu in)
Horsepower	6.5 HP (4.8 kw) @ 8700 RPM
Engine Speed	11,500+/-500 RPM, Mechanically governed
Diamond Chain Speed	4,950 fpm (25m/s), free running
Idling Speed	2800-3200 RPM
Weight	27.5 lbs (12.5kg) with guide bar and diamond chain
Cut Depth	14 in (36cm) & 16.2 in (41cm)
Bar Lengths	14 in (36cm) & 16.2 in (41cm)
Carburetor	Walbro WGAk3, Throttle shaft sealed,
Ignition	Selettra electronic – Water resistant
Clutch	Centrifugal, three shoe, single spring
Fuel ratio	25:1 gasoline-to-oil
Fuel Capacity	34 oz (1 Liter) 15-18 minutes run time per tank
Water Supply	Minimum 20psi (1.5 bar)
Water Flow	Minimum: 2 gpm (8 lpm)
Noise Level	102dB at 3 ft (1m)
Vibration Level	8 meters/sec ² (front handle)
Engine Break-in Period	One tank, without cutting, cycling throttle
Spark Plug	Champion CJ7Y or Bosch BWS7F

GUIDE BAR AND DIAMOND CHAIN INSTALLATION

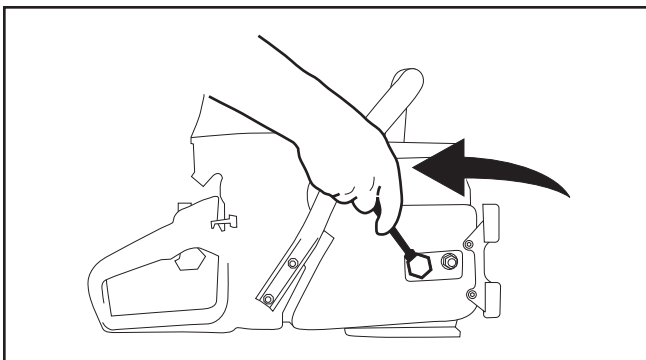

STEP 1
Loosen side cover nuts and remove side cover.

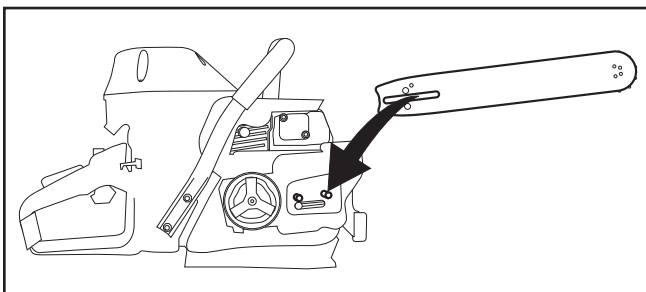

STEP 2
Place bar onto studs and chain adjustment pin.

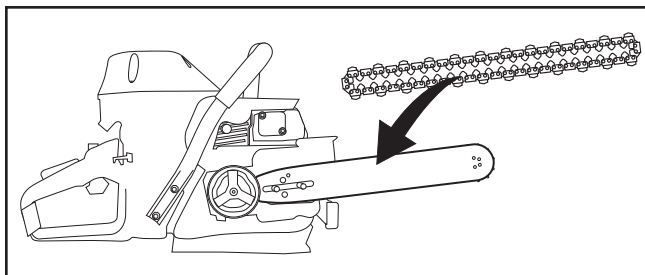

STEP 3
Mount the diamond chain on the guide bar starting at the drive sprocket and continue over the guide bar nose.

Install the diamond chain correctly.
If using a single bumper chain, the bumper must always lead the segment into the cut as shown here.

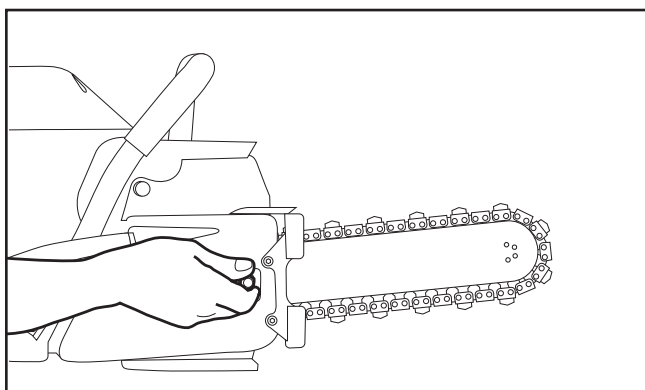
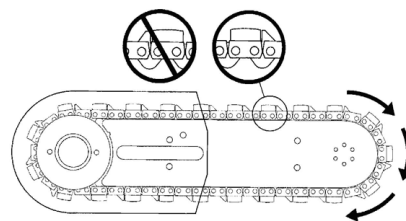

STEP 4
Install the side cover.

GUIDE BAR AND DIAMOND CHAIN INSTALLATION

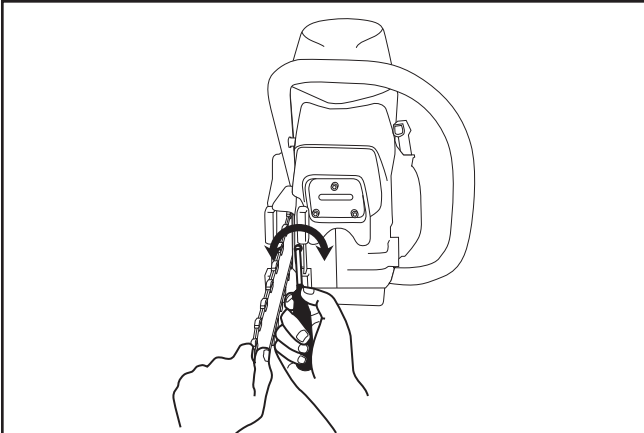
**STEP 5**

Make sure all the drive links are inside the guide bar groove then lift the bar nose and tension the chain by turning the screw clockwise.

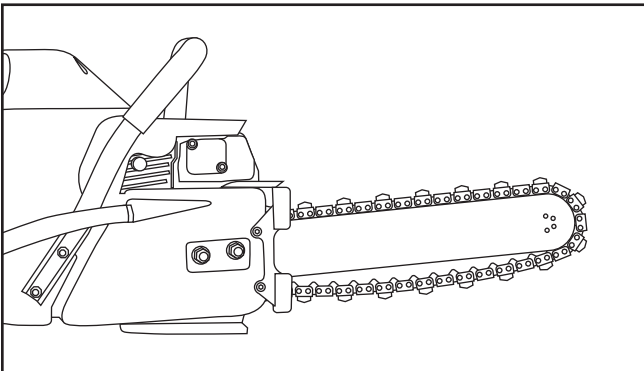
**STEP 6**

If the chain is too loose, it could come off the bar, or it will allow the drive sprocket to spin without turning the chain, which can chew up the chain drive links. If the chain is too tight, a lot of the saw's power goes into turning the chain rather than into the cut. In extreme over-tightened cases, the saw may not be able to turn the chain at all. In addition, damage can occur to the bar nose and premature stretch may occur. See Note 1.

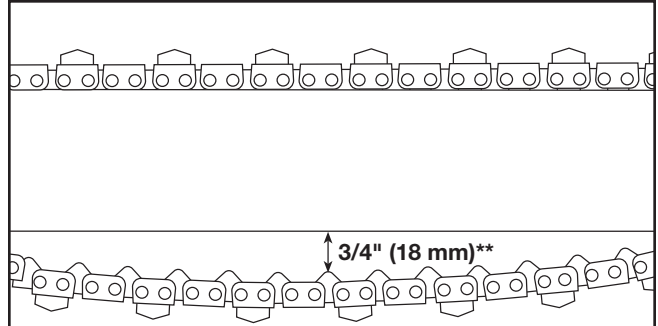

**** As measured without pulling downward (eg. hanging by gravity)**

STEP 7

All chains have a tendency to stretch when used. Diamond chains stretch more than wood cutting chains because of the abrasive materials they are cutting. When a chain stretches to a point where the drive links are hanging approximately 1/2" (12 mm) to 3/4" (18 mm)** below the bar, it's time to tension the chain. See Note 2.

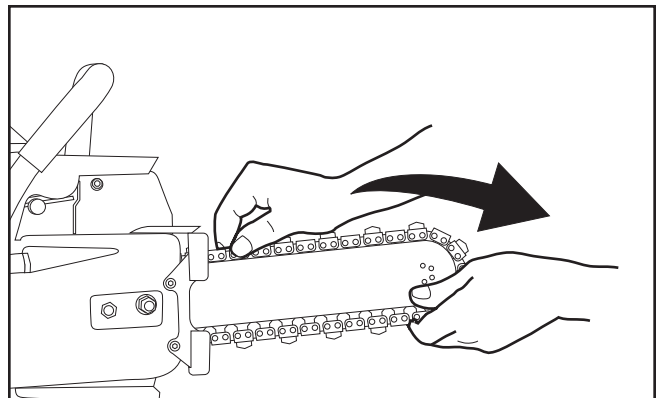
**STEP 8**

Before cutting, check for proper tension by pulling the chain around the bar by hand. If you cannot easily pull by hand, the chain is too tight and needs to be loosened a little. See Note 3.

GUIDE BAR AND DIAMOND CHAIN INSTALLATION

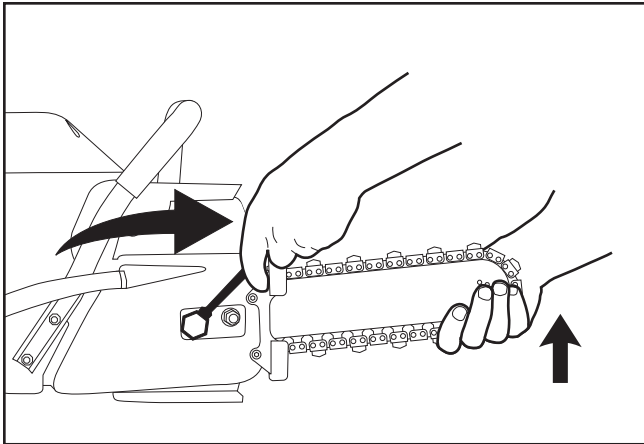
**STEP 9**

Continue to lift up on the nose of the guide bar and firmly tighten the side cover nuts.
NOTE: To prevent chain tensioner breakage, be sure the side cover nuts are tightened to approximately 20 ft-lbs (27 Nm).

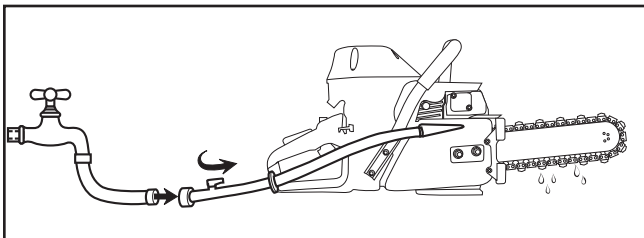
**STEP 10**

Attach to water source with pressure of not less than 20 psi (1.4 bar).

Note 1: Be aware that the guide bar rails may develop sharp edges over time so always pull the diamond chain by the diamond segments.

Note 2: Do not “over tension” the diamond chain. Loss of power will result. It is normal for the driveline to hang underneath the guide bar. The diamond chain should be tight but be able to be pulled around the guide bar by hand.

Note 3: To prevent chain tensioner breakage, be sure the side cover nuts are tightened to approximately 20 ft-lbs (27Nm).

FUEL HANDLING

⚠ CAUTION**FUEL MIXTURE: 25:1 gasoline/oil mixture.**

GASOLINE	OIL
US Gallon	US Fl oz
1	5.2
2 1/2	12.8
5	25.6

GASOLINE	OIL
Liters	ml
1	40
5	200
10	400
20	800

- Use premium unleaded gasoline with a minimum octane rating of 90. If lower octane gasoline is used, engine temperature will increase which can result in a piston seizure and damage to the engine.
- Always provide adequate ventilation when handling fuel.
- Use caution when handling gasoline. Avoid direct contact with skin or inhaling fuel vapor.

FUEL MIXING

- Always mix gasoline and oil in a clean container intended for use with fuel.
- Keep fuel container closed tightly to prevent moisture from getting into the fuel.
- Always begin mixing fuel by adding half the amount of gasoline to be used. Then add the correct amount of two-stroke oil for 25:1 mixture and finish filling the container with gasoline.
- Do not mix more than one month's supply of fuel. This helps prevent the separation of the two-stroke oil from the gasoline (varnishing).
- If the saw is not used for an extended period of time (3 months) the fuel tank should be emptied and cleaned.

FUELING

- Always shut off the saw before fueling.
- Before fueling, clean the area around fuel cap to prevent dirt from contaminating the fuel. Contamination of the fuel tank can lead to saw malfunction.
- Thoroughly mix the fuel in it's container before fueling.
- Slowly open the fuel cap to release any pressure that may have built-up in the tank.
- After adding fuel, tighten the fuel cap carefully and secure with a wrench.

STARTING AND STOPPING A DIAMOND CHAINSAW**⚠ WARNING**

Never start a diamond saw without the bar, chain and side cover properly assembled. Otherwise, the clutch can come loose and cause personal injuries.

⚠ CAUTION

Always move a diamond chainsaw at least 10 feet (3 m) away from the fueling area before starting.

IMPORTANT

Place the diamond saw on clear ground. Ensure that secure footing is established and chain is not contacting any objects.

COLD ENGINE STARTING PROCEDURE

1. Toggle the ignition switch to the "START" position and pull the choke lever out.
2. Lock the throttle in the start position by depressing the trigger (A) and trigger interlock (B) at the same time.
3. Depress and hold throttle lock button (C) while releasing the trigger and trigger interlock in succession.
4. Open the water valve 1/4 turn.
5. Place the diamond chainsaw on the ground making sure the chain is free of any obstructions.
6. Place right foot on the base of the rear handle.
7. Place left hand on front handle.
8. With right hand, slowly pull starter handle until the starter pawls engage.
9. Pull the starter cord (*hard, fast, short pulls*) until engine fires or "pops" - should be 1 to 7 pulls.
10. Push the choke lever in.
11. Pull the starter cord until engine starts - should be 1 to 2 pulls.
12. When the engine starts, allow the engine to idle. Pull on the throttle trigger several times to help warm up the engine.
13. Open the water valve completely.

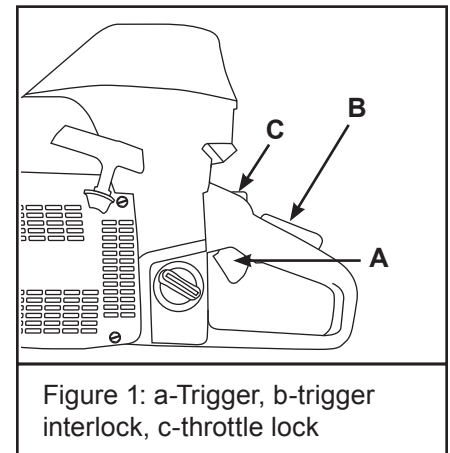

Figure 1: a-Trigger, b-trigger interlock, c-throttle lock

WARM ENGINE STARTING PROCEDURE

1. Use the same procedure as starting cold engine, but **DO NOT pull choke lever out**. If choke is used, the carburetor will flood with gas.
2. If the engine does not start in 3 hard, fast pulls with the throttle locked, unlock the throttle and pull the starter cord 3 more times.
Note: To hold the trigger fully open it may be necessary to insert right foot into rear handle opening and twist.

STOPPING THE SAW

- To turn the engine off, toggle ignition switch to the "STOP" position. Close water valve.

PRE-CUT CHECKLIST

- Proper Chain Installation: The bumper should lead the segment into the cut, double bumper chains may be mounted in either direction.
- Proper Chain Tension: The chain should be tight but easily pulled around the guide bar by hand.
- Ensure all safety devices are properly mounted and functional and that all controls are in proper working order.
- Be sure there are no obstructions (plumbing, electrical conduit, air ducts) and no unnecessary people present.
- Always wear protective clothing, including hard hat, eye protection, hearing protection, non-slip safety boots, and gloves. Avoid wearing loose fitting clothing.
- Adequate Water Supply and Pressure:
Minimum Flow: 2 gpm (8 lpm)
Minimum Water Pressure: 20 psi (1.4 bar)
- Diamond chains with SealPro® require a minimum water pressure of 20 psi (1.4 bar).



IMPORTANT

The single most important factor an operator can control to increase chain life is to use adequate water pressure. Insufficient water supply will result in excessive wear to the chain, which can lead to loss of strength and chain breakage.

PLANNING THE CUT

- Select the proper chain type for the material being cut.
- Outline the cut with a permanent marker for a visual cutting guide.
- Avoid pinching the guide bar and chain. Always cut the bottom of an opening first, then top, and then the sides. Save the easiest cut for last.
- For the straightest cuts use the “Step Cut” method. First score the entire cut line approximately a half-inch deep using the nose of the bar. Next, deepen the cut by about two inches. Then plunge all the way through and complete the cut using the Wallwalker®.
- Be sure cut concrete cannot fall and injure operator or bystanders. Concrete is very heavy, one cubic foot = 12”x12”x12” = 150 lbs. (30cm x 30cm x 30cm = 68kg).
- Check for live electrical wiring near the cutting area or in the concrete to avoid electrocution.

CUTTING WITH THE 633GC

To start a cut, hold trigger on full throttle and slowly plunge the nose of the bar straight into the wall. Lengthen the cut and engage the point of the fixed Wallwalker®. Use the fixed Wallwalker® as a pivot point and pull up on the rear handle to rotate the bar into the cut.

CUTTING TIPS

- Always operate the diamond chainsaw at full throttle. Apply enough feed force so that the free running RPM drops 20 to 30%. If too much force is applied, the saw will lug or stall. The chain will not have enough speed to cut effectively. If too little feed force is applied, the diamonds will skid and glaze over.
- For straighter cuts use the “step cut” method. First score the entire cut line with the nose of the guide bar approximately 1/2 inch (12mm) to 1 inch (25mm) deep. Next, deepen the cut by about 2 inches (50 mm). This groove will help guide the guide bar for a straight cut. Then plunge all the way through and complete the cut using the fixed Wallwalker®.
- Plunge cut instead of starting at the top of the wall. This will reduce chatter, extend diamond life, create a straighter cut and more quickly enable the use of the Wallwalker®.
- Use the fixed Wallwalker® to help cut more efficiently and reduce operator fatigue. The fixed Wallwalker® is a fulcrum that can be used to apply additional force when cutting. To use correctly, plunge into the wall and simply engage the point of the fixed Wallwalker® into the cut and pry upward with the rear handle.
- As the saw begins to rotate up, feed force is developed down the line of the intended cut. Once the saw is fully rotated upwards, pull the saw out of the cut a few inches and re-engage the pick into the cut and repeat.
- When cutting heavy rebar, slowly “rock” the saw so that you’re always cutting concrete as well as steel. This will help keep the diamonds exposed. Also, expect less chain life when cutting heavy rebar.
- Expect more chain stretch when making nose buried cuts for extended periods of time, as the chain does not have a chance to “throw” the slurry away from the nose of the bar.
- If the saw begins to cut consistently crooked, turn the bar over and use the other side. Dress worn rails with belt sander. Note: The normal life of a guide bar is 2 to 3 diamond chains. Heavy rebar can shorten guide bar life.
- When using a new chain, you can increase the cutting speed by “opening up the diamonds”. Make a few cuts in an abrasive material such as a cinder block.

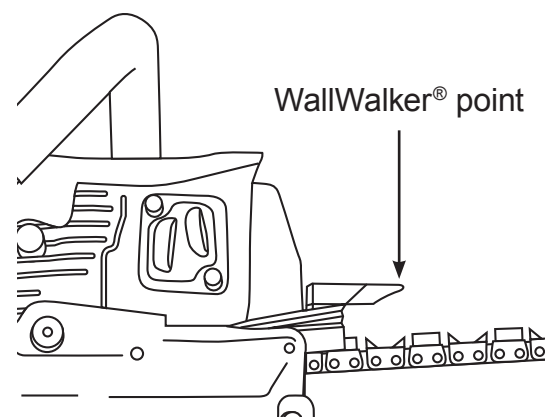

SYSTEM CLEAN-UP

- After cutting, run the saw for at least 15 seconds with the water on to flush slurry and debris from chain, bar and drive sprocket.
- Wash concrete slurry from saw assembly.
- Avoid getting any water in the carburetor or exhaust system. If water enters exhaust port, point the bar tip down and pull the starter handle several times to expel water from muffler.
- Remove bar and chain. Flush out the chain tensioner with high water pressure and lubricate with grease.
- After cleaning the saw, spray the entire saw body, chain, bar, and drive sprocket with lightweight oil. Using lightweight oil on the saw will minimize rust and help reduce slurry build up.

Follow these simple maintenance guidelines
and the 633GC Concrete Cutting Saw will keep running at its very best.

AFTER EACH USE

1. Rinse the saw, guide bar and diamond chain with water.
2. Follow instructions on the Daily Maintenance Label, located on the air filter cover.

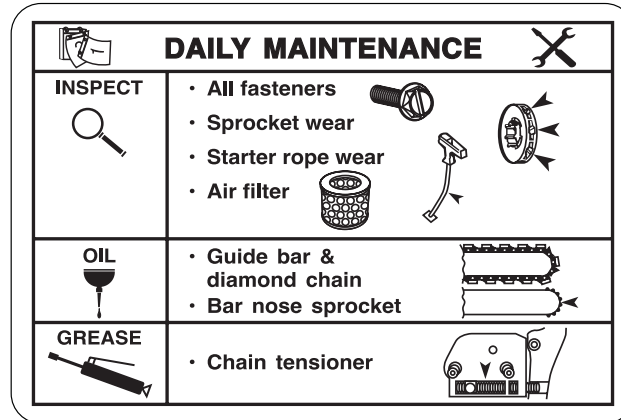

3. Inspect and tighten all fasteners as necessary.
4. Inspect drive sprocket for tooth wear and replace if tooth tips are pointed.
5. Inspect the starter cord. Replace if frayed.
6. Clean air filter. Inspect the air filter for holes. Replace as necessary.
7. Spray saw, guide bar, and chain with lightweight oil.
8. Grease the chain tensioner.

AFTER 10 HOURS OF USE

1. Remove the starter cover and lubricate the starter recoil spring. Clean the flywheel fins and the starter pawls with a wire brush, then grease the starter pawls.
2. Remove the spark plug and clean with a wire brush. Check the electrode gap. The correct gap is 0.020 inches (0.5mm).

AFTER 40 HOURS OF USE

1. Change the spark plug. Adjust the electrode to 0.020 inches (0.5mm).
2. Check the fuel filter located inside the fuel tank. Clean or replace if clogged

AIR FILTER

IMPORTANT

The air filter is made from a nylon micro mesh air filter and an internal spit-back screen. Both must be kept clean for the engine to operate properly. If the saw is not reaching full RPM, most likely one or both of the air filters are dirty.

- The air filter (Figure 1) should be free of holes and white in color.
- Replace air filter when dirty.
- The spit-back screen (Figure 2) should be free of holes and be white in color. Clean with mild solvent or gasoline and dry with high pressure air. If spit-back screen is dirty the saw will not reach full RPM.
- During re-assembly, tighten air filter wing-nut "finger tight" plus an 1/8" of a turn with wrench.

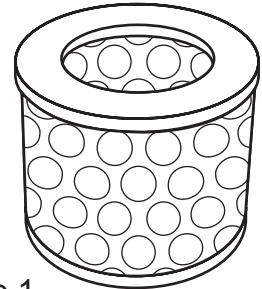

Figure 1



Figure 2

STARTER HOUSING ASSEMBLY

IMPORTANT

It is common for concrete slurry to get inside the starter housing assembly during cutting. This can cause the starter pawls to stick and not engage when the rope is pulled.

- After each usage, thoroughly flush the starter housing assembly with water.
- Oil the recoil spring by spraying lightweight oil into the port (Figure 3).
- Oil the starter pawls by spraying lightweight oil into the starter housing through the vents.
- Check the starter cord for fraying, replace if necessary.

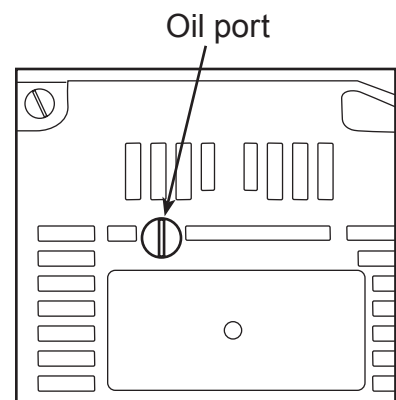

Figure 3

STARTER ROPE REPLACEMENT

- Remove the four screws attaching the starter assembly to the crankcase, and remove the starter cover assembly.
- Remove the three starter pulley cover screws.
- Remove the starter pulley cover.
- Pull the rope out until the notch in the pulley has made at least two full revolutions and is at the rope inlet, then hold the pulley in place (Figure 1).

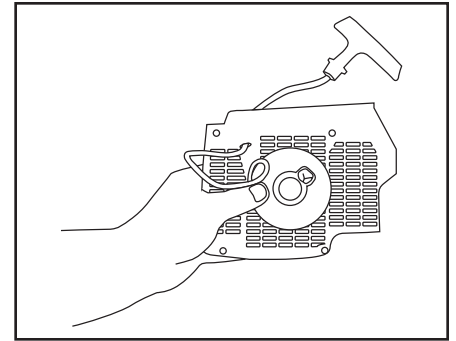

Figure 1

- While holding the pulley in place, lift the rope into the pulley notch and allow the pulley to unwind slowly (counterclockwise) without wrapping the rope (Figure 2). Do this until the recoil spring is completely unwound.
- Undo the screw in the center of the pulley, and remove the pulley.
- Remove the old rope from the pulley. Retain the starter rope washer.
- Pry the starter rope retainer from the starter rope handle, and remove the old rope from the handle.
- Tie a knot in one end of the rope and thread the rope through the:
 - o Starter rope washer, then
 - o Starter rope pulley, then
 - o Starter cover, then
 - o Starter rope handle, then
 - o Starter rope retainer
- Tie a knot to lock the end of the rope in the starter rope retainer.
- Reseat the starter rope retainer in the starter rope handle.
- Replace the pulley in the starter cover. Use blue Loctite #242 on the starter pulley screw.

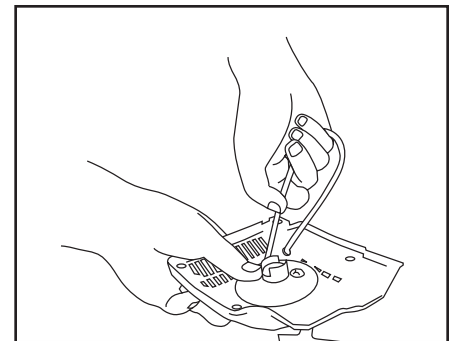

Figure 2

TENSIONING THE RECOIL SPRING

- With the rope fully extended and no tension on the recoil spring, lift the rope into the notch in the pulley and rotate the pulley clockwise 7 wraps (Figure 2), and then allow the spring to retract the rope.
- This should apply the proper amount of tension to the recoil spring.
- If the pulley is over-wrapped, the recoil spring will break on use. To check that the starter pulley is not over-wrapped, pull the cord completely out of the housing, and turn the pulley an additional 1/2 turn clockwise. If the pulley turns another 1/2 turn, it is correctly assembled. If not, release one wrap of rope and check again.

STARTER HOUSING ASSEMBLY

- To reattach the starter housing, first pull the starter cord out, then hold the starter housing against the crankcase (Figure 1). Slowly release the starter cord to enable the pulley to fit between the pawls.
- Insert and tighten the screws. Use blue Loctite® #242.

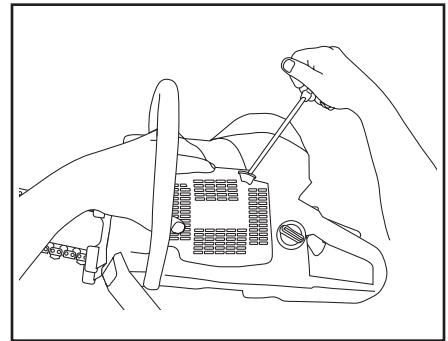

Figure 1

CHAIN TENSIONER

IMPORTANT

The chain tensioner (Figure 2) can become clogged with concrete slurry during cutting. After each use thoroughly flush the chain tensioner with water and apply a liberal amount of grease.

Most Common Causes of Tensioner Damage:

- Side cover nuts are not tight enough. Side cover nuts should be torqued to 20 ft-lbs (27Nm).
- Chain tensioning is attempted without loosening the side cover nuts.
- Concrete debris in tensioner pocket.

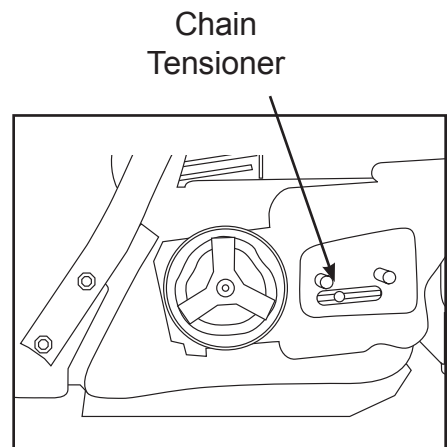

Figure 2

DRIVE SPROCKET

IMPORTANT

The drive sprocket (rim sprocket) is a wear item and should be replaced every 2-3 diamond chains.

IMPORTANT

The needle bearing inside the splined adapter should be greased regularly and should be replaced with each new clutch cup.

A rim sprocket system (Figure 1) consists of a clutch cup w/ splined adapter and a rim sprocket. When the rim sprocket wears out, it is the only part that needs to be replaced. The clutch cup with splined adapter is a wear item that needs replacement after 3 to 5 rim sprockets have been used.

- Inspect the rim sprocket for wear. Replace the rim sprocket if the drive teeth become pointed.
- Check the drive sprocket bearing by spinning clutch cup. Replace the bearing if it is worn out.
- The needle bearing on the drive shaft must be greased regularly, use high quality water-resistant bearing grease.

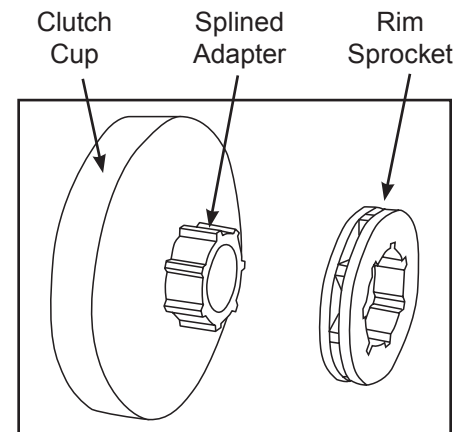

Figure 1

DRIVE SPROCKET REMOVAL

- Remove the side cover, guide bar, diamond chain, and clutch slurry shield.
- Remove the spark plug and insert the piston stop (supplied with each saw) into the spark plug hole. Pull the starter cord slowly until the piston stops. (Figure 2) Use a 19mm wrench to turn the clutch clockwise and remove.
- Slide the clutch cup/drive sprocket assembly off the shaft. Remove the needle bearing and inspect for heavy wear or damage.

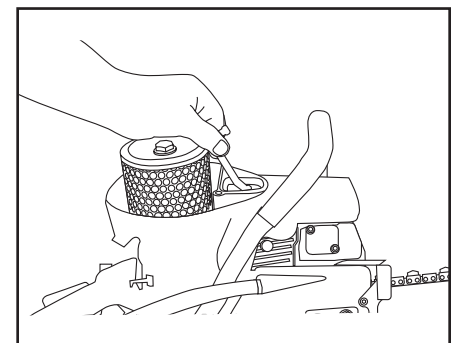

Figure 2

DRIVE SPROCKET INSTALLATION

- Slide the rim sprocket onto the splined adapter, either side out.
- Apply a liberal amount of grease to the needle bearing.
- Place the thin metal washer onto drive shaft. Slide the needle bearing and clutch cup w/rim sprocket onto shaft (Figure 1).
- Install the clutch by turning it counter clockwise on the drive shaft and firmly tighten. Replace the clutch slurry shield. Installation of drive sprocket assembly is now complete.
- The needle bearing on the drive shaft has to be greased regularly (daily). Use high quality water-resistant bearing grease.
- **Bearing Tip:** It is not necessary to remove the clutch cup to grease the bearing. There is a channel that goes directly from the drive shaft to the bearing (Figure 2). Simply inject grease directly into the end of the drive shaft.

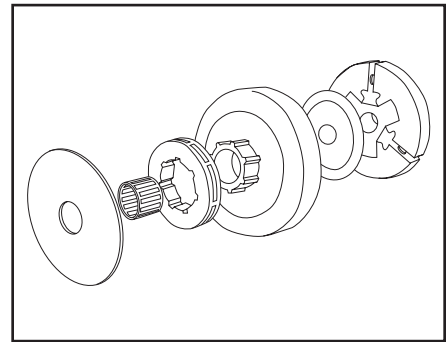

Figure 1

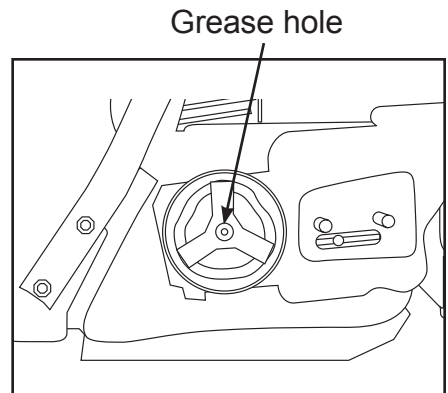

Figure 2

SPARK PLUG

- A worn or fouled spark plug can cause a loss of power, difficulty starting or rough idle (Figure 3).
- If the spark plug is dirty, clean it with a wire brush and check the electrode gap. Readjust if necessary. The correct gap is .020" (0.50mm).
- The spark plug should be replaced after 40 hours of operation or earlier if the electrode is badly corroded.
- Always use the recommended spark plug type. Using the wrong spark plug can severely damage the piston and cylinder (Champion RCJ7Y).

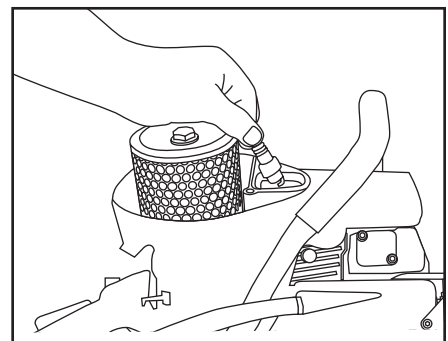
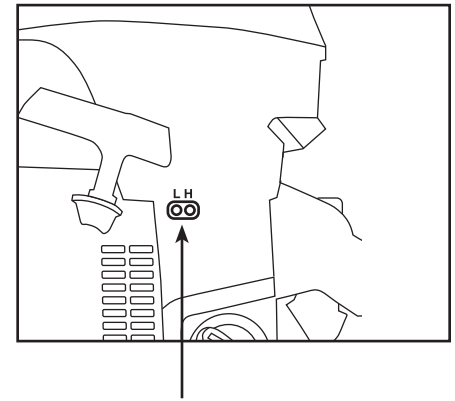

Figure 3

CARBURETOR

- The function of the carburetor is to mix fuel with air. Adjustments other than idle speed should be made by a servicing dealer.
 - **Before adjusting the engine idle speed, make sure the air filter is clean and the engine is warmed up.**
- T – Idle Screw** is adjusted so that the engine idles smoothly but the clutch does not engage.
- **If saw has been running satisfactorily and there is a gradual decrease in power and drop in RPM at full throttle, the filter may have become dirty or saturated with water.**



Carburetor idle screw

GUIDE BARS

- The bar is designed to be used on both sides. If the cut is consistently leading to one side, turn the bar over to expose a new set of rails.
- A table mounted belt or disc sander can be used to square the rails of a worn bar. A badly worn bar can quickly damage an expensive chain. If the chain is touching the bottom of the bar groove, replace the bar.
- Check the guide bar for straightness. Minor adjustments can be made by bending the bar slightly.
- Proper chain tension will extend bar life. See page 9.
- Under some circumstances, especially low water pressure, the sprocket nose can wear out before the guide bar body. Sprocket nose replacement kits may be purchased from an Authorized Dealer (part #70249).
- Spray the chain and bar with lightweight oil for storage.
- Store bar with the sprocket nose up.
- Periodically clean the water ports inside the groove of the bar using a small diameter piece of wire. Water port cleaners are available from an Authorized Dealer.
- The bar is solely a guide track for the chain. Never use the bar to lift, twist or pry concrete material.

After Every Use

1. Rinse saw, bar & chain with water.
2. Check for loose fasteners. Tighten as necessary.
3. Inspect, flush and grease the chain tensioner.
4. Inspect drive sprocket for wear. Replace sprocket if groove cuts through the top of the tooth.
5. Check drive sprocket bearing for wear by spinning clutch cup. Replace if worn out.
6. Grease drive sprocket bearing. Inject grease into the end of the drive shaft. Spin clutch cup while greasing.
7. Check the starter cord for wear or damage. Replace as necessary.
8. Lube starter recoil spring. Spray lightweight oil into lube hole. Also, spray lightweight oil into the air intake slots on the starter housing to keep starter pawls from sticking.
9. Inspect air filter and spit-back screen. Replace filter if dirty.
10. Spit-back screen should be white with no oil build-up. Rinse in gas or solvent to clean.
11. Spray saw, bar and chain with lightweight oil.

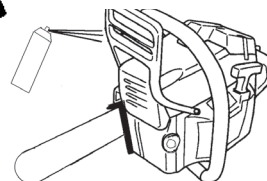
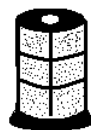
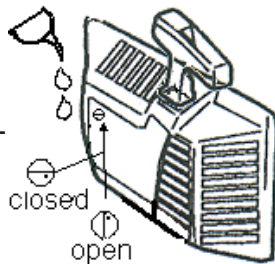
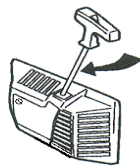
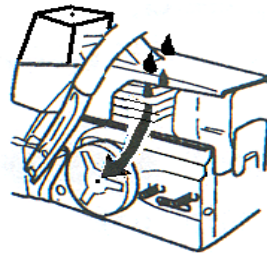
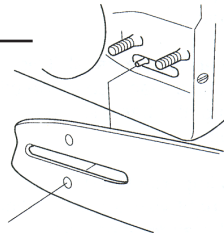
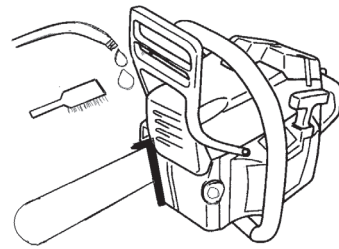

After 10 hours

1. Remove the starter cover and lubricate the starter recoil spring. Clean the fins and the starter pawls on the flywheel with a wire brush, then grease starter pawls.
2. Remove & clean the spark plug. Check the electrode gap. The correct gap is .020 inch (0.5mm).
3. Inspect air filter, replace if necessary.
4. Clean the spit-back screen (inside the air filter) with gas or solvent.

After 40 hours

1. Change spark plug. Adjust electrode gap to .020 inch (0.5mm).
2. Check fuel filter located inside the fuel tank. Clean or replace if clogged.

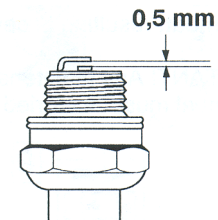

TROUBLESHOOTING

- **SAW WON'T REACH FULL RPM** – Air filter or pre filter may be dirty.
- **SLOW CHAIN SPEED** – Chain tension too tight. Chain should always be able to be pulled around the bar by hand. It is normal for the chain drive links to hang below the bar.
- **POOR CUTTING SPEED** – Diamonds may be “glazed over”. Make a few cuts in an abrasive material such as a cinder block to expose the diamonds.
- **PREMATURE CHAIN STRETCH** – Not enough water pressure. The minimum water pressure required is 20 psi (1.4 bar). **Insufficient water supply may result in excessive wear to the diamond chain, which can lead to loss of strength and diamond chain breakage.**
- **CHAIN TENSIONER BREAKAGE** – Side cover nuts are not tight enough.
Torque to 20 ft-lbs (27Nm).
- **WATER NOT FLOWING** – Water hose is kinked or supply is not turned on.
- **WON'T START** – Turn ignition switch on or possible defective spark plug.
- **WON'T START** – Low compression, less than 120 psi (8 bar). Possible incorrect fuel mixture.
Reference: new = 150 to 180 psi (10 to 12 bar)
used = 140 to 160 psi (9 to 11 bar)
- **DIFFICULT TO START** – Possible flooded engine. Turn ignition switch on, push choke in, hold throttle on full with foot and pull starter cord until engine starts.
- **DIFFICULT TO START** – Possible fouled spark plug. Remove spark plug, clean with wire brush and re-gap.
- **CHAIN BREAKAGE** – Chain installed backwards. Bumpers should lead segments into the cut.
- **CHAIN BREAKAGE** – Not enough feed pressure while cutting. Avoid letting the saw bounce and chatter.

Further questions?

**Call 1-800-321-1240 or
visit our website at icsbestway.com**

APPROXIMATE CUTTING RATES

Material	Cutting Rate
Hard aggregate & Steel	15-25 sq-in/min (90-160 sq-cm/min)
Medium aggregates	20-30 sq-in/min (160-190 sq-cm/min)
Masonry, Soft aggregates	30-50 sq-in/min (190-320 sq-cm/min)

INCH-FOOT DEFINITION

An in-ft is a measure of how much material is to be cut.

An in-ft is defined as: depth in inches times length in feet.

Note: 129 in-ft = 1m²

Example: How many in-ft are in this doorway?

1. Determine the depth of the cut in inches.
For this example, 8 inches.
2. Determine the length of the cut in feet.
 $3+7+3+7=20$ feet
3. Multiply the two numbers
 $8 \text{ in} \times 20 \text{ ft} = 160 \text{ in-ft}$

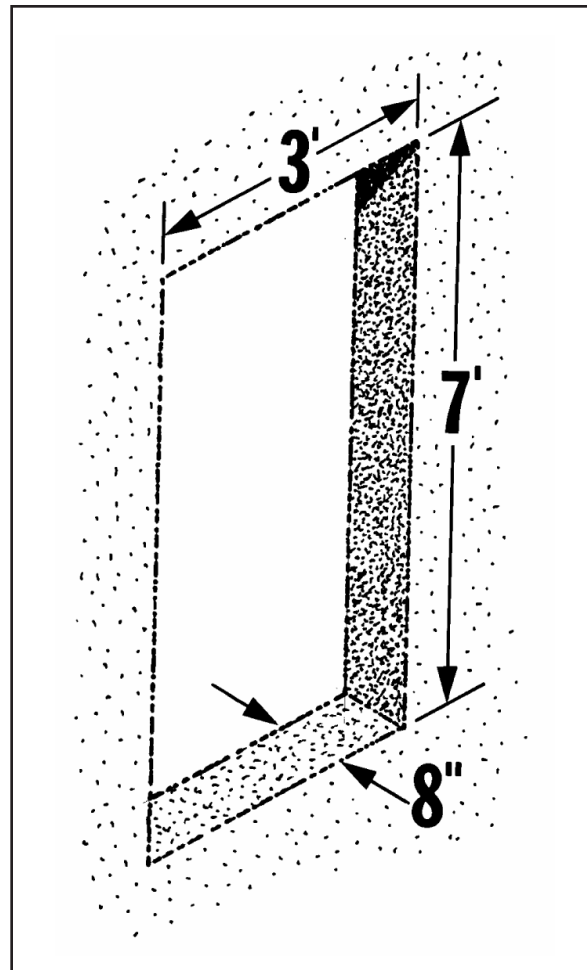

633GC OPERATOR'S MANUAL

**ICS, Blount Inc.
4909 SE International Way
Portland, OR 97222
Tel 800-321-1240 Fax 503-653-4393
icsbestway.com**